

PNT 290

Here is the work platform
you were **looking for.**

ISOLI
SKYWORK



29m

PNT 290 is an articulated work platform that can reach 29 meters in height, especially suitable for maintenance, construction and industrial works. Technology and engineering solutions meeting the main work-at-height requirements in an easy and safe way. Here is the work platform you were looking for.

Innovation

Despite its compact size, PNT 290 delivers high performance. The removable work platform system allows further reducing the on-road footprint. This dynamic and compact work platform can reach 29 meters in height while maintaining a **constant and guaranteed 250-kg load capacity**, and is simple and efficient to use in any application.

Safety

PNT 290 offers **top-level safety systems** that ensure easy and secure operations. The **aluminum work platform with elevated front attachment** makes working at height easier and safer. Its **unique outrigging within the vehicle envelope and the use of hi-tech materials** ensure high performance, superb lateral reach and uncompromising safety.

Ease of use

Its **small footprint and easy-to-use electric controls** make PNT 290 the ideal choice to meet the main work-at-height requirements, even for inexperienced users. Moreover, Isoli PNT 290 is also equipped with a **convenient work platform removal system** that reduces its footprint when on the move, and allows it to be used for lifting operations when replacing the platform with the supplied hook.

**ISOLI PNT 290,
working at height
was never so easy**

**DIMENSIONI / OVERALL DIMENSION /
GESAMTABMESSUNGEN / DIMENSIONS [mm]**

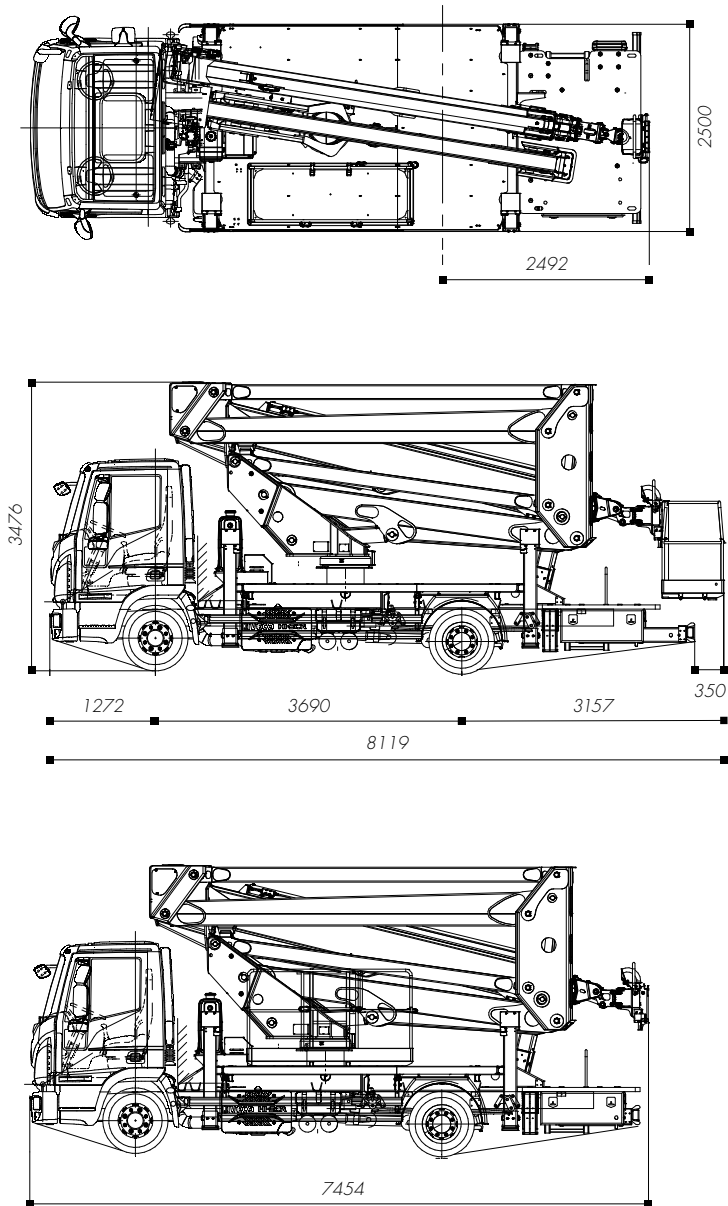

**DIAGRAMMA DI LAVORO / WORKING DIAGRAM /
ARBEITSDIAGRAMM / SCHÉMA DE TRAVAIL [m]**

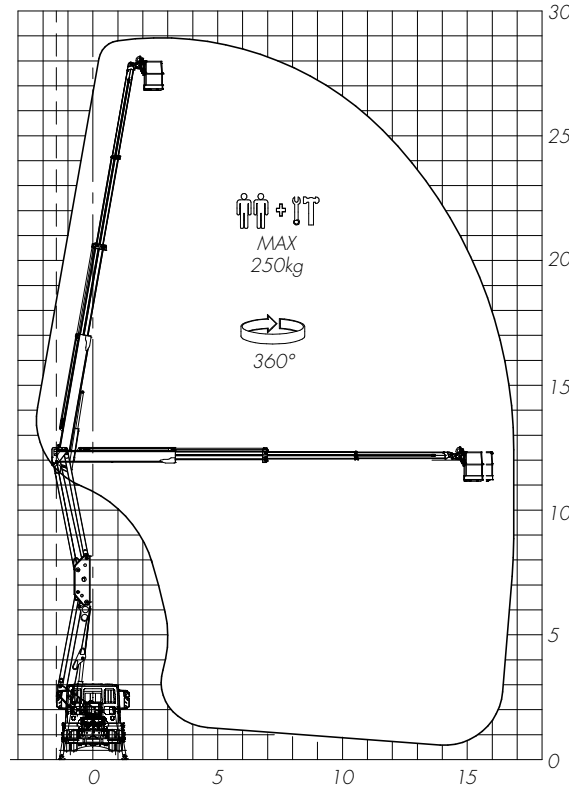

**CARATTERISTICHE TECNICHE / TECHNICAL FEATURES /
TECHNISCHE EIGENSCHAFTEN / DETAILS TECHNIQUES**

	Altezza max. di lavoro Max. working height Max. Arbeitshöhe Hauteur travail	29 m
	Sbraccio max. di lavoro Max. working boom extension Max. Reichweite Portée à hauteur maximale	17 m
	Portata Capacity Traglast Charge utile	250 Kg
	N. operatori N. operators Anzahl Personen N. opérateurs	2
	Altezza piano calpestio Walk-on surface height Korbdenhöhe Hauteur plancher	27 m
	Rotazione sovrastruttura Upperstructure rotation Drehung Oberwagen Rotation tourelle	400°
	Cesta Basket Arbeitskorb Panier	2200x750x1.100 mm
	Rotazione cestello Basket rotation Korbrotation Rotation panier	+/- 90°
	Comandi Controls Steuerungen Commandes	Elettroidraulici Electro-hydraulic Elektrohydraulisch Électrohydrauliques
	Stabilizzatori Outriggers Abstützungen Stabilisation	Verticale H-H sagoma Vertical stabilisation HH in folded position Vertikale Stabilisierung HH in gefalteter Position Verticale HH dans le gabarit





DA SEMPRE IN PRIMA LINEA

ISOLI S.P.A.

PIATTAFORME AEREE - CARRI SOCCORSO - ALLESTIMENTI SPECIALI/
AERIAL PLATFORMS - BREAKDOWN TRUCKS - SPECIAL OUTFITTINGS

Via Boschi 44 - 35014 Fontaniva (PD) Italy / P.I. 00202970281
Tel +39 049 9438611 - isoli@isoli.com - www.isoli.com