



## Exceptional productivity

- Telescopic jib provides 6 m (19 ft 8 in) additional outreach which is extremely practical for accessing work areas and for getting around obstacles
- 4 simultaneous and proportional movements
- Double load capacity: 350 kg / 770 lbs (3 persons) or 230 kg / 500 lbs (2 persons)
- Tailswing of 72 cm for more compactness

## Optimal rough terrain driving features

- 4 wheel drive
- Front oscillating axle
- Differential wheel lock
- 52 cm ground clearance





# H28 TJ+



ROUGH TERRAIN TELESCOPIC BOOMS

230 kg / 2x

350 kg / 3x

## TECHNICAL DATA

### H28 TJ+

Working height	27.5 m
Platform height	25.5 m
Horizontal outreach	22.6 m
Lift capacity	230 - 350 kg
<b>F</b> x <b>G</b> Platform size	1.8 x 0.8 m
<b>A</b> Length - stowed	12.35 m
<b>H</b> Length - storage	9.45 m
<b>B</b> Width	2.49 m
Width - with extended axles	N/A
<b>C</b> Height - stowed	2.95 m
<b>J</b> Height - storage	2.95 m
Vertical jib rotation	133° (+63°/-70°)
Platform rotation	180° (+90°/-90°)
Boom rotation angle	75°
Turntable rotation	360° continuous
Tailswing	72 cm
<b>D</b> Wheelbase	3 m
<b>E</b> Ground clearance	52 cm
Tilt	4°
Drive speed	0.5 - 5 km/h
Gradeability	40 %
Turning radius - outside	7.45 m
Tires - foam-filled	385-45-28
Engine	55 kW - 75 hp
Weight	17300 kg

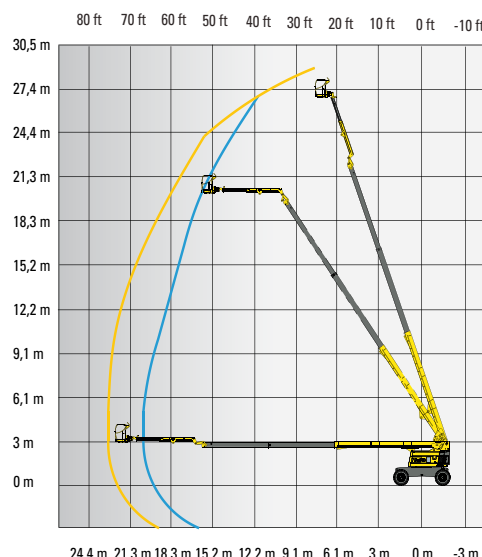

## STANDARD EQUIPMENT

- 4 wheel drive, 2 wheel steer
- Front oscillating axle increasing stability on uneven ground
- Differential wheel lock increasing rough terrain capacity
- Proportional controls enhancing comfort and safety
- 4 simultaneous movements for highest productivity
- Telescopic jib with octagonal cross section for additional versatility and optimal rigidity
- Dual load capacity : 230 kg (2 persons) / 350 kg (3 persons)
- Sound and light alarm for tilt and load
- Electric pump system and emergency descent
- 12 V battery / electrical control system
- Swing out engine tray for ease of maintenance
- Safe to use in winds up to 45km/h / 28mph
- Hydrostatic transmission
- Low fuel level indicator (upper control box)
- Engine pre-heater with light indicator
- Hourmeter
- Tow hooks and lift hooks

## OPTIONS AND ACCESSORIES

- On-board 3.3kW generator
- Cold weather kit
- Power to platform (Female plug in the basket 110V/220V)
- Alarm package (motion alarm and travel alarm)
- Travel alarm
- Rotating beacon
- 15W flashing light
- Air line to platform
- 55W platform working light
- Hydraulic oil cooler
- Hydraulic oil in tank and circuit for warm countries
- Biodegradable hydraulic oil
- Upper control box protection cover (transparent plastic and fixed place)
- 30 mA circuit-breaker
- Large platform 2.44 x 0.8m

