

Scroll Tankmount/Basemount Air Compressors

Please read and save these instructions. Read carefully before attempting to assemble, install, operate or maintain the product described. Protect yourself and others by observing all safety information. Failure to comply with instructions could result in personal injury and/or property damage! Retain instructions for future reference.

Description

GENERAL

The Powerex Oilless Rotary Scroll Air Compressor has advanced scroll compressor technology through the development of a completely oilless unit. The Powerex Scroll Compressor offers a dynamically balanced air end which insures vibration-free operation. The rotary design permits a continuous 100% duty cycle. No oil separation, oil filtration, or inlet valves are required on the Powerex Scroll unit.

COMPRESSION CYCLE

The Powerex oilless rotary scroll air compressor is based on the theory of scroll compression. A scroll is a free standing, intricate spiral bounded on one side by a solid, flat plane or base. A scroll set, the basic compression element of a scroll compressor, is made up of two identical spirals which form right and left hand parts. One of these scroll components is indexed or phased 180° with respect to the other so the scrolls can mesh. Crescent-shaped gas pockets are formed and bounded by the spirals and the base plate of both scrolls. As the moving scroll is orbited around the fixed scroll, the pockets formed by the meshed scrolls follow the spiral toward the center and diminish in size. The moving scroll is prevented from rotating during this process so the 180° phase relationship of the scrolls is maintained. The compressor's inlet is at the outer boundary of the scrolls. The compressed gas is discharged through the outlet at the center of the fixed scroll so no valves are needed.

TIP SEAL

The tip seal on the scroll compressor is self-lubricated and allows the unit to operate efficiently without oil and expensive filtration. On standard pressure units, the tip seal should be replaced every 10,000 hours of operation. On high pressure units, the tip seal should be replaced every 5,000 hours of operation.

BEARINGS

The bearings on the scroll compressor are regreaseable to allow extended compressor life. For standard pressure units, service should be performed every 10,000 hours of operation. For high pressure units, service should be performed every 5,000 hours of operation.

DRY TYPE INLET FILTER (P/N ST073925AV)

Order element P/N ST073921AV for both the 3 HP and 5HP units. Change every 2,500 hours or more often in dirty locations.

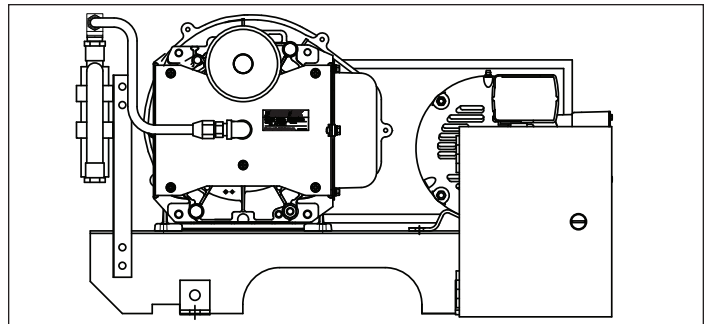

Figure 1 - SBS Scroll Basemount Simplex

Specifications

Product	STS, STD, SBS Scroll or STSH, STDH, SBSH High Pressure Scroll Tankmount/ Basemount Air Compressors
Performance Specifications	See Page 2
California Ordinance 462 (L) (2)	Tankmount units meet the requirements of this ordinance
Compression Cycle	Scroll
Control Panel	UL508A Listed (panels are optional)
Drive	2 - 3V Belts
Lubrication	Grease filled bearings
Motor Overload Protection	IEC Motor overload relay (optional)
Operating Temperature	34° F - 104° F (1° C thru 40° C) at inlet
Operating Voltages	1Ø 280-230 Volts, 60 Hz 3Ø 208-320/460 Volts, 60 Hz
Outlet Air Connections	1/2 inch Basemount 3/4 inch NPT Tankmount
Overpressure Protection	ASME safety valve factory set and sealed
Standard Pressure Settings	Simplex: 95-115 psi Duplex: 90-110 psi; 95-115 psi
High Pressure Settings	Simplex: 115-145 psi Duplex: 110-140 psi; 115-145 psi
Tank Isolation	Standard tank mount units
Tank Size (Tankmount Units)	Simplex Units: 30 and 60 gallon ASME Rated 200 psig Duplex Units: 80 and 120 gallon ASME Rated 200 psig

Scroll Air Compressors Tankmount/Basemount

Performance Specifications

	Model	HP	Phase	SCFM @ 100 psig	SCFM @ 145 psig	Voltage	Gallon Tank
Scroll Basemount Simplex - Model SBS	SBS0307	3	3	8.8	7.1	208-230/460 115/230	Basemount
	SBS1307	3	1	8.8	7.1		Basemount
	SBS0507	5	3	15.2	12.5	208-230/460 208-230	Basemount
	SBS1517	5	1	15.2	12.5		Basemount
Scroll Tankmount Simplex - Model STS	STS030	3	3	8.8	7.1	208-230/460 115/230	30/60
	STS130	3	1	8.8	7.1		30/60
	STS050	5	3	15.2	12.5	208-230/460 208-230	30/60
	STS151	5	1	15.2	12.5		30/60
Scroll Tankmount Duplex - Model STD	STD030	3 (2)	3	17.6	14.2	208-230/460 115/230	80
	STD130	3 (2)	1	17.6	14.2		80
	STD050	5 (2)	3	30.4	25.0	208-230/460 208-230	80/120
	STD151	5 (2)	1	30.4	25.0		80/120

NOTE: All high pressure models have an "H" at the end of the model identification. These units are measured at 145 psig.

NOTE: For system electrical information (including motor FLA ratings), see the wiring diagram shipped with the unit.

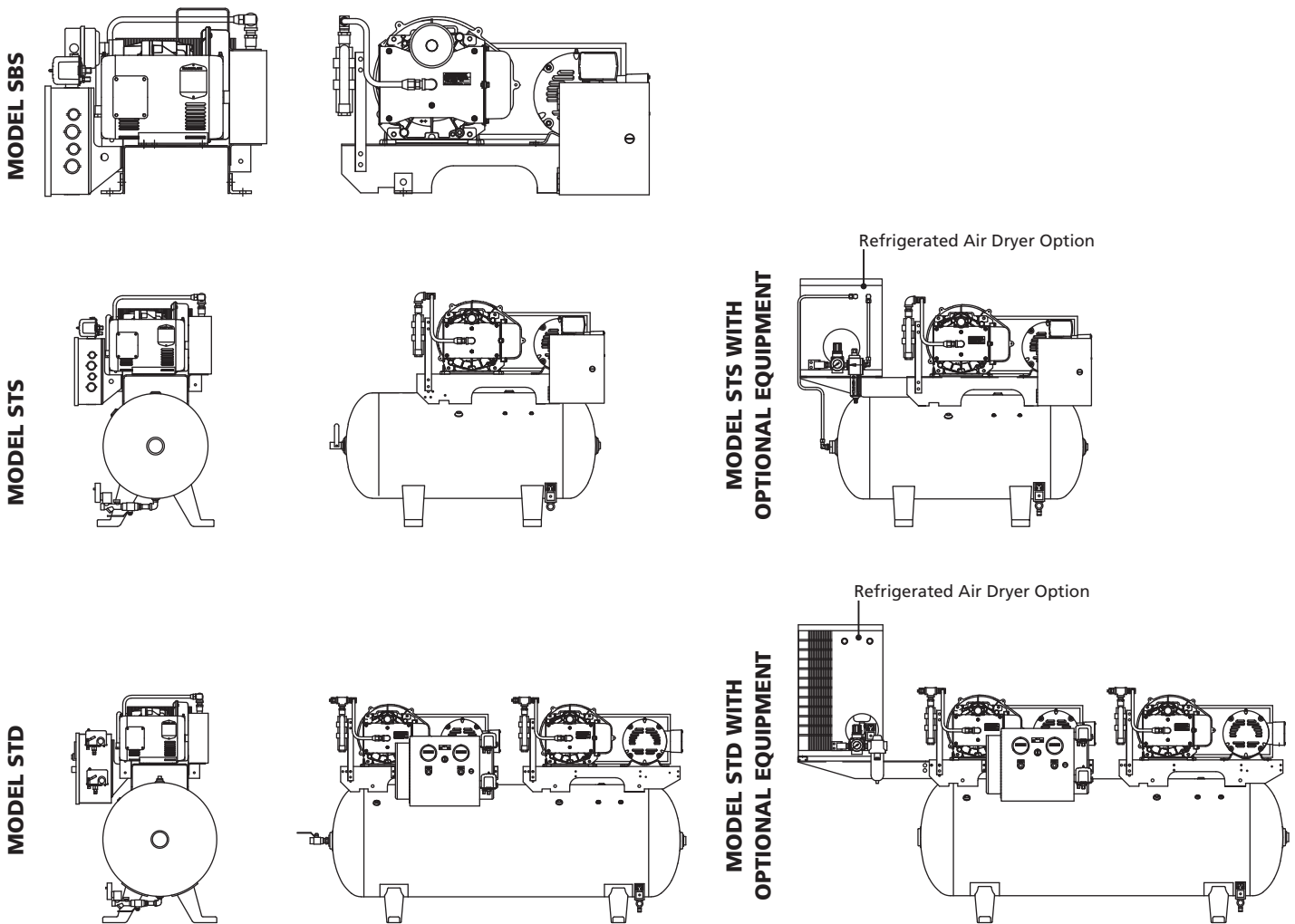

Figure 2 - Standard model configuration and optional equipment

HOURMETER

The hourmeter on the scroll compressor indicates the actual number of hours the unit has been in operation. The hourmeter is also used to determine maintenance and service timing. **An hourmeter must be installed with every Scroll compressor.**

CONDENSATE DRAIN VALVE

A condensate drain valve must be installed on every tank to allow removal of the liquid which will collect during compressor operation.

NOTICE

Drain liquid from tank daily.

Safety Guidelines

This manual contains information that is very important to know and understand. This information is provided for SAFETY and to PREVENT EQUIPMENT PROBLEMS. To help recognize this information, observe the following symbols.

▲ DANGER *Danger indicates an imminently hazardous situation which, if not avoided, WILL result in death or serious injury.*

NOTICE

Notice indicates important information, that if not followed, may cause damage to equipment.

NOTE: Information that requires special attention.

▲ DANGER

Breathable Air Warning

This compressor/pump is not equipped and should not be used "as is" to supply breathing quality air. For any application of air for human consumption, you must fit the air compressor/pump with suitable in-line safety and alarm equipment. This additional equipment is necessary to properly filter and purify the air to meet minimal specifications for Grade D breathing as described in Compressed Gas Association Commodity Specification G 7.1 - 1966, OSHA 29 CFR 1910. 134, and/or Canadian Standards Associations (CSA).

DISCLAIMER OF WARRANTIES

IN THE EVENT THE COMPRESSOR IS USED FOR THE PURPOSE OF BREATHING AIR APPLICATION AND PROPER IN-LINE SAFETY AND ALARM EQUIPMENT IS NOT SIMULTANEOUSLY USED, EXISTING WARRANTIES SHALL BE VOIDED, AND POWEREX DISCLAIMS ANY LIABILITY WHATSOEVER FOR ANY LOSS, PERSONAL INJURY OR DAMAGE.

Installation

RECEIVING THE UNIT

Immediately upon receipt of the scroll compressor, the unit should be inspected for any damage which may have occurred in shipment. Any shipping damage must be immediately filed with the freight carrier.

The compressor nameplate should be checked to see if the unit is the correct model and voltage as ordered.

APPLICATION

When the scroll compressor is to be used in applications other than the compressing of atmospheric air, please contact a Powerex representative for engineering and warranty information at 1-888-769-7979.

INSTALLATION SITE

1. The scroll compressor must be located in a clean, well lit and well ventilated area.
2. The area should be free of excessive dust, toxic or flammable gases, moisture, water and direct sunlight.
3. Never install the compressor where the ambient temperature is higher than 104° F or where humidity is high.

MINIMUM CLEARANCES

Above	24 inches
Drive belt side	12 inches
Other sides	20 inches

4. Clearance must allow for safe, effective inspection and maintenance.
5. If necessary, use metal shims or leveling pads to level the compressor tank or basemount unit. Never use wood to shim the unit.

VENTILATION

1. If the scroll compressor is located in a totally enclosed room, an exhaust fan with access to outside air must be installed.
2. Never restrict the cooling fan exhaust air.
3. Never locate the compressor where hot exhaust air from other heat generating units may be pulled into the unit.

WIRING

Refer to the general product manual. All electrical hook-ups must be performed by a qualified electrician. Installations must be in accordance with local and national electrical codes.

Use solderless terminals to connect the electric power source.

Installation (Continued)

PIPING

General Guidelines

Refer to the general product manual.

1. Make sure the piping is lined up without being strained or twisted when assembling the piping for the compressor.
2. Appropriate expansion loops or bends should be installed at the compressor to avoid stresses caused by changes in hot and cold conditions.
3. Piping supports should be anchored separately from the compressor to reduce noise and vibration.
4. Never use any piping smaller than the compressor outlet connection.
5. Use flexible hose to connect the outlet of the compressor to the piping so that the vibration of the compressor does not transfer to the piping.

Remote Intake Piping

Powerex Compressor Systems with pipe thread connectors on the intake filters are intended for installation with remote air intake. Piping for the remote intake system must be installed at the final operating site.

Under some conditions, the intake piping may facilitate the condensation of humidity in the intake air stream into liquid water.

NOTICE

The intake filters supplied by Powerex will not stop ingestion of liquid water by the pumps. Liquid water going into the pumps will damage the pumps and void the warranty.

Always install drip legs with sufficient capacity to capture liquid water in the intake piping before the air filters. Drip legs must be sized with low enough air velocity to make sure they are effective at capturing liquid water in the intake air and must be maintained (drained) at frequent intervals to make sure they remain effective.

SAFETY VALVES

Tank mounted compressors are shipped from the factory with safety valves installed in the tank. The flow capacity of the safety valve is equal to or greater than the capacity of the compressor.

1. The pressure setting of the safety valve must be no higher than the maximum working pressure of the tank.
2. Safety valves should be placed ahead of any possible blockage point in the system, i.e. shutoff valve.
3. Avoid connecting the safety valve with any tubing or piping.
4. Manually operate the safety valve every six months to avoid sticking or freezing.

Operation

BEFORE START UP

1. Make sure all safety warnings, labels and instructions have been read and understood before continuing.
2. Remove any shipping materials, brackets, etc.
3. Confirm that the electric power source and ground have been firmly connected.
4. Be sure all pressure connections are tight.
5. Check to be certain all safety relief valves, etc., are correctly installed.
6. Check that all fuses, circuit breakers, etc., are the proper size.
7. Make sure the inlet filter is properly installed.
8. Confirm that the drain valve is closed.

START-UP AND OPERATION

1. Follow all the procedures under "Before start-up" before attempting operation of the compressor.
2. Switch the electric source breaker on.
3. Open the tank discharge valve completely.
4. Check that the compressor operates without excessive vibration, unusual noises or leaks.
5. Close the discharge valve completely.
6. If the pressure does not rise on a three phase unit, turn the unit off. Have a qualified electrician switch the breaker OFF and exchange the L1 and L2 connections (two out of three phases of electric source) inside the magnetic starter enclosure.
7. Check the discharge pressure. Also make sure the air pressure rises to the designated pressure setting by checking the discharge pressure gauge.
8. Check the operation of the pressure switch by opening the tank outlet valve and confirming the compressor starts as pressure drops.

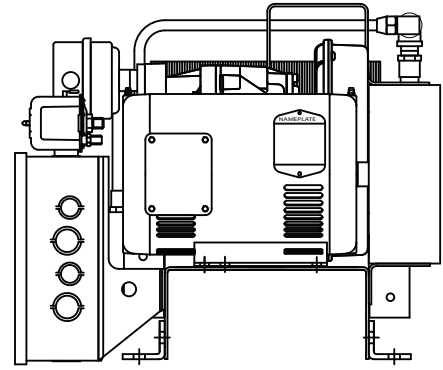
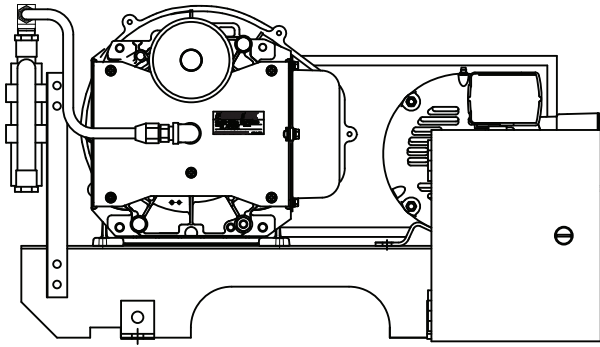

Figure 3 - SBS and SBSH Scroll Basemount Simplex

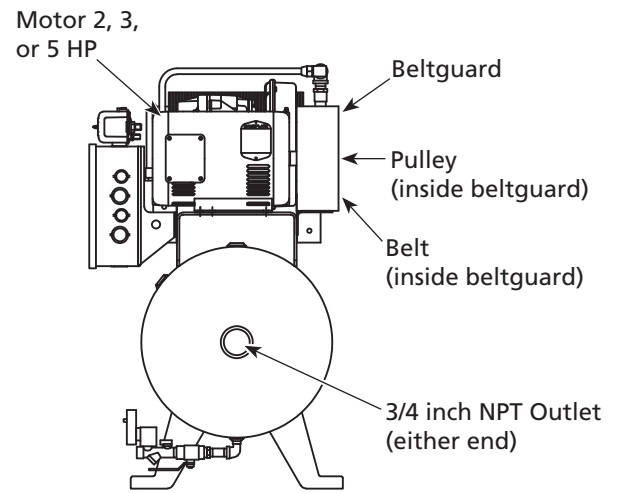
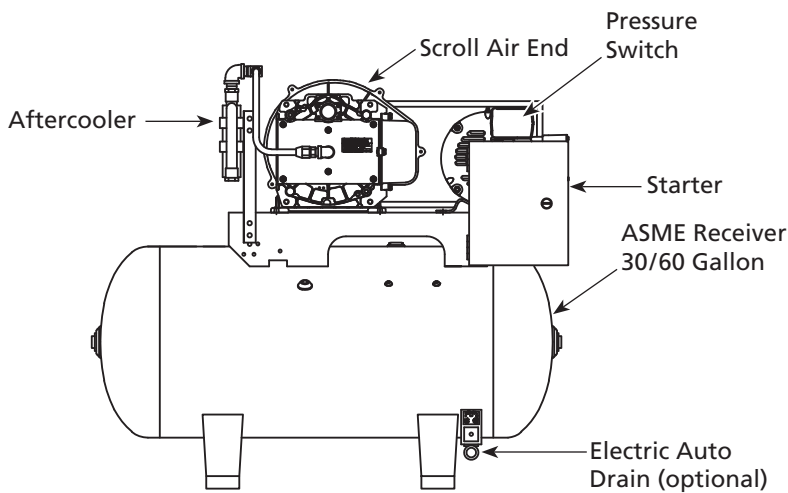

Figure 4 - STS and STSH Scroll Tankmount

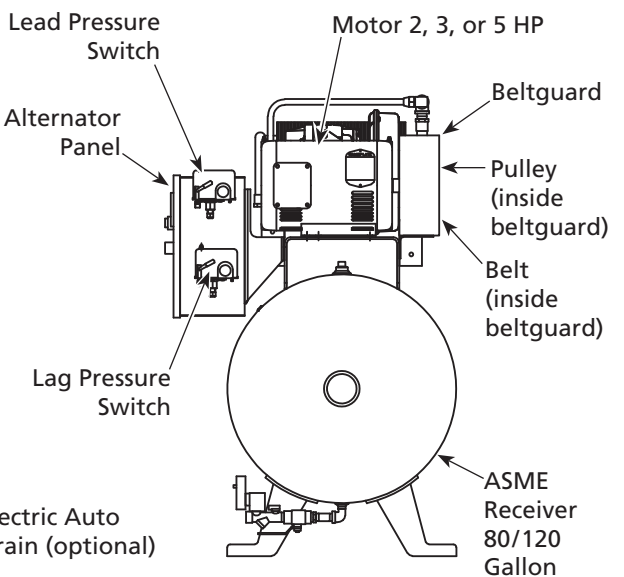
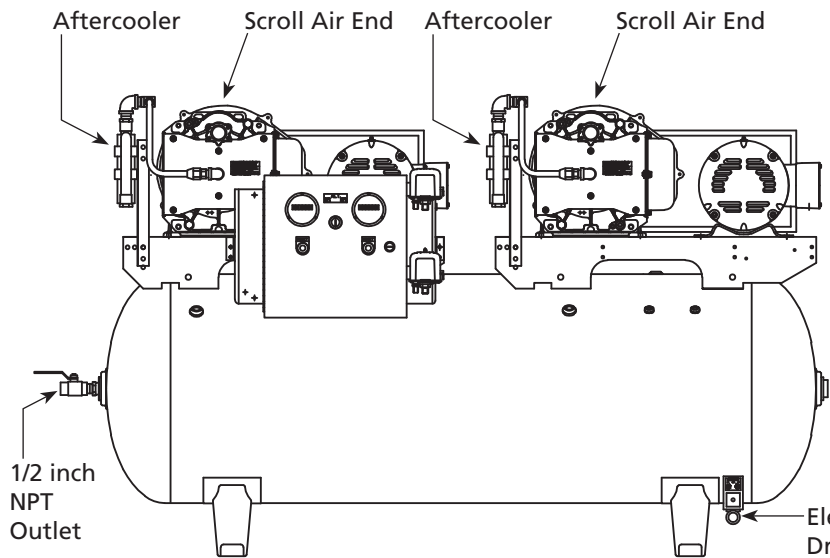

Figure 5 - STD and STDH Scroll Tankmount Duplex

Scroll Air Compressors Tankmount/Basemount

Maintenance

Item	Action needed	Operating Hours							Remarks
		500	2500	5000	10,000	15,000	20,000	30,000	
Pump	Replace							▲	
Tank	Drain moisture	Daily							
Inlet air filter	Inspect, Replace	●	▲	(Every 2,500 hrs or less)					Element Part # ST073921AV
Blower fan	Clean			●	●	●	●		
Fan duct	Clean			●	●	●	●		
Compressor fins	Clean		●	(Every 2,500 hrs or less)					
Bearings	Grease				▲		▲		Service Center Only
Bearings ★	Grease			▲	▲	▲	▲		Service Center Only
Tip seal	Replace				▲		▲	▲	Every 10,000 hours
Tip seal ★	Replace			▲	▲	▲	▲		Every 5,000 hours
Heat insulation pipe	Replace				▲		▲	▲	Every 10,000 hours
Heat insulation pipe ★	Replace			▲	▲	▲	▲	▲	Every 5,000 hours
V-belt	Inspect, Replace	* Note 3	●	▲	▲	▲	▲		
Pressure switch	Confirm operation				●		●		
Magnetic starter	Inspect				●		●		Replace if contact points deteriorated
Safety valve	Confirm operation		●	(Every 2,500 hrs or every 6 months, whichever comes first)					
Pressure gauge	Inspect		●	(Every 2,500 hrs or less)					

- Inspect
- ▲ Replace
- ★ Maintenance requirements for high pressure units.

- Notes:**
1. Inspect and perform maintenance periodically according to maintenance schedule.
 2. The maintenance schedule relates to the normal operating conditions. If the circumstances and load condition are adverse, shorten the cycle time and do maintenance accordingly.
 3. * The tension of the V-belt should be adjusted during the initial stage and inspected every 2,500 hours afterwards. Proper belt tension for 3 HP units is 7 lbs/0.19" deflection; for 5 HP units, 7 lbs/0.19" deflection.
 4. See Compressor Pump Manuals for replacement or service procedures.

Electrical Wiring Diagram - Simplex

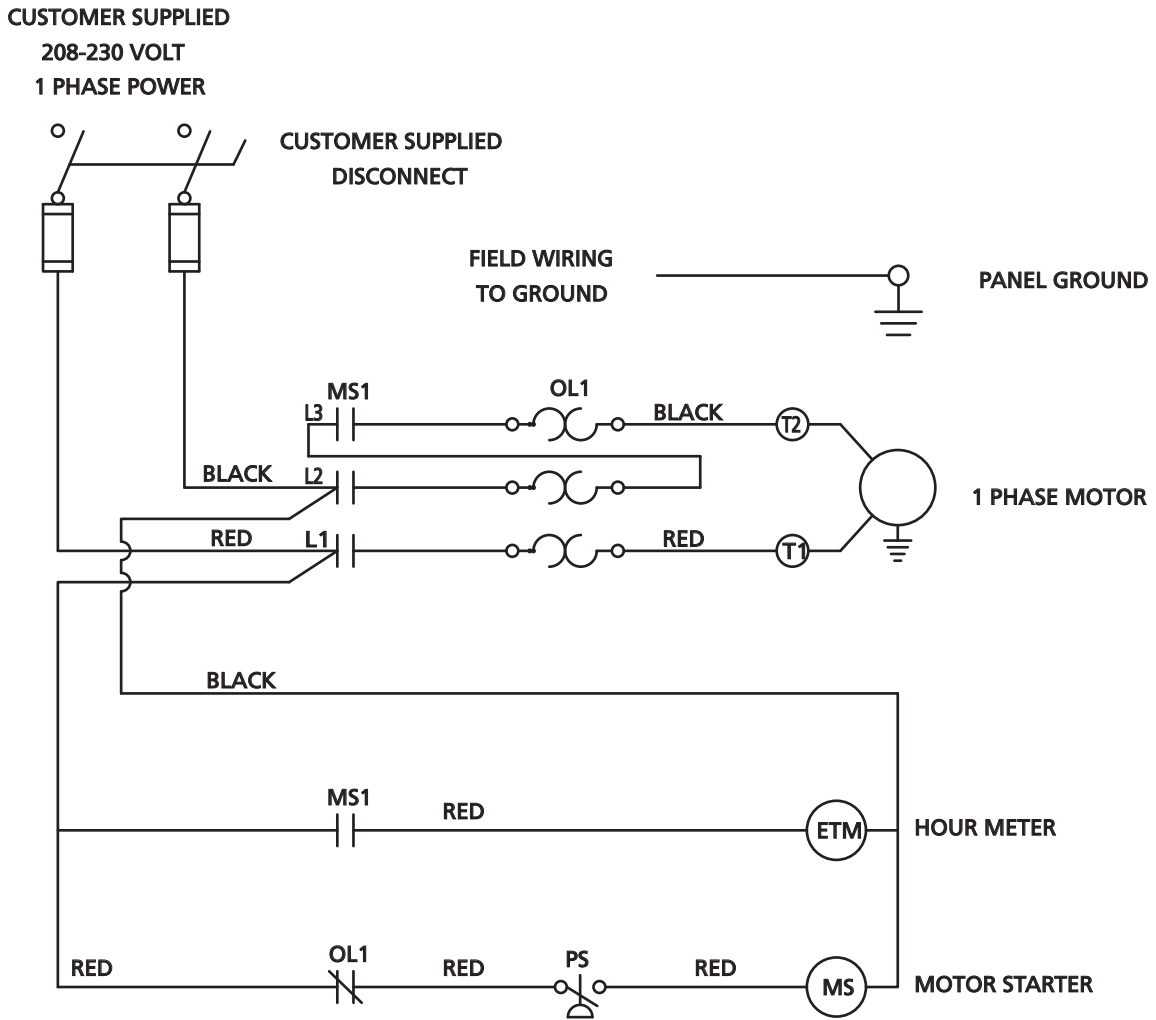

TABLE 1B

PANEL DATA 1Ø - 50/60 Hz		(B) BRANCH CIRCUIT PROTECTION - PROVIDED BY INSTALLER	
(A) MOTOR SIZE EACH (HP)	(A) POWER (1/PH)	(A) MOTOR LOAD EACH (FLA)	(A) PANEL LOAD TOTAL (FLA)
1	208V/1Ø	8.8	11
1.5	208V/1Ø	11	13
2	208V/1Ø	13.2	15
3	208V/1Ø	18.7	21
5	208V/1Ø	30.8	33
1	230V/1Ø	8	10
1.5	230V/1Ø	10	12
2	230V/1Ø	12	14
3	230V/1Ø	17	19
5	230V/1Ø	28	30
1	115V/1Ø	16	18
1.5	115V/1Ø	20	22
2	115V/1Ø	24	26
3	115V/1Ø	34	36
5	115V/1Ø	56	58

NOTE- VALUES ARE BASED ON NEC 2005 SEC 430.
ADJUST OVERCURRENT PROTECTION DEVICE TO ACTUAL
MOTOR NAMEPLATE FLA VALUE

* Main disconnect and branch circuit protection to be installed by a qualified electrician in accordance with national and local codes

Figure 6 - 3-5 HP Basemount/Simplex Single-Phase 208-230 Volts

Electrical Wiring Diagram - Simplex

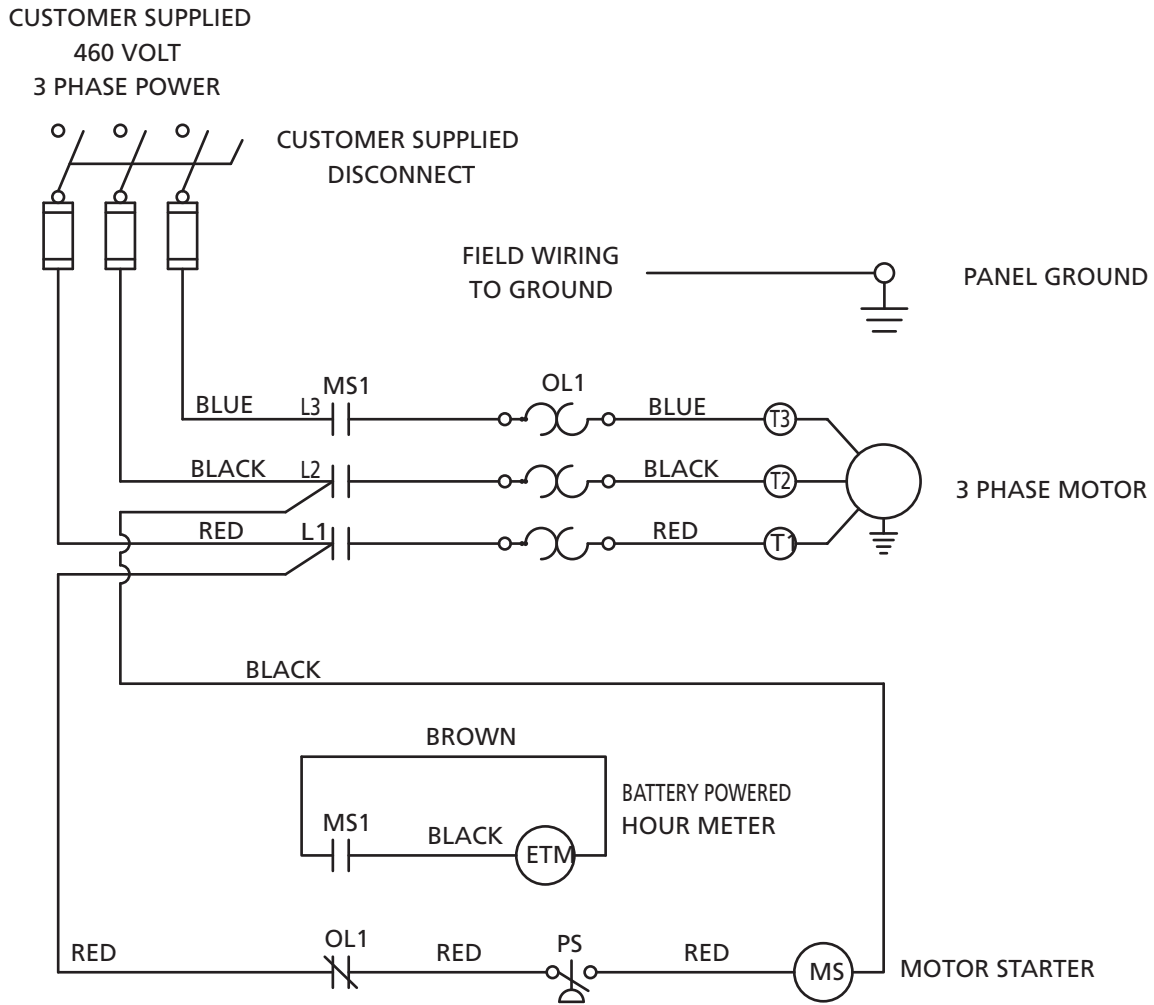

TABLE 1A

PANEL DATA 3Ø - 50/60 Hz		(B) BRANCH CIRCUIT PROTECTION - PROVIDED BY INSTALLER	
(A) LOAD SPECIFICATIONS	(A) MOTOR LOAD EACH (FLA)	NONMELT DELAY FUSE	TIME-DELAY FUSE
(A) POWER (W/HP)	(A) MOTOR LOAD TOTAL (FLA)	INVERSE-TIME CIRCUIT BREAKER	
MOTOR SIZE EACH (HP)			
1 208V/3Ø	4.6	15A	10A
1.5 208V/3Ø	6.6	20A	15A
2 208V/3Ø	7.5	25A	20A
3 208V/3Ø	10.6	35A	20A
5 208V/3Ø	16.7	55A	30A
7.5 208V/3Ø	24.2	80A	45A
10 208V/3Ø	30.8	100A	60A
15 208V/3Ø	46.2	150A	85A
1 230V/3Ø	4.2	15A	10A
1.5 230V/3Ø	6.0	20A	15A
2 230V/3Ø	6.8	25A	20A
3 230V/3Ø	9.6	30A	20A
5 230V/3Ø	15.2	50A	30A
7.5 230V/3Ø	22.0	70A	40A
10 230V/3Ø	28.0	90A	55A
15 230V/3Ø	42.0	150A	75A
1 460V/3Ø	2.1	6A	6A
1.5 460V/3Ø	3.0	10A	6A
2 460V/3Ø	3.4	15A	10A
3 460V/3Ø	4.8	15A	10A
5 460V/3Ø	7.6	25A	15A
7.5 460V/3Ø	11.0	35A	20A
10 460V/3Ø	14.0	45A	25A
15 460V/3Ø	21.0	65A	40A
1 380V/3Ø	2.3	10A	6A
1.5 380V/3Ø	3.3	15A	10A
2 380V/3Ø	4.3	15A	10A
3 380V/3Ø	6.1	20A	15A
5 380V/3Ø	9.7	35A	20A
7.5 380V/3Ø	14	45A	30A
10 380V/3Ø	18	60A	35A
15 380V/3Ø	27	90A	50A
1 575V/3Ø	1.7	6A	6A
1.5 575V/3Ø	2.4	10A	6A
2 575V/3Ø	2.7	15A	10A
3 575V/3Ø	3.9	15A	10A
5 575V/3Ø	6.1	25A	15A
7.5 575V/3Ø	9.0	30A	20A
10 575V/3Ø	11.0	35A	25A
15 575V/3Ø	17.0	55A	35A

NOTE - VALUES ARE BASED ON NEC 2005 SEC 430. ADJUST OVERCURRENT PROTECTION DEVICE TO ACTUAL MOTOR NAMEPLATE FLA VALUE

* Main disconnect and branch circuit protection to be installed by a qualified electrician in accordance with national and local codes

Figure 8 - 3-5 HP Basemount/Simplex Three-Phase 460 Volts

Scroll Air Compressors Tankmount/Basemount

TABLE 1

PANEL DATA 1Ø - 50/60 HZ
100VA CONTROL CIRCUIT

(B) BRANCH CIRCUIT PROTECTION - PROVIDED BY INSTALLER

PANEL NUMBER	MOTOR SIZE EACH (HP)	(A) POWER (W/PH)	(A) MOTOR LOAD EACH (FLA)	PANEL TOTAL (FLA)	NONTIME DELAY FUSE	TIME-DELAY FUSE	INVERSE-TIME CIRCUIT BREAKER
PSI2002XAJ	2	208/230V/1Ø	12	26	50A	35A	45A
PSI2003XAJ	3	208/230V/1Ø	18.7	39	60A	40A	50A
PSI2005XAJ	5	208/230V/1Ø	30.8	63	90A	60A	80A

NOTE - ADJUST OVERCURRENT PROTECTION DEVICE TO MOTOR NAMEPLATE FLA VALUE

TABLE 2

CONTROL TRANSFORMERS - 100VA

FUSE TYPE	208 VOLT	230 VOLT	460 VOLT
FU1,2	FNQR 2A	2A	1A
FU3	FNM 1.25A	1.25A	1.25A

HIGH PRESSURE SWITCH SET POINTS

PSI	CUT IN	115PSI
PS1	CUT OUT	145PSI
PS2	CUT IN	95PSI
	CUT OUT	125PSI

PRESSURE SWITCH SET POINTS

PSI	CUT IN	90PSI
PS1	CUT OUT	120PSI
PS2	CUT IN	80PSI
	CUT OUT	110PSI

CONFIDENTIAL DISCLOSURE
This document is the property of SCOTT FETZER COMPANY and subject to return on demand. Its contents are controlled and not to be copied or disseminated without the express written permission of SCOTT FETZER COMPANY.

PANEL TYPE
IND DUP SCROLL
SINGLE PHASE 208V 230V

DWG. TYPE WIRING
DWG. NO.

PSI-200

SHEET
W-1

SIZE
B

PSI-500 B1

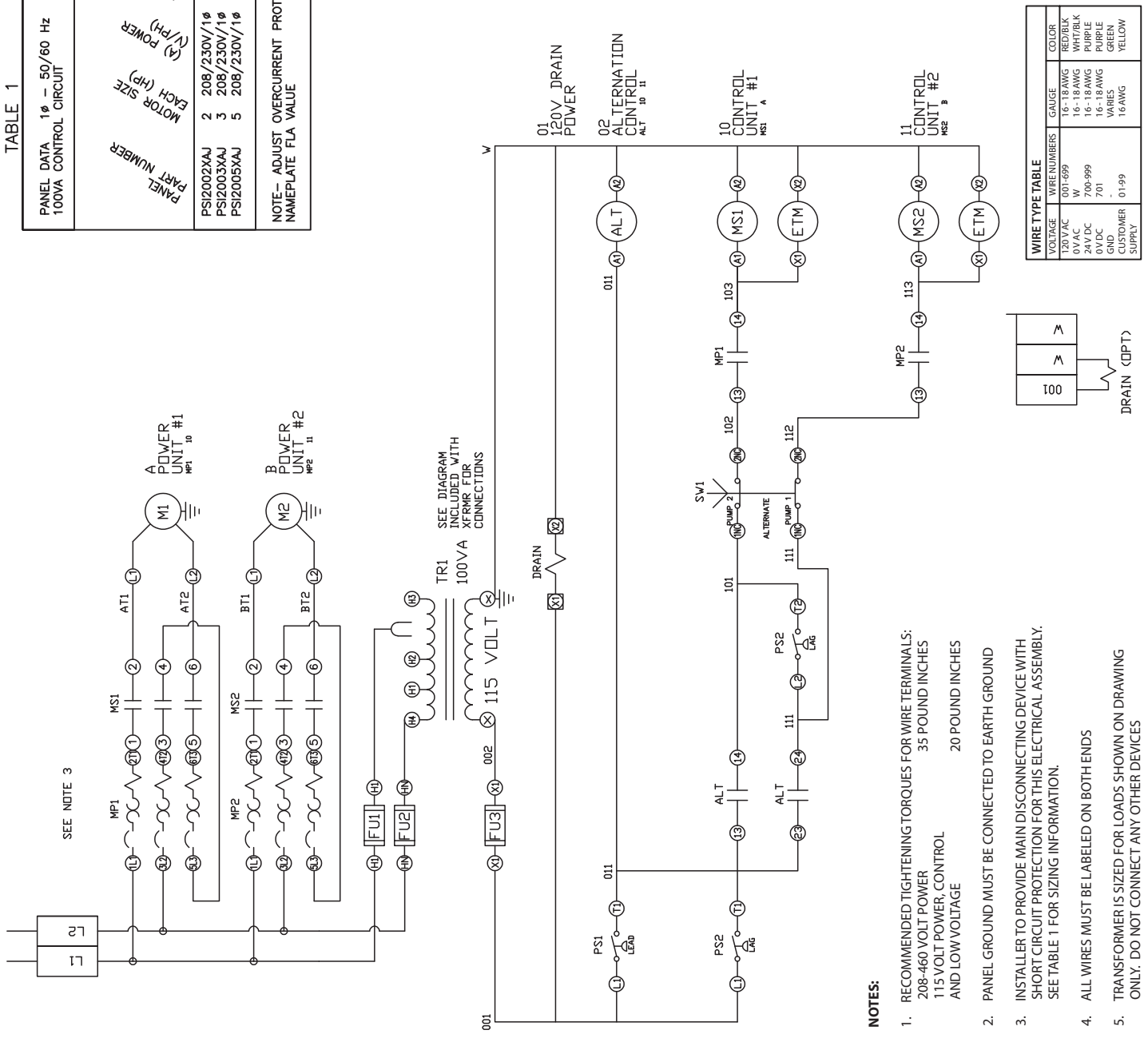

- NOTES:**
- RECOMMENDED TIGHTENING TORQUES FOR WIRE TERMINALS:
208-460 VOLT POWER 35 POUND INCHES
115 VOLT POWER, CONTROL AND LOW VOLTAGE 20 POUND INCHES
 - PANEL GROUND MUST BE CONNECTED TO EARTH GROUND
 - INSTALLER TO PROVIDE MAIN DISCONNECTING DEVICE WITH SHORT CIRCUIT PROTECTION FOR THIS ELECTRICAL ASSEMBLY. SEE TABLE 1 FOR SIZING INFORMATION.
 - ALL WIRES MUST BE LABELED ON BOTH ENDS
 - TRANSFORMER IS SIZED FOR LOADS SHOWN ON DRAWING ONLY. DO NOT CONNECT ANY OTHER DEVICES

Figure 9 - 3-5 HP Duplex Single-Phase 208-230 Volts

TABLE 1

PANEL DATA 3Ø - 60 Hz 100VA CONTROL CIRCUIT		PANEL LOAD		PANEL TOTAL (FLA)		BRANCH CIRCUIT PROTECTION - PROVIDED BY INSTALLER	
(A) LOAD SPECIFICATIONS		(1) MOTOR LOAD EACH (FLA)	(2) POWER EACH (HP)	(3) MOTOR LOAD EACH (FLA)	(4) TOTAL (FLA)	TIME-DELAY FUSE	INVERSE-TIME CIRCUIT BREAKER
PANEL PART NUMBER	MOTOR SIZE (HP)	(A) MOTOR LOAD EACH (FLA)	(2) POWER EACH (HP)	(3) MOTOR LOAD EACH (FLA)	(4) TOTAL (FLA)	TIME-DELAY FUSE	INVERSE-TIME CIRCUIT BREAKER
PSI20022XX	2	208V/3Ø	7.5	17	30A	20A	30A
PSI20032XX	3	208V/3Ø	10.6	23	45A	30A	40A
PSI20052XX	5	208V/3Ø	16.7	35	70A	45A	60A
PSI20023XX	2	230V/3Ø	6.8	15	30A	20A	25A
PSI20033XX	3	230V/3Ø	9.6	20	40A	30A	35A
PSI20053XX	5	230V/3Ø	15.2	32	60A	45A	50A
PSI20024XX	2	460V/3Ø	3.4	8	15A	10A	15A
PSI20034XX	3	460V/3Ø	4.8	11	20A	15A	20A
PSI20054XX	5	460V/3Ø	7.6	16	30A	20A	30A
PSI20028XX	2	380V/3Ø	4.3	10.6	20A	15A	20A
PSI20038XX	3	380V/3Ø	6.1	14.2	30A	20A	25A
PSI20058XX	5	380V/3Ø	9.7	21.4	45A	30A	40A
PSI20027XX	2	575V/3Ø	2.7	7.4	15A	10A	15A
PSI20037XX	3	575V/3Ø	3.9	9.8	20A	15A	20A
PSI20057XX	5	575V/3Ø	6.1	14.2	30A	20A	25A

NOTE - ADJUST OVERCURRENT PROTECTION DEVICE NOT TO EXCEED 115% OF MOTOR NAMEPLATE FLA VALUE

NOTE - FOR STANDARD PRESSURE SYSTEMS, USE PSI200XXAJ PART#, FOR HIGH PRESSURE SYSTEMS, USE PSI200XXHP PART#

TABLE 2

CONTROL TRANSFORMERS - 100VA		
FUSE TYPE	208 VOLT	460 VOLT
FU1,2	FNR	2A
FU3	FNM	1.25A

CONFIDENTIAL DISCLOSURE
This document is the property of the SCOTT FETZER COMPANY and subject to return on demand. Its contents are controlled and should not be copied or disseminated outside the company without the written permission of the SCOTT FETZER COMPANY.

PANEL TYPE
IND DUP SCROLL
3 PHASE

DWG. TYPE WIRING
DWG. NO. PSI-200

SHEET W-1
SIZE B

PSI-500 B1

HIGH PRESSURE SWITCH SET POINTS

PSI	CUT IN	115PSI	CUT OUT
PS1	CUT IN	145PSI	CUT OUT
PS2	CUT IN	95PSI	CUT OUT
PS2	CUT IN	125PSI	CUT OUT

PRESSURE SWITCH SET POINTS

PSI	CUT IN	90PSI <th>CUT OUT</th>	CUT OUT
PS1	CUT IN	120PSI	CUT OUT
PS2	CUT IN	80PSI	CUT OUT
PS2	CUT IN	110PSI	CUT OUT

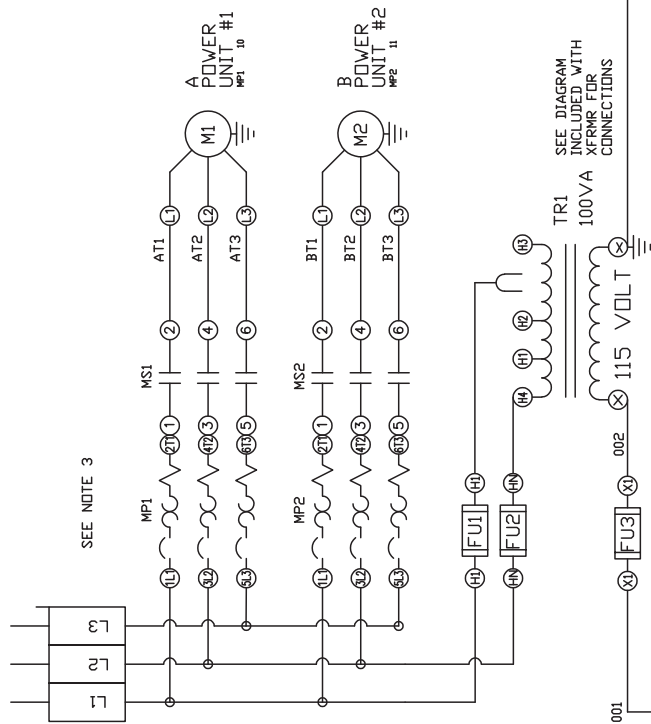

WIRE TYPE TABLE

VOLTAGE	WIRE NUMBERS	GAUGE	COLOR
120V AC	00T-699	16-18 AWG	RED/BLK
0V AC	W	16-18 AWG	WH/BLK
24V DC	700-999	16-18 AWG	PURPLE
0V DC	701	16-18 AWG	WHITE
CUSTOMER SUPPLY	01-99	16 AWG	GREEN YELLOW

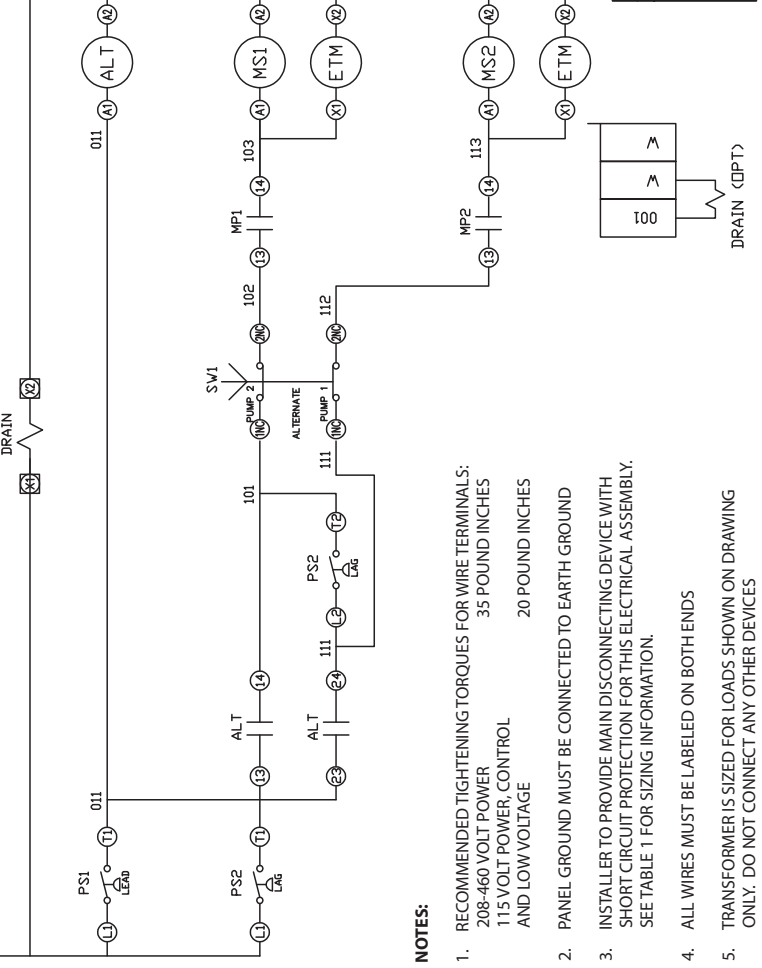

- NOTES:**
- RECOMMENDED TIGHTENING TORQUES FOR WIRE TERMINALS:
208-460 VOLT POWER 35 POUND INCHES
115 VOLT POWER, CONTROL AND LOW VOLTAGE 20 POUND INCHES
 - PANEL GROUND MUST BE CONNECTED TO EARTH GROUND
 - INSTALLER TO PROVIDE MAIN DISCONNECTING DEVICE WITH SHORT CIRCUIT PROTECTION FOR THIS ELECTRICAL ASSEMBLY. SEE TABLE 1 FOR SIZING INFORMATION.
 - ALL WIRES MUST BE LABELED ON BOTH ENDS
 - TRANSFORMER IS SIZED FOR LOADS SHOWN ON DRAWING ONLY. DO NOT CONNECT ANY OTHER DEVICES

Figure 10 - 3-5 HP Duplex Three-Phase 208-230/460/575 Volts

Scroll Air Compressors Tankmount/Basemount

Replacement Parts List for SBS Models

Ref. No.	Description	SBS Model Part Number	Qty.
1	Motor 3 HP 3 Phase	MC303301AV	1
	Motor 3 HP 1 Phase	MC022309AV	1
	Motor 5HP 3 Phase	MC303303AV	1
	Motor 5HP 1 Phase	MC022393AV	1
2	Base	BA000301AV	1
3	Angle bracket	ST185500AV	4
4	Beltguard back	BG303800AV	1
5	Bracket	SL050700AV	1
6	Beltguard front	BG303900AV	1
7	Beltguard bracket	SL302900AV	1
8 ▲	Belt:		
	3 HP	BT012001AV	2
	5 HP	BT010701AV	2
9 ▲	Motor pulley:		
	3 HP	PU202625AV	1
	3 HP (High Pressure Unit)	PU202624AV	1
	5 HP	PU009754AV	1
10	Pressure switch	CW207573AV	1
	Pressure switch (High Pressure Unit)	CW207595AV	1
11	Starter:		
	3 HP 230V 1 Phase	JP001071AJ	1
	5 HP 230V 1 Phase	IP001075AJ	1
	3 HP 230V 3 Phase	JP001073AJ	1
	5 HP 230V 3 Phase	JP001077AJ	1
	3 HP 460V 3 Phase	JP001074AJ	1
	5 HP 460V 3 Phase	JP001078AJ	1
12	90° Elbow	ST074204AV	1
13	1/2" Flare	ST126207AV	1
14	Discharge tube	SL300900AV	1
15	90° Flare elbow	ST126204AV	1
16	Aftercooler	SL300100AV	1
17	Aftercooler mounting bracket	AG007501AJ	4
18	Left/Right aftercooler bracket	SL300400AV	2
19 ▲	Check valve	IP087700AV	1
20 ▲	Safety valve	V-215104AV	1
	Safety valve (High Pressure Unit)	V-215401AV	1
21	Scroll air end:		
	3 HP	SL014003AJ	1
	5 HP	SL016502AJ	1
	5 HP (High Pressure Unit)	SL015611AJ	1

(▲) Not shown.

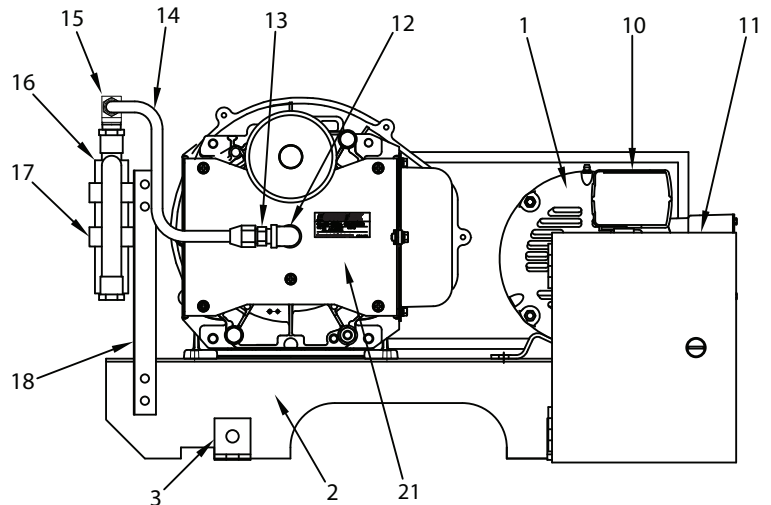
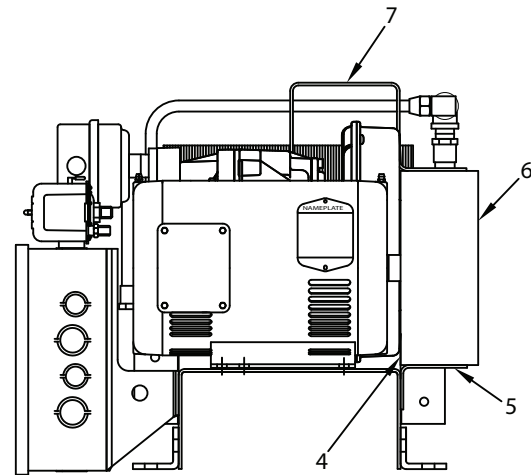

Replacement Parts List for STS Models

Ref. No.	Description	STS Model Part Number	Qty.
1	Motor:		
	3 HP 3 Phase	MC303301AV	1
	3 HP 1 Phase	MC022309AV	1
	5 HP 3 Phase	MC303303AV	1
2	Starter:		
	3 HP 230V 1 Phase	JP001071AJ	1
	5 HP 230V 1 Phase	IP001075AJ	1
	3 HP 230V 3 Phase	JP001073AJ	1
	5 HP 230V 3 Phase	JP001077AJ	1
	3 HP 460V 3 Phase	JP001074AJ	1
3	Receiver tank:		
	30 gallon	AR024700ST	1
	60 gallon	AR022500ST	1
4	Front beltguard	BG303900AV	1
5	Motor pulley:		
	3 HP	PU202625AV	1
	3 HP (High Pressure Unit)	PU202624AV	1
	5 HP	PU009754AV	1
6	Back beltguard	BG303800AV	1
7	Aftercooler	SL300100AV	1
8	Tube air end/aftercooler	SL300900AP	1
	Tube air end/aftercooler (High Pressure Unit)	SL300100AP	1
9	Tube aftercooler/tank	SL301400AP	1
	Tube aftercooler/tank (High Pressure Unit)	SL300900AP	1
10	Check valve	IP087700AV	1
11	Pressure gauge	GA016701AV	1
12	Safety valve	V-215104AV	1
12	Safety valve (High Pressure Unit)	V-215401AV	1
13	Pressure switch	CW207573AV	1
13	Pressure switch (High Pressure Unit)	CW207595AV	1
14	Scroll air end:		
	3 HP	SL014003AJ	1
	5 HP	SL016502AJ	1
	5 HP (High Pressure Unit)	SL015611AJ	1
15	Belt:		
	3 HP	BT012001AV	2
	5 HP	BT010701AV	2

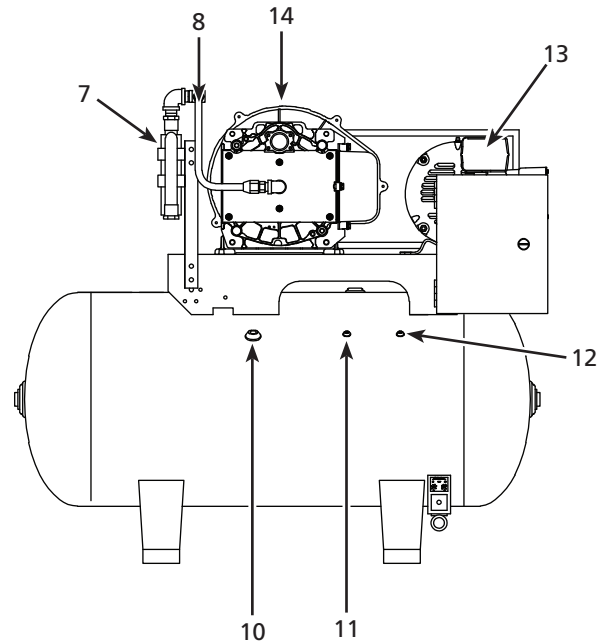
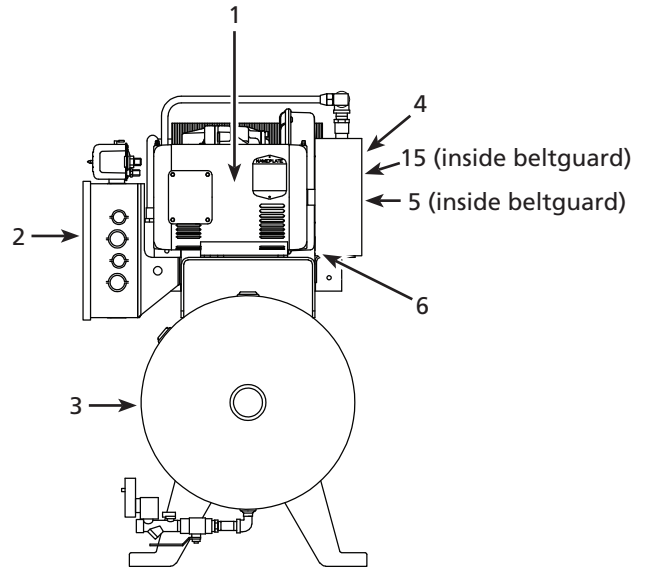

Scroll Air Compressors Tankmount/Basemount

Replacement Parts List for STD Models

Ref. No.	Description	STD Model Part Number	Qty.
1	Motor:		
	3 HP 3 Phase	MC303301AV	2
	3 HP 1 Phase	MC022309AV	2
	5 HP 3 Phase	MC303303AV	2
	5 HP 1 Phase	MC022393AV	2
2	Starter alternator panel:		
	3 HP 230V 1 Phase	PSI20036AJ	1
	5 HP 230V 1 Phase	PSI20056AJ	1
	3 HP 230V 3 Phase	PSI20033AJ	1
	5 HP 230V 3 Phase	PSI20053AJ	1
	3 HP 460V 3 Phase	PSI20034AJ	1
3	Receiver tank:		
	80 gallon	AR022900ST	1
	120 gallon	AR023600ST	1
4	Front beltguard	BG303900AV	1
5	Belt:		
	3 HP	BT012001AV	4
	5 HP	BT010701AV	4
6	Motor pulley:		
	3 HP	PU202625AV	2
	3 HP (High Pressure Unit)	PU202624AV	2
	5 HP	PU009754AV	2
7	Back beltguard	BG303800AV	2
8	Aftercooler	SL300100AV	2
9	Tube air end/aftercooler	SL300900AP	2
	Tube air end/aftercooler (High Pressure Unit)	SL300100AP	2
10	Tube aftercooler/tank	SL301400AP	2
	Tube aftercooler/tank (High Pressure Unit)	SL300900AP	2
11	Check valve	IP087700AV	2
12	Pressure gauge	GA016701AV	1
13	Safety valve	V-215104AV	1
	Safety valve (High Pressure Unit)	V-215401AV	1
14	Pressure switch (Lag)*	CW207595AV	1
15	Pressure switch (Lead)	CW207595AV	1
16	Scroll air end:		
	3 HP	SL014003AJ	2
	5 HP	SL016502AJ	2
	5 HP (High Pressure Unit)	SL015611AJ	2

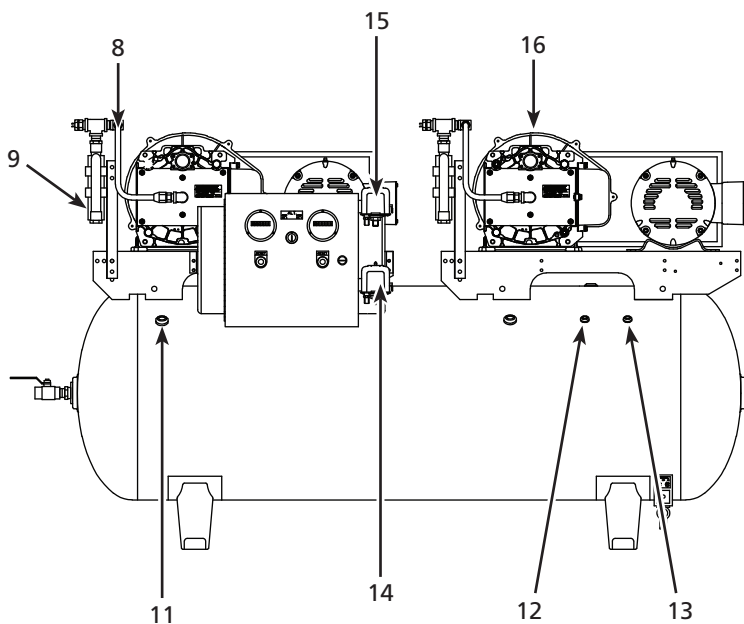
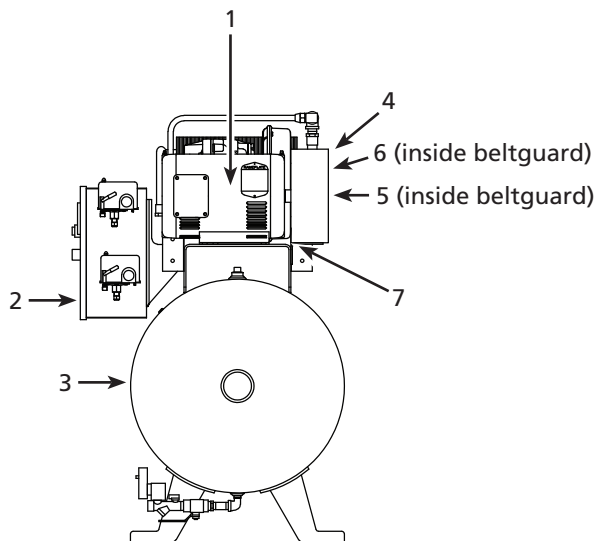

* Adjust to 5 psi below Lead switch.

Replacement Parts List for STS Models - Refrigerated Dryer Option

Ref. No.	Description	STS Model Part Number	Qty.
1	Refrigerated air dryer - 3HP	ACO016010	1
	Refrigerated air dryer - 5HP	ACO016015	1
2	Regulator	ST178408AJ	1
3	Electric auto tank drain	SL300701AV	1
4	.01 μ Filter	ST178184AV	1
5 ▲	.01 μ Filter element	ST178185AV	1

(▲) Not shown.

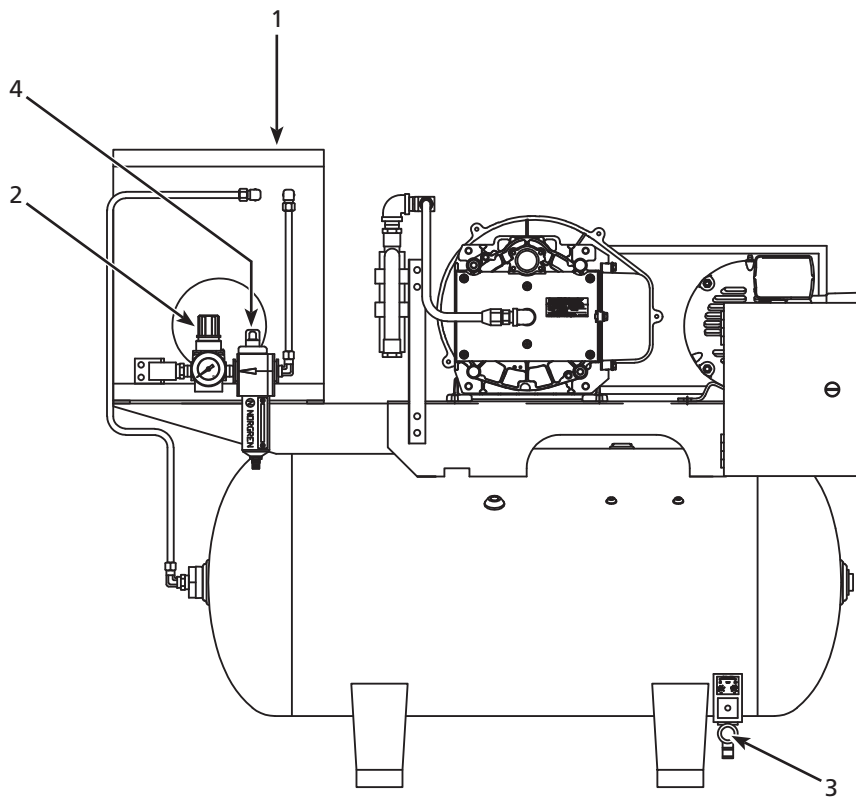

NOTE: Refer to page 13 for all STS model replacement parts not associated with the Refrigerated Dryer Option.

Scroll Air Compressors Tankmount/Basemount

Replacement Parts List for STD Models - Refrigerated Dryer Option

Ref. No.	Description	STD Model Part Number	Qty.
1	Refrigerated air dryer:		
	3 HP	ACO016025	1
	5 HP	ACO016035	1
2	Regulator	ST178409AV	1
3	Electric auto tank drain	SL300100AV	1
4	.01 μ Filter	ST178108AV	1
5 ▲	.01 μ Filter element	ST178109AV	1

(▲) Not shown.

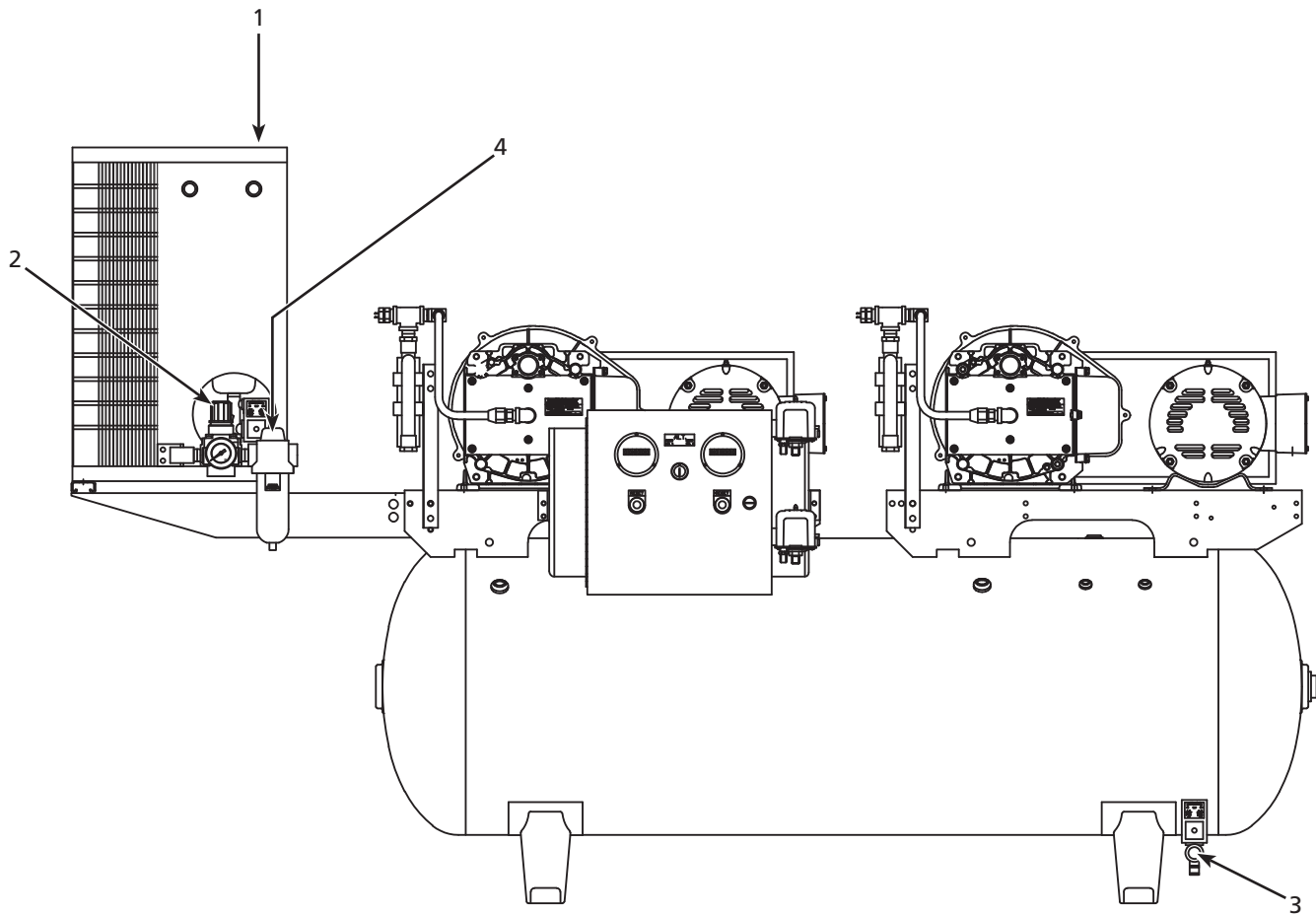

NOTE: Refer to page 14 for all STD model replacement parts not associated with the Refrigerated Dryer Option.

Troubleshooting Guide

PROBLEM	CAUSE	CORRECTIVE ACTION
Compressor unit will not start	<ol style="list-style-type: none"> 1. Main disconnect is not ON 2. Blown fuse or circuit breaker at customer provided power supply 3. Blown fuse at primary side of transformer (Duplex models) 4. Pressure switch is in OPEN position 	<ol style="list-style-type: none"> 1. Switch disconnect to ON 2. Inspect for any fault replace fuse or trip disconnect to ON 3. Replace fuse on primary side be sure use same type and size 4. Reduce pressure in tank
Power is at supply connection and compressor will not start	<ol style="list-style-type: none"> 1. Blown fuse on secondary side of transformer (Duplex models) 2. Motor overload has tripped 3. Wrong or low voltage 4. Starter has failed 5. Motor has failed 	<ol style="list-style-type: none"> 1. Replace fuse on secondary side be sure use same type and size 2. See last entry of Troubleshooting Guide 3. Check incoming power supply and unit power rating 4. Replace contactor assembly 5. Replace motor
Compressor is running but will not make pressure	<ol style="list-style-type: none"> 1. Drive belts came off or too loose 2. Clogged intake filter element 3. Pressure relief valve has opened 4. Excessive tip seal wear 5. Electric tank drain is open continuously 6. Unit running in the wrong direction 7. Discharge air is leaking 	<ol style="list-style-type: none"> 1. Replace drive belts and (or) tighten 2. Replace intake filter element 3. Pressure switch needs replaced or starter contacts welded shut 4. Replace tip seals 5. Clean/replace tank drain 6. Correct power connections 7. Check discharge piping
Excessive noise or vibration	<ol style="list-style-type: none"> 1. Drive belt has separated or flat spot 2. Motor has failed 3. Pump is damaged 4. Cooling air fan is touching fan guard 	<ol style="list-style-type: none"> 1. Replace drive belt 2. Replace motor 3. Fix or replace pump 4. Check air fan daily
Compressor running hot	<ol style="list-style-type: none"> 1. Room temperature is above 104° F 2. Inlet air duct is obstructed 3. Pump running at high pressure 4. Aftercooler fins clogged 5. Intake filter damaged 6. Compressor is dirty 	<ol style="list-style-type: none"> 1. Add ventilation or air conditioning to room 2. Remove obstruction or reposition unit to allow for cooling air 3. Confirm tank pressure and pump outlet are not obstructed 4. Clean aftercooler 5. Check intake filter 6. Clean unit
Compressor turns on/off rapidly	<ol style="list-style-type: none"> 1. Receiver tank has high level of water 2. Compressor check valve has failed 3. Defective pressure switch 	<ol style="list-style-type: none"> 1. Replace electric tank drain/drain tank 2. Replace check valve 3. Replace pressure switch
Safety valve blows off	<ol style="list-style-type: none"> 1. Pressure switch has failed to open 2. Motor starter contacts welded shut 	<ol style="list-style-type: none"> 1. Replace pressure switch 2. Replace motor starter
Motor Overload has tripped	<ol style="list-style-type: none"> 1. Pump has failed 2. Motor has failed 3. Improper wiring 4. Wrong overload setting 5. Low voltage 	<ol style="list-style-type: none"> 1. Fix or replace pump 2. Replace motor 3. Check wiring 4. Check overload setting 5. Check incoming power supply

Powerex Limited Warranty – Applicable to Non-OEM Customers in the U.S. & Canada Only

Warranty and Remedies.

(a) General. Powerex warrants each Compressor System, Vacuum System, Vacuum Pump, Compressor Air-End, or Powerex branded Accessory (collectively "Products", individually each a "Product") to be free from defects in material and workmanship ("Defects") at the date of shipment. This warranty shall apply only to Products that are purchased and used in the United States of America and in Canada. EXCEPT AS SET FORTH BELOW, NO OTHER WARRANTY, WHETHER EXPRESS OR IMPLIED, INCLUDING ANY WARRANTY OF MERCHANTABILITY OR FITNESS FOR A PARTICULAR PURPOSE, SHALL EXIST IN CONNECTION WITH THE SALE OR USE OF SUCH PRODUCTS. TO THE EXTENT PERMITTED BY LAW, ANY AND ALL IMPLIED WARRANTIES ARE EXCLUDED. All warranty claims must be made in writing and delivered to Powerex in accordance with the procedures set forth on its website (www.powerexinc.com), or such claim shall be barred. Upon timely receipt of a warranty claim, Powerex shall inspect the Product claimed to have a Defect, and Powerex shall repair, or, at its option, replace, free of charge, any Product which it determines to have had a Defect; provided, however, that if circumstances are such as to preclude the remedying of Defect by repair or replacement, Powerex shall, upon return of the Product, refund to buyer any part of the purchase price of such Products paid to Powerex. Freight for returning Products to Powerex for inspection shall be paid by buyer. The warranties and remedies herein are the sole and exclusive remedy for any breach of warranty or for any other claim based on any Defect, or non-performance of the Products, whether based upon contract, warranty or negligence.

(b) (i) Standard Period of Warranty – Parts and Labor - The purchase of any system includes our standard warranty. Powerex warrants and represents all Products shall be free from Defects for the first eighteen (18) months from the date of shipment by Powerex, or twelve (12) months from the documented date of startup, or five thousand (5,000) hours of use, whichever occurs first. During such warranty period, Powerex shall be fully liable for all Defects in the Products (the "Product Defects"), i.e., all costs of repair or replacement, which may include "in and out" charges, so long as the Products are located in the United States or Canada, and the Products are reasonably located and accessible by service personnel for removal. "In and out" charges include the costs of removing a Product from buyer's equipment for repair or replacement.

(ii) Premium Period of Warranty – Parts and Labor - In order to be eligible for premium warranty coverage, a premium warranty for each system must be purchased when order is placed. Powerex warrants and represents all Products shall be free from Defects for the first thirty (30) months from the date of shipment by Powerex, or twenty-four (24) months from the documented date of startup, or seven thousand five hundred (7,500) hours of use, whichever occurs first. During such warranty period, Powerex shall be fully liable for all Defects in the Products (the "Product Defects"), i.e., all costs of repair or replacement, which may include "in and out" charges, so long as the Products are located in the United States or Canada, and the Products are reasonably located and accessible by service personnel for removal. "In and out" charges include the costs of removing a Product from buyer's equipment for repair or replacement.

(c) Additional Period of Warranty – Parts Only (No Labor). In addition to the above, Powerex warrants each Powerex branded Compressor Air-End and Vacuum Pump shall be free of Defects for a period of forty-two (42) months from the date of shipment by Powerex, or thirty-six (36) months from the documented date of startup, or ten thousand (10,000) hours of use, whichever occurs first. Supplier's repair or replacement of any Product shall not extend the period of any warranty of any Product. This warranty applies to the exchange of part(s) found to be defective by an Authorized Powerex Service Representative only.

(d) Replacement Pumps – Parts Only (No Labor). For any replacement Air-End or Vacuum Pumps installed on a Powerex manufactured system or unit after any initial warranty period has expired or where another warranty does not apply for any reason, Powerex warrants that the Air-End or Vacuum Pumps shall be free of Defects for a period of thirty-six (36) months from the date of shipment by Powerex or ten thousand (10,000) hours of use, whichever comes first. For any replacement Air-End or Vacuum Pumps installed on a system that was not manufactured by Powerex after any initial warranty period has expired or where another warranty does not apply for any reason, Powerex warrants that the Air-End or Vacuum Pumps shall be free of Defects for the first twelve (12) months from the date of shipment by Powerex. Supplier's repair or replacement of any Product shall not extend the period of any warranty of any Product. This warranty applies to the exchange of part(s) found to be defective by an Authorized Powerex Service Representative only.

(e) Replacement Motors – Parts Only (No Labor). For any replacement motor installed on a Powerex manufactured system or unit after any initial warranty period has expired or where another warranty does not apply for any reason, Powerex warrants that the replacement motor shall be free of Defects for the first twelve (12) months from the date of shipment by Powerex. For any replacement motor installed on a system or unit that was not manufactured by Powerex after any initial warranty period has expired or where another warranty does not apply for any reason, Powerex warrants that the replacement motor shall be free of Defects for the first ninety (90) days from the date of shipment by Powerex. Supplier's repair or replacement of any Product shall not extend the period of any warranty of any Product. This warranty applies to the exchange of part(s) found to be defective by an Authorized Powerex Service Representative only.

(f) Replacement Parts – Parts Only (No Labor). For other replacement parts besides motors, Air-End or Vacuum Pumps installed on a Powerex manufactured system or unit after any initial warranty period has expired or where another warranty does not apply for any reason, Powerex warrants that such replacement parts will be free from Defects for the first twelve (12) months from the date of shipment by Powerex. For other replacement parts besides motors, Air-End or Vacuum Pumps installed on a system or unit that was not manufactured by Powerex after any initial warranty period has expired or where another warranty does not apply for any reason, Powerex makes no warranties. Supplier's repair or replacement of any Product shall not extend the period of any warranty of any Product. This warranty applies to the exchange of part(s) found to be defective by an Authorized Powerex Service Representative only.

(g) Coverage. The warranty provided herein applies to Powerex manufactured units or systems only.

(h) Exceptions. Notwithstanding anything to the contrary herein, Powerex shall have no warranty obligations with respect to Products:

- (i) that have not been installed in accordance with Powerex's written specifications and instructions;
- (ii) that have not been maintained in accordance with Powerex's written instructions;
- (iii) that have been materially modified without the prior written approval of Powerex; or
- (iv) that experience failures resulting from operation, either intentional or otherwise, in excess of rated capacities or in an otherwise improper manner.

Scroll Air Compressors Tankmount/Basemount

(i) The warranty provided herein shall not apply to:

- (i) any defects arising from corrosion, abrasion, use of insoluble lubricants, or negligent attendance to or faulty operation of the Products;
- (ii) ordinary wear and tear of the Products;
- (iii) defects arising from abnormal conditions of temperature, dirt or corrosive matter; or
- (iv) any OEM component which is shipped by Powerex with the original manufacturer's warranty, which shall be the sole applicable warranty for such component.

Limitation of Liability. NOTWITHSTANDING ANYTHING TO THE CONTRARY HEREIN, TO THE EXTENT ALLOWABLE UNDER APPLICABLE LAW, UNDER NO CIRCUMSTANCES SHALL POWEREX BE LIABLE FOR ANY INCIDENTAL, CONSEQUENTIAL, PUNITIVE, SPECULATIVE OR INDIRECT LOSSES OR DAMAGES WHATSOEVER ARISING OUT OF OR IN ANY WAY RELATED TO ANY OF THE PRODUCTS OR GOODS SOLD OR AGREED TO BE SOLD BY POWEREX TO BUYER. TO THE EXTENT ALLOWABLE UNDER APPLICABLE LAW, POWEREX'S LIABILITY IN ALL EVENTS IS LIMITED TO, AND SHALL NOT EXCEED, THE PURCHASE PRICE PAID.

Warranty Disclaimer. Powerex has made a diligent effort to illustrate and describe the Products in its literature, including its Price Book, accurately; however, such illustrations and descriptions are for the sole purpose of identification, and do not express or imply a warranty that the Products are merchantable, or fit for a particular purpose, or that the Products will necessarily conform to the illustrations or descriptions.

Product Suitability. Many jurisdictions have codes and regulations governing sales, construction, installation, and/or use of Products for certain purposes, which may vary from those in neighboring areas. While Powerex attempts to assure that its Products comply with such codes, it cannot guarantee compliance, and cannot be responsible for how the product is installed or used. Before purchase and use of a Product, please review the Product applications, and national and local codes and regulations, and be sure that the Product, installation, and use will comply with them.

Claims. Any non-warranty claims pertaining to the Products must be filed with Powerex within 6 months of the invoice date, or they will not be honored. Prices, discounts, and terms are subject to change without notice or as stipulated in specific Product quotations. Powerex shall not be liable for any delay or failure arising out of acts of the public enemy, fire, flood, or any disaster, labor trouble, riot or disorder, delay in the supply of materials or any other cause, whether similar or dissimilar, beyond the control of Company. All shipments are carefully inspected and counted before leaving the factory. Please inspect carefully any receipt of Products noting any discrepancy or damage on the carrier's freight bill at the time of delivery. Discrepancies or damage which obviously occurred in transit are the carrier's responsibility and related claims should be made promptly directly to the carrier. Returned Products will not be accepted without prior written authorization by Powerex and deductions from invoices for shortage or damage claims will not be allowed. **UNLESS OTHERWISE AGREED TO IN WRITING, THE TERMS AND CONDITIONS CONTAINED IN THIS LIMITED WARRANTY WILL CONTROL IN ANY TRANSACTION WITH POWEREX.** Any different or conflicting terms as may appear on any order form now or later submitted by the buyer will not control. All orders are subject to acceptance by Powerex.