



**HIGH PURITY PTFE AIR DIAPHRAGM PUMPS**

# HIGH PURITY MACHINED PTFE PUMPS



## PTFE PUMPS

- Machined PTFE Design
- NPT/BSP or ANSI/DIN Flange Connections
- 1/4, 3/8, 1/2, 1, 1-1/2, 2 Inch Sizes Available
- Max Temperature 248°F (120°C)
- Maximum Flow 150 GPM (565 lpm)

	T025	T038	T050	T100	T150	T200
<b>DIMENSION</b>						
Air Inlet	1/8"	1/8"	1/4"	1/4"	1/2"	1/2"
Liquid Inlet	1/4"	3/8"	1/2"	1"	1-1/2"	2"
Liquid Outlet	1/4"	3/8"	1/2"	1"	1-1/2"	2"
Weight	3.3 lbs (1.5 kg)	5.3 lbs (2.4 kg)	15 lbs (6.8 kg)	36.4 lbs (16.5 kg)	98.1 lbs (44.5 kg)	192 lbs (87 kg)
<b>PERFORMANCE</b>						
Max capacity	2.6 gpm (10 lpm)	6.4 gpm (25 lpm)	14.5 gpm (55 lpm)	33 gpm (125 lpm)	83 gpm (315 lpm)	150 gpm (565 lpm)
Max pressure	120 psi (8.2 bar)					
Max Solids	1/16" (2 mm)	1/8" (3 mm)	1/8" (4 mm)	1/4" (7 mm)	3/8" (10 mm)	7/16" (12 mm)
Suction lift dry	1.6 ft-H <sub>2</sub> O (0.5 m-H <sub>2</sub> O)	6.6 ft-H <sub>2</sub> O (2 m-H <sub>2</sub> O)	9.8 ft-H <sub>2</sub> O (3 m-H <sub>2</sub> O)	13.1 ft-H <sub>2</sub> O (4 m-H <sub>2</sub> O)	13.1 ft-H <sub>2</sub> O (4 m-H <sub>2</sub> O)	16.4 ft-H <sub>2</sub> O (5 m-H <sub>2</sub> O)
Suction lift wet	29.5 ft-H <sub>2</sub> O (9.0 m-H <sub>2</sub> O)					
Temperature limits	230°F (110°C)	230°F (110°C)	248°F (120°C)	248°F (120°C)	248°F (120°C)	248°F (120°C)

# MODEL DESIGNATION MATRIX

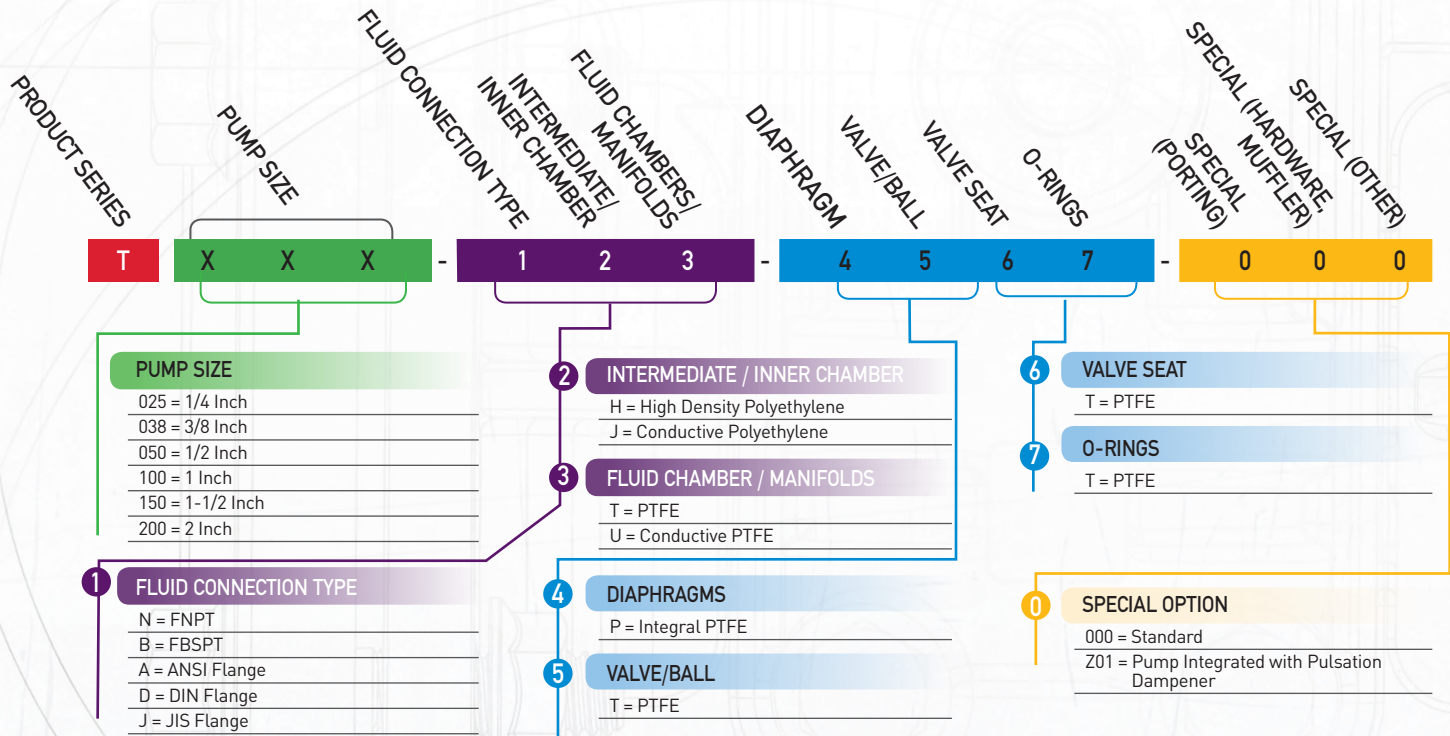

\*Additional fluid connection types available on upon request. Contact factory for details.

## WET END REPAIR KIT

Wet end kit contains 2 diaphragms, (2 back-up diaphragms if required), 4 balls, 4 seats, and 4 seat o-rings.



## PUMP REPAIR KIT

Pump repair kit consists of complete wet end and air end components

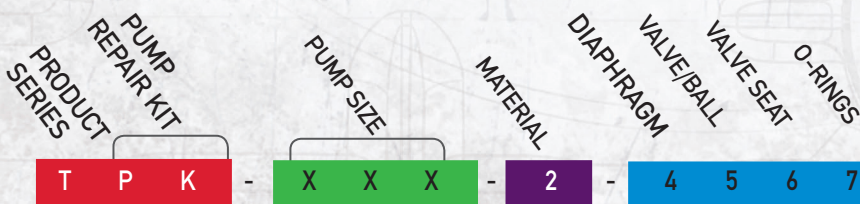

**2 INTERMEDIATE / INNER CHAMBER**  
 H = High Density Polyethylene  
 J = Conductive Polyethylene

all-flo.com

## CONNECTION TYPES

BSP & NPT

ANSI & DIN FLANGE

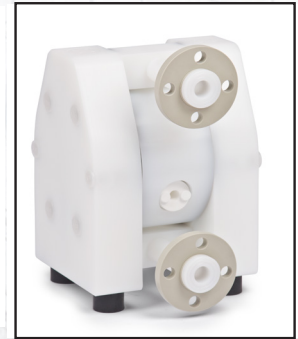

NON-CONDUCTIVE

CONDUCTIVE

## CONDUCTIVITY



# PERFORMANCE CURVES

## PERFORMANCE CURVE - T025

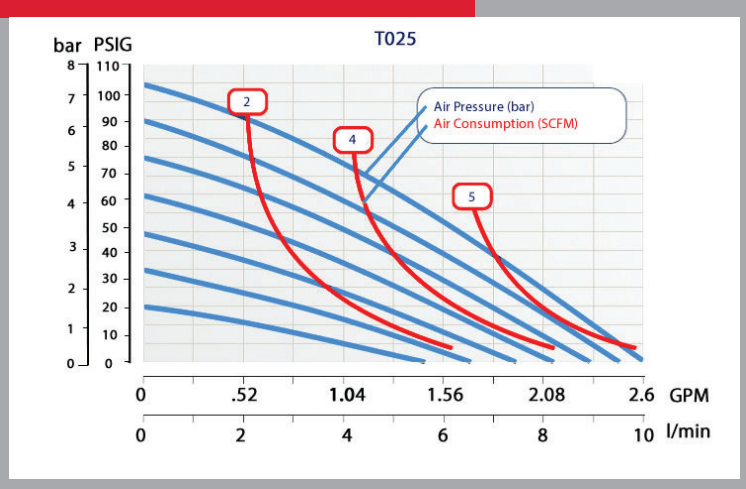

## T025 Performance Specifications

Max. Flow:	2.6 gpm (10 lpm)
Max. Air Pressure:	120 psi (8.2 bar)
Max. Solids:	1/16" (2 mm)
Max. Suction Lift Dry:	1.6 ft-H <sub>2</sub> O (0.5 m-H <sub>2</sub> O)
Max. Suction Lift Wet:	29.5 ft-H <sub>2</sub> O (9 m-H <sub>2</sub> O)
Weight:	3.3 lbs (1.5 kg)
Air Inlet:	1/8"
Liquid Inlet:	1/4"
Liquid Outlet:	1/4"
Height:	5.12" (130 mm)
Width:	4.5" (114 mm)
Depth:	2.76" (70 mm)

## PERFORMANCE CURVE - T038

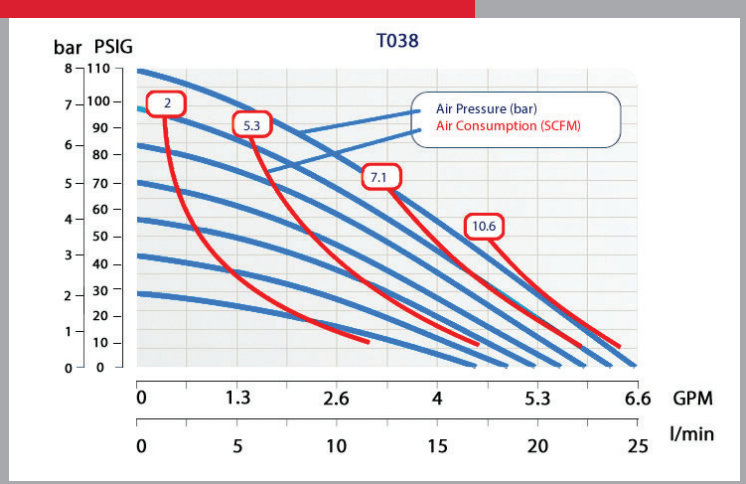

## T038 Performance Specifications

Max. Flow:	6.4 gpm (25 lpm)
Max. Air Pressure:	120 psi (8.2 bar)
Max. Solids:	1/8" (3 mm)
Max. Suction Lift Dry:	6.6 ft-H <sub>2</sub> O (2 m-H <sub>2</sub> O)
Max. Suction Lift Wet:	29.5 ft-H <sub>2</sub> O (9 m-H <sub>2</sub> O)
Weight:	5.3 lbs (2.4 kg)
Air Inlet:	1/8"
Liquid Inlet:	3/8"
Liquid Outlet:	3/8"
Height:	6.86" (174 mm)
Width:	5.04" (128 mm)
Depth:	4.13" (105 mm)

## PERFORMANCE CURVE - T050

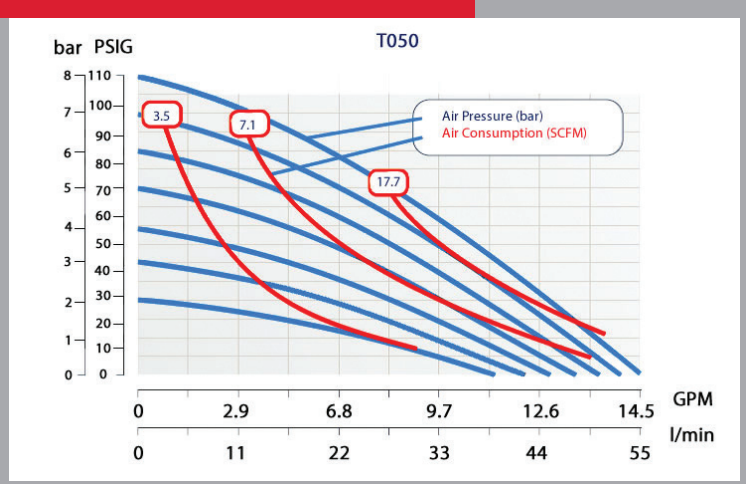

## T050 Performance Specifications

Max. Flow:	14.5 gpm (55 lpm)
Max. Air Pressure:	120 psi (8.2 bar)
Max. Solids:	1/8" (4 mm)
Max. Suction Lift Dry:	9.8 ft-H <sub>2</sub> O (3 m-H <sub>2</sub> O)
Max. Suction Lift Wet:	29.5 ft-H <sub>2</sub> O (9 m-H <sub>2</sub> O)
Weight:	15 lbs (6.8 kg)
Air Inlet:	1/4"
Liquid Inlet:	1/2"
Liquid Outlet:	1/2"
Height:	9.96" (253 mm)
Width:	6.97" (177 mm)
Depth:	6.02" (153 mm)

# PERFORMANCE CURVES

## PERFORMANCE CURVE - T100

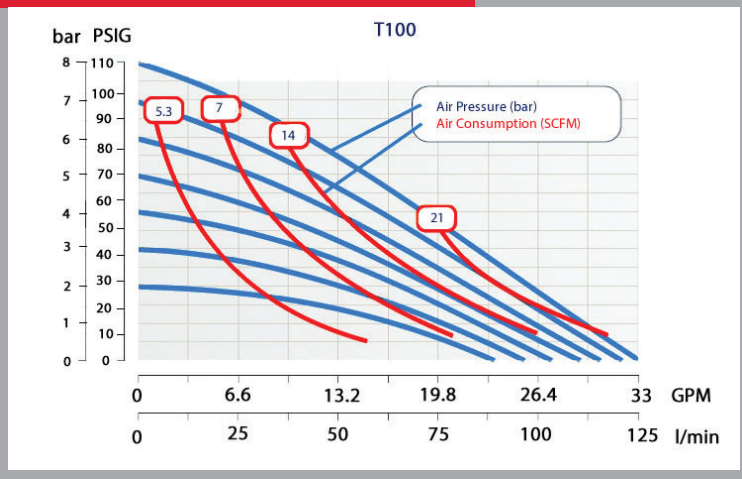

## T100 Performance Specifications

Max. Flow:	33 gpm (125 lpm)
Max. Air Pressure:	120 psi (8.2 bar)
Max. Solids:	1/4" (7 mm)
Max. Suction Lift Dry:	13.1 ft-H <sub>2</sub> O (4 m-H <sub>2</sub> O)
Max. Suction Lift Wet:	29.5 ft-H <sub>2</sub> O (9 m-H <sub>2</sub> O)
Weight:	36.4 lbs (16.5 kg)
Air Inlet:	1/4"
Liquid Inlet:	1"
Liquid Outlet:	1"
Height:	13.38" (340 mm)
Width:	9.13" (232 mm)
Depth:	7.78" (198 mm)

## PERFORMANCE CURVE - T150

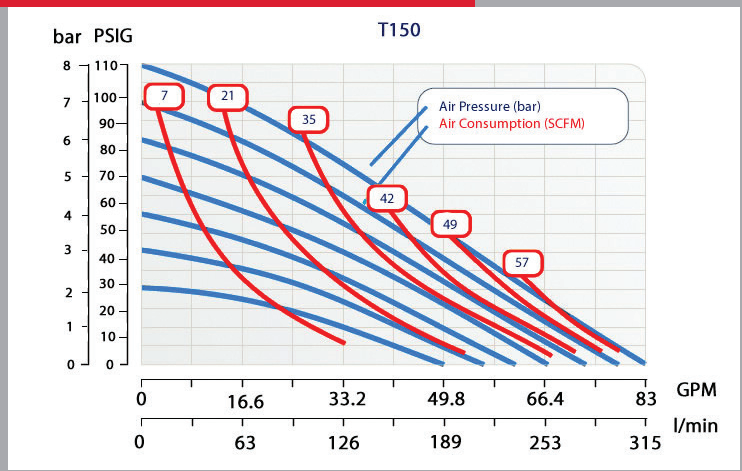

## T150 Performance Specifications

Max. Flow:	83 gpm (315 lpm)
Max. Air Pressure:	120 psi (8.2 bar)
Max. Solids:	3/8" (10 mm)
Max. Suction Lift Dry:	13.1 ft-H <sub>2</sub> O (4 m-H <sub>2</sub> O)
Max. Suction Lift Wet:	29.5 ft-H <sub>2</sub> O (9 m-H <sub>2</sub> O)
Weight:	98.1 lbs (44.5 kg)
Air Inlet:	1/2"
Liquid Inlet:	1-1/2"
Liquid Outlet:	1-1/2"
Height:	17.95" (456 mm)
Width:	12.28" (312 mm)
Depth:	10.63" (270 mm)

## PERFORMANCE CURVE - T200

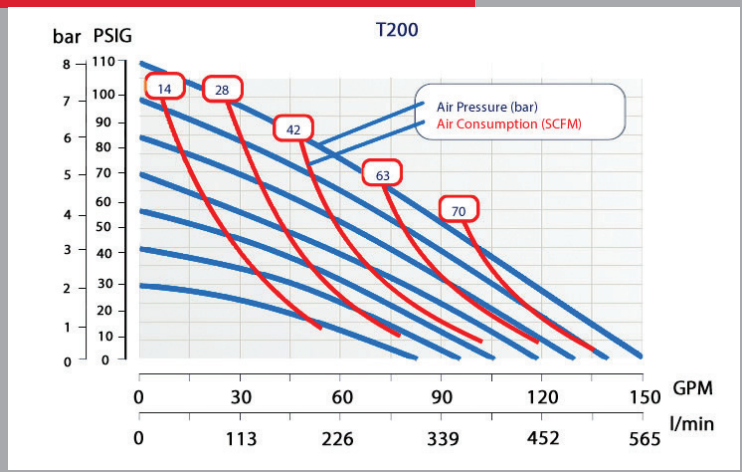

## T200 Performance Specifications

Max. Flow:	150 gpm (565 lpm)
Max. Air Pressure:	120 psi (8.2 bar)
Max. Solids:	7/16" (12 mm)
Max. Suction Lift Dry:	16.4 ft-H <sub>2</sub> O (5 m-H <sub>2</sub> O)
Max. Suction Lift Wet:	29.5 ft-H <sub>2</sub> O (9 m-H <sub>2</sub> O)
Weight:	192 lbs (87 kg)
Air Inlet:	1/2"
Liquid Inlet:	2"
Liquid Outlet:	2"
Height:	22.44" (570 mm)
Width:	15.16" (385 mm)
Depth:	13.78" (350 mm)

# PUMP DIMENSIONS

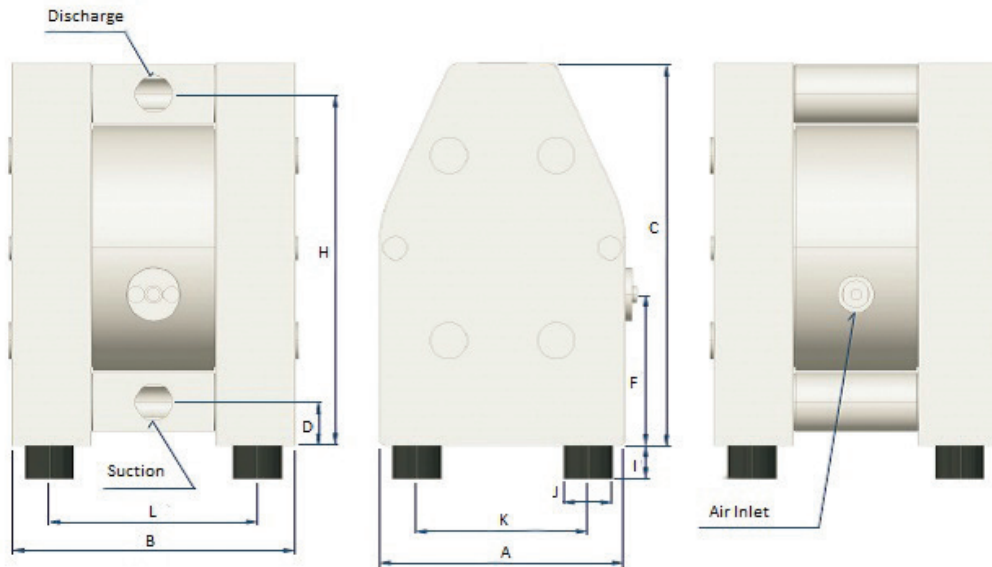

	A	B	C	D	F	H	I	J	K	L
T025	2.76" (70 mm)	4.5" (113 mm)	4.72" (120 mm)	.59" (15 mm)	2.28" (58 mm)	4.23" (107 mm)	.40" (10 mm)	.60" (15 mm)	1.97" (50 mm)	3.39" (86 mm)
T038	44.13" (105 mm)	5.04" (128 mm)	6.46" (164 mm)	.71" (18 mm)	3.31" (84 mm)	5.91" (150 mm)	.40" (10 mm)	.60" (15 mm)	2.95" (75 mm)	3.66" (93 mm)
T050	6.02" (153 mm)	6.97" (177 mm)	9.25" (235 mm)	.98" (25 mm)	3.43" (87 mm)	8.54" (217 mm)	.71" (18 mm)	1.18" (30 mm)	4.41" (112 mm)	5.35" (136 mm)
T100	7.78" (200 mm)	9.13" (232 mm)	12.28" (312 mm)	1.38" (35 mm)	4.84" (123 mm)	11.3" (287 mm)	1.10" (28 mm)	1.58" (40 mm)	5.51" (140 mm)	6.70" (170 mm)
T150	110.63" (270 mm)	12.28" (312 mm)	16.77" (426 mm)	1.65" (42 mm)	4.29" (109 mm)	15.28" (388 mm)	1.18" (30 mm)	2.36" (60 mm)	7.48" (190 mm)	8.94" (227 mm)
T200	113.78" (350 mm)	15.16" (385 mm)	21.26" (540 mm)	1.77" (45 mm)	6.22" (158 mm)	19.09" (485 mm)	1.18" (30 mm)	2.36" (60 mm)	10.63" (270 mm)	11.10" (282 mm)

# DIMENSIONS - INTEGRATED DAMPENER

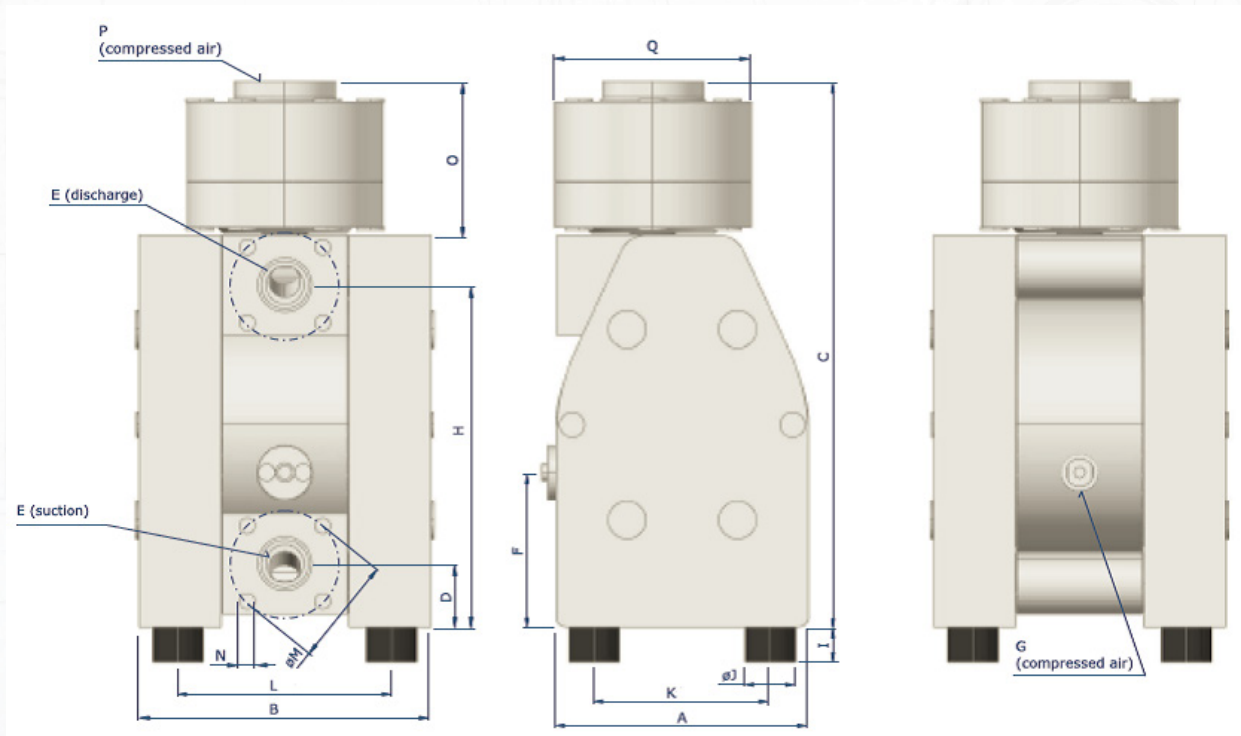

	A	B	C	D	E	F	G	H	I	J	K	L	M	N	O	P	Q
<b>T025</b>	2.76" (70 mm)	4.5" (113 mm)	4.72" (120 mm)	.59" (15 mm)	1/4" (6.35 mm)	2.28" (58 mm)	1/8" (3.18 mm)	4.23" (107 mm)	.40" (10 mm)	.60" (15 mm)	1.97" (50 mm)	3.39" (86 mm)	-	-	2.91" (74 mm)	1/8" (3.18 mm)	2.91" (73 mm)
<b>T038</b>	44.13" (105 mm)	5.04" (128 mm)	6.46" (164 mm)	.71" (18 mm)	3/8" (9.53 mm)	3.31" (84 mm)	1/8" (3.18 mm)	5.91" (150 mm)	.40" (10 mm)	.60" (15 mm)	2.95" (75 mm)	3.66" (93 mm)	-	-	3.19" (81 mm)	1/8" (3.18 mm)	4.09" (104 mm)
<b>T050</b>	6.02" (153 mm)	6.97" (177 mm)	9.25" (235 mm)	.98" (25 mm)	1/2" (12.7 mm)	3.43" (87 mm)	1/4" (6.35 mm)	8.54" (217 mm)	.71" (18 mm)	1.18" (30 mm)	4.41" (112 mm)	5.35" (136 mm)	2.56" (65 mm)	1/2" (12.7 mm)	3.19" (81 mm)	1/8" (3.18 mm)	4.09" (104 mm)
<b>T100</b>	7.78" (200 mm)	9.13" (232 mm)	12.28" (312 mm)	1.38" (35 mm)	1" (25.4 mm)	4.84" (123 mm)	1/4" (6.35 mm)	11.3" (287 mm)	1.10" (28 mm)	1.58" (40 mm)	5.51" (140 mm)	6.70" (170 mm)	3.35" (85 mm)	1/2" (12.7 mm)	4.69" (119 mm)	1/8" (3.18 mm)	6.14" (156 mm)
<b>T150</b>	10.63" (270 mm)	12.28" (312 mm)	16.77" (426 mm)	1.65" (42 mm)	1-1/2" (38.1 mm)	4.29" (109 mm)	1/2" (12.7 mm)	15.28" (388 mm)	1.18" (30 mm)	2.36" (60 mm)	7.48" (190 mm)	8.94" (227 mm)	4.33" (110 mm)	5/8" (15.88 mm)	5.94" (151 mm)	1/4" (6.35 mm)	8.03" (204 mm)
<b>T200</b>	13.78" (350 mm)	15.16" (385 mm)	21.26" (540 mm)	1.77" (45 mm)	2" (50.8 mm)	6.22" (158 mm)	1/2" (12.7 mm)	19.09" (485 mm)	1.18" (30 mm)	2.36" (60 mm)	10.63" (270 mm)	11.10" (282 mm)	4.92" (125 mm)	5/8" (15.88 mm)	7.20" (183 mm)	1/4" (6.35 mm)	10.75" (273 mm)



AUTO/PLATING & FINISHING



CERAMIC SLIP / GLAZE



CHEMICAL / PETROCHEMICAL



FOOD & BEVERAGE



MINING



OEMS



OIL & GAS / REFINERY



PAINT & COATING

ALL-FLO is committed to the pursuit of designing and manufacturing the highest quality product available to industry. Since the beginning in 1986, All-Flo engineers have used their extensive knowledge of today's engineered materials, advanced air system logic and manufacturing techniques to develop the superior group of lube-free, air-operated diaphragm pumps found in this catalog. Every pump is performance engineered and quality built to provide trouble-free service under the toughest conditions.



7750 Tyler Blvd.  
Mentor, Ohio 44060  
phone: 440.354.1700  
fax: 440.354.9466  
all-flo.com

13965-TXXX\_Rev\_A5

YOUR AUTHORIZED ALL-FLO DISTRIBUTOR