

Congratulations on your choice of a Real Good Toys product. Your kit has been precision made with meticulous care by our craftspeople using carefully selected materials. This Dollhouse will last for years, even generations, if heirloom care and attention is given during assembly. Take your time and read the instructions completely. If you have questions, ask the experts at your local Dollhouse store or at [info@realgoodtoys.com](mailto:info@realgoodtoys.com)

**Before you begin** - You have already opened the box and see all the parts organized in boxes and bundles. For the moment, keep them that way. There are important things to do before you open your glue bottle.

**Prepare your space:** This dollhouse will spread out over a large area while it is being built. You will need a large flat tabletop for the house, several boxes to keep parts organized until they are needed, and several trays lined with waxed paper for holding small parts like windows and railings. A snap-lid box will keep your tools and supplies handy between building sessions.

**Preview the Overview** (page 3) to plan and organize your build; this helps make it fun and fulfilling.

**Measure and identify the parts:** The kit is packed in groupings that protect the parts, and that is how the Parts List is organized. As you measure and identify the parts, label them with sticky notes using the names from the parts list, and check them off the parts list so you know you have everything. *Taking the time now to identify and organize the parts also makes them familiar so you will understand what the instructions intend* as you read ahead.

- Plan ahead so you know where you are going
- Read ahead so you know how to get there
- Paint ahead so the parts will be ready when you need them

**JM907 and JM33**  
Each available separately



The JM-33 Addition can be assembled to fit on either side of the Alison Jr. Cutting doors into the Addition is only recommended with a left Addition.

**Supplies:**

**Paint:** Interior semi-gloss latex paint... Everything gets at least one coat before assembly - get the paint now.

**Paintbrushes** 1" or 2" foam brushes for each color, 3" foam roller for interior painting

**Sandpaper:** 320 grit, 3-5 sheets

**Glue:** Aleene's Tacky Glue for the dollhouse

**Masking tape:** 3/4" or 1"

**Wiring:** it's easiest to install some parts during assembly... order wiring supplies now.

**Wallpaper paste:** Roman's "Border" Paste

Not suitable for children under 13 years of age  
California 93120 compliant for formaldehyde phase 2

# Customizing? Options for building Real Good Toys' Dollhouses

**Exterior:**

Exterior Paint Color:  
see [www.RealGoodToys.help](http://www.RealGoodToys.help) for suggestions

Accessories:

- Gingerbread
- Flower Boxes
- Foundation Stucco Grit
- Fancy Windows and Doors
- Turnposts and Spindles

**Interior:**

- Wiring
- Wallpaper
- Interior paint color:
  - Ceilings
  - Painted walls
  - Interior trim
- Flooring:
  - Applied wood, tile, or carpet
- Window and Door trim
- Baseboard and Crown

**Trim and Stripwood**

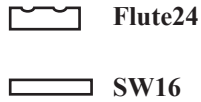

**Wallpaper**



**Doors:**

#6022



opening: 3<sup>1</sup>/<sub>16</sub> x 7<sup>9</sup>/<sub>16</sub>

#1015



opening: 3<sup>1</sup>/<sub>16</sub> x 7<sup>1</sup>/<sub>16</sub>

**Windows: available working or non-working**



#5042



#5041

**Parts List:** Measurements are approximate and are for identification purposes only

- (1) J0511 Base Floor: (1/4 Scored) 8<sup>7</sup>/<sub>8</sub> x 10<sup>1</sup>/<sub>4</sub>
- (1) J0510 Mid Floor: (3/8 Scored) 8<sup>7</sup>/<sub>8</sub> x 10<sup>1</sup>/<sub>4</sub>
- (1) J0501 Front: (3/8 Milled) 18<sup>3</sup>/<sub>32</sub> x 9<sup>3</sup>/<sub>32</sub>, Window cutouts
- (1) J0502 Side: (3/8 Milled) 18<sup>3</sup>/<sub>32</sub> x 10<sup>1</sup>/<sub>8</sub>
- (1) J0503 Liner: (1/8) 9 x 10<sup>1</sup>/<sub>8</sub>
- (1) J0504 Liner: (1/8) 8<sup>1</sup>/<sub>2</sub> x 10<sup>1</sup>/<sub>8</sub>
- (1) J0505 Top: (1/2) 9<sup>15</sup>/<sub>16</sub> x 11<sup>5</sup>/<sub>16</sub>
- (2) J0506 SideFoundation (Alison): (1/2) 9<sup>1</sup>/<sub>4</sub> x 1<sup>1</sup>/<sub>4</sub>
- (2) J0507 FrontFoundation (Alison): (1/2) 9<sup>1</sup>/<sub>8</sub> x 1<sup>1</sup>/<sub>4</sub>
- (2) J0508 SideFoundation (Farmhouse): (1/2) 9<sup>1</sup>/<sub>4</sub> x 3/4
- (2) J0509 FrontFoundation (Farmhouse): (1/2) 9<sup>1</sup>/<sub>8</sub> x 3/4
- (1) E3626 Flower Box: (1/2) 3/4 x 3<sup>3</sup>/<sub>4</sub> Angles

**Windows and Shutters**

- (8) T1020 Vertical Frame: (Molding) 5<sup>5</sup>/<sub>16</sub> Angles
- (8) T1021 Horizontal Frame: (Molding) 2<sup>13</sup>/<sub>16</sub> Angles
- (4) E3632 Shutter Core: (1/8) 1 x 4<sup>5</sup>/<sub>8</sub>
- (8) E3633 Shutter Panel: (1/16) 3/4 x 1<sup>7</sup>/<sub>8</sub>
- (2) T1022 Window Pane: 2<sup>1</sup>/<sub>2</sub> x 5

**Trim**

- (3) E6444 Post: (1/2 Flute post) 7/8
- (3) E9009 3/8 Bead
- (12) E6443 Bracket: (Molding) 1/4

**Strips**

- (2) J0512 Stripwood: (3/32) 7/16 x 18<sup>3</sup>/<sub>32</sub>
- (1) J0513 Cresting: (1/8 Die Cut) 9<sup>15</sup>/<sub>16</sub>
- (1) J0514 Cresting: (1/8 Die Cut) 7<sup>3</sup>/<sub>4</sub>



Identify the parts: Open one bundle at-a-time. Measure each part and find it on the parts list. Label the parts and, as you preview the instructions, group them as they will be used.

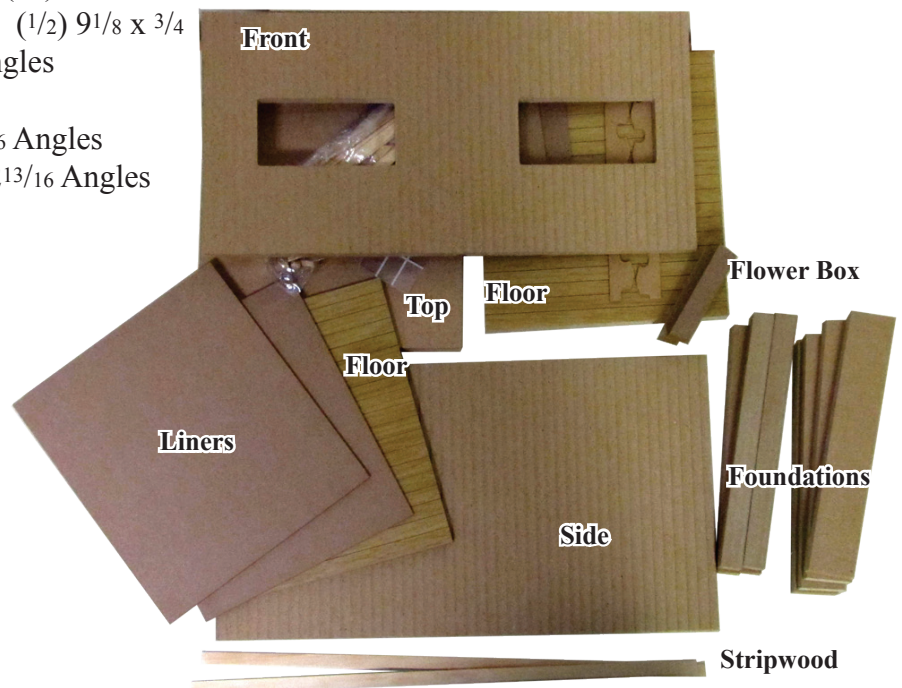

**Assembly Tips:**

A large, clutter-free, well-lighted work area is helpful during assembly, but a flat work surface is essential.

Read the instructions carefully; look at each of the illustrations. *!With the parts in your hands!*, think the assembly through before you proceed.

Test fit each time you are ready to glue a piece in place... then you'll know you have it right.

If more tape or a helper is needed, it's good to know that before the parts have glue on them.

Don't be stingy with glue or tape; use generous amounts. Always wipe off excess glue immediately.

Keep one damp rag and one dry rag handy all the time.

Have weights available for holding things tight as glue joints dry (stacks of books, gallons of pure Vermont Maple Syrup - anything heavy)

Glue the body of your dollhouse together with white, water clean-up glue that dries clear. Do not use instant-bond (super glue), fast-tack, rubber cement, silicone, or hot melt glues. They are all used in some wood applications, but they all have some characteristic that makes them undesirable for the body of your dollhouse. Carpenter Glue works well, but glue-smear dries yellow or tan; many of the things you glue onto the house are pre-painted – extra glue will show. I use Aleene's Tacky Glue® for all house body assembly.

Make sure everything is straight and flat as glue dries...

That's the shape that will be permanent.

If you Wallpaper, use pre-mixed Roman's "Border" paste. Brush paste on the wallpaper, then the wall, and finally smooth the wallpaper into position.

Taking things apart: Heat softens glue. If you have to take things apart, warm the part in the oven at 170° for up to a half hour to let the heat get into the joint where the glue is. Don't let it get hotter than you can touch or the paint may scorch. Don't heat window panes.

When glue is drying, skip ahead to up-coming assembly steps and prepare the parts that will be used

Before you begin, read the "Finish the Inside" section on the last page.

Slideshows, demos, useful links, details, and photos are all at:

[www.RealGoodToys.help](http://www.RealGoodToys.help)

**Overview of the Build:**

**Details of each step will be expanded along the way, but lots of folks like to see how it all fits together before they start**

Identify and label all of the parts

Pre-Assemble: Window Frames, Foundation

Paint everything one coat

Urethane the floors 1 coat, wiping off all surface excess

Sand everything until the paint is smooth, transparent, and some of the wood is showing through

Sand and second-coat the floors

Test the floors in the grooves

Build the walls, floors, and liners (cut doors in the Liners?)

Build the Foundation

Optional: locate and cut doors in the House Sidewall

Attach the Extension Foundation to the House Foundation

Second-coat the Walls

Attach the Extension Body to the House and Foundation

Mark, Paint, and attach the Rooftop to the Extension

Optional: wiring

Assemble and finish painting everything else

Finish the outside

Finish the inside

---

Q: Can I wallpaper before I assemble the doll house?

A: Yes you can (it's your house!) Many experienced builders are advocates of papering before construction - I am not.

My biggest objection to papering first is that you are always too skimpy with glue so none will squeeze out and get on the paper. I try to use the amount of glue that fills the joint, so some will squeeze out in every joint and be wiped up. But wiping glue off of wallpaper leaves a streak, so the temptation is to go skimpy, and the joints aren't as strong.

Second, I can always tell a house that was pre-papered because the corners show a void instead of being continuous (see the slideshows about how to crowd the papers together in the corner... you can't do that with pre-papered walls).

Third, I have had to replace paper too often that has gotten damaged by glue or tape during construction... that wastes time and paper (\$) and can make it so you are left deciding whether to replace a damaged paper or letting it slide because you don't have any more of that pattern and you'll have to order it and that takes too much time (running out but then needing another piece is a distressing moment).

Finally, I don't find pre-papering to be faster. By the time I have done all of the extra planning that getting the papers in the right place requires, I have used up any potential advantage. I have great big blacksmith's hands, and papering in a finished house is easy for me.

**A: Getting Started:** Do these things before the house assembly

**Square the corners** of the window, door, and stair holes with a utility knife - each cutout has a rounded corner left over from the tool that made it. Make two cuts in each corner from the outside (one from each direction), then cut from each direction on the inside to cut away the rounding in the corner so the window, door, or stairs will fit.

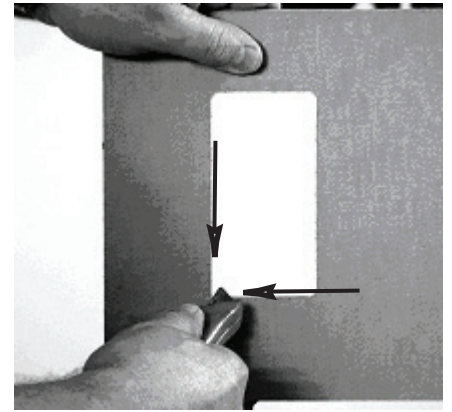

A **Double-Cut Coarse file** is easier for many people to use when squaring the corners. Make several strokes from each direction in each corner and test the Window or Door to see how it fits.



**Pre-Assembly: Assemble the Window Frames before painting**

**Window Frame Assembly:**

1. Test assemble (*no glue*) a window set Practice holding the frame pieces face-down on a piece of cardboard and putting on the rubber band (a scrap of tape at each corner helps). In the illustrations, the hands are holding the frame parts down, not squeezing together. When you can get the rubber band on every time without pieces flying, then you are ready for glue.

2. Glue and rubber band together the window frames. Make sure the frames are square as the glue dries.

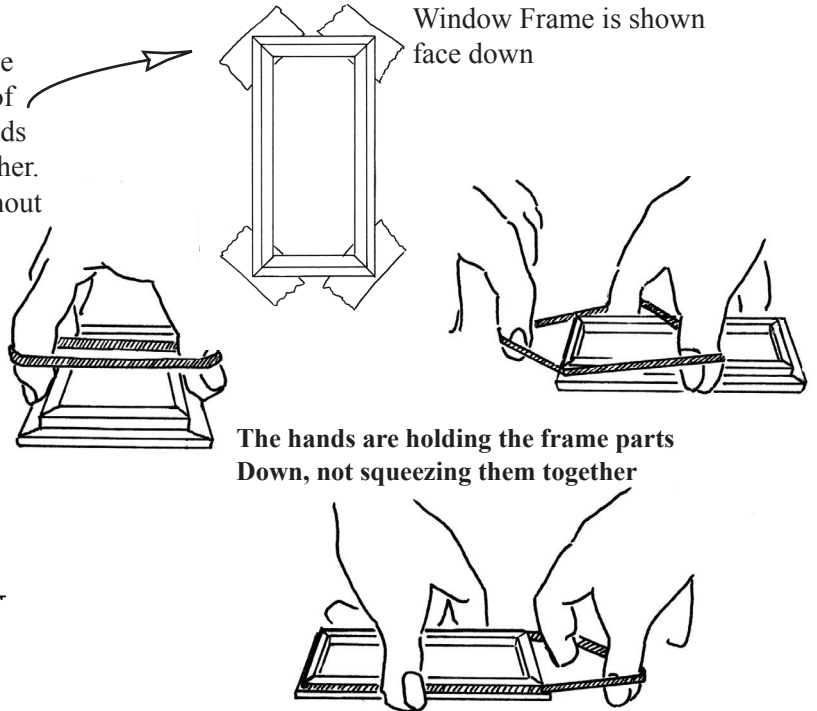
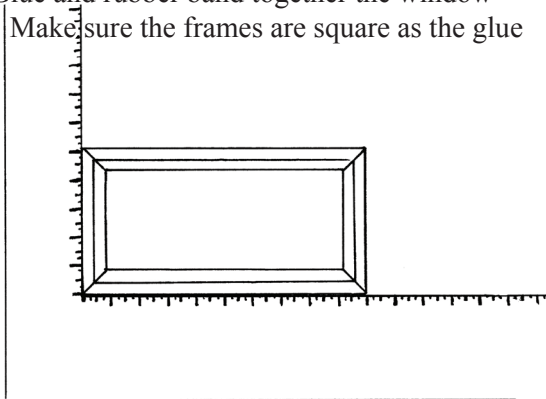

Window Frame is shown face down

The hands are holding the frame parts Down, not squeezing them together

**Pre-Assembly: Assemble the Foundation before painting**

**Foundation Assembly:**

1. Glue and tape together the Farmhouse Foundation (3/4" tall) or the Alison Foundation (1 1/4" tall) depending on what house you have.

2. Without glue, put the Base Floor on the Foundation set lined up on 3 edges to check that the Foundation set is square while the glue dries and that you have the overlaps in the right direction.

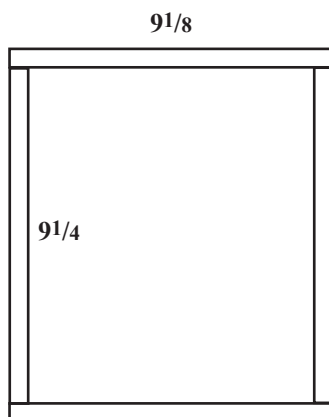

JM33 Foundation next to a Farmhouse Jr.

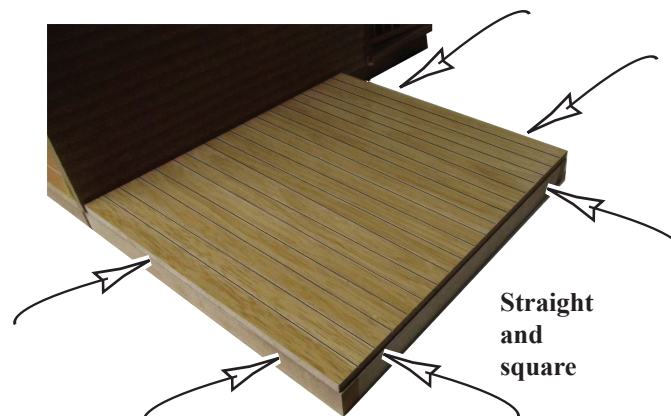

Straight and square

**Painting:** [www.RealGoodToys.help](http://www.RealGoodToys.help) has painting and sanding videos

**A word about primer:** Primer is designed to help paint stick to an impervious surface or to join layers of dissimilar paints. In *this* application, the first coat of paint soaks right into the wood and fills the grain - you *could* do that with primer, but its job of being an interface between different materials doesn't apply here. In *this* application, primer just adds steps and expense. I don't use it here and don't suggest it.

**Paint the parts** the first coat. The first coat mostly soaks into the wood, filling and reinforcing the grain so the sanding step clips off the fibers and leaves the surface smooth. Resist sanding before painting - it will leave the surface fuzzy and make a smooth finish harder to achieve. The quality of your final finish is dependent on the quality of the sanding after the first coat. Do not go back to re-paint just because the paint has soaked in. Just a bit of paint left on the surface tells you you have put on enough to saturate the grain, which is the right amount. More paint than that will only make sanding harder.

**Glue doesn't stick to paint.** Avoid painting edges, grooves, and areas that will be glued.

**Paint** the walls on both faces. Paint the Mid Floor on the bottom face.  
Paint the Trim on one face and both edges.

**Sand everything.** Sand until the paint is smooth and "soft" feeling, transparent, and some of the wood is showing through. Sand the Clapboard one-clapboard-surface-at-a-time. Fold the sandpaper and sand back and forth until the surface of that board is smooth and transparent; then move on to the next board. Fold the sandpaper as needed to keep it fresh.

**Paint the second coat.** The Second coat for the outside of the Walls may be done after assembly of the housebody (that's what I do). The second coat goes on smooth and creamy with enough paint on the brush so it is quiet while you are brushing the paint out, but not enough to leave puddles or drips.

**Clean the edges and grooves** before assembly. A little paint always builds-out the corner of an edge or groove and will make assembly harder and the glue joint less strong. Test the Floor, Liner, and Back in their grooves to see that they fit well.

Do not stack painted parts - even when they feel dry they will stick and damage each other. Keep them spread out or separate them with waxed paper.

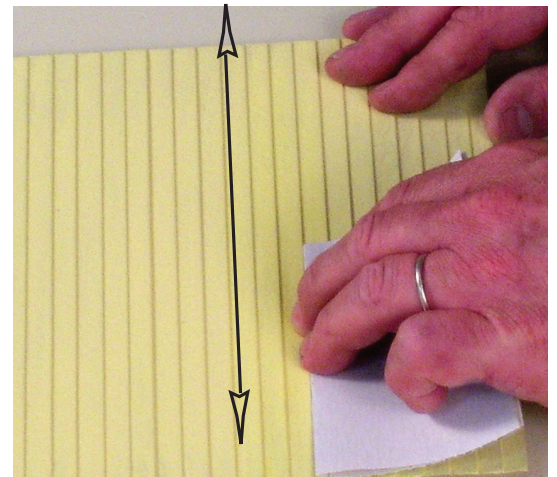
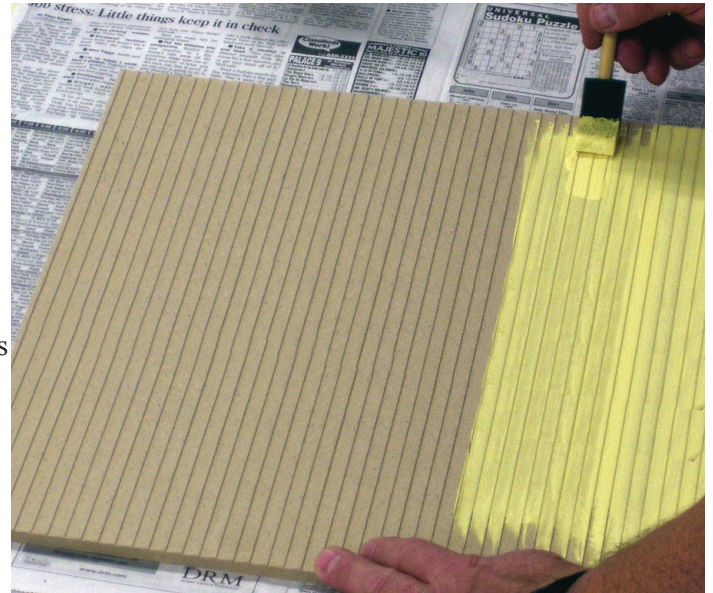

Cleaning a groove with a Cabinet Scraper



the back edge

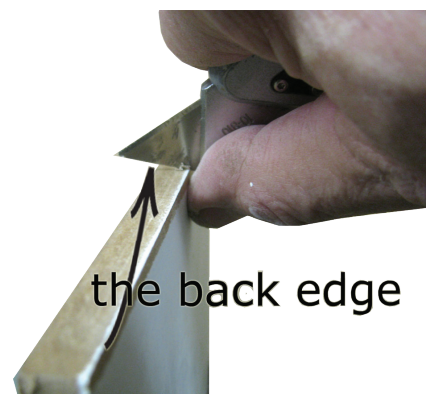

Cleaning an edge with the back of a utility knife blade

Q: How can I prevent glue from getting on the floor after I press it into the groove?

A: Do not skimp on the glue... a little squeezing out tells you that there's enough glue in the joint. Clean up the squeezings with a damp rag followed by a dry rag, and the little bit that remains down in the grooves will shrink back as it dries, and will not be visible.

This issue is one of the reasons it is important to pre-finish the floors before assembly. I know, the finish tries to bead up when you first put it on and it is 'paint-can-runny', but just keep rubbing it out as it loses its excess moisture and starts to get tacky, and that first coat will eventually behave itself and lay down properly. I like to do the first-coat-rub-out with a crumple of brown paper bag so I can rub vigorously and 'de-shine' the print flooring, but other builders report success with just brushing and brushing until the moisture level gets right. After the finish is dry, do a very light de-shine with a non-woven abrasive pad (like 'Scotch Brite', the green pad you use in the kitchen for stainless steel pots... a used one is just right), and then put on a second coat of finish.

- 1. **Finish the Floors:** The floors need finishing to protect them from damage by tape being removed, by paint or glue, or by normal wear-and-tear during assembly. Wipe off the first coat and, when it is dry, de-shine the surface with a non-woven pad (also called "synthetic steel wool") or a crumple of brown paper bag; then apply more coats.

**Addition Body Assembly**

**Note from our Assembly Pro:** This addition should be built in place alongside the finished dollhouse, dry fit parts before final gluing, and let the glue dry with the addition tight to the house. This is the only way to get a perfect fit.

Carefully check the table you will be working on for FLAT! A house built on a sagging table will not fit together properly.

Continue to step 9 without stopping

- 2. Select the Middle Floor. Without glue, test the Floor panel to check the fit and orientation (Illustration #2).

**Illustration #2**  
Check the Fit of the Middle Floor and Side Panel

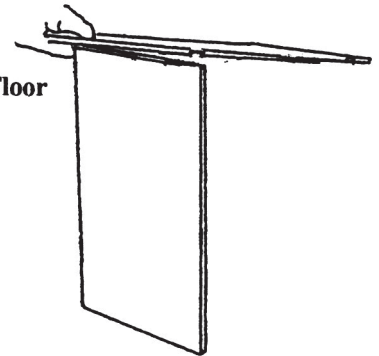

- 3. Spread glue in the grooves of the Side panel (Illustration #3). Use plenty of glue and spread it lightly with your finger to keep it from dripping (if the glue is too runny, wait a bit for it to tack).

**Illustration #3**  
Spread Glue in the Grooves

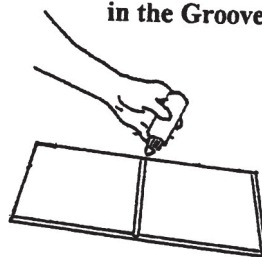

Now is a great time for an extra pair of hands.

- 4. Stand the Middle Floor on end (check the orientation again) and set the Side panel over the Floor in the middle groove.
- 5. Adjust and check all the parts. The Floor must be flush at the back edge of the Side panel ("flush" means 'forming a continuous, unbroken surface'). The Floor overhangs the front of the Side panel by 1/8" (Illustration #4).

**Illustration #4**  
The Floors overhang the Side Panel 1/8" in the Front

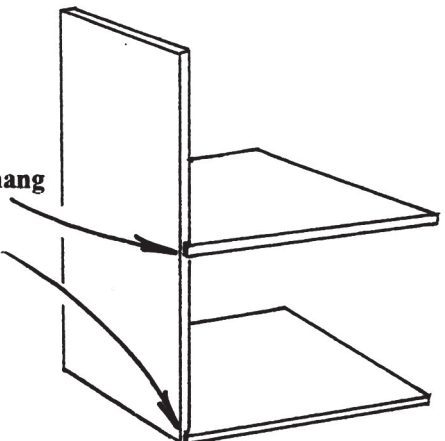

- 6. Set the Base Floor (woodgrain side up) into the Base Floor Groove. Make extra-sure that the Base Floor is pressed to the top-edge of the groove.

**Can I do it differently?** *Yes you can - it's your house!*

The information on these pages is offered as “best practices” advice, and it is what we do when we build this addition. But if you are customizing or have something else in mind, test-ahead to make sure your planning includes *everything!*

**Assembly details:**

Photos support the descriptions but do not replace them

**Note:** Many of these photos are of un-painted parts, but you should have painted these parts at least one-coat already, and have sanded thoroughly.

Use enough glue so some squeezes out of every joint.  
Keep a damp rag and a dry rag handy to clean up excess.



**Taping:** Use enough tape so you can stick it down and still have length enough to stretch the tape on both sides of the joint... then rub the tape down for good adhesion.

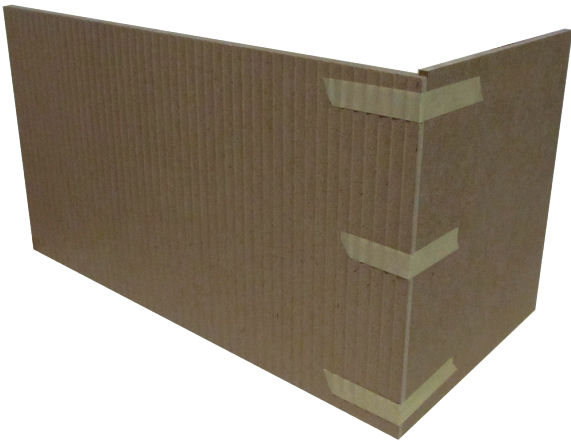

The back is down, the Floors stick out 1/8" in front (up).

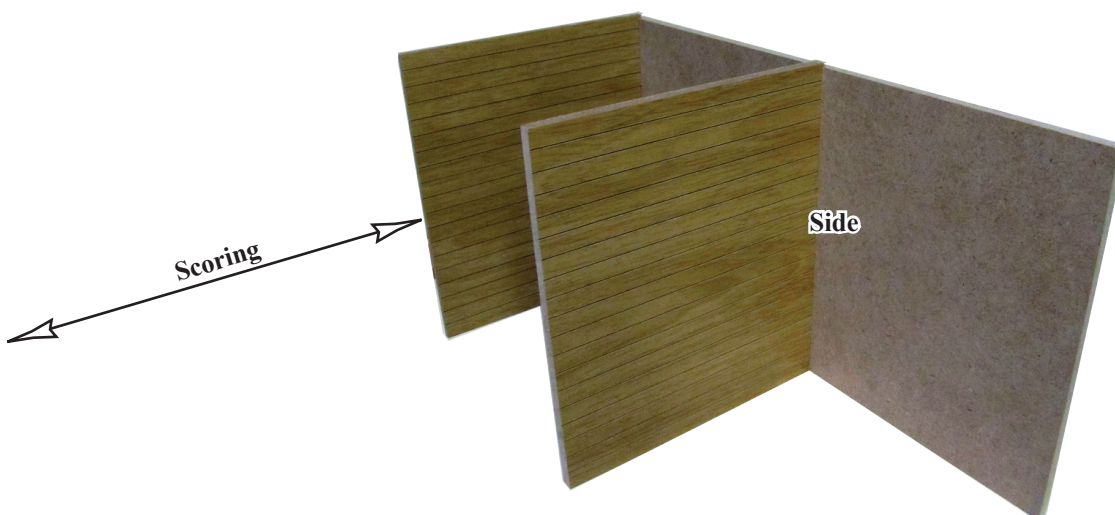
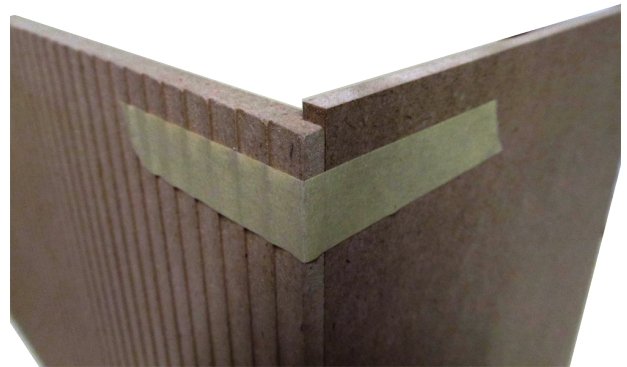

- 7. Glue and tape the 9" tall Liner between the Floors opposite the side, flush on the outside with the ends of the Floors and flush at the back edge.
- 8. Lay the Addition Body down on its BACK. Without glue test the Front in place on the addition, flush with the Side panel at the top and bottom.
- 9. Spread glue in the grooves of the Front panel and on the front edge of the Side panel. Set the Front panel into position on the addition (Illustration #5).

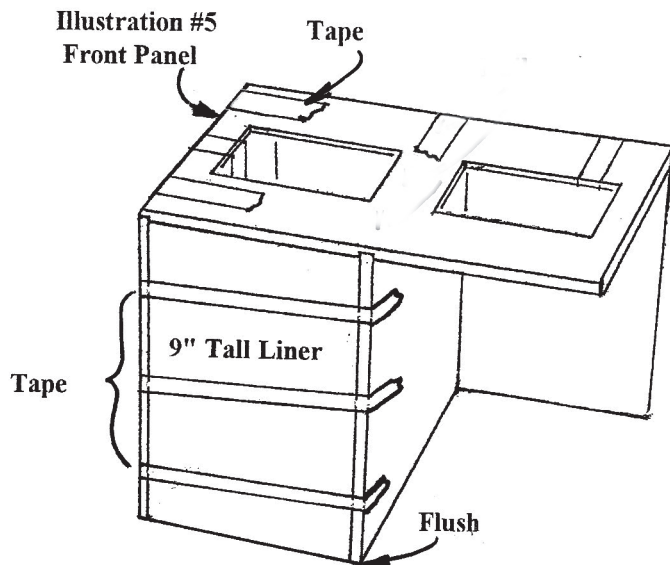

Carefully tape in many places along the bottom edge making sure the Base Floor is tight to the top edge of the groove.

Line up the side edge; make sure the front is flush with the ends of the floors all the way from the bottom to the top (This is the operation that straightens the addition). Tape the Front securely to the Side.

**Review:** Make sure all parts are in place and all the joints are tight.

- The Base Floor is tight to the groove-top.
- The Front is flush with the ends of the floors
- The addition is straight.

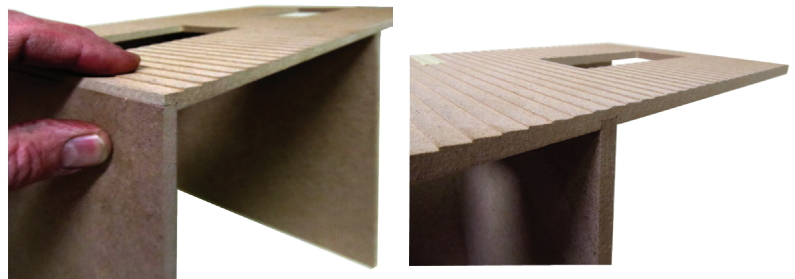
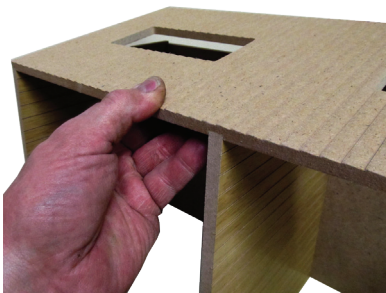

The Floors line up on the open end

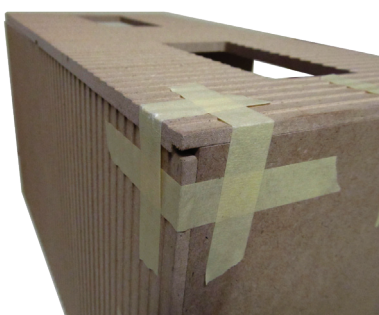

A well-taped corner won't slip

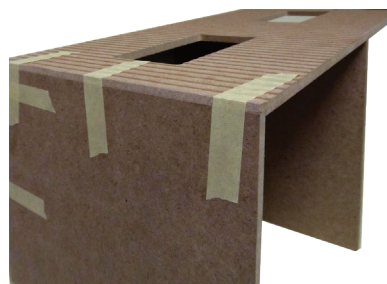

Tape all along the Base

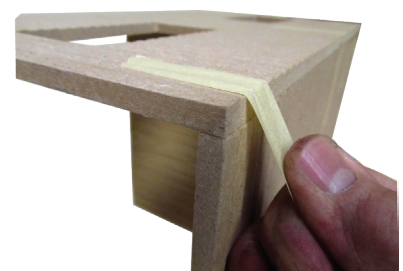

Tape solidly



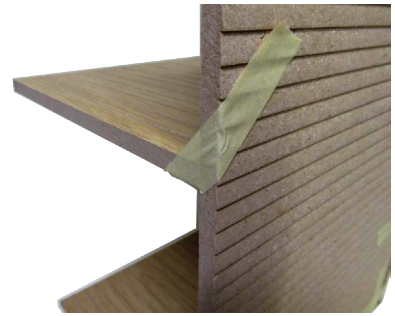
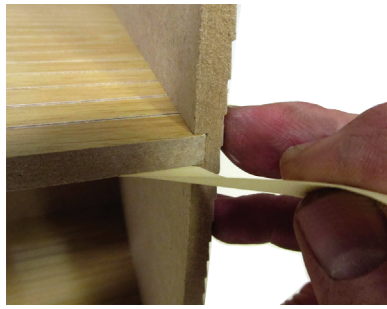
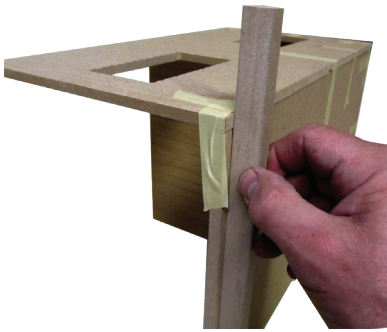

Avoid taping to the printed surface of the Floors

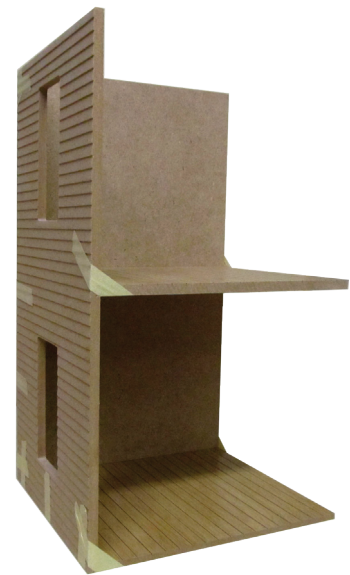
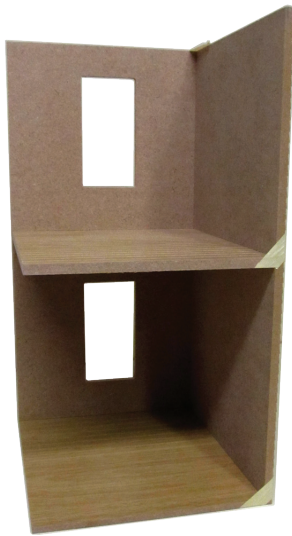

Make sure the Base is tight to the top of the groove. Photos A-C show a handy technique if it is necessary for an extra push to hold the Floor tight.

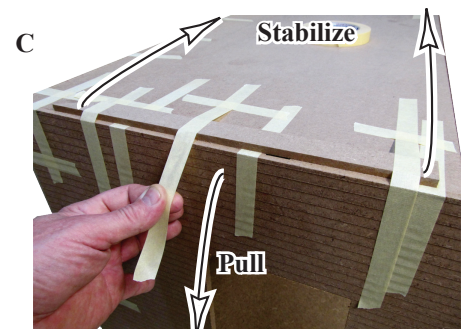

Tape the Trim so it won't slip, Press the looseness tight, then pull a strap of tape firmly to hold it there - rub it down.

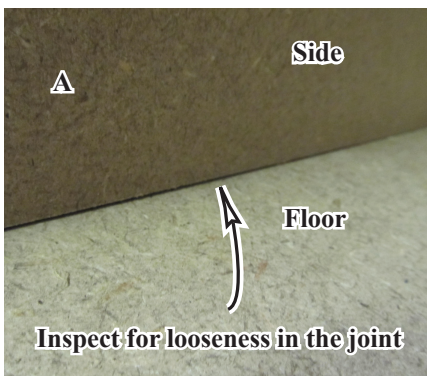

Inspect for looseness in the joint

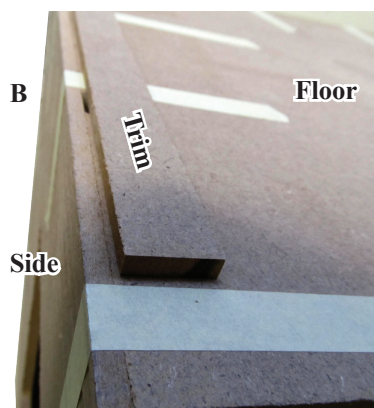

An un-used piece sitting on the Floor only, not overlapping the Side

Let the glue dry.

Note: Many of these photos are of a temporary build (tape only) and the tape stayed on throughout the build, but you should take your tape off when the glue is dry.

Now is a good time to finish the painting of the Walls and Foundation

Steps 10 and 11: If you haven't assembled your foundation, go back to page 4 and do so now.

12. Glue the foundation assembly to the house foundation, flush at the back edge.

see the photo on page 11

13. Glue and tape the addition to the housebody and addition foundation, flush at the back (Illustration #7). Let the glue dry.

14. Glue the 8 1/2" tall Liner to the house side and to the top of the Middle Floor

15. Without glue, test fit the Roof Top on the addition body, flush at the back, and up against the housebody. The Roof Top overhangs the addition evenly on the front and side (Illustration #8).

Lightly trace the perimeter of the addition on the bottom of the Roof Top. Check to make sure the addition's side and front are parallel with the side and front of the Roof Top.



Remove the Roof Top and paint the outside of the tracing now. Make sure your addition painting is done as well. Let the paint dry.

*You can skip ahead to the section for assembling the Windows (pg. 7) and come back to step 14 when the Roof Top paint is dry.*

16. Glue and tape the Roof Top in place. Add weights and tape as the glue dries for a tight fit.

**Review:** Check the fit of all the parts and make sure all the joints are tight. Make sure the Floors and Roof Top are straight and flat. Use tape and weights as necessary to get all the joints tight as the glue dries.

Illustration #7  
Glue the Addition Body to the House and the Addition Foundation

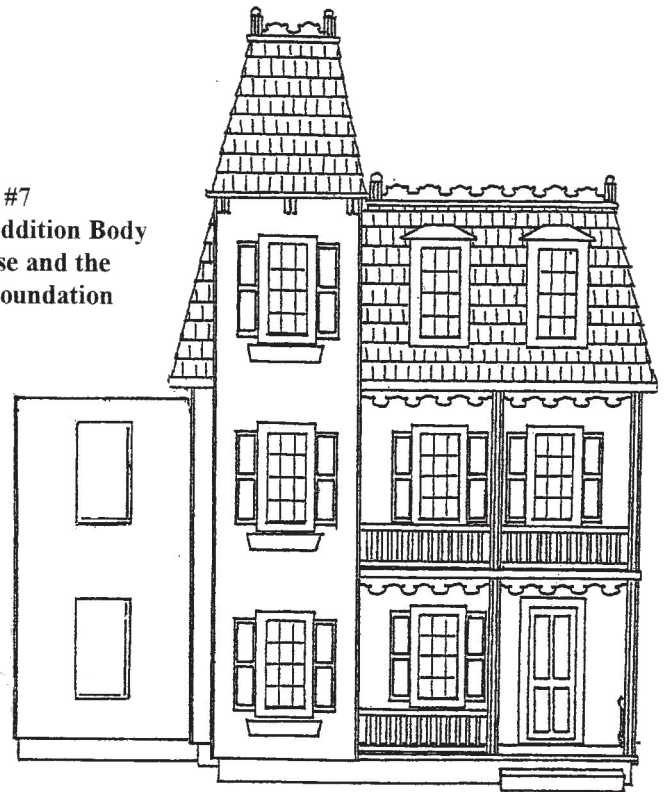
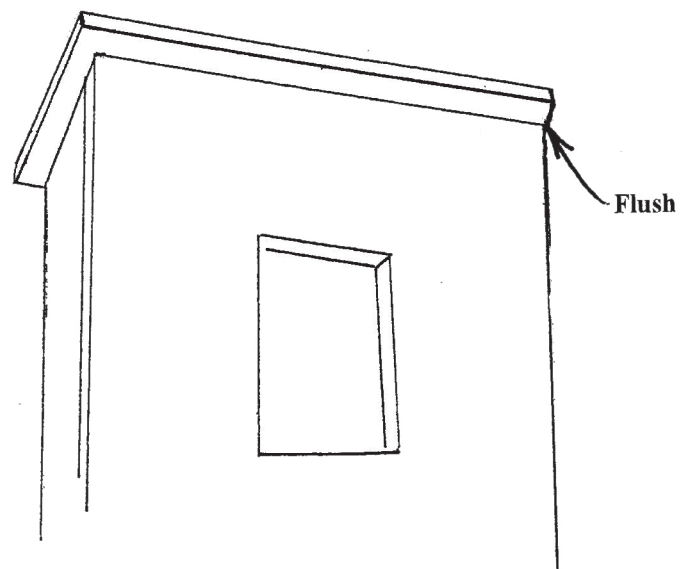
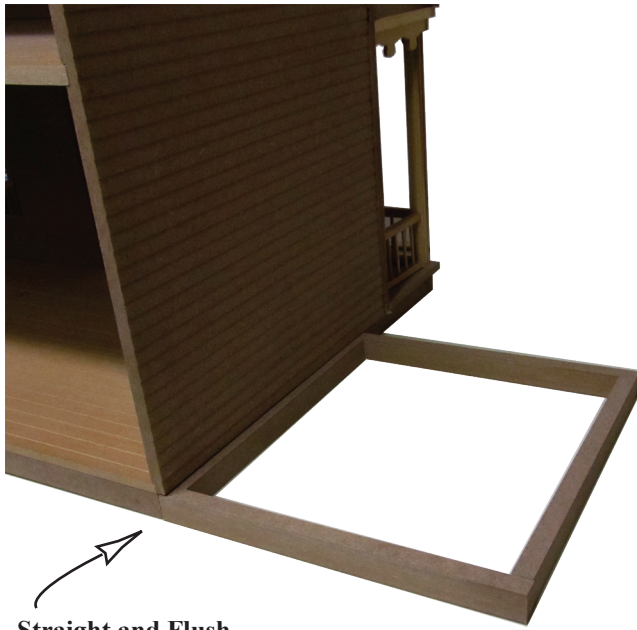
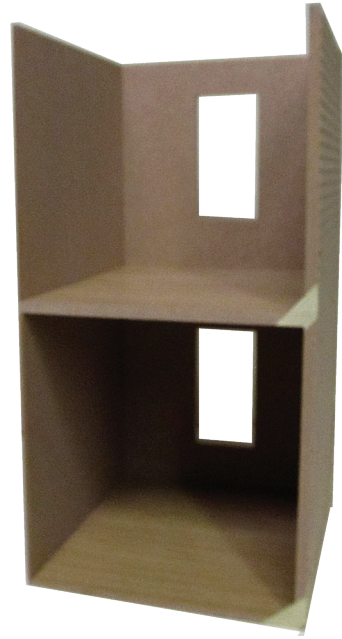

Illustration #8  
Glue and Tape the Roof Top in place





Straight and Flush



Now is when you need a flat table the most!



**Exterior Painting:**

The addition Walls, Foundation, and Roof Top should already be painted.

Skip ahead to the proper assembly sections to decide how you would like each part finished:

- Trimstrips (
- Brackets (
- Windows (
- Shutters (
- Flower Boxes (
- Cresting (
- Fluteposts/Beads (

7/16" Trimstrips

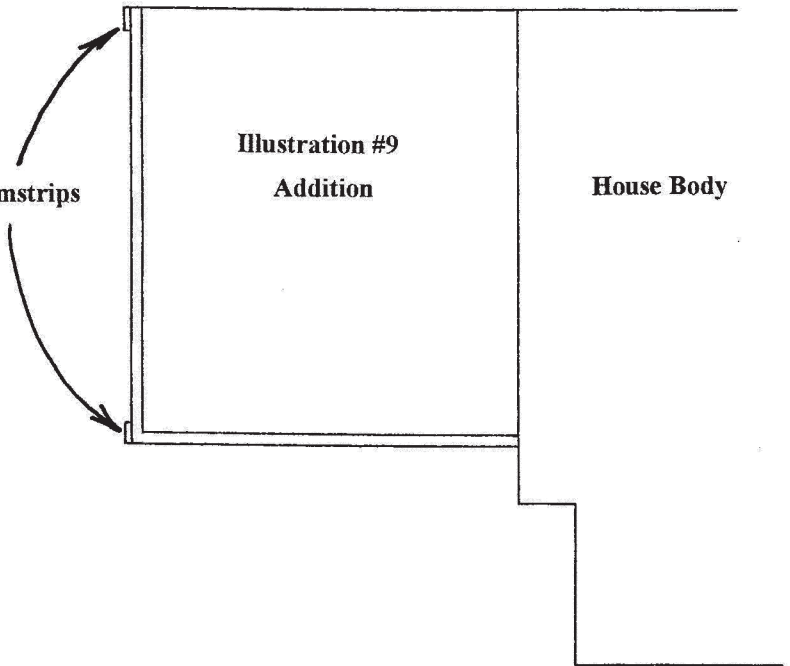

**7/16" Trimstrips:**

- 17. Glue the painted Trimstrips on the front and back edges of the side (Illustration #9).

**Brackets:**

- 18. Paint the Brackets before attaching them. Tip the house onto its back to lay out the three pairs of Brackets across the Front of the addition (Illustration #10). Space the Brackets in each pair about 1/16" apart. When the Bracket spacing is right, remove the Brackets one at a time, and glue that Bracket on. etc. until all the Brackets are glued on. Check that all the spacing is still the way you like it. Let the glue dry.

Repeat for the side Brackets (Illustration 11).

Illustration #10

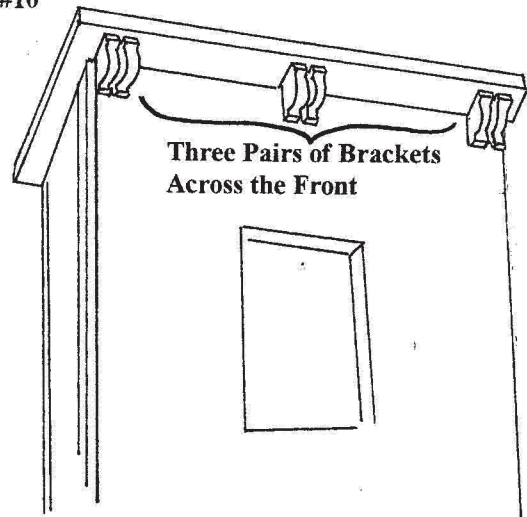
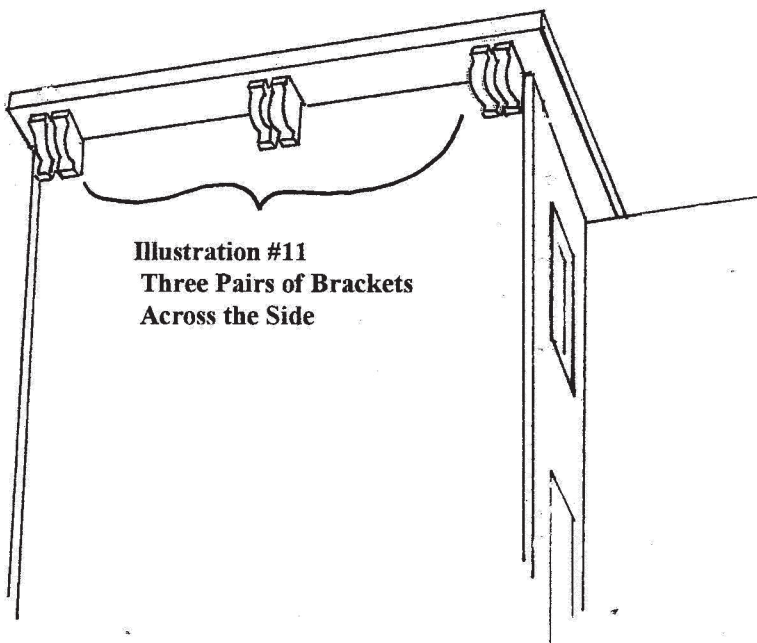

Illustration #11  
Three Pairs of Brackets  
Across the Side



19. Check the fit of the windows in the openings. Make sure the windows can sit level with the house. Trim the corners of the openings square if necessary for a good fit.

20. Paint the Shutter parts on both faces. Without glue, adjust the spacing of the Shutter Panels on the Shutter Cores. Remove the Shutter Panel, put a scant line of glue on each edge of the back surface, then replace the Shutter Panel. Too much glue will make the panel curl.

21. Glue the windows and the Shutters in place only after everything on the outside is painted.

Attach the exterior window frames as part of the exterior finishing. The Panes and Interior frames are installed after the interior finishing is done (wallpaper, paint, etc.), set the window plexi into the window cutout and glue the interior window frame in place.

Interior Window Frame

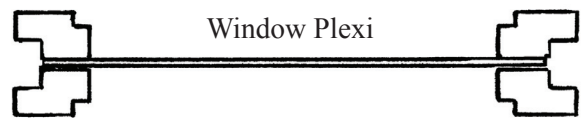

Exterior Window Frame

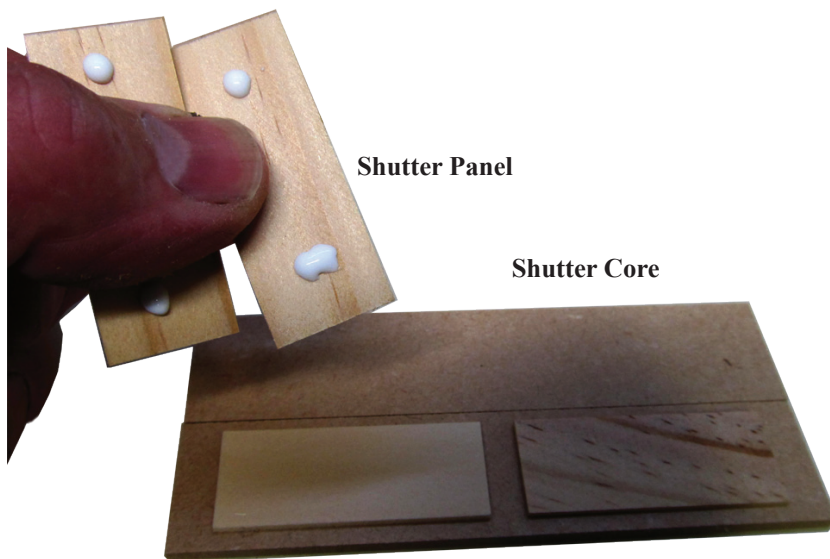
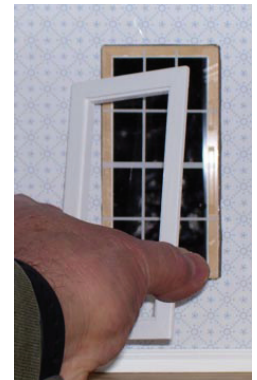

Shutter Panel

Shutter Core

Shutter centered up-and-down

Flower Box centered side-to-side

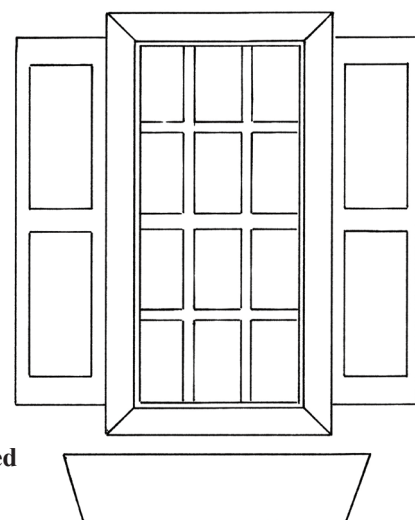

**Finish the Outside**

**Roof Top Cresting:**

- 22. Lay out and cut the Cresting set.  
Cut the Cresting with a fine toothed saw (such as an X-acto™ razor saw or a hack saw). Line up the Cresting with the pattern, and mark the cuts with a pencil... there is enough Cresting to get both cuts from the material supplied, but a wrong cut can leave you with two short pieces when you need one long piece. Plan ahead(!), then make your cut.
  - Cut one piece of Cresting 7<sup>3</sup>/<sub>4</sub>" long centered on the 7<sup>3</sup>/<sub>4</sub>" Cresting pattern.
  - Cut one piece of Cresting 9<sup>15</sup>/<sub>16</sub>" long centered on the 9<sup>15</sup>/<sub>16</sub>" Cresting pattern.

Note from our Assembly Pro: Paint the Cresting, the Fluteposts, and the Beads before assembly.

- 23. Assemble the Flutepost/Bead sets (Illustration #16).
- 24. Without glue, set up the Cresting set with Posts at the corners (Illustration #17). When the position is the way you like it, remove one piece at a time, and glue that piece on. etc.

**Finish the Inside...Plan Ahead!**

**Interior Finishing:**

Our pro finishes the interior of a few houses and additions each year. Here's the order that he follows for tackling the interior finishing:

- Electrical wiring (he only uses **tape** style)
- Wallpaper (use "Yes" brand paper)
- Carpeting
- Molding and trim

see: [www.RealGoodToys.help](http://www.RealGoodToys.help) for details

Congratulations  
You have finished  
the Addition  
part of your project....

**Enjoy the rest !**

**Special Feature: Cresting is Pre-Cut**

