

# ***'SpeedSafe' Electronic Speed Limiter for Kubota RTV-X900 from 2014***



Applicable models for this product:  
Kubota RTV-X900

The 'SpeedSafe' speed limiter is an electronic speed limiter for fitment to RTV's.

It is a 'stand-alone' device or may be added to an existing 'QuadCruise' cruise control installation. A cruise control cannot be added to an existing speed limiter installation without replacing most of the parts.

The 'SpeedSafe' speed limiter can be set to any speed desired. The 'SpeedSafe' speed limiter allows full use of the available power on the ATV up to the limiting speed. The limiting speed is normally set to 25kph (15mph), but can be set to any speed the owner/manager desires.

Only 'Standard' configuration is available on the RTV-X900. In order to prevent an operator tampering with the speed limiter, tags are provided in the kit to fit to critical connections.

When the vehicle reaches the limiting speed, the speed limiter causes the engine to misfire, progressively cutting engine power by controlling the operation of the fuel injector. . There are several different operating modes available.

When 'Soft Cut Mode' is selected, at the limiting speed the engine develops a slight but rapid misfire. If the operator tries to go faster by applying more throttle, the speed limiter makes the misfire worse as speed increases. The 'range' of the speed variation from slight misfire to severe misfire is selectable (0.5kph to 8kph in several steps) as well as the 'rate' of the misfire (2, 4 or 6 'misfires' per second). The misfire is so severe at the highest cut rate, the vehicle cannot exceed the maximum speed. If a very 'firm' limit is desired, a low speed range (0.5kph) would be selected, if a 'soft' limit is desired a high speed range (8kph) would be selected. The 'rate' of the misfire also effects the 'feel' of the limiter, but not the operation. 2 misfires per second is very rough, 6 is smoother.

When 'Hard Cut Mode' is selected, at the limiting speed the engine is cut several times a second (4 to 5 times per second). The severity of the cut or misfire is selectable to produce a moderate 'roughness' in the misfire to a more severe misfire. If the limiting speed is exceeded by 2kph, the engine is cut completely until the speed drops below the 2kph 'buffer'.

'Penalty Mode' can also be selected when using either soft or hard cut modes. If the operator persists in running on the limit (causing misfire) for more than 5 seconds, the limiting speed is reduced progressively and is held for a period of time. If the operator keeps the speed below the limiting speed, after the time has elapsed, the original limiting speed is restored. The amount of the speed reduction and the penalty time period are both selectable.

The following provides a brief description of the component locations of the 'SpeedSafe' electronic speed limiter.

Current draw is approximately 0.020 amp (0.28 watts).

Installed weight of the speed limiter by itself (not including cruise control parts) is approximately 0.5kg (depending on model).

Refer to the line drawing on the back of this sheet to identify the component numbers in the text.

The **Computer (1)** is installed in the front compartment.



The **Setup Control Switch (2)** is hand held for setup of the speed limiter, and is then removed from the vehicle. This remains fitted to the vehicle when the cruise control is fitted, but there is a specific set of instructions that must be followed so that the speed limiter setup cannot be altered by the operator accidentally or intentionally.



The **Wiring Harness (3)** is dedicated to the vehicle. Power and speed signal for the speed limiter is sourced from the vehicles instrument cluster connectors. Terminals are backed out of the connectors and matching terminal on the speed limiter harness are connected to the vehicle's plugs. Ground is sourced from the negative terminal of the battery.

The **Relay Harness (4)** is connected to the engine fuel stop solenoid cut the engine, also using the same method as the power and speed signal connection. This harness is also connected to the main speed limiter harness.

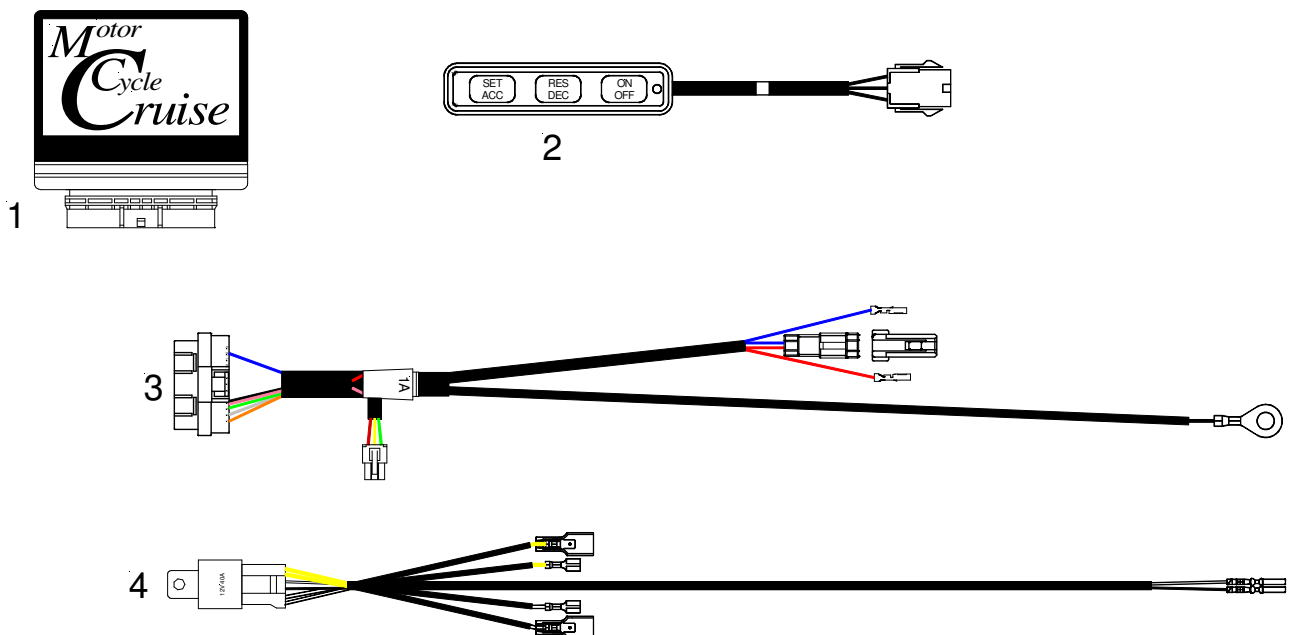

## ***MotorCycle Cruise Controls***

**6 Kingston Street  
Mount Waverley VIC 3149  
AUSTRALIA**

**Web Site:** <http://www.mccruise.com>

**International:** **Phone** (International Access Code) 61 3 9808 2804

**Fax** (International Access Code) 61 3 9808 2445

**Australia:** **Phone** (03) 9808 2804

**Fax** (03) 9808 2445

**E-mail:** [sales@mccruise.com](mailto:sales@mccruise.com)

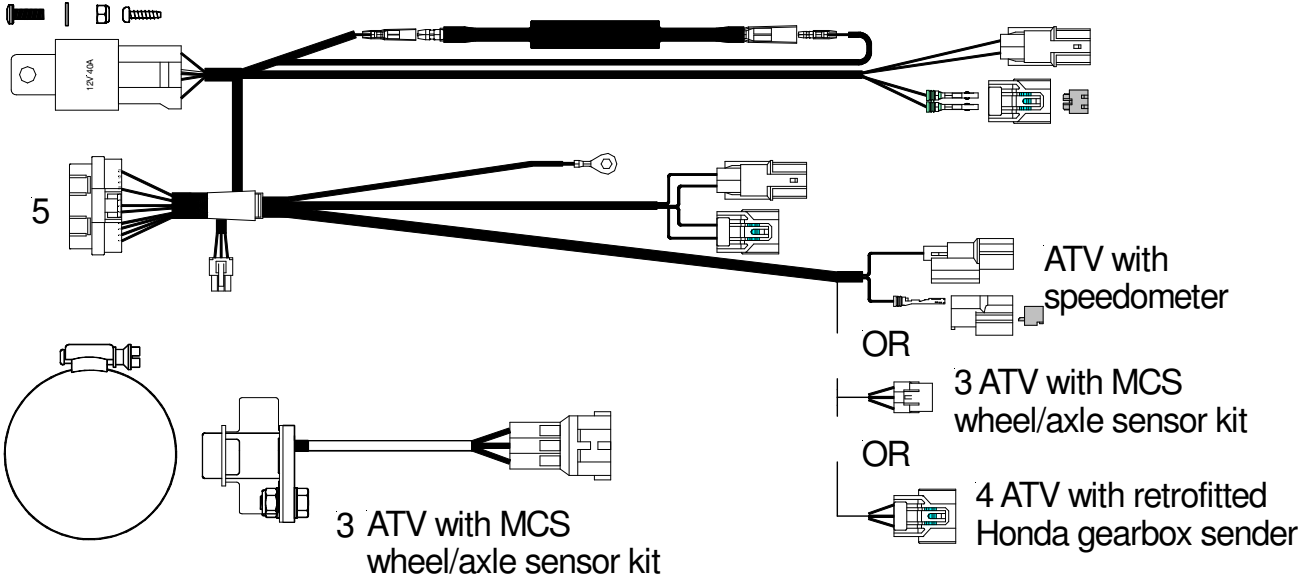
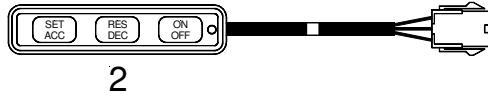
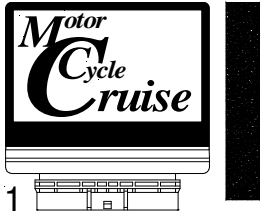

## ***MotorCycle Cruise Controls***

**6 Kingston Street  
Mount Waverley VIC 3149  
AUSTRALIA**

**Web Site:** <http://www.mccruise.com>

**International:** **Phone** (International Access Code) 61 3 9808 2804

**Fax** (International Access Code) 61 3 9808 2445

**Australia:** **Phone** (03) 9808 2804

**Fax** (03) 9808 2445

**E-mail:** [sales@mccruise.com](mailto:sales@mccruise.com)