

Electronic Cruise Control for CF Moto 650 MT



The following provides a brief description of the power consumption and component locations of the MotorCycle Setup electronic cruise control.

Installed weight of the cruise control is approximately 2.2kg.

Current draw while the cruise is switched on, but not engaged, is approximately 0.2 amp (2.5 watts). Current draw while the cruise is engaged is nominally 0.50~1 amp (6~12 Watts).

By comparison, a head light bulb typically draws about 4 amps (55 Watts), and a taillight bulb (running light) draws about 0.4 amp (5 Watts).

Refer to the line drawing at the end of this document to identify the components from the numbers in the text.

The **Computer (1)** is fitted under the passenger seat.

There are three possible mounting locations for the **Electric Throttle Servo (2)**. The first two have the servo mounted on the left side of the bike on the crash bars, either above or below the crash bar frame tube as shown in the photos below.



Servo mounted above the crash bar.



Servo mounted below the crash bar.



The cruise control kit may also be ordered with the Rear Mounting Servo Kit. This kit provides alternate mounting hardware to mount the servo above the right rear footrest mount.



The **CIU or Cable Interface Unit (3)** is mounted on the right side of the motor, next to the right rear corner of the cylinder head. This photo shows the CIU with the left side crash bar mounted throttle servo. The servo cable is hidden behind the bike's panels.

The CIU has a new **cable (4)** running from the CIU to the bike's throttle bodies.



When the **Electric Throttle Servo (left arrow)** is mounted in the right rear location, the servo cable is visible running from the **Throttle Servo (left arrow)** to the **CIU (right arrow)** in the photo below left. The photo below right shows the CIU with the servo cable coming in from the left.



MotorCycle Cruise Controls

Unit 13, 137-145 Rooks Road

Nunawading VIC 3131

AUSTRALIA

Web Site:

<http://www.mccruise.com>

International:

Phone (International Access Code) 61 3 9808 2804

Australia:

Phone (03) 9808 2804

E-mail:

sales@mccruise.com

The standard **Control Switch (5a)** mounts above the handlebar on the left side on the mirror mount. This switch has backlit buttons for night use, and an indicator light for power (ON-OFF) and engage indication.



The optional **Control Switch (5b)** is the same switch as above, and it is mounted in the same way as above, but the switch is offset further to the left, so it is closer to the handlebar grip.



The New Slim **Control Switch (5c)** mounts on the handlebar on the left side between the bikes' switch block and the clutch lever mounting clamp. This switch also has backlit buttons for night use, and an indicator light for power (ON-OFF) and engage indication.

The new switch is a no cost option, either switch may be selected when purchasing the cruise control.



MotorCycle Cruise Controls

Unit 13, 137-145 Rooks Road

Nunawading VIC 3131

AUSTRALIA

Web Site:

<http://www.mccruise.com>

International:

Phone (International Access Code) 61 3 9808 2804

Australia:

Phone (03) 9808 2804

E-mail:

sales@mccruise.com

The **Wiring Harness (6)** has the same type of plugs or terminals that are already used on the motorcycle. Power for the cruise control and brake sensing is taken off the brake light switches by unplugging the rear brake light switch. Matching connectors on the cruise control loom are plugged in to the switch and the bike's loom. Speed sensing is taken from the bike's speed signal to the speedometer. Tach (engine speed) sensing is detected from the bike's ignition circuit. This is used to disengage the cruise if the clutch is operated. The bike's clutch switch is also connected to the cruise control to disengage the cruise control. The cruise control is grounded on the negative terminal of the battery. All these connections are "Plug & Play", no cutting of wires or splicing is required, but terminals on the motorcycle do have to be backed out of housings (connector plugs) for two connections. See over the page for details of the type of terminal extractor tools you will need to perform this operation on these connections.

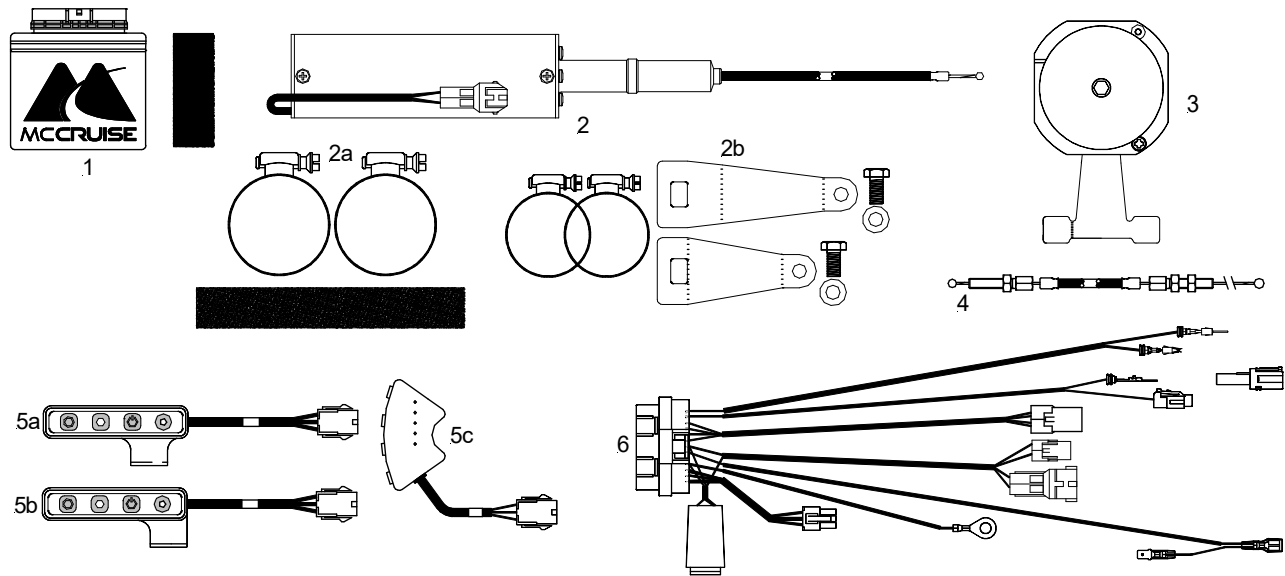

NOTE: - The installation of the cruise control requires that small and delicate electrical terminals be backed out of a connector housing. Suitable tools to do this are available to be ordered with the cruise control if the installer does not have such tools already. Backing out these terminals without suitable tools is almost impossible.

The 11 piece set we supply in the kit as an optional purchase seems to be generally available on Ali-Express and EBay for a few dollars, by searching for the part number ZZLJ7596 or by searching for 'terminal extractor set'.

The set in the photo is a typical 11-piece extractor set. The tool that we found fitted the best is the one arrowed with 4.5mm wide blade with two prongs. Whoever marked up this photo with the sizes of the blades got it VERY wrong, but the 4.5mm twin prong blade is the correct one for the connectors on this bike.

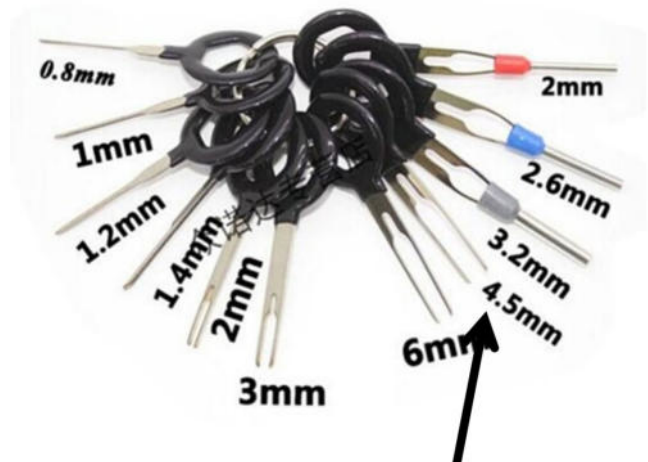

MotorCycle Cruise Controls

Unit 13, 137-145 Rooks Road
Nunawading VIC 3131
AUSTRALIA

Web Site:

<http://www.mccruise.com>

International:

Phone (International Access Code) 61 3 9808 2804

Australia:

Phone (03) 9808 2804

E-mail:

sales@mccruise.com