

TRITON/DUAL

Accessories

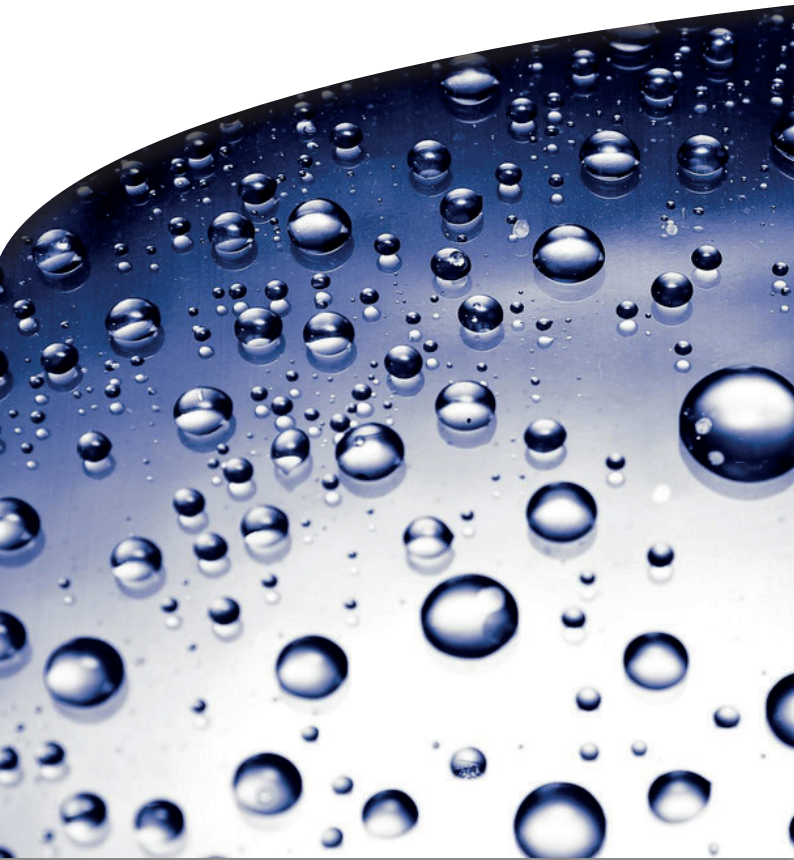

WINCARE
N o r d i c

Triton/Dual: powered, height adjustable,
tilt-in-space shower commode chair

Triton/Dual accessories



	Product	Item number
	Triton/Dual	044-00050
	Triton/Dual with emergency stop and lowering	044-00051
	Accessories	
1	Headrest (flexible)	047-10300
2	Headrest (size S)	047-10301
3	Swing-away torso support w. PU-padding	047-00360
4	PU toilet seat with round hole	047-00271
5	PU cover for toilet seat with round hole	047-10317
6	PU cover for toilet seat (for factory mounted toilet seat)	047-00266
7	Anti-pressure pillow	047-00267
8	Wheel with direction lock (green)	047-10316
9	Elevating leg rest (set)	047-00606
10	Torso-/Hip-/Leg Belt	047-00607
11	Amputation leg rest: 1) Left : 047-00361 / 2) Right : 047-00362	047-00361 / 047-00362
12	Calf strap for footrest	047-00350
13	Crossbar between the armrests	047-00359
14	Wide arm rest (+50 mm on each side)	047-10302
15	PU backrest	047-10303
16	Plastic bedpan (compatible with factory mounted bracket set)	047-00904
17	Stainless steel bedpan with lid (different bracket set - see point 18)	047-00914
18	Bracket set for stainless steel bedpan	047-00517
19	Round plastic bedpan with lid (different bracket set - see point 20)	047-00913
20	Bracket set for round plastic bedpan	047-10312

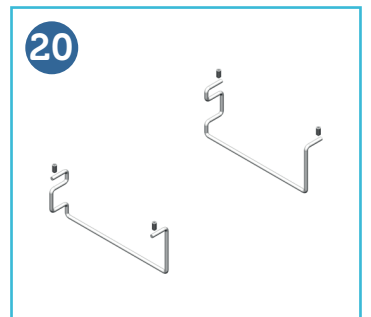
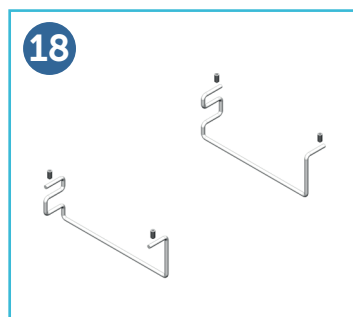
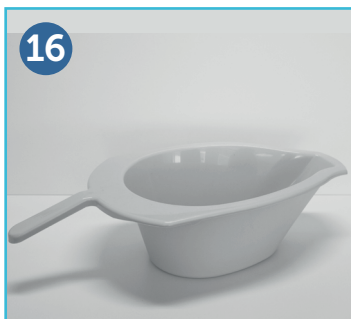

TRITON/DUAL

HIGHLIGHTS

- Powered height adjustment (Soft Start/Stop).
- Powered tilt function (+7° / -30°) and adjustable backrest for more comfort and user stability.
- IPx6W rated: Can be cleaned in washing machines up to 250 times due to LINAK IPX6 Washable DURA™ (50 washes is standard).
- Developed from the Easy-Clean principle, which means there are no small corners or edges. The chair has closed screws/joinings and fully welded steel, which prevents water from entering the pipes. It is also treated with double coating which makes it rust resistant.
- Dual Security Function (it can not be raised and tilted forward simultaneously)
- Transport function via the hand control for safe transportation of the user.
- Two programmable memory buttons on the hand control for automatic positioning and adjustment.
- Multi adjustable headrest with integrated rod which does not scratch or damage the wall behind the toilet
- Fits over all standard toilets and suitable for use in the shower

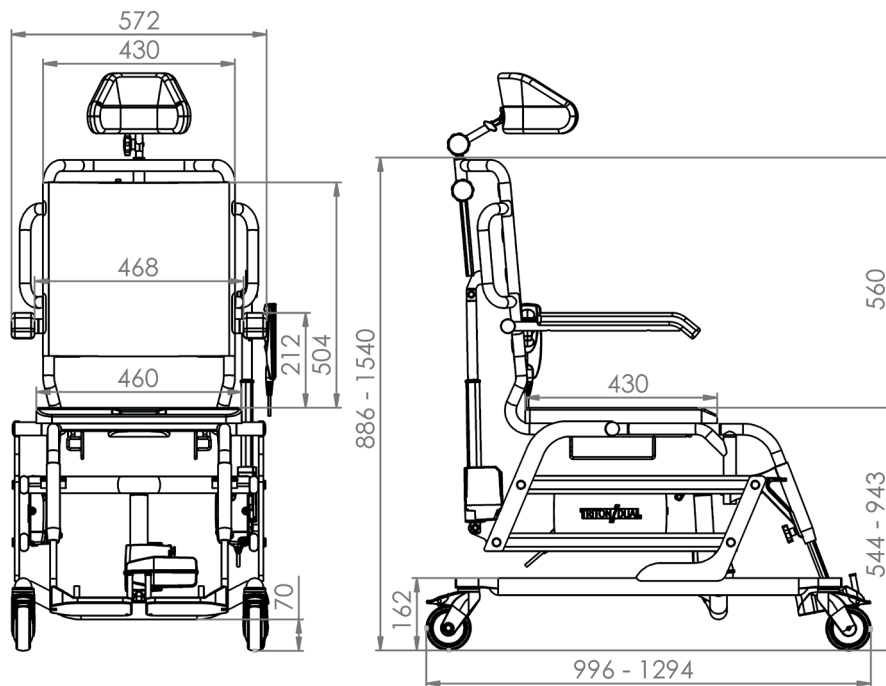

TECHNICAL SPECIFICATION

Max. user weight	150 kg/330 lbs/23,62 stone	Total height	886-1540 mm (w/o head rest)
Distance btw. armrest	468 mm	Weight	41 kg
Seat depth	430 mm	Tilt angle	+7 to -30 degrees
Seat width	460 mm	IP class	IPx6W
Seat height	544-943 mm	Charging time	6 hours
Total width	572 mm	Battery capacity	80-100 lifting cycles
Length	996-1294 mm		

WINNOCARE
N o r d i c