

Sorrento™

Operation Manual &
Product Specification Guide



Seating Matters™



CONTENTS

- 2. **Operation manual**
- 4. **Product description**
- 6. **What is the intended use of the product?**
- 8. **Product features**
- 10. **Safety instructions**
- 13. **User guide and operating instructions**
- 17. **Accessories**
- 21. **Working environment**
- 23. **Maintenance**

OPERATION MANUAL Sorrento™

ABOUT SEATING MATTERS AND THE TIERNEY FAMILY

PLEASE TAKE TIME TO READ AND UNDERSTAND THIS INFORMATION BEFORE ENJOYING THE COMFORT OF YOUR SPECIALLY CRAFTED SEATING MATTERS CHAIR.

SEATING MATTERS design and manufacture a range of specialist chairs and other associated products for healthcare environments. The Seating Matters chairs have been designed by Martina Tierney Occupational Therapist, who worked with seating throughout her professional career. She was continually searching for seating that would help her clients but was unable to find anything that fully met their needs and so Seating Matters was established by the Tierney Family. Together with Martina and other therapists, clinicians, engineers and designers, Seating Matters have designed the world's leading range of specialist chairs for those in nursing and care environments. Martina continues to research seating to find new answers to seating challenges and educate audience throughout the world on her findings. Today we manufacture a range of adult and paediatric chairs and other items to make life more comfortable for those in need. We supply our products across the globe but have not forgotten the family ethos with which we began. We care about your comfort and wellbeing and it's our commitment to you to make your experience as satisfying as it can possibly be. If you have any questions regarding Seating Matters' service or the chair you are enjoying, we invite you to call us up direct and speak to one our team. You can reach us on +4428 777 66624 or at info@seatingmatters.com - we will be glad to hear from you.



PRODUCT DESCRIPTION

Sorrento™

TERMINOLOGIES

PATIENT: The person sitting in the chair

USER: Competent person with responsibility for the persons sitting in the chair as well as the suitability of the equipment for the Patient. The User is responsible for checking the chair for faults during the course of its use.

There are many options, accessories and alternative features available with the Seating Matters chairs. We suggest you consult your local Seating Matters provider for exact information on what the best specifications are for you and to find out what comes as standard on your chair. Some of the available combinations and features are outlined here.

The Sorrento™ chair can provide pressure distribution due to the multi-stretch material and reflex foam in the seat cushion and offers a great deal of support with the Tilt in Space mechanism and adjustable lateral supports. The angle of the back can be adjusted to the Patients liking and the elevating leg rest can be raised and lowered, also increasing Patient comfort. The Tilt in Space will allow all angles on the chair to remain the same while tilting the Patient back, allowing their weight to be spread throughout the body and reduce pressure on a given point. The push handle and castors allow the Patient to be transported in the chair and the chair is fully hoist accessible, reducing moving and handling significantly. The removable arms allow width adjustment and also facilitate side transfers. The Sorrento™ the arm height, seat depth and width and foot board height and angle are all fully adjustable.



WHAT IS THE INTENDED USE OF THE PRODUCT?

The Sorrento™ is designed for the comfort of those who sit for long periods. It is used in rehabilitation and also for clients with progressive conditions. Its adjustability allows greater comfort for the Patient and accommodation of their changing needs. This adjustability can also accommodate the needs of multiple Patients. For those who require support in the trunk and a certain degree of head support, the Sorrento™ accommodates these needs by using laterals and various head supports.

The Sorrento™ provides pressure distribution due to the multi-stretch material and reflex foam in the seat cushion due to the ergonomic design and Tilt in Space mechanism a comfortable seating position can be achieved. The back can be reclined to a rest position by the User to accommodate fixed hips. The tilt in space and leg rest can then be operated without changing the back angle, reducing the risk of compromising the position of the pelvis.



PRODUCT FEATURES

Sorrento™

The Sorrento™ can have a manual reclining back and the option of a manual or powered tilt mechanism and elevating leg rest. The electric system allows the Patients' position to be changed with a reduced moving and handling risk. It also has the option of a foot board, adjustable in height and angle to accommodate plantar and dorsal flexion and adjustable height and width lateral supports to assist in stroke therapy or with spinal deformities. With braking castors at the rear and non-braking castors to the front of the seat and a push handle, this chair can be used for mobility/transportation around the environment it is used in.

In addition, the removable arms facilitate side transfers and allow more space for adding and removing slings for a hoist. Various head supports can be used to support the position of the head for improved function and comfort. Options include concave supports, horseshoe supports, lateral supports, seat belts, trays and removable and washable arm and seat covers. To order any of these items after delivery of your chair, please contact Seating Matters on info@seatingmatters.com, +4428 777 66624 or your local Seating Matters provider.

PRODUCT WARRANTY DETAILS:

The Sorrento™ holds a 2 year warranty from the date of manufacture and a 3 year frame warranty, where reasonable care has been exercised.



SAFETY INSTRUCTIONS

ALL INSTRUCTIONS MUST BE READ AND UNDERSTOOD BEFORE THE PRODUCT MAY BE USED.

- When the Sorrento™ is not in transit, all the braking castors on the product must be engaged to prevent risk of injury when being used.
- Under no circumstances must the User or Patient stand or sit on the foot board of the Sorrento™.
- As far as possible, the Patient specific adjustments should be made when the Patient is not in the chair to avoid injury. These include head support, back height, seat depth, foot board height and foot board angle adjustments.
- Care must be taken when making the adjustments on the chair to avoid injury to the User and Patient. Only a competent person should make adjustments to this chair. If in doubt as to any of the adjustments, feel free to call Seating Matters direct or your local Seating Matters provider.
- Keep all body parts away from the mechanisms under the chair. Repairs and maintenance should only be carried out by fully trained technicians.
- Exercise care in using the release lever for the reclining mechanisms and adjustments to avoid injury.

- The User must ensure that the Patient has a period out of the chair after prolonged sitting to raise tissue oxygenation levels. Although the chair offers pressure reduction, the body tissue still needs time to recover. A maximum of 2 hours sitting is recommended at any one time. You must also observe Patient specific recommendations and guidelines as set by their health professional with regard to pressure care.
- For the safety of the User and Patient and to ensure longevity of the electrics on powered options, please ensure that your Sorrento™ is charged nightly using a Seating Matters charger through the handset of the chair. For further details or replacement chargers please contact your Seating Matters provider.
- The chair should not be transported in a vehicle while the Patient is seated on the chair.

ASSEMBLY AND INSTALLATION GUIDE

- This chair should arrive with you fully assembled. The User must ensure that the product is in good condition before use (check all nuts and bolts are fastened, fabric in good condition etc). If there are any problems, these must be reported to your Seating Matters provider and corrected before the chair is put into use.
- The product must be used on a level, plane, hard surface with the brakes engaged to avoid it moving during use and to ensure stability.
- The product must be clear of any obstacles before reclining the back to avoid damage to the chair and objects in its immediate environment.
- The product may not be left in an outdoor environment. More information on fabrics and their environment can be found below.

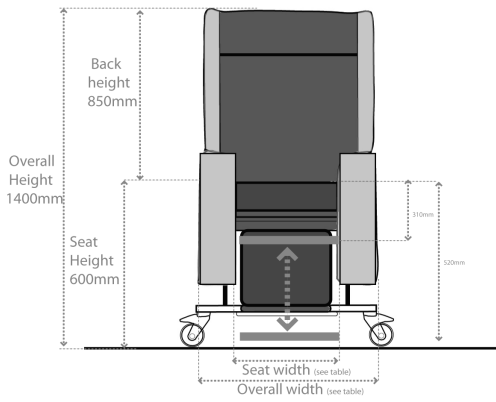

AVAILABLE SEAT AND OVERALL WIDTH

SEAT WIDTH mm	OVERALL WIDTH mm
350	665
400	665
450	715
500	765
550	815
600	865

Footplate Height Adjustment

High	310mm from seat
Low	520mm from seat

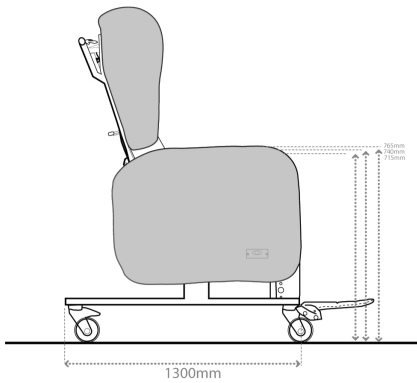

Arm Height

High	765mm
Medium	740mm
Low	715mm

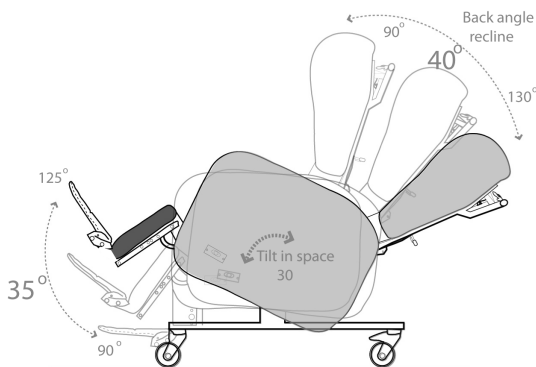

Chair weight unloaded is 62 Kg/136.68lb/9.7 Stone.



USER GUIDE AND OPERATING INSTRUCTIONS

Please Note:

- **BRAKING CASTORS:** The Sorrento™ chair must be used on a plane, hard surface with the brakes engaged to ensure stability and to avoid the device moving undesirably during use. Braking castors, where provided, must be in the braked position while in use (fig. 1) A competent person, trained in the

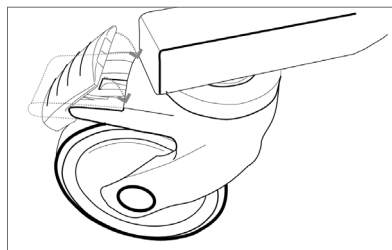

use of the chair, should make adjustments and set it up according to the User requirements and Patient dimensions before the Patient sits in the chair. Ensure there is more than one competent person there when making adjustments to ensure they are correct and safe for the Patient. Ensure all fixings are secure before allowing the person to sit in the chair. This includes lateral supports, arm adjustments, seat adjustment and foot board. Please call your Seating Matters provider if you have any questions on these points. This product should not be lifted at any time unless by competent persons trained in such manual handling.

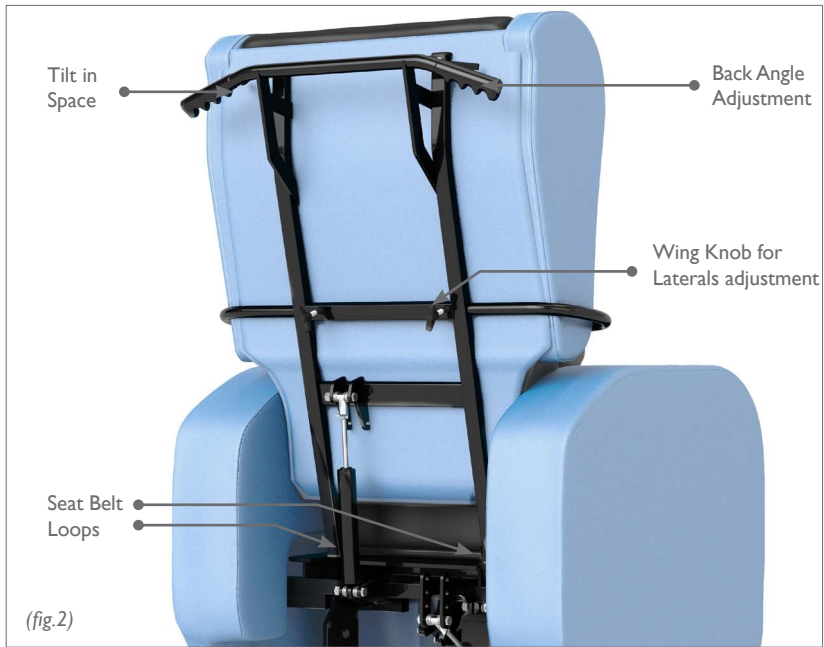

- BACK ANGLE ADJUSTMENT:**
 To recline the back of the chair, the User must inform the Patient then stand behind the chair, and with two hands, firmly hold the push handle while closing the release lever (fig. 2a). Move the back of the chair slowly until it is in the required position and allow the release lever to move to its relaxed position before letting go of the push handles. (fig.2) In powered options, exercise care in case of injury to the Patient or damage to the surrounding environment. Adjustments are performed according to the buttons on the handset.
- TILT IN SPACE:** To tilt the chair, the user must inform the Patient then stand behind the chair with two hands, firmly

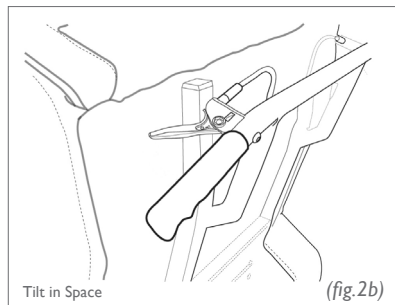
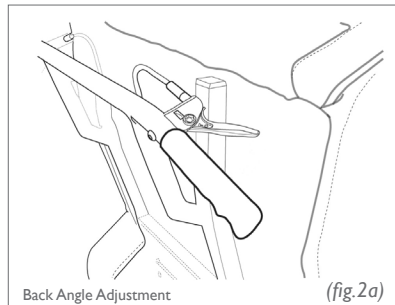

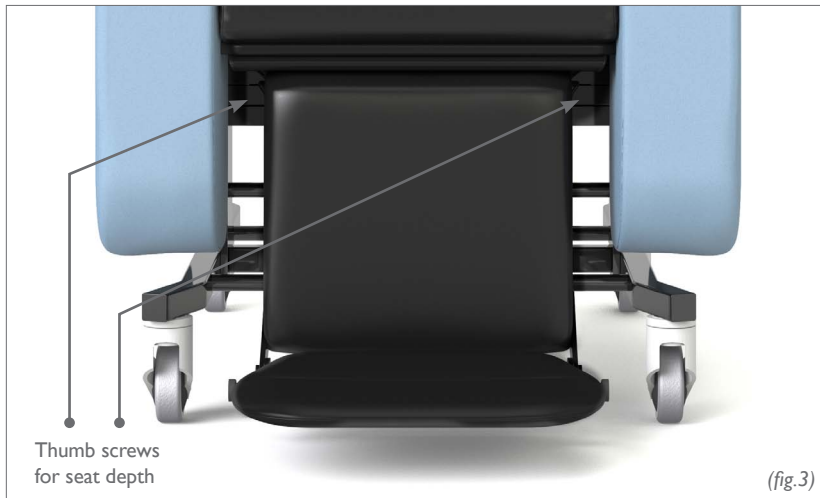

hold the push handle while closing the release lever. (fig.2b) Tilt the chair to the required position then let go of the release lever. In powered options, exercise care in case of injury to Patient or damage to surrounding environment.

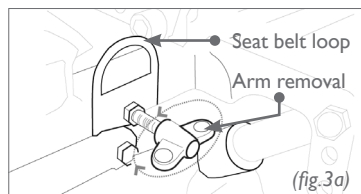

- **SEAT DEPTH:** To increase or decrease seat depth, loosen the **thumb screws** set at 45 degrees under the seat. (fig.3 & fig.3b) Adjust the seat to the required depth by carefully pulling the seat out. Tighten the screws again to ensure the seat depth doesn't unintentionally change. (fig3b)

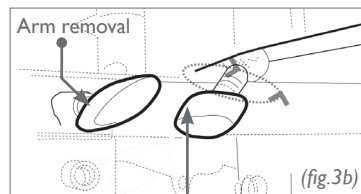

- **ARM REMOVAL:** To remove the arms, loosen the thumb screws behind and in front of the arm (fig.3a & fig.3b) and carefully pull the arm out, leaving it in a safe place to avoid tripping hazards or other injuries. When replacing the arms, ensure the thumb screws are tightened against the frame of the arm.
- **SEAT WIDTH:** To increase the seat width of the chair, loosen the thumb screws behind and in front of the arm (fig.3a & fig.3b) and carefully pull the arm out. This can be set at any position. Ensure the thumb screws are tightened again to hold the arm in position.

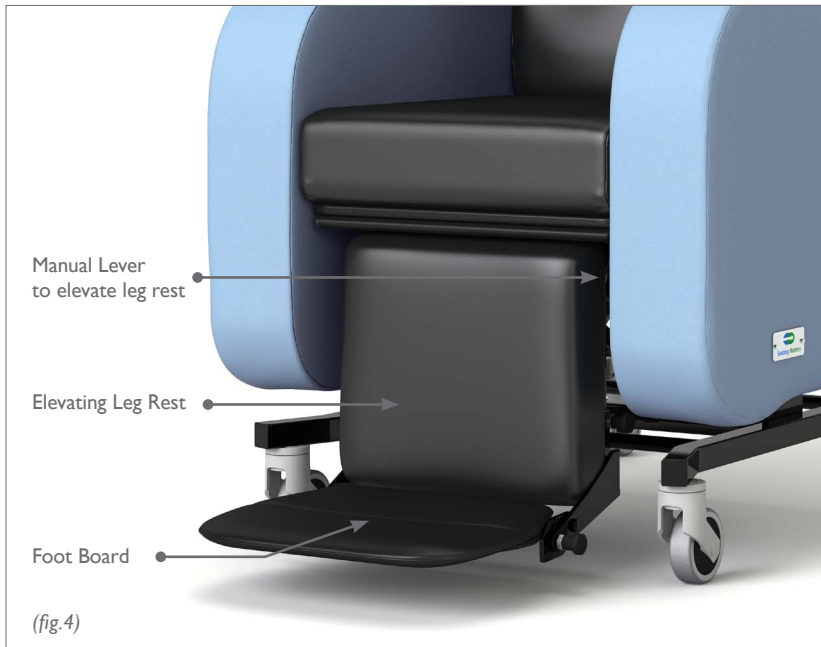

- LEG ELEVATION:** Before changing the angle of the elevating leg rest, the User or Patient must ensure there are no objects in the immediate environment that could obstruct the leg rest elevation or come into contact with the Patients' legs. Using the **manual lever** located under the front of the seat, move the leg rest until it is in the required position and allow the release lever to move to its relaxed position. In powered options, use the handset control to move the leg rest until it is in the required position and release the button. **Ensure that only the weight of the Patients legs are placed on this leg rest.**
- FOOT BOARD HEIGHT:** The foot board can be adjusted in height by pulling out the spring plungers and sliding it up

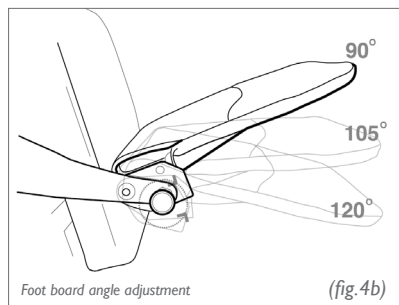
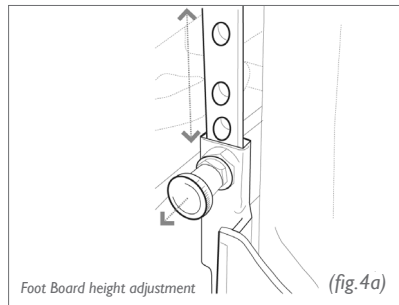

and down on the glide rail. (fig.4a) When the spring plungers are released, they will catch into the nearest hole immediately below the pins. The foot board can also be removed by dropping it off the bottom of the chair.

- **FOOT BOARD ANGLE:** Pull out to the spring plungers at the foot board and rotate to lock out. (fig.4b) Ensuring the feet are supported, adjust the angle of the foot board up or down. When the desired angle is reached, rotate the spring plungers and ensure they click into position. For those who stand transfer, ensure the leg rest is fully retracted from its' elevated position. Fold the footboard against the calf pad. Tilt the chair forward to a safe position for the Patient and perform the stand transfer. At no point should anyone stand or sit on the foot board.
- **CHAIR MOVEMENT:** To move the chair around, ensure that the back is in a fully upright position and push using the push handle on the back. Only a competent person should move this chair.
- **SEAT CUSHION:** The seat cushion on the Sorrento™ is a waterproof, pressure reducing breathable medium foam cushion providing pressure relief and comfort. The seat cushion will have Velcro on one face and a zip closure on one side.
To fit the seat cushion to the chair, ensure the Velcro is on the bottom and makes contact with the Velcro already on the base board, with the zip closure at the rear. This is important as the foams' structure allows good immersion and envelopment of the body ONLY when fitted as instructed.

ACCESSORIES

THE FEATURES OF YOUR SORRENTO™ CHAIR CAN BE ENHANCED BY THE ADDITION OF SEVERAL ACCESSORIES AND OPTIONS. KEY ACCESSORIES ARE OUTLINED BELOW, THE FULL RANGE CAN BE VIEWED AT WWW.SEATINGMATTERS.COM

- **HEADRESTS:** There are various types of headrests available for the Sorrento™:
Each headrest is attached using a belt and a series of buttons. Place the support behind the head and position it at a suitable location for the Patient. Use the buttons to clip the head support in place around the push handle and avoid it slipping down the Patients' back. (fig.5)



- LEG LATERALS:** The height adjustable leg laterals are double sided and has pressure reducing foam and a Dartex covering. Two can be used on the one chair to give maximum support of the lower legs and is recommended to reduce the risk of Patient injury from the foot board hardware.

The Leg Laterals are added to the same hardware that the height adjustable foot board attaches to. First remove the foot board by pulling out the spring plungers and dropping it off the bottom of the chair. On the foot box, pull out both spring plungers and slide it onto the glides of the calf panel. Locate to the desired height or position and reattach the foot board.
- LATERAL SUPPORTS:** Two individual lateral supports which include pressure reducing padding can be added to this chair.

Insert the tubular end of the lateral into the mounting hardware on the back. Being careful to meet the Patients' support needs, move the lateral to the desired position and lock it in place using the adjustable wing knobs at the back.(fig.2)
- SEAT BELT:** The Seating Matters two point belt is only to be used for positioning in accordance with facilitator local regulations regarding restraint.

*Adjust the belt to the desired length. Clip the two metal ends of the belt onto the two **seat belt loops** on the hardware of the chair. (fig.2) Pull to ensure it is locked in place. Fasten the belt to a safe and suitable position on the Patient. Monitor and check regularly in accordance with facility or local regulations regarding the use of the belt. The positioning belt **should not** be used for restraint purposes.*
- SEAT CUSHION COVER:** This washable cover is made from Dartex material and will fit over the existing seat cushion cover of the chair. Ensure the flat panels are to the side of the seat cushion and the continuous Dartex panel of the seat cover goes from the front to the back of the cushion.
- ARM COVER:** One or two washable arm covers can be used on the chair to increase its' longevity and improve hygiene.

Arm covers will fit on tightly over the arm of the chair Ensure they are pulled right down as far as possible over the arm

- **TRAY:** A full tray for positioning support and to facilitate meals and activity can be added to the chair. It is only to be used in accordance with facility or local regulations regarding restraint.

Place the tray on the top of the arms, with the concave part towards the Patients' body. Using the belt attachments, clip the four belts in place at the bottom of the arm. Ensure the tray is in a comfortable and safe position for the Patient Monitor and check regularly in accordance with facility or local regulations regarding the use of the tray.



WORKING ENVIRONMENT

- **DARTEX MULTI-STRETCH:** Waterproof, stain resistant, flame retardant, multidirectional stretch for pressure relieving situations – i.e. seat cushion, calf panels, lateral supports and seat back.
- **VINYL:** Non-absorbent, anti-bacterial, flame retardant, strong, durable material for outer arms, outside back etc.

CLEANING AND MAINTENANCE OF FABRICS

- **Vinyl: (Arms and outside back)** Stain Resistance: Our vinyl is resistant to urine, most household stains, mild acids/alkalis, drinks and beverages as they are not absorbed and can be wiped off without any problem or lasting damage. Some difficult substances such as lipstick, ball point pen ink and food colourings should be cleaned off immediately to avoid permanent staining.
- **Cleaning:** To ensure proper cleaning and longevity of the fabrics, the chairs should be cleaned with warm soapy water followed by a clean water rinse to help retain the attractive appearance and durability. Heavy, ingrained soiling may be removed by scrubbing with a soft brush. Strong detergents, solvent cleaners, polishes or patent chemical cleaners should not be used as they are unnecessary and may cause embrittlement and cracking of the material. Additional Care – special attention should be given to head rest and arm rest areas, as build-up of body oils in these areas will gradually cause the vinyl to harden.

DARTEX MULTI STRETCH FABRIC (BLACK PATIENT CONTACT SURFACE)

Properties - This fabric is waterproof, has the ability to be wiped clean and has biostatic (anti-mycotic) coatings to provide an impenetrable barrier to virus and bacteria. Superficial dirt may be removed by wiping with a soft cloth moistened with water containing a neutral detergent. More persistent contamination may be treated by wiping with alcohols or turpentine substitute, followed by hot water and detergent. Routine cleaning and disinfection may be carried out on the coating with hand hot water and a neutral detergent or with a sodium hypochlorite solution (0.1% or 1000 parts per million available chlorine). The material is compatible with the 10,000ppm available chlorine in solution required for the decontamination of blood spills. Excess solution must be removed and the surface thoroughly rinsed and dried prior to reuse or storage. Proprietary disinfectants may be used provided manufacturer's instructions are followed. All cleaning agents, and disinfectants, must be thoroughly rinsed off and the item dried

before storage. Failure to do this may result in damage to the polyurethane coating, react with the chair frame, or negate the biocompatibility results of the fabric. It is essential that articles be thoroughly dried after all cleaning procedures and before storage.

END OF LIFE (DISPOSAL)

Please contact Seating Matters for disposal of your chair at the end of its lifespan. Batteries may only be disposed of according to your local legal guidelines.

SAFETY

The Sorrento™ is CE marked to show conformance to the Medical Devices Directive 93/42/EEC and conforms to BS ISO 7176 at medium hazard.

SORRENTO™ MAINTENANCE AND SERVICING

Regularly servicing your Seating Matters chair will prevent untimely and inconvenient breakdowns, reduce repair costs down and extend the chairs' life. Damage to the chair can also cause excess strain for the User and Patient.

IMPORTANT!

Parts can only be changed by service persons trained in Seating Matters products and use only Seating Matters parts. We recommend that your chair is serviced every year by a Seating Matters approved provider for any running repairs and maintenance.

MAINTENANCE

Carry out the following regular checks to ensure the operation and safety of the chair. If you are in any doubt about the functioning of your chair contact your Seating Matters approved provider immediately.

DAILY

- Check that the castors are not damaged.
- Check that the castors turn freely.
- Make sure that the castor forks run free and are not bent.
- Check all fabrics for damage or contamination and replace where necessary.
- See Cleaning and Maintenance of Fabrics section in manual for cleaning instructions.
- Check batteries and electrical connections are secure.

WEEKLY

- Check the castors fittings for hair and dirt etc. which could restrict the castor movement.
- Pick out any such material with tweezers or take the spindle out, clean it and then replace it.
- If it is still not free (one continuous turn without it sticking) contact your Seating Matters approved provider for replacement.

MONTHLY

- **CASTORS:** Make sure the top of the castor housing is parallel with the floor. Any variation will cause restricted movement. If it is damaged contact your Seating Matters approved provider for replacement.
- **MECHANISMS:**
 - Check all tilting mechanisms are working smoothly.
 - Check that cables are not kinked or frayed.
 - Check that all nuts and bolts are present.
 - Check that all nuts and bolts are secure.

Note: If nuts or bolts need attention, contact your Seating Matters approved provider IMMEDIATELY and DO NOT USE the chair until it has been serviced.

- **LEG RESTS:** Check that all leg rests are easily removed/swung-away and replaced or repositioned easily. Ensure that parts lock in place securely. If parts are not locking try lubricating. If the problem still remains contact your Seating Matters approved provider.
- **FRAME:** Check the visible parts of the frame for cracks, splits, large dents or other damage. If you find any of these things DO NOT USE. Contact your Seating Matters approved provider immediately.

**WE'RE HERE
TO HELP...**

**FOR ANY QUESTIONS OR QUERIES REGARDING YOUR
SEATING MATTERS CHAIR PLEASE CONTACT:**

info@seatingmatters.com

VIEW OUR FULL RANGE OF CHAIRS & ACCESSORIES ONLINE...



WWW.SEATINGMATTERS.COM

**MANUFACTURED BY:
SEATING MATTERS LTD.**

Limavady

N Ireland

BT49 9JG

+4428 777 666 24

info@seatingmatters.com

