

WILDFIRE DOT

1/10 4WD ELECTRIC COMPETITION TOURING CAR KIT

SETUP SHEET

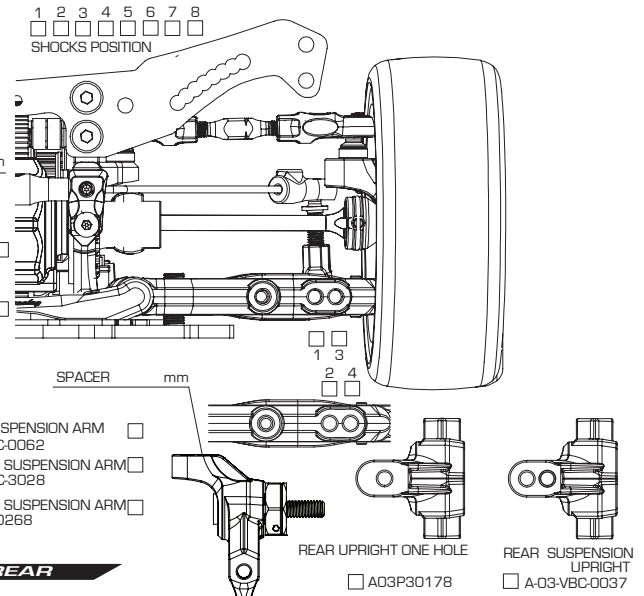
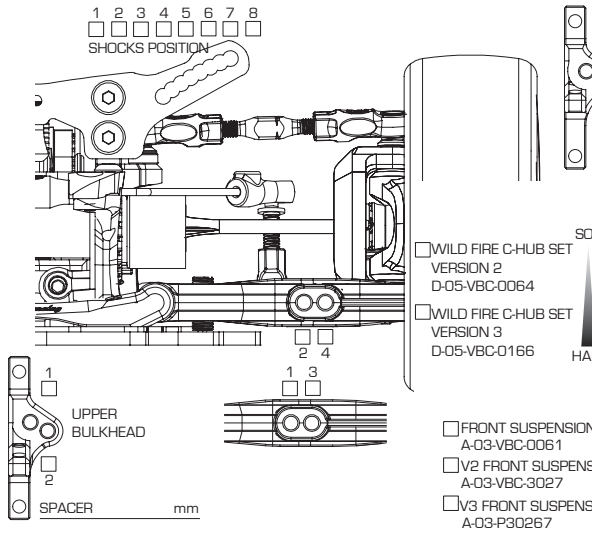

FRONT

GROUND CLEARANCE mm DROOP _____

CAMBER ANGLE ° TOE ANGLE _____

CASTER BLOCK ° FRONT DRIVE DIFF (OIL) / DIRECT _____

STABILIZER 1.2 1.3 1.4 WHEEL SPACER mm _____

SUSPENSION SHIM (FF) mm SUSPENSION SHIM (FR) mm _____

SUSPENSION MOUNT (FF) _____ SUSPENSION MOUNT (FR) _____

AXLE TYPE / SIZE TWO-PIECE JOINT / SINGLE JOINT (STEEL/ALUM) mm _____

REAR

GROUND CLEARANCE mm DROOP _____

CAMBER ANGLE ° TOE ANGLE _____

REAR DRIVE DIFF (OIL) DRIVE CUP ALUMINUM / STEEL _____

STABILIZER 1.2 1.3 1.4 WHEEL SPACER mm _____

SUSPENSION SHIM (RF) mm SUSPENSION SHIM (RR) mm _____

SUSPENSION MOUNT (RF) _____ SUSPENSION MOUNT (RR) _____

AXLE TYPE / SIZE TWO-PIECE JOINT / SINGLE JOINT (STEEL/ALUMINUM) mm _____

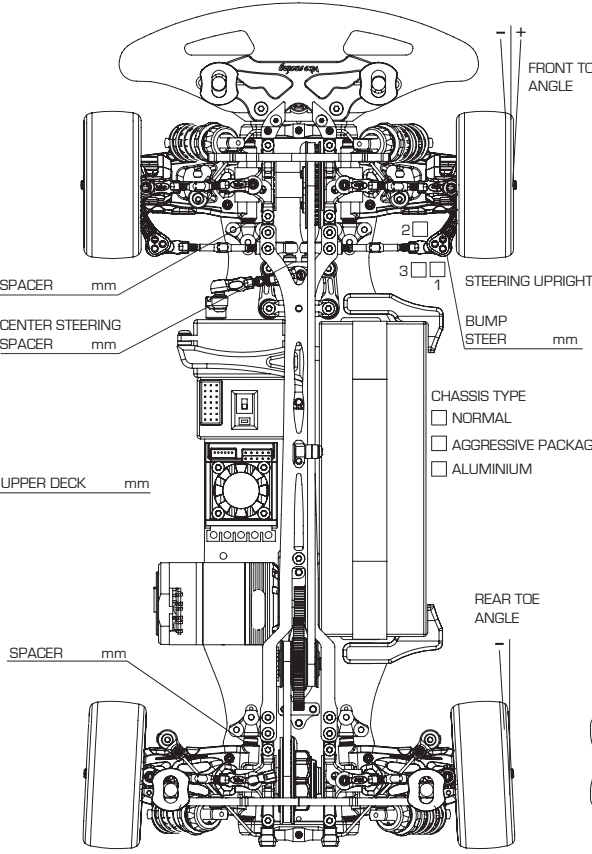

FRONT

SHOCK LENGTH mm _____

PISTON 3 4 hole(s) / OTHERS _____

OIL _____

SPRING _____

OIL SEALER CAP S / MS / M / H _____

REBOUND % _____

NOTES _____

MOTOR SPUR PITCH/ T PINION PITCH/ T _____

TIRE TIRE INSERT WHEEL _____

TIRE ADDICTIVE BODY REAR WING _____

ESC BATTERY _____

REMARKS _____

REAR

SHOCK LENGTH mm _____

PISTON 3 4 hole(s) / OTHERS _____

OIL _____

SPRING _____

OIL SEALER CAP S / MS / M / H _____

REBOUND % _____

NOTES _____

Chassis Flex Settin (Fill in the Circle)

