

(Ver. 03/2022)

OWNER'S MANUAL

Direct Connect Under Sink Water Filtration System



Frizzlife
SED10R
Recommended replace period: **3-6M**
Removes sediments, sands, dirt, rust, debris, and other large particles.
Operating Temp: Min. 39°F/Max. 100°F
Flowing Pressure: 20psi/Max. 80psi
Flow Rate: 2 GPM @ 60 psi
WARNING:
Do not drink water that is microbiologically unsafe or contains harmful chemical substances distributed to you after the system. The actual performance of the product may vary depending on the conditions of use and water.
INSTALLER ONLY
Please refer to the manual of the case filter for the correct installation of your best water quality and water usage.
Frizzlife Inc.
www.frizzlife.com
Email: support@frizzlife.com
Install Date: _____

Frizzlife
CP10R
Recommended replace period: **8-12M**
Removes Chloramine, Sediment, Chlorine, and Bad Taste.
Operating Temp: Min. 39°F/Max. 100°F
Flowing Pressure: 20psi/Max. 80psi
Flow Rate: 2 GPM @ 60 psi
WARNING:
Please do not drink water that is microbiologically unsafe or contains harmful chemical substances distributed to you after the system. The actual performance of the product may vary depending on the conditions of use and water.
INSTALLER ONLY
Please refer to the manual of the case filter for the correct installation of your best water quality and water usage.
Frizzlife Inc.
www.frizzlife.com
Email: support@frizzlife.com
Install Date: _____

Frizzlife
CB10R
Recommended replace period: **12-18M**
Removes Lead, Other Heavy Metals, Sediment, Chlorine, and Bad Taste.
Operating Temp: Min. 39°F/Max. 100°F
Flowing Pressure: 20psi/Max. 80psi
Flow Rate: 2 GPM @ 60 psi
WARNING:
Please do not drink water that is microbiologically unsafe or contains harmful chemical substances distributed to you after the system. The actual performance of the product may vary depending on the conditions of use and water.
INSTALLER ONLY
Please refer to the manual of the case filter for the correct installation of your best water quality and water usage.
Frizzlife Inc.
www.frizzlife.com
Email: support@frizzlife.com
Install Date: _____

FRIZZLIFE

CONTENT

1. BEFORE INSTALLATION	01
2. PRODUCT INTRODUCTION	02
3.SAMPLE CONNECTION	02
4. INSTALLATION STEPS	03
5. REPLACEMENT FILTER	05
6. FILTER REPLACEMENT INSTRUCTION	05
7. MULTI-USAGE	06
8. PERFORMANCE DATA	06
9. FREQUENTLY ASKED QUESTIONS	07
10. LIMITED PRODUCT WARRANTY	07
11. WARRANTY REGISTRATION	08

If you have problems during the purchase or installation process, please contact our customer service.

 www.frizzlife.com

 support@frizzlife.com



FOLLOW US @Frizzlife

Receive first-hand promotion info and be the first one getting exclusive benefits.

Register to activate your warranty with Frizzlife.

- › Scan the QR code to register
- › Email us your order ID and full name at support@frizzlife.com



Find the Installation Video

- › Search “Frizzlife TW Series Installation” on www.youtube.com

1. BEFORE INSTALLATION

› Inspect Box

Please take out the system and all the components from the box. Inspect them carefully according to “Product Introduction”, and make sure nothing is missing or damaged during shipping. If any parts are cracked or broken, please do not proceed with installation, and contact Frizzlife for an exchange or diagnosis.

› Technical Parameters

Model No.	TW10	TW15	TW20
Dimension	4.7*15.7*14.6 in	4.7*15.7*19 in	4.7*15.7*21 in
Replacement Filter	SED10R, CP10R, CB10R	SED15R, CP15R, CB15R	SED20R, CP20R, CB20R
Replacement Period	3-6M, 8-12M, 12-18M	4-8M, 12-18M, 16-24M	8-12M, 16-24M, 24-36M
Flow Rate	2 GPM @ 60 psi		
Applicable Water Source	Municipal Water		
Operational Temp	Min.39°F,Max 100°F		
Working Pressure	Min.20psi, Max. 80psi		

› Precautions

- Do not use it with water that is microbiologically unsafe or of unknown quality without adequate disinfection.
- For cold water use only.
- Do not freeze the filter, as this case cause cracking and water leakage.
- Do not allow children under 3 years of age to have access to small parts during the installation of this product.
- Testing was performed under standard laboratory conditions, actual performance may vary.
- This installation must comply with all applicable state and local regulations.
- Please flush water for 15 minutes for the first time usage.

2. PRODUCT INTRODUCTION

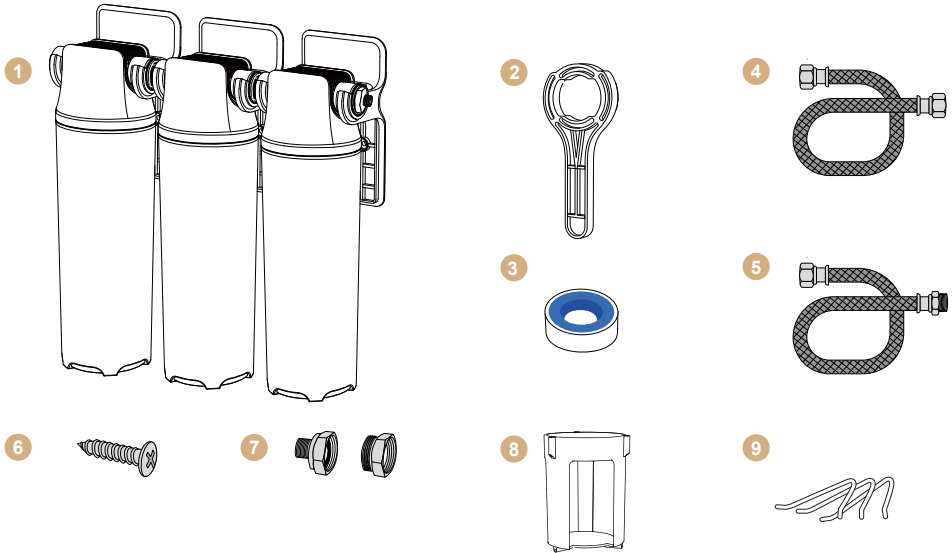

1 TW10/TW15/TW20 Filter System with Filter Loaded

2 Wrench

3 Plumber Tape

4 3/8" inlet hose

5 3/8" Outlet hoses ×2

6 Mounting Screws

7 3/8" -1/2" Converter set

8 System Holder ×2

9 Spring Wires for Holder ×6

3. SAMPLE CONNECTION

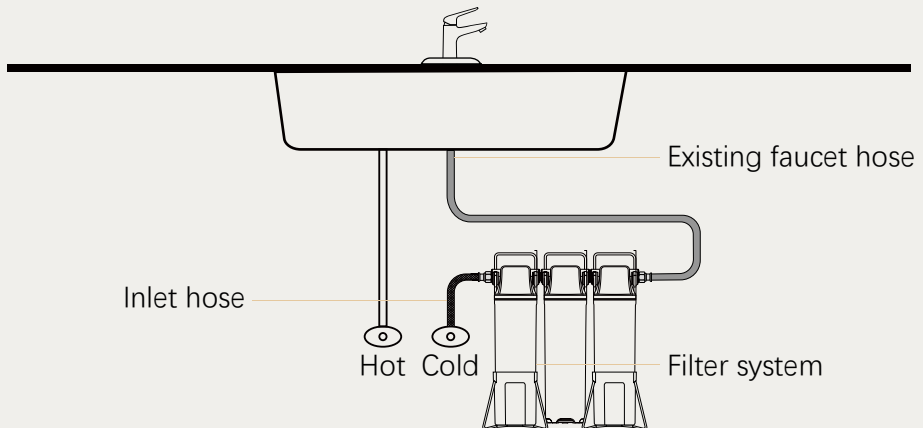

4. INSTALLATION STEPS

⚠ Note: Please always use plumber tape on threaded connection parts to ensure a watertight seal.

› **Step 1: Mount the system or set the system on the ground by using the holders.**

Option 1: Mount the system (onto a wooden plate)

1. Find the proper place to mount up the system.
2. Screw off the cartridges.
3. Mount up the filter heads using the provided screws. (Please use at least 6 screws to fasten the system.)
4. Screw back the cartridges.

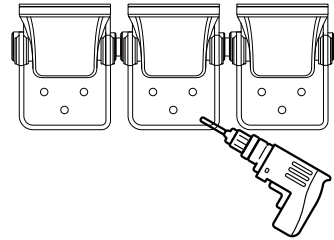

Note: Leave at least 2 inches higher than the ground for easier filter replacement.

Option 2: Set the system on the ground

1. Setup the holder on flat ground.
2. Insert the long side end of the wire into the upper hold of the holder. Insert the other end into the base hole.
3. Make sure all the spring wires of the holder stretch out steadily.

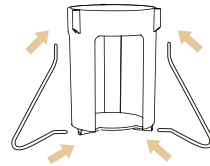

4. Set the system on the holders.

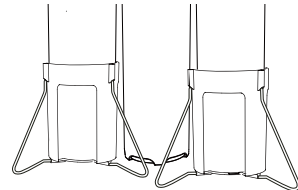

› **Step 2: Connect the water hose**

1. Connect the inlet hose to the "Inlet" port.

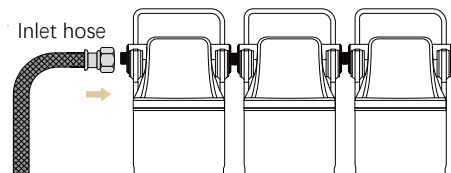

⚠ Note: If your angle valve is 1/2", please install the converter provided firstly.

IF ANGLE VALVE OUTLET IS 3/8"

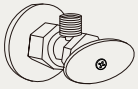

3/8" Comp(9/16" thread)

IF ANGLE VALVE OUTLET IS 1/2"

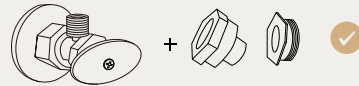

1/2" thread



connect one part of the adaptor to the angle valve

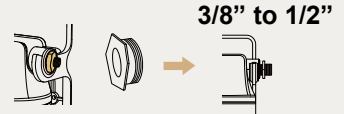

connect the other part of adaptor to the outlet port

› Step 3: Connect the water supply
(COLD WATER ONLY)

1. Shut off the water supply
2. Remove the feed water hose from the angle valve
3. Connect the inlet hose to the feed water valve

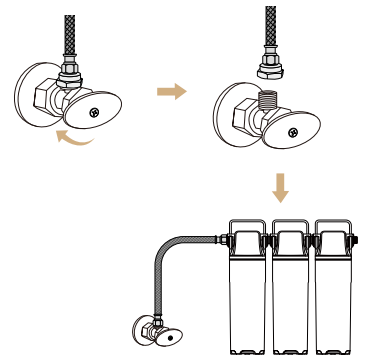

› Step 4: Connect to the main faucet

1. Connect the existing faucet hose to "Outlet" port of the system

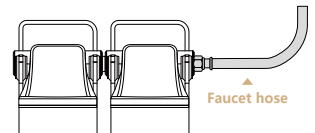

If your existing faucet hose is not long enough, please select and use the proper outlet hose provided to finish connection.

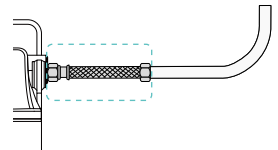

› Step 5: Check for leaks

1. Turn on the water supply valve to check for leaks
2. Flush the system for 15 minutes before use

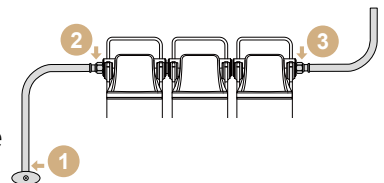

5. REPLACEMENT FILTER

The Frizzlife Under Sink Water Filter System requires care and cleaning after a period of time. It is recommended to change the cartridge according to corresponding time intervals in the table below. If the system has been working properly and the filtered water output is slowing down, it may be time to change the filter cartridge.

System Model No.	Replacement Filter No.	Filtration Capacity
TW10	SED10R, CP10R, CB10R	3-6M, 8-12M, 12-18M
TW15	SED15R, CP15R, CB15R	4-8M, 12-18M, 16-24M
TW20	SED20R, CP20R, CB20R	8-12M, 16-24M, 24-36M

⚠ Note: All the service life of the filter cartridge listed are based on actual laboratory test and the provided water. The actual service life of filter cartridge depends on source water quality and daily water usage.

6. FILTER REPLACEMENT INSTRUCTION

⚠ Note: With the Auto Shut off design of the system, you do not need to shut off the water supply when doing the replacement.

› Step 1: Twist the cartridge housing(s) clockwise

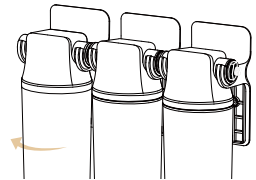

› Step 2: Using the wrench to unscrew the housing body

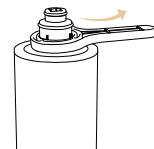

› Step 3: Take out the old cartridge and load with new one, then install back in the same way

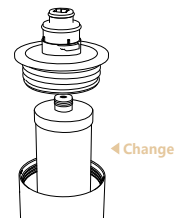

› Step 4: Flush the new cartridge for 15 minutes before starting to use

7. MULTI-USAGE

The TW Series system can be connected to your refrigerator / ice maker by utilizing Frizzlife **IMC-2 connection** (not included).

› Simply search “**Frizzlife IMC-2**” on Amazon or scan the QR code below to purchase.

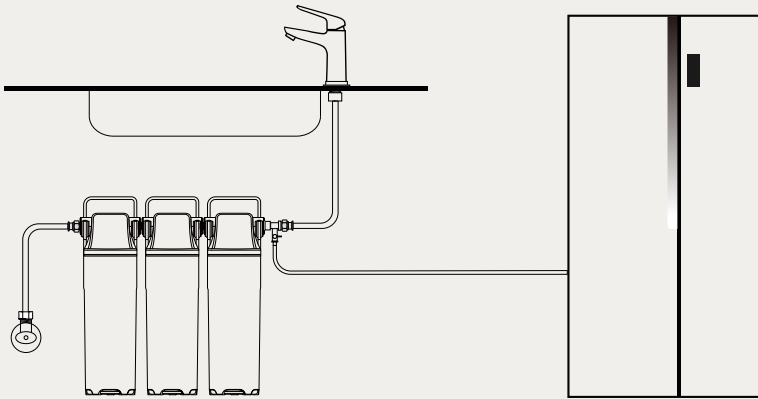

8. PERFORMANCE DATA

Substance	Influent challenge concentration (mg/L)	Maximum permissible product water concentration (mg/L)
Chlorine	2.0 mg/L \pm 10 %	\geq 50%
Particulate, Class I Particles 0.5 to $<$ 1 μ m	At least 10,000 particles/ml	\geq 85%
Lead	0.15 \pm 10 %	0.010
Cyst	Min. 50,000/L	99.95%

9. FREQUENTLY ASKED QUESTIONS

› Q: What should I do if water leaks after installation?

A: If once installed the system should leak, please shut off water supply firstly. If the leaking occurs at the thread, please wrap plumber tape on the external thread. Please contact Frizzlife customer service team for solutions if the water leakage persists.

› Q: Why TDS does not drop after filtration?

A: TDS is not a professional way to test the water quality. TDS means total dissolved solids, for example if you put a very little salt(NaCl) into the water and test the TDS, and you will find the result is dramatically high. Same thing, if your water is full of minerals, the TDS is very high too. The TW Series doesn't remove any of the minerals from water, but only stops harmful contaminants like heavy metals (Lead, Mercury, Cadmium) and over 90% of VOCs and Cysts, and it removes greatly the chlorine (99%) from water. Therefore, it is the reason why TDS you get is not that low as you expect.

10. LIMITED PRODUCT WARRANTY

TW10/TW15/TW20 Under Sink Water Filter System | Warrantor: FRIZZLIFE INC

› ONE YEAR LIMITED FRIZZLIFE WARRANTY

The Frizzlife TW Series Under Sink Water Filtration System are warranted to the original purchaser. To be free of defects in material and workmanship by FRIZZLIFE INC, FRIZZLIFE will replace or repair components of the unit that Frizzlife has deemed to be broken within the limits of the warranty without charge. The customer is not responsible for any freight involved with shipping the item back for inspection and shipment of replacement for items. Frizzlife is not liable for cost of removal, installation, transportation or any other charges in connection with a warranty claim.

Customer must register their systems with Frizzlife within **90** days of purchase in order to obtain a warranty. Warranty will discontinue after the unit is removed from the location where it was originally installed. Warranty begins on the date of delivery of product to the customer.

› Owner's Warranty Responsibility:

As a condition of this Limited Warranty, the owner must ensure that periodic maintenance of the system is performed as described in the literature enclosed with the system. Should your unit develop a defect or otherwise fail to perform in accordance with this warranty, you should contact the retailer from whom the product was originally purchased.

1. Frizzlife is not liable for anything that we deem as abuse of the units, including but not limited to, misuse of product outside of intended use, equipment modifications, unauthorized repairs, improper installation, damage from freezing, hot water, fire or other acts of God outside of Frizzlife control.

This warranty will be void if defects occur due to failure to observe the following conditions:

- | Incoming water to the the system cannot exceed 100°F.
 - | Do not use outdoors or in a location that is subjected to direct sunlight or freezing. This warranty will not be effective unless and until the Frizzlife is shown to have been used in accordance with the installation and maintenance instructions accompanying the product.
 - | The filter cartridges should be replaced in time according to the recommended replacement period.
 - | The plastic housings should be replaced every 18 months.
2. Filter Cartridges are considered as disposable items, thus are not covered by warranty.
 3. Customer is responsible for proper operation, which includes complete and continual leak inspection.
- | Most of the unit components are made of plastic and eventually can break or crack from stress.
 - | There are no other warranties which extend beyond what is described above.

11. WARRANTY REGISTRATION

150% EXTENDED WARRANTY

1. Email us you order ID and full name at support@frizzlife.com within 90 days.
2. Scan the QR code below to register



If you have any questions, any suggestions, or you need any assistance, please free to contact us anytime at support@frizzlife.com.

Your satisfaction is always our top priority!