



ADVANCED PRESSURE SYSTEMS
701 South Persimmon Street | Suite #85 | Tomball, TX 77375
Phone: (281) 290-9950 | **Fax:** (281) 290-9952
Email: sales-team@advancedpressuresystems.com
<https://www.advancedpressuresystems.com>

Dear Customer,

Advanced Pressure Systems (APS) is a manufacturer of a full range of products in the 15K, 20K and 40K psi pressure ranges. We are also an authorized United States Distributor of TurtleSkin protective clothing and a StoneAge Tools Authorized Reseller, and we are a major supplier of Parker PolyFlex and Spir Star hoses and flex lances. We are pleased to provide you with our latest water blasting equipment and accessories catalog.

Advanced Pressure Systems is dedicated to providing our customers with the best service available anywhere in the water blasting equipment supply field. We have an excellent record of delivering the best products when and where they are needed. Relentless review and improvement of all aspects of our service to the customer is still our everyday objective. Our professional engineering team provides innovative problem solving, and our friendly sales and support personnel are always available and ready to help with their excellent product knowledge.

APS products are designed to be compatible with water blasting industry standards, wherever possible, and we use the cartridge concept for replacement of wear parts in our products, which is consistent with current best practices. Our international customers should be aware that our control guns, flow dividers, pressure regulators, nozzles and fittings can also be supplied with metric or BSPP connections.

We look forward to hearing from you soon.

Yours Truly,

Affiliated Companies and Associations



APS Staff

Advanced Pressure Systems was established in April 2007, but the cumulative experience of our people means that we offer a wealth of water blasting knowledge that rivals even our older competitors. We are committed to the success of all of our clients and will do everything within our power to help you realize that success.



Peter Goldsmith
Managing Director



David Mitchell
Director of Operations



Kent Maddie
Vice President of Sales



Johnny Matsoukas
Branch Manager



Kenny Kujawa
Manufacturing Partner

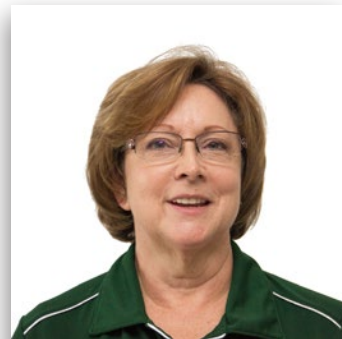

Sheree Paramore
Production Control



Patty Enstrom
Office Manager



Fabian Villanueva
International Sales



Nick Ragan
Sales Representative

Our headquarters is in Tomball, TX, and we have a secondary sales office and distribution center in La Porte, TX, near the Ship Channel. We are a growing company with roots firmly planted in the water blasting industry. Our clients are worldwide, and that means something. We provide unmatched customer service, products and price.

Our family is always growing, and if you would like to become an APS Authorized Distributor we would love to speak with you. Please call our headquarters to request a Distributor Request Form, and someone will respond to you promptly.

BELOW ARE JUST A FEW OF OUR INTERNATIONAL DISTRIBUTORS

- **Alberta:** Riverstone Waterjets
- **Mexico & Central America:** Prisma CID, S.A. DE C.V.
- **Ontario:** Industrial Mechanical Specialties, Ltd.
- **United Kingdom:** Calder, Ltd.
- **Europe & Scandinavia:** Salomon Jetting Parts B.V.
- **Gulf Cooperation Council Countries:** Asia Waterjet Equipment FZCO



TUBE NOZZLES

• Standard Tube Nozzles	8
• Standard Tube Nozzles w/ Tungsten Carbide Blade	9
• Turbo Nozzles	10
• Multi-Groove Nozzles	11
• FNPT Nozzles	12
• Button Tip Flex Lance Nozzles	13
• Button Tip Tube Cleaning Nozzles	14-15
• TLX Nozzles	16
• Thruster Nozzles	17
• Monro-Jet Orbital Nozzles	18
• Monro-Jet Orbital Nozzle Repair Kits	19
• Penetrator Nozzles	20
• Evaporator Nozzles	21
• Male Machine Screw Nozzles	22
• Male Machine Thread Lance Nozzles	23

SAPPHIRE NOZZLES

• 1/4"-28 Right Hand High Performance Tested Sapphire Orifice Assemblies	24
• 1/4"-28 Right Hand High Performance Stat-Tested Sapphire Orifice Assemblies	25
• 3/8"-24 Right Hand High Performance Stat-Tested Sapphire Orifice Assemblies	26-27
• 3/8"-24 Right Hand High Performance Patented Sapphire Orifice Assemblies	28-29
• 7/16"-20 UNF High Performance Stat-Tested Sapphire Orifice Assemblies	30-31
• Button Style High Performance Sapphire Orifice Nozzle Inserts	32-33
• Slotted Type High Performance Sapphire Insert Assemblies	34-35
• Hex Type High Performance Sapphire Insert Assemblies	36
• Sapphire Insert Screwdrivers	37

SURFACE NOZZLES

• Pineapple Line Mole Nozzles	38-39
• Stainless Steel Line Mole Nozzle Inserts	40-41
• Tungsten Carbide Line Mole Nozzle Inserts	42
• Tungsten Carbide Hard Hitter Nozzles	43
• Gun Barrel Hard Hitter MNPT Nozzles	44
• 1/4" Meg MNPT Hard Hitter Nozzles	45
• 1/2" NPT Long Hard Hitter Nozzles	46
• Drop-In Tungsten Carbide Hard Hitter Nozzles	47
• Large Ultra-Polished Nozzles & Nozzle Holders	48
• Large Tungsten Carbide Nozzle Assemblies & Replacement Inserts	49
• Stainless Steel 15° & 25° Fan Tip MNPT Nozzles	50-51
• Tungsten Carbide 15° & 25° Fan Tip MNPT Nozzles	52
• Drop-In Tungsten Carbide Fan Tip Nozzles & Control Gun Nozzle Holders	53
• Sand Eductor Nozzles	54
• Carrier Nozzles	55
• Radial Pancake Nozzle Assemblies	56

FITTINGS

• NPTM to NPTF Reducer Bushings	57
• Autoclave Style Reducer Bushings w/ Gland Nuts & Collars	58
• MP-Male to NPT Reducer Bushings	59

FITTINGS (Continued)

- BSPP x NPT Bushings60
- Swage Adapters61
- Metric / BSPP to NPT Adapters62
- Type M x NPT (M) Adapters63
- Adapters MP (M) x NPT (M)64
- Adapters Metric (M) x NPT (M)65
- Adapters MP-Male x MP-Male66
- Autoclave Style Single Piece Adapters MP x Type M67
- Tube Adapters68
- Anti-Vibration Glands69
- Autoclave Style 90° MP Elbows & Tees70
- Gland Nuts & Collars71
- Hose Connectors72
- UNF Lance Connectors73
- Socket Head Plugs & Hex Head Plugs74
- Plugs75
- Heavy Duty Couplings76
- MP x NPT Slimline Couplings77
- Slimline Couplings78-79
- Autoclave Style Straight Couplers80
- BSPP Couplings81
- Screw Type Quick Disconnect Couplings82
- Aeroquip™ Type Quick Disconnect Couplings83
- Wafer Elbows84
- Wafer Crosses, Tees & Wyes85
- Hex Nipples86
- Winged Type Hammer Unions87

LANCES & RELATED

- Dual Lance Manifolds88
- Rigid Lance Holders89
- Pipe & Tube Nipples90-92
- Flex Lance Safety Grips93
- Articulated Flex Lance Safety Stop for Tube Sheet Mount94-95
- Variable Lance Stop Assembly96-97

CONTROL GUNS

- Air Diverter Valves w/o Base Plates98-103
- Air Diverter Valves104-109
- High Volume Air Diverter Valves w/o Base Plates110-113
- High Volume Air Diverter Valves114-117
- Dry Shut-Off Air Diverter Valve118-119
- Foot Operated Dump Guns120-125
- High Volume Foot Operated Dump Guns126-129
- Hand-Held Dump Guns130-137
- Hand-Held Double Dump Guns138-143
- Hand-Held Zero Thrust Guns114-149
- Hand-Held Dry Shut-Off Gun150-151
- Hand-Held Lever Gun152-153
- Dump Gun Handle Assemblies154-156

Table of Contents

CONTROL GUNS (Continued)

• Double Dump Gun Handle Assemblies	157-159
• Dry Shut-Off Gun Handle Assembly	160
• Lever Gun Handle Assembly	161

REPLACEMENT CARTRIDGES

• Dump Cartridges	162-163
• Valve Cartridges	164-165
• Dry Shut-Off Cartridges	166

FLUID ENDS

• Types 3615HF & 4215HF Fluid Ends	167-169
• Types 3620 & 4220 Fluid Ends	171-173

ACCESSORIES

• Pressure Gauges	174
• Snubbers	175
• Pressure Regulating Valves	176-181
• Flow Divider Valves	182-185
• Tri-Mode TumbleBox w/ Dual Air Control Hose Assembly	186-187
• Jetstream Type Port Fittings	188
• Lubricants & Grease	189
• Oils & Precision Measuring Tools	190
• Tool Cleaners & Machine Threading Dies	191
• Coning & Threading Tool Kits	192

SAFETY EQUIPMENT

• Rupture Disc Holder w/ Safety Shroud	193
• Articulated Flex Lance Safety Stop for Tube Sheet Mount	194-195
• Variable Lance Stop Assembly	196-197
• European & Screw Type Safety Shrouds	198
• Hose Whip Restraints	199
• TurtleSkin® CoverAll™ Complete Suit	200
• TurtleSkin® CoverAll™ Complete Jacket	200
• TurtleSkin® CoverAll™ Jacket	201
• TurtleSkin® CoverAll™ Bunker Pants	201
• TurtleSkin® CoverAll™ Arm Inserts	202
• TurtleSkin® CoverAll™ Neck Attachment	202
• TurtleSkin® MFA WaterArmor™ Suit	203
• TurtleSkin® MFA WaterArmor™ Torso Only	203
• TurtleSkin® MFA WaterArmor™ Chaps	204
• TurtleSkin® MFA WaterArmor™ Gaiters	204
• TurtleSkin® MFA WaterArmor™ Gauntlets	205
• TST-Sweden® Overalls w/ Hand Protection	206
• TST-Sweden® Hand Protectors	206
• TST-Sweden® Jackets w/ Hand Protection	207
• TST-Sweden® Waistcoats	207
• TST-Sweden® Waistcoats w/ Apron	208
• TST-Sweden® Aprons	208

SAFETY EQUIPMENT (Continued)

- TST-Sweden® Trousers209
- TST-Sweden® Delta Complete Kits209
- TST-Sweden® Sigma Complete Kits210
- TST-Sweden® Gamma Complete Kits210
- TST-Sweden® Gaiters211
- TST-Sweden® 30/30 Boots 3000211
- TST-Sweden® Balaclava212
- TST-Sweden® Head Protection Helmet w/ Visor & Hearing Protectors212
- TST-Sweden® Hose Protection213
- TST-Sweden® Grease Remover, 0.50-Liter213
- Foot & Shin Guards214
- Steel Toe PVC Boots214
- Metatarsal Boots215
- Rain Suits215
- Face Shields216
- Safety Glasses216
- Hard Hats217
- Ear Plugs217
- PVC Gloves218
- Caution & Safety Tape218

STONEAGE® TOOLS

- Banshee® Tube Cleaning Nozzles219
- Barracuda® Rotary Shotgun Tools220
- 2" Badger® Self-Rotary Swivel221
- 4" Badger® Self-Rotary Swivel222
- 6" Badger® Self-Rotary Swivel223
- Gopher™ Self-Rotary Swivel224
- BJV™ Series Self-Rotary Swivel225
- Raptor™ Self-Rotary Swivel226
- Spitfire® Shotgun Swivel227
- Attack Tips™228
- OC8 Carbide Inserts229
- Sapphire Nozzles230
- Extension Nipples231

CHARTS & DIAGRAMS

- Tube Nozzle Drill Patters233

COMPANY INFORMATION

- Conditions of Sale & Warranty234-235
- Quality Assurance236

STANDARD TUBE NOZZLES

AP Style Standard Tube Nozzles feature FNPT threads to go with MNPT threaded lances, a slimline design that makes it easy to move through almost any size of tubing, and a wide range of options for precision drilled orifices. Medium Pressure (MP) and High Pressure (HP) Standard Tube Nozzles are designed to go with lances with either right or left hand Autoclave Type Medium Pressure threads, a special seating design that eliminates the requirement for gland nuts and collars, wrench flats for easy installation, and offer a wide range of options for precision drilled orifices.



PART NO.	STANDARD TUBE NOZZLES	INLET	O.D.	MAX PRESSURE
15-001-061	AFNPT STANDARD BLANK STAINLESS STEEL AP STYLE NOZZLE	1" NPT	---	12K psi (827 bar)
15-001-001	AFNPT1 STANDARD BLANK STAINLESS STEEL AP STYLE NOZZLE (GDWJ TYPE: 77103009)	1/16" NPT	0.375"	15K psi (1034 bar)
15-001-011	AFNPT2 STANDARD BLANK STAINLESS STEEL AP STYLE NOZZLE (GDWJ TYPE: 77103018)	1/8" NPT	0.468"	15K psi (1034 bar)
15-001-016	AFNPT STANDARD BLANK STAINLESS STEEL AP STYLE NOZZLE	1/8" NPT	0.500"	15K psi (1034 bar)
15-001-021	AFNPT4 STANDARD BLANK STAINLESS STEEL AP STYLE NOZZLE (GDWJ TYPE: 77103036)	1/4" NPT	0.625"	15K psi (1034 bar)
15-001-031	AFNPT5 STANDARD BLANK STAINLESS STEEL AP STYLE NOZZLE (GDWJ TYPE: 77103045)	3/8" NPT	0.875"	15K psi (1034 bar)
15-001-041	AFNPT STANDARD BLANK STAINLESS STEEL AP STYLE NOZZLE	1/2" NPT	1.000"	15K psi (1034 bar)
15-001-051	AFNPT STANDARD BLANK STAINLESS STEEL AP STYLE NOZZLE	3/4" NPT	---	15K psi (1034 bar)
16-001-001	STANDARD BLANK LEFT HAND MEDIUM PRESSURE NOZZLE	1/4" MP LH	---	20K psi (1379 bar)
16-001-101	STANDARD BLANK RIGHT HAND MEDIUM PRESSURE NOZZLE	1/4" MP RH	---	20K psi (1379 bar)
16-002-001	STANDARD BLANK LEFT HAND MEDIUM PRESSURE NOZZLE	3/8" MP LH	---	20K psi (1379 bar)
16-002-101	STANDARD BLANK RIGHT HAND MEDIUM PRESSURE NOZZLE	3/8" MP RH	---	20K psi (1379 bar)
16-003-001	STANDARD BLANK LEFT HAND MEDIUM PRESSURE NOZZLE	9/16" MP LH	---	20K psi (1379 bar)
16-003-101	STANDARD BLANK RIGHT HAND MEDIUM PRESSURE NOZZLE	9/16" MP RH	---	20K psi (1379 bar)
16-010-001	STANDARD BLANK LEFT HAND MEDIUM PRESSURE BUTTON NOZZLE	3/4" MP LH	---	20K psi (1379 bar)
16-010-101	STANDARD BLANK RIGHT HAND MEDIUM PRESSURE BUTTON NOZZLE	3/4" MP RH	---	20K psi (1379 bar)
16-011-001	STANDARD BLANK LEFT HAND HIGH PRESSURE NOZZLE	1/4" HP LH	---	40K psi (2758 bar)
16-011-101	STANDARD BLANK RIGHT HAND HIGH PRESSURE NOZZLE	1/4" HP RH	---	40K psi (2758 bar)
16-012-001	STANDARD BLANK LEFT HAND HIGH PRESSURE NOZZLE	3/8" HP LH	---	40K psi (2758 bar)
16-012-101	STANDARD BLANK RIGHT HAND HIGH PRESSURE NOZZLE	3/8" HP RH	---	40K psi (2758 bar)
16-013-001	STANDARD BLANK LEFT HAND HIGH PRESSURE NOZZLE	9/16" HP LH	---	40K psi (2758 bar)
16-013-101	STANDARD BLANK RIGHT HAND HIGH PRESSURE NOZZLE	9/16" HP RH	---	40K psi (2758 bar)

STANDARD TUBE NOZZLES w/ TUNGSTEN CARBIDE BLADE

Tungsten Carbide Tipped Tube Nozzles are to be used in rotary applications for the removal of hardened plugs in heat exchanger tubes.

We can drill at these particular angles:

- 5° forward
- 15° forward
 - 90° side
 - 45° back



PART NO.	STANDARD TUBE NOZZLES W/ TC BLADE	INLET	O.D.	MAX PRESSURE
15-029-101	STANDARD TUBE NOZZLE ASSEMBLY W/ TUNGSTEN CARBIDE BLADE	1/16" NPT	0.375"	15K psi (1034 bar)
15-029-111	STANDARD TUBE NOZZLE ASSEMBLY W/ TUNGSTEN CARBIDE BLADE (SA# CD 008-P2)	1/8" NPT	0.500"	15K psi (1034 bar)
15-029-121	STANDARD TUBE NOZZLE ASSEMBLY W/ TUNGSTEN CARBIDE BLADE (SA# CD 010-P4)	1/4" NPT	0.625"	15K psi (1034 bar)
15-029-131	STANDARD TUBE NOZZLE ASSEMBLY W/ TUNGSTEN CARBIDE BLADE	3/8" NPT	0.875"	15K psi (1034 bar)
15-029-141	STANDARD TUBE NOZZLE ASSEMBLY W/ TUNGSTEN CARBIDE BLADE	1/2" NPT	---	15K psi (1034 bar)
16-001-221	STANDARD RIGHT HAND MEDIUM PRESSURE TUBE NOZZLE ASSEMBLY W/ TUNGSTEN CARBIDE BLADE (SA# CD 006-M4)	1/4" MP RH	---	20K psi (1379 bar)
16-002-221	STANDARD RIGHT HAND MEDIUM PRESSURE TUBE NOZZLE ASSEMBLY W/ TUNGSTEN CARBIDE BLADE (SA# CD 007-M6)	3/8" MP RH	0.468"	20K psi (1379 bar)
16-003-221	STANDARD RIGHT HAND MEDIUM PRESSURE TUBE NOZZLE ASSEMBLY W/ TUNGSTEN CARBIDE BLADE (SA# CD 012-M9)	9/16" MP	0.750"	20K psi (1379 bar)

TURBO NOZZLES

Turbo Nozzles provide the most thorough cleaning of tube walls with maximum impact without streaking. These nozzles also integrate backward-facing orifices that propel them through hard deposits on the I.D. of pipes and tubes. At the same time, part of the nozzle rotates and polishes the pipes' I.D.

We offer custom flow rates for your special applications. Turbo Nozzles or Blanks are used to cap the end of the nozzles (sold separately). Parts that are worn can be replaced in the field within five minutes with a simple rebuild kit to minimize downtime.



PART NO.	TURBO NOZZLES	INLET	MAX PRESSURE
15-059-001	TURBO NOZZLE ASSEMBLY, #1 FLOW RATE BODY & SLEEVE	5/16"-24 MMS	4.0 GPM @ 10K psi (689 bar) 5.1 GPM @ 15K psi (1034 bar)
15-060-001	TURBO NOZZLE ASSEMBLY, #1 FLOW RATE BODY & SLEEVE	1/16" NPT	--
15-061-001	TURBO NOZZLE ASSEMBLY, #1 FLOW RATE BODY & SLEEVE	1/8" NPT	5.4 GPM @ 10K psi (689 bar) 7 GPM @ 15K psi (1034 bar)
15-062-001	TURBO NOZZLE ASSEMBLY, #1 FLOW RATE BODY & SLEEVE	1/4" NPT	5.4 GPM @ 10K psi (689 bar) 7.2 GPM @ 15K psi (1034 bar)
15-063-001	TURBO NOZZLE ASSEMBLY, #1 FLOW RATE BODY & SLEEVE	3/8" NPT	7.7 GPM @ 10K psi (689 bar) 10.1 GPM @ 15K psi (1034 bar)
15-064-001	TURBO NOZZLE ASSEMBLY, #1 FLOW RATE BODY & SLEEVE	1/2" NPT	6.1 GPM @ 10K psi (689 bar) 9.7 GPM @ 15K psi (1034 bar)
15-070-001	TURBO NOZZLE ASSEMBLY, #1 FLOW RATE BODY & SLEEVE (J/S TYPE: 52018)	1/4" MP RH	3.8 GPM @ 20K psi (1379 bar)
15-071-001	TURBO NOZZLE ASSEMBLY, #1 FLOW RATE BODY & SLEEVE (J/S TYPE: 52021)	3/8" MP RH	5.7 GPM @ 20K psi (1379 bar)
15-072-001	TURBO NOZZLE ASSEMBLY, #1 FLOW RATE BODY & SLEEVE	9/16" MP RH	8.5 GPM @ 20K psi (1379 bar)

MULTI-GROOVE NOZZLES

High Production Stainless Steel Multi-Groove Nozzles come in pressure ratings to match your flex or rigid lances. Multi-Groove Nozzles feature FNPT threads to go with MNPT threaded lances. Multi-Groove Nozzles have wrench flats for easy installation on the lance and offer many options for up to four rows of precision drilled orifices.

Please specify drilling pattern, pressure and flow when ordering.

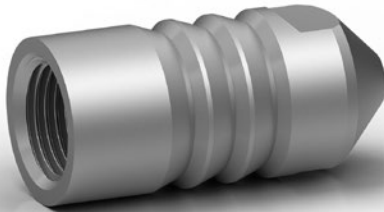

PART NO.	MULTI-GROOVE NOZZLES	INLET	O.D.	MAX PRESSURE
15-003-001	MULTI-GROOVE FNPT BLANK NOZZLE	1/16" NPT	--	15K psi (1034 bar)
15-003-011	MULTI-GROOVE FNPT BLANK NOZZLE	1/8" NPT	--	15K psi (1034 bar)
15-003-021	MULTI-GROOVE FNPT BLANK NOZZLE	1/4" NPT	--	15K psi (1034 bar)
15-003-031	MULTI-GROOVE FNPT BLANK NOZZLE	3/8" NPT	--	15K psi (1034 bar)
15-003-041	MULTI-GROOVE FNPT BLANK NOZZLE	1/2" NPT	--	15K psi (1034 bar)

FNPT NOZZLES

FNPT Nozzles are to be used in rotary applications for the removal of hardened plugs in heat exchanger tubes. FNPT Nozzle NPT threads go with lances with MNPT threads, and the slimline design makes it easy to move through almost any size of tubing. There are also a wide range of options for precision drilled orifices.



PART NO.	FNPT NOZZLES	INLET	O.D.	MAX PRESSURE
15-002-001	FNPT1 BLANK NOZZLE	1/16" NPT	--	15K psi (1034 bar)
15-002-011	FNPT2 BLANK NOZZLE	1/8" NPT	--	15K psi (1034 bar)
15-002-021	FNPT4 BLANK STAINLESS STEEL NOZZLE	1/4" NPT	--	15K psi (1034 bar)
15-002-031	FNPT5 BLANK STAINLESS STEEL NOZZLE	3/8" NPT	--	15K psi (1034 bar)
15-002-041	FNPT6 BLANK STAINLESS STEEL NOZZLE	1/2" NPT	--	15K psi (1034 bar)

BUTTON TIP FLEX LANCE NOZZLES

Button Tip compact stainless steel nozzles come in pressure ratings to match your flex lances. They are ideal for cleaning small diameter tubes with small radius bends. Button Tip Flex Lance Nozzles feature FNPT threads to go with lances with MNPT threads, and all offer many options for precision drilled orifices.



PART NO.	BUTTON TIP FLEX LANCE NOZZLES	INLET	O.D.	MAX PRESSURE
15-004-051	BUTTON TIP FNPT BLANK NOZZLE	3/4" NPT	--	12K psi (827 bar)
15-004-001	BUTTON TIP FNPT BLANK STAINLESS STEEL NOZZLE (J/S TYPE: FPC1)	1/16" NPT	--	15K psi (1034 bar)
15-004-011	BUTTON TIP FNPT BLANK STAINLESS STEEL NOZZLE (J/S TYPE: FPC3)	1/8" NPT	--	15K psi (1034 bar)
15-004-021	BUTTON TIP FNPT BLANK STAINLESS STEEL NOZZLE (J/S TYPE: FCP4)	1/4" NPT	--	15K psi (1034 bar)
15-004-031	BUTTON TIP FNPT BLANK NOZZLE (J/S TYPE: FCP5)	3/8" NPT	--	15K psi (1034 bar)
15-004-041	BUTTON TIP FNPT BLANK NOZZLE	1/2" NPT	--	15K psi (1034 bar)
16-007-001	BUTTON TIP LEFT HAND MEDIUM PRESSURE BLANK NOZZLE	1/4" MP LH	--	20K psi (1379 bar)
16-007-101	BUTTON TIP RIGHT HAND MEDIUM PRESSURE BLANK NOZZLE	1/4" MP RH	--	20K psi (1379 bar)
16-008-001	BUTTON TIP LEFT HAND MEDIUM PRESSURE BLANK NOZZLE	3/8" MP LH	--	20K psi (1379 bar)
16-008-101	BUTTON TIP RIGHT HAND MEDIUM PRESSURE BLANK NOZZLE	3/8" MP RH	--	20K psi (1379 bar)
16-009-001	BUTTON TIP LEFT HAND MEDIUM PRESSURE BLANK NOZZLE	9/16" MP LH	--	20K psi (1379 bar)
16-009-101	BUTTON TIP RIGHT HAND MEDIUM PRESSURE BLANK NOZZLE	9/16" MP RH	--	20K psi (1379 bar)
16-014-001	BUTTON TIP LEFT HAND HIGH PRESSURE BLANK NOZZLE	1/4" HP LH	--	40K psi (2758 bar)
16-014-101	BUTTON TIP RIGHT HAND HIGH PRESSURE BLANK NOZZLE	1/4" HP RH	--	40K psi (2758 bar)
16-015-001	BUTTON TIP LEFT HAND HIGH PRESSURE BLANK NOZZLE	3/8" HP LH	--	40K psi (2758 bar)
16-015-101	BUTTON TIP RIGHT HAND HIGH PRESSURE BLANK NOZZLE	3/8" HP RH	--	40K psi (2758 bar)
16-016-001	BUTTON TIP LEFT HAND HIGH PRESSURE BLANK NOZZLE	9/16" HP LH	--	40K psi (2758 bar)
16-016-101	BUTTON TIP RIGHT HAND HIGH PRESSURE BLANK NOZZLE	9/16" HP RH	--	40K psi (2758 bar)

BUTTON TIP TUBE CLEANING NOZZLES

Tube Cleaning Nozzles use high performance sapphire insert assemblies, are made of hardened stainless steel, and are ideal for most Ultra High Pressure (UHP) rigid lance tube cleaning applications. Each requires the use of an “ADMAC style” brass button (*Part No. 17-000-000*) to attach to the rigid lance.



PART NO.	BUTTON TIP TUBE CLEANING NOZZLES	INLET	O.D.	LENGTH	MAX PRESSURE
17-012-001	TUBE CLEANING NOZZLE W/ SAPPHIRE INSERT (3 JETS: 2 @ 20° INC. FWD., 1 @ 0° FORWARD)	7/16"-20 UH MBE	0.550"	--	45K psi (3103 bar)
17-012-002	TUBE CLEANING NOZZLE W/ SAPPHIRE INSERT (2 JETS @ 30° INC. FORWARD)	7/16"-20 UH MBE	0.550"	--	45K psi (3103 bar)
17-012-003	TUBE CLEANING NOZZLE W/ SAPPHIRE INSERT (2 JETS @ 20° INC. FORWARD)	7/16"-20 UH MBE	0.550"	--	45K psi (3103 bar)
17-012-004	TUBE CLEANING NOZZLE W/ SAPPHIRE INSERT (3 JETS: 2 @ 30° INC. FWD, 1 @ 0° FORWARD)	7/16"-20 UH MBE	0.550"	--	45K psi (3103 bar)
17-012-005	TUBE CLEANING NOZZLE W/ SAPPHIRE INSERT (2 JETS @ 45° INC. FORWARD)	7/16"-20 UH MBE	0.550"	--	45K psi (3103 bar)
17-012-006	TUBE CLEANING NOZZLE W/ CARBIDE BLADE (2 JETS @ 45° INC. FORWARD)	7/16"-20 UH MBE	0.550"	--	45K psi (3103 bar)
17-012-007	TUBE CLEANING NOZZLE W/ CARBIDE BLADE (3 JETS: 2 @ 45° INC. FWD., 1 @ 0° FORWARD)	7/16"-20 UH MBE	0.550"	--	45K psi (3103 bar)
17-012-008	TUBE CLEANING NOZZLE W/ SAPPHIRE INSERT (4 JETS @ 30° INC. FORWARD)	7/16"-20 UH MBE	0.650"	--	45K psi (3103 bar)
17-012-009	RAPER CLEANING NOZZLE W/ SAPPHIRE INSERT (4 JETS: 2 @ 30° INC. FORWARD, 2 @ 150° INC.)	7/16"-20 UH MBE	0.650"	--	45K psi (3103 bar)
17-012-010	TUBE CLEANING NOZZLE W/ SAPPHIRE INSERT (2 JETS @ 30° INC. FORWARD)	7/16"-20 UH MBE	0.650"	--	45K psi (3103 bar)
17-014-001	SURFACE CLEANING NOZZLE W/ SAPPHIRE INSERT (3 JETS @ 15° INC. FORWARD)	9/16"-18 UHF	0.875"	1.000"	45K psi (3103 bar)
17-014-002	SURFACE CLEANING NOZZLE W/ SAPPHIRE INSERT (2 JETS @ 20° INC. FORWARD)	9/16"-18 UHF	0.875"	1.000"	45K psi (3103 bar)
17-014-003	TUBE CLEANING NOZZLE W/ SAPPHIRE INSERT (2 JETS @ 20° INC. FORWARD)	9/16"-18 UHF	0.875"	1.000"	45K psi (3103 bar)
17-014-004	TUBE CLEANING NOZZLE W/ SAPPHIRE INSERT (4 JETS @ 20° INC. FORWARD)	9/16"-18 UHF	0.875"	1.000"	45K psi (3103 bar)
17-014-005	SURFACE CLEANING NOZZLE W/ SAPPHIRE INSERT (4 JETS @ 20° INC. FORWARD)	9/16"-18 UHF	0.875"	1.000"	45K psi (3103 bar)
17-014-006	SURFACE CLEANING NOZZLE W/ SAPPHIRE INSERT (4 JETS @ 30° INC. FORWARD)	9/16"-18 UHF	0.875"	1.000"	45K psi (3103 bar)
17-014-007	SURFACE CLEANING NOZZLE W/ SAPPHIRE INSERT (4 JETS @ 45° INC. FORWARD)	9/16"-18 UHF	0.875"	1.000"	45K psi (3103 bar)

BUTTON TIP TUBE CLEANING NOZZLES

(Continued)

PART NO.	BUTTON TIP TUBE CLEANING NOZZLES	INLET	O.D.	LENGTH	MAX PRESSURE
17-014-008	TUBE CLEANING NOZZLE W/ SAPPHIRE INSERT (2 JETS @ 60° INC. FORWARD)	9/16"-18 UHF	0.875"	1.000"	45K psi (3103 bar)
17-014-009	TUBE CLEANING NOZZLE W/ SAPPHIRE INSERT (4 JETS @ 60° INC. FORWARD)	9/16"-18 UHF	0.875"	1.000"	45K psi (3103 bar)
17-014-010	TUBE CLEANING NOZZLE W/ SAPPHIRE INSERT (4 JETS @ 45° INC. FORWARD)	9/16"-18 UHF	0.875"	1.000"	45K psi (3103 bar)
17-014-011	TUBE CLEANING NOZZLE W/ SAPPHIRE INSERT (4 JETS: 2 @ 60° INC. FORWARD, 2 @ 10° BACK)	9/16"-18 UHF	0.875"	1.000"	45K psi (3103 bar)
17-014-015	TUBE CLEANING NOZZLE W/ SAPPHIRE INSERT (4 JETS: 2 @ 60° FORWARD, INC. 2 @ 10° BACK)	9/16"-18 UHF	0.875"	2.500"	45K psi (3103 bar)
17-014-016	TUBE CLEANING NOZZLE W/ SAPPHIRE INSERT (2 SIDE JETS @ 90°)	9/16"-18 UHF	1.000"	1.500"	45K psi (3103 bar)
17-014-017	TUBE CLEANING NOZZLE W/ SAPPHIRE INSERT (4 SIDE JETS @ 90°)	9/16"-18 UHF	1.000"	1.500"	45K psi (3103 bar)
17-014-018	TUBE CLEANING NOZZLE W/ SAPPHIRE INSERT (2 SIDE JETS @ 80°)	9/16"-18 UHF	1.000"	1.500"	45K psi (3103 bar)
17-014-019	TUBE CLEANING NOZZLE W/ SAPPHIRE INSERT (4 SIDE JETS @ 80°)	9/16"-18 UHF	1.000"	1.500"	45K psi (3103 bar)
17-014-020	TUBE CLEANING NOZZLE W/ SAPPHIRE INSERT (4 JETS: 2 @ 40° INC. FWD., 2 @ 60° INC. FORWARD)	9/16"-18 UHF	1.000"	2.000"	45K psi (3103 bar)
17-014-021	SNAKE CLEANING NOZZLE W/ SAPPHIRE INSERT (4 JETS: 3 @ 30° INC. FWD., 1 @ 5° FORWARD)	9/16"-18 UHF	1.000"	3.000"	45K psi (3103 bar)
17-014-022	TUBE CLEANING NOZZLE W/ SAPPHIRE INSERT (2 BACK JETS @ 160°)	9/16"-18 HP FAC	1.000"	1.500"	40K psi (2758 bar)
17-014-023	TUBE CLEANING NOZZLE W/ SAPPHIRE INSERT (4 BACK JETS @ 160°)	9/16"-18 HP FAC	1.000"	1.500"	40K psi (2758 bar)
17-014-024	TUBE CLEANING NOZZLE W/ SAPPHIRE INSERT (2 BACK JETS @ 180°)	9/16"-18 HP FAC	1.000"	1.500"	40K psi (2758 bar)
17-014-025	TUBE CLEANING NOZZLE W/ SAPPHIRE INSERT (4 BACK JETS @ 180°)	9/16"-18 HP FAC	1.000"	1.500"	40K psi (2758 bar)
17-014-026	TUBE CLEANING NOZZLE W/ SAPPHIRE INSERT (2 BACK JETS @ 200°)	9/16"-18 HP FAC	1.000"	1.500"	40K psi (2758 bar)
17-014-027	TUBE CLEANING NOZZLE W/ SAPPHIRE INSERT (4 BACK JETS @ 200°)	9/16"-18 HP FAC	1.000"	1.500"	40K psi (2758 bar)
17-014-028	TUBE CLEANING NOZZLE W/ SAPPHIRE INSERT (6 JETS @ 60° INC. FORWARD)	9/16"-18 HP FAC	1.500"	2.500"	40K psi (2758 bar)
17-014-029	TUBE CLEANING NOZZLE W/ SAPPHIRE INSERT (5 JETS: 1 @ 0°, 2 @ 90° INC, 2 REAR 135° NOT INC.)	9/16"-18 HP FAC	0.875"	2.500"	40K psi (2758 bar)
17-014-030	TUBE CLEANING NOZZLE W/ SAPPHIRE INSERT (4 JETS: 2 FORWARD @ 90° INC., 2 REAR @ 135° NOT INC.)	9/16"-18 UHF	0.875"	2.000"	40K psi (2758 bar)
17-014-031	TUBE CLEANING NOZZLE W/ SAPPHIRE INSERT (2 JETS @ 60° INC. FORWARD)	9/16"-18 UHF	1.000"	3.000"	40K psi (2758 bar)
17-014-032	TUBE CLEANING NOZZLE W/ SAPPHIRE INSERT (2 JETS @ 20° INC. FORWARD)	9/16"-18 UHF	1.125"	3.000"	40K psi (2758 bar)
17-014-033	TUBE CLEANING NOZZLE W/ SAPPHIRE INSERT (2 JETS @ 20° INC. FORWARD)	9/16"-18 UHF	0.875"	3.000"	40K psi (2758 bar)
17-014-034	TUBE CLEANING NOZZLE W/ SAPPHIRE INSERT (6 JETS: 2 FORWARD @ 20° INC., 2 BACK @ 40°, 2 BACK @ 60°)	9/16"-18 UHF	0.875"	2.000"	40K psi (2758 bar)
17-014-035	TUBE CLEANING NOZZLE W/ SAPPHIRE INSERT (4 JETS: 2 FORWARD @ 90° INC., 2 JETS BACK @ 45°)	9/16"-18 UHF	1.000"	2.000"	40K psi (2758 bar)

TLX NOZZLES

Stainless Steel TLX Nozzles come in pressure ratings to match your flex or rigid lances. TLX Nozzles feature FNPT threads to go with lances with MNPT threads, 20K psi TLX Nozzles have Autoclave-type MP threads, and the 40K psi TLX Nozzles have autoclave-type HP threads. All have wrench flats for easy installation on the lance and offer many options for 3 or 4 rows of precision drilled orifices.



PART NO.	TLX NOZZLES	INLET	O.D.	MAX PRESSURE
15-007-001	BLANK TLX NOZZLE	1/16" NPT	0.375"	15K psi (1034 bar)
15-007-011	BLANK TLX NOZZLE	1/8" NPT	0.468"	15K psi (1034 bar)
15-007-021	BLANK TLX NOZZLE	1/4" NPT	0.625"	15K psi (1034 bar)
15-007-031	BLANK TLX NOZZLE	3/8" NPT	0.875"	15K psi (1034 bar)
15-007-041	BLANK TLX NOZZLE	1/2" NPT	1.000"	15K psi (1034 bar)
15-007-051	BLANK STAINLESS STEEL TLX NOZZLE	3/4" NPT	--	15K psi (1034 bar)
16-004-001	BLANK TLX NOZZLE	1/4" MP LH	--	20K psi (1379 bar)
16-004-101	BLANK TLX NOZZLE	1/4" MP RH	--	20K psi (1379 bar)
16-005-001	BLANK TLX NOZZLE	3/8" MP LH	--	20K psi (1379 bar)
16-005-101	BLANK TLX NOZZLE	3/8" MP RH	--	20K psi (1379 bar)
16-006-001	BLANK TLX NOZZLE	9/16" MP LH	--	20K psi (1379 bar)
16-006-101	BLANK TLX NOZZLE	9/16" MP RH	--	20K psi (1379 bar)
16-017-001	BLANK TLX NOZZLE	1/4" HP LH	--	40K psi (2758 bar)
16-017-101	BLANK TLX NOZZLE	1/4" HP RH	--	40K psi (2758 bar)
16-018-001	BLANK TLX NOZZLE	3/8" HP LH	--	40K psi (2758 bar)
16-018-101	BLANK TLX NOZZLE	3/8" HP RH	--	40K psi (2758 bar)
16-019-001	BLANK TLX NOZZLE	9/16" HP LH	--	40K psi (2758 bar)
16-019-101	BLANK TLX NOZZLE	9/16" HP RH	--	40K psi (2758 bar)

THRUSTER NOZZLES

Stainless Steel Thruster Nozzles are used with flex lances in conjunction with another tube cleaning nozzle. They allow one to “stack” the nozzles so that additional jets can be used for a more thorough cleaning.



PART NO.	THRUSTER NOZZLES	INLET	O.D.	MAX PRESSURE
15-101-061	BLANK NOZZLE THRUSTER	1" NPT (M X F)	--	12K psi (827 bar)
15-101-001	BLANK NOZZLE THRUSTER	1/16" NPT (M X F)	--	15K psi (1034 bar)
15-101-011	BLANK NOZZLE THRUSTER	1/8" NPT (M X F)	--	15K psi (1034 bar)
15-101-021	BLANK NOZZLE THRUSTER	1/4" NPT (M X F)	--	15K psi (1034 bar)
15-101-031	BLANK NOZZLE THRUSTER	3/8" NPT (M X F)	--	15K psi (1034 bar)
15-101-041	BLANK NOZZLE THRUSTER	1/2" NPT (M X F)	--	15K psi (1034 bar)
15-101-051	BLANK NOZZLE THRUSTER	3/4" NPT (M X F)	--	15K psi (1034 bar)

MONRO-JET ORBITAL NOZZLES

Monro-Jet Orbital Nozzles offer the hard hitting capability of the straight jet with the wider path of the fan jet and are available up to 40K psi (2800 bar). Metric and U.S. connections are available, allowing for installation on to lances, guns, and remotely controlled equipment.



PART NO.	MONRO-JET ORBITAL NOZZLES	INLET	O.D.	MAX PRESSURE
15-200-031	MONRO-JET, F2 0.0314" / 0.800MM ORIFICE	1/2" NPT	--	14.5K psi (1000 bar)
15-200-033	MONRO-JET, F2 0.0330" / 0.850MM ORIFICE	1/2" NPT	--	14.5K psi (1000 bar)
15-200-037	MONRO-JET, F2 0.0374" / 0.950MM ORIFICE	1/2" NPT	--	14.5K psi (1000 bar)
15-200-039	MONRO-JET, F2 0.0390" / 1.000MM ORIFICE	1/2" NPT	--	4.6 GPM @ 15K psi (1034 bar)
15-200-041	MONRO-JET, F2 0.0413" / 1.050MM ORIFICE	1/2" NPT	--	14.5K psi (1000 bar)
15-200-043	MONRO-JET, F2 0.0430" / 1.100MM ORIFICE	1/2" NPT	--	14.5K psi (1000 bar)
15-200-045	MONRO-JET, F2 0.0450" / 1.150MM ORIFICE	1/2" NPT	--	14.5K psi (1000 bar)
15-200-047	MONRO-JET, F2 0.0470" / 1.200MM ORIFICE	1/2" NPT	--	14.5K psi (1000 bar)
15-200-049	MONRO-JET, F2 0.0490" / 1.250MM ORIFICE	1/2" NPT	--	14.5K psi (1000 bar)
15-200-051	MONRO-JET, F2 0.0510" / 1.300MM ORIFICE	1/2" NPT	--	8.55 GPM @ 14.5K psi (1000 bar)
15-200-053	MONRO-JET, F2 0.0530" / 1.350MM ORIFICE	1/2" NPT	--	14.5K psi (1000 bar)
15-200-055	MONRO-JET, F2 0.0550" / 1.400MM ORIFICE	1/2" NPT	--	14.5K psi (1000 bar)
16-200-024	MONRO-JET, F1 0.024" / 0.60MM ORIFICE	9/16"-18 LH	--	2.0 GPM @ 20K psi (1379 bar)
16-200-026	MONRO-JET, F1 0.026" / 0.65MM ORIFICE	9/16"-18 LH	--	2.5 GPM @ 20K psi (1379 bar)
16-200-028	MONRO-JET, F1 0.028" / 0.70MM ORIFICE	9/16"-18 LH	--	2.9 GPM @ 20K psi (1379 bar)
16-200-030	MONRO-JET, F1 0.0295" / 0.75MM ORIFICE	9/16"-18 LH	--	3.3 GPM @ 20K psi (1379 bar)
16-200-031	MONRO-JET, F1 0.031" / 0.80MM ORIFICE	9/16"-18 LH	--	3.7 GPM @ 20K psi (1379 bar)
16-200-033	MONRO-JET, F1 0.033" / 0.85MM ORIFICE	9/16"-18 LH	--	4.2 GPM @ 20K psi (1379 bar)
16-200-035	MONRO-JET, F1 0.035" / 0.90MM ORIFICE	9/16"-18 LH	--	4.7 GPM @ 20K psi (1379 bar)
16-200-037	MONRO-JET, F1 0.0374" / 0.95MM ORIFICE	9/16"-18 MP LH	--	5.3 GPM @ 20K psi (1379 bar)
16-200-039	MONRO-JET, F1 0.039" / 1.0MM ORIFICE	9/16"-18 LH	--	5.8 GPM @ 20K psi (1379 bar)
16-200-041	MONRO-JET, F1 0.041" / 1.05MM ORIFICE	9/16"-18 LH	--	6.4 GPM @ 20K psi (1379 bar)
16-200-043	MONRO-JET, F1 0.043" / 1.10MM ORIFICE	9/16"-18 MP LH	--	7.0 GPM @ 20K psi (1379 bar)
16-200-045	MONRO-JET, F1 0.045" / 1.15MM ORIFICE	9/16"-18 MP LH	--	7.7 GPM @ 20K psi (1379 bar)
16-200-047	MONRO-JET, F1 0.047" / 1.20MM ORIFICE	9/16"-18 LH	--	8.4 GPM @ 20K psi (1379 bar)
16-200-049	MONRO-JET, F1 0.049" / 1.25MM ORIFICE	9/16"-18 LH	--	9.1 GPM @ 20K psi (1379 bar)
16-200-051	MONRO-JET, F1 0.051" / 1.30MM ORIFICE	9/16"-18 LH	--	9.8 GPM @ 20K psi (1379 bar)
16-200-053	MONRO-JET, F1 0.053" / 1.35MM ORIFICE	9/16"-18 LH	--	10.6 GPM @ 20K psi (1379 bar)
16-200-055	MONRO-JET, F1 0.055" / 1.40MM ORIFICE	9/16"-18 LH	--	11.4 GPM @ 20K psi (1379 bar)
16-200-057	MONRO-JET, F1 0.057" / 1.45MM ORIFICE	9/16"-18 LH	--	12.2 GPM @ 20K psi (1379 bar)
16-200-059	MONRO-JET, F1 0.059" / 1.50MM ORIFICE	9/16"-18 LH	--	13.1 GPM @ 20K psi (1379 bar)
16-200-061	MONRO-JET, F1 0.061" / 1.55MM ORIFICE	9/16"-18 LH	--	14.0 GPM @ 20K psi (1379 bar)

MONRO-JET ORBITAL NOZZLE REPAIR KITS

The Monro-Jet Orbital Nozzle series uses an internal rotor to achieve a spinning fan jet. The repair kits above are replacement rotors for rebuilding the tool.

Additional sizes are available upon request.



PART NO.	MONRO-JET NOZZLE REPAIR KITS	INLET	O.D.	MAX PRESSURE
16-201-035	REPAIR KIT, (0.035" / 0.9MM) ORIFICE	--	--	3.544 GPM @ 10K psi (689 bar) 5.0 GPM @ 20K psi (1379 bar)
16-201-043	REPAIR KIT, (0.043" / 1.10MM) ORIFICE	--	--	4.98 GPM @ 10K psi (689 bar) 7.0 GPM @ 20K psi (1379 bar)
16-201-045	REPAIR KIT, (0.045" / 1.15MM) ORIFICE	--	--	5.44 GPM @ 10K psi (689 bar) 7.7 GPM @ 20K psi (1379 bar)
16-201-049	REPAIR KIT, F1/F2/F3/F25 (0.049" / 1.25MM) ORIFICE	--	--	6.94 GPM @ 10K psi (689 bar) 9.8 GPM @ 20K psi (1379 bar)
16-201-051	ROTOR, (0.051" / 1.30MM) ORIFICE	--	--	9.8 GPM @ 20K psi (1379 bar)
16-201-061	REPAIR KIT, F1/2/3 (0.061" / 1.55M) ORIFICE	--	--	14.0 GPM @ 20K psi (1379 bar)
16-201-063	REPAIR KIT, (0.063" / 1.60MM) ORIFICE	--	--	10.5 GPM @ 10K psi (689 bar) 14.9 GPM @ 20K psi (1379 bar)
16-201-075	REPAIR KIT, (0.075" / 1.90MM) ORIFICE	--	--	14.85 GPM @ 10K psi (689 bar) 21.0 GPM @ 20K psi (1379 bar)

PENETRATOR NOZZLES

Stainless Steel Penetrator Nozzles are used with rigid or flex lances with MNPT threads. The rounded nose shape permits a range of forward and side drilling patterns, while the backwards facing ridge allows a large number of pulling orifices to more efficiently clean fouled tubing. Wrench flats allow for easy installation.

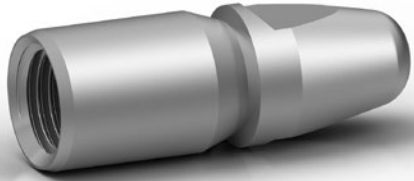

PART NO.	PENETRATOR NOZZLES	INLET	O.D.	MAX PRESSURE
15-005-001	BLANK PFNPT PENETRATOR NOZZLE	1/16" NPT	--	15K psi (1034 bar)
15-005-011	BLANK PFNPT PENETRATOR NOZZLE	1/8" NPT	--	15K psi (1034 bar)
15-005-021	BLANK PFNPT PENETRATOR NOZZLE	1/4" NPT	--	15K psi (1034 bar)
15-005-031	BLANK PFNPT PENETRATOR NOZZLE	3/8" NPT	--	15K psi (1034 bar)
15-005-041	BLANK PFNPT PENETRATOR NOZZLE	1/2" NPT	--	15K psi (1034 bar)

EVAPORATOR NOZZLES

Stainless Steel Evaporator Nozzles are used with rigid or flex lances with MNPT threads. The design permits a range of forward and side drilling patterns, while the backwards facing ridge allows a large number of pulling orifices to more efficiently clean fouled tubing. Wrench flats allow for easy installation.



PART NO.	EVAPORATOR NOZZLES	INLET	O.D.	MAX PRESSURE
15-006-001	BLANK EVNPT EVAPORATOR NOZZLE	1/16" NPT	--	15K psi (1034 bar)
15-006-011	BLANK EVNPT EVAPORATOR NOZZLE	1/8" NPT	--	15K psi (1034 bar)
15-006-021	BLANK EVNPT EVAPORATOR NOZZLE	1/4" NPT	--	15K psi (1034 bar)
15-006-031	BLANK EVNPT5 EVAPORATOR NOZZLE	3/8" NPT	--	15K psi (1034 bar)
15-006-041	BLANK EVNPT EVAPORATOR NOZZLE	1/2" NPT	--	15K psi (1034 bar)

MALE MACHINE SCREW NOZZLES

Stainless Steel MMS Nozzles come in pressure ratings to match your flex or rigid lances with female machine screw threads (UNF or UNC). The compact MMS nozzles have a special slimline design that assures that the outside diameter matches the outer diameter of the lance, and they have wrench flats for easy installation. All offer many options for three or four rows of precision drilled orifices.



PART NO.	MALE MACHINE SCREW NOZZLES	INLET	O.D.	MAX PRESSURE
15-008-000	MALE MACHINE SCREW NOZZLE BLANK	10-24 UNC	0.250"	15K psi (1034 bar)
15-008-001	MALE MACHINE SCREW-1 NOZZLE BLANK	12-28 UNF	0.250"	15K psi (1034 bar)
15-008-002	MALE MACHINE SCREW-2 NOZZLE BLANK	1/4"-28 UNF	0.312"	15K psi (1034 bar)
15-008-004	MALE MACHINE SCREW-4 NOZZLE	5/16"-18 UNC	--	15K psi (1034 bar)
15-008-005	MALE MACHINE SCREW-5 NOZZLE BLANK	3/8"-24 UNF	9/16"	15K psi (1034 bar)
15-008-006	MALE MACHINE SCREW-6 NOZZLE BLANK	1/2"-20 UNF	--	15K psi (1034 bar)
15-008-003	MALE MACHINE SCREW-3 NOZZLE BLANK	5/16"-24 UNF	0.406"	20K psi (1379 bar)

MALE MACHINE THREAD LANCE NOZZLES

Our Button-Tip Compact Stainless Steel Nozzles come in pressure ratings to match your flex lances. They are ideal for cleaning small diameter tubes with small radius bends. 40K psi Male Machine Thread Lance Nozzles have Autoclave-type HP threads and offer many options for precision drilled orifices.

Please specify drilling patterns, pressure, and flow when ordering.



PART NO.	MALE MACHINE THREAD LANCE NOZZLES	INLET	O.D.	MAX PRESSURE
16-020-001	BLANK MP/HP BUTTON NOZZLE	1/4"-28 RH MALE	--	40K psi (2758 bar)
16-020-002	BLANK MP/HP BUTTON NOZZLE	3/8"-24 RH MALE	--	40K psi (2758 bar)
16-020-003	BLANK MP/HP BUTTON NOZZLE	9/16"-18 RH MALE	--	40K psi (2758 bar)
16-020-004	BLANK MP/HP BUTTON NOZZLE	1/4"-28 LH MALE	--	40K psi (2758 bar)
16-020-005	BLANK MP/HP BUTTON NOZZLE	3/8"-24 LH MALE	--	40K psi (2758 bar)
16-020-006	BLANK MP/HP BUTTON NOZZLE	9/16"-18 LH MALE	--	40K psi (2758 bar)
16-020-007	BLANK MP/HP BUTTON NOZZLE	10-32 RH MALE	0.250"	40K psi (2758 bar)
16-020-010	SHORT BLANK STAINLESS STEEL MP/HP BUTTON NOZZLE	1/4"-28 HP RH MALE	--	40K psi (2758 bar)

1/4"-28 RH HP TESTED SAPPHIRE ORIFICE ASSEMBLIES

High Performance (HP) Sapphire Nozzle Assemblies are compact inserts made to screw in to the most typical Ultra High Pressure (UHP) rotary nozzle holder bodies common to the UHP cleaning applications.

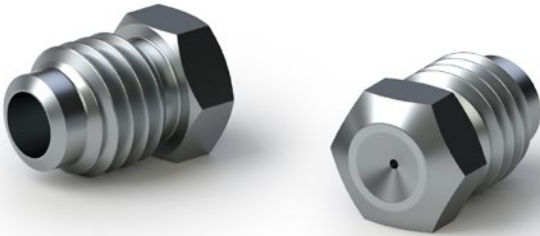

PART NO.	1/4"-28 RH HP TESTED SAPPHIRE ORIFICE ASSEMBLIES	INLET	MAX PRESSURE
17-022-000	COHESIVE STYLE PLUG	1/4"-28 RH (1/4" MALE HEX)	40K psi (2758 bar)
17-022-013	0.013" COHESIVE TESTED SAPPHIRE ORIFICE ASSEMBLY	1/4"-28 RH (1/4" MALE HEX)	40K psi (2758 bar)
17-022-014	0.014" COHESIVE TESTED SAPPHIRE ORIFICE ASSEMBLY	1/4"-28 RH (1/4" MALE HEX)	40K psi (2758 bar)
17-022-015	0.015" COHESIVE TESTED SAPPHIRE ORIFICE ASSEMBLY	1/4"-28 RH (1/4" MALE HEX)	40K psi (2758 bar)
17-022-017	0.017" COHESIVE TESTED SAPPHIRE ORIFICE ASSEMBLY	1/4"-28 RH (1/4" MALE HEX)	40K psi (2758 bar)
17-022-018	0.018" COHESIVE TESTED SAPPHIRE ORIFICE ASSEMBLY	1/4"-28 RH (1/4" MALE HEX)	40K psi (2758 bar)
17-022-019	0.019" COHESIVE TESTED SAPPHIRE ORIFICE ASSEMBLY	1/4"-28 RH (1/4" MALE HEX)	40K psi (2758 bar)
17-022-020	0.020" COHESIVE TESTED SAPPHIRE ORIFICE ASSEMBLY	1/4"-28 RH (1/4" MALE HEX)	40K psi (2758 bar)
17-022-021	0.021" COHESIVE TESTED SAPPHIRE ORIFICE ASSEMBLY	1/4"-28 RH (1/4" MALE HEX)	40K psi (2758 bar)
17-022-022	0.022" COHESIVE TESTED SAPPHIRE ORIFICE ASSEMBLY	1/4"-28 RH (1/4" MALE HEX)	40K psi (2758 bar)
17-022-023	0.023" COHESIVE TESTED SAPPHIRE ORIFICE ASSEMBLY	1/4"-28 RH (1/4" MALE HEX)	40K psi (2758 bar)
17-022-024	0.024" COHESIVE TESTED SAPPHIRE ORIFICE ASSEMBLY	1/4"-28 RH (1/4" MALE HEX)	40K psi (2758 bar)
17-022-025	0.025" COHESIVE TESTED SAPPHIRE ORIFICE ASSEMBLY	1/4"-28 RH (1/4" MALE HEX)	40K psi (2758 bar)
17-022-026	0.026" COHESIVE TESTED SAPPHIRE ORIFICE ASSEMBLY	1/4"-28 RH (1/4" MALE HEX)	40K psi (2758 bar)
17-022-027	0.027" COHESIVE TESTED SAPPHIRE ORIFICE ASSEMBLY	1/4"-28 RH (1/4" MALE HEX)	40K psi (2758 bar)
17-022-028	0.028" COHESIVE TESTED SAPPHIRE ORIFICE ASSEMBLY	1/4"-28 RH (1/4" MALE HEX)	40K psi (2758 bar)
17-022-029	0.029" COHESIVE TESTED SAPPHIRE ORIFICE ASSEMBLY	1/4"-28 RH (1/4" MALE HEX)	40K psi (2758 bar)
17-022-030	0.030" COHESIVE TESTED SAPPHIRE ORIFICE ASSEMBLY	1/4"-28 RH (1/4" MALE HEX)	40K psi (2758 bar)
17-022-032	0.032" COHESIVE TESTED SAPPHIRE ORIFICE ASSEMBLY	1/4"-28 RH (1/4" MALE HEX)	40K psi (2758 bar)
17-022-033	0.033" COHESIVE TESTED SAPPHIRE ORIFICE ASSEMBLY	1/4"-28 RH (1/4" MALE HEX)	40K psi (2758 bar)
17-022-034	0.034" COHESIVE TESTED SAPPHIRE ORIFICE ASSEMBLY	1/4"-28 RH (1/4" MALE HEX)	40K psi (2758 bar)
17-022-035	0.035" COHESIVE TESTED SAPPHIRE ORIFICE ASSEMBLY	1/4"-28 RH (1/4" MALE HEX)	40K psi (2758 bar)
17-022-038	0.038" COHESIVE TESTED SAPPHIRE ORIFICE ASSEMBLY	1/4"-28 RH (1/4" MALE HEX)	40K psi (2758 bar)
17-022-040	0.040" COHESIVE TESTED SAPPHIRE ORIFICE ASSEMBLY	1/4"-28 RH (1/4" MALE HEX)	40K psi (2758 bar)

1/4"-28 RH HP STAT-TESTED SAPPHIRE ORIFICE ASSEMBLIES

These High Performance Sapphire Nozzle Assemblies are designed to be used with many typical UHP rotary nozzle holder bodies used in the most demanding cleaning applications.

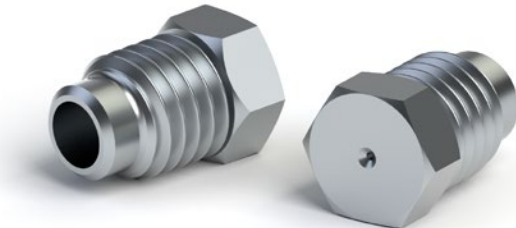

PART NO.	1/4"-28 RH HP STAT-TESTED SAPPHIRE ORIFICE ASSEMBLIES	INLET	MAX PRESSURE
17-016-000	SAPPHIRE ORIFICE PLUG	1/4"-28 RH HP	40K psi (2758 bar)
17-016-010	0.010" STAT-TESTED SAPPHIRE ORIFICE ASSEMBLY (OS4 010)	1/4"-28 RH HP	40K psi (2758 bar)
17-016-012	0.012" STAT-TESTED SAPPHIRE ORIFICE ASSEMBLY (OS4 012)	1/4"-28 RH HP	40K psi (2758 bar)
17-016-013	0.013" STAT-TESTED SAPPHIRE ORIFICE ASSEMBLY	1/4"-28 RH HP	40K psi (2758 bar)
17-016-014	0.014" STAT-TESTED SAPPHIRE ORIFICE ASSEMBLY (OS4 014)	1/4"-28 RH HP	40K psi (2758 bar)
17-016-015	0.015" STAT-TESTED SAPPHIRE ORIFICE ASSEMBLY (OS4 015)	1/4"-28 RH HP	40K psi (2758 bar)
17-016-016	0.016" STAT-TESTED SAPPHIRE ORIFICE ASSEMBLY (OS4 016)	1/4"-28 RH HP	40K psi (2758 bar)
17-016-017	0.017" STAT-TESTED SAPPHIRE ORIFICE ASSEMBLY	1/4"-28 RH HP	40K psi (2758 bar)
17-016-018	0.018" STAT-TESTED SAPPHIRE ORIFICE ASSEMBLY	1/4"-28 RH HP	40K psi (2758 bar)
17-016-019	0.019" STAT-TESTED SAPPHIRE ORIFICE ASSEMBLY	1/4"-28 RH HP	40K psi (2758 bar)
17-016-020	0.020" STAT-TESTED SAPPHIRE ORIFICE ASSEMBLY	1/4"-28 RH HP	40K psi (2758 bar)
17-016-021	0.021" STAT-TESTED SAPPHIRE ORIFICE ASSEMBLY	1/4"-28 RH HP	40K psi (2758 bar)
17-016-022	0.022" STAT-TESTED SAPPHIRE ORIFICE ASSEMBLY (OS4 022)	1/4"-28 RH HP	40K psi (2758 bar)
17-016-023	0.023" STAT-TESTED SAPPHIRE ORIFICE ASSEMBLY	1/4"-28 RH HP	40K psi (2758 bar)
17-016-024	0.024" STAT-TESTED SAPPHIRE ORIFICE ASSEMBLY	1/4"-28 RH HP	40K psi (2758 bar)
17-016-025	0.025" STAT-TESTED SAPPHIRE ORIFICE ASSEMBLY	1/4"-28 RH HP	40K psi (2758 bar)
17-016-026	0.026" STAT-TESTED SAPPHIRE ORIFICE ASSEMBLY	1/4"-28 RH HP	40K psi (2758 bar)
17-016-027	0.027" STAT-TESTED SAPPHIRE ORIFICE ASSEMBLY	1/4"-28 RH HP	40K psi (2758 bar)
17-016-028	0.028" STAT-TESTED SAPPHIRE ORIFICE ASSEMBLY	1/4"-28 RH HP	40K psi (2758 bar)
17-016-029	0.029" STAT-TESTED SAPPHIRE ORIFICE ASSEMBLY	1/4"-28 RH HP	40K psi (2758 bar)
17-016-030	0.030" STAT-TESTED SAPPHIRE ORIFICE ASSEMBLY	1/4"-28 RH HP	40K psi (2758 bar)
17-016-031	0.031" STAT-TESTED SAPPHIRE ORIFICE ASSEMBLY (OS4 031)	1/4"-28 RH HP	40K psi (2758 bar)
17-016-032	0.032" STAT-TESTED SAPPHIRE ORIFICE ASSEMBLY (OS4 032)	1/4"-28 RH HP	40K psi (2758 bar)
17-016-033	0.033" STAT-TESTED SAPPHIRE ORIFICE ASSEMBLY	1/4"-28 RH HP	40K psi (2758 bar)
17-016-034	0.034" STAT-TESTED SAPPHIRE ORIFICE ASSEMBLY	1/4"-28 RH HP	40K psi (2758 bar)
17-016-035	0.035" STAT-TESTED SAPPHIRE ORIFICE ASSEMBLY (OS4 035)	1/4"-28 RH HP	40K psi (2758 bar)
17-016-036	0.036" STAT-TESTED SAPPHIRE ORIFICE ASSEMBLY	1/4"-28 RH HP	40K psi (2758 bar)
17-016-037	0.037" STAT-TESTED SAPPHIRE ORIFICE ASSEMBLY	1/4"-28 RH HP	40K psi (2758 bar)
17-016-038	0.038" STAT-TESTED SAPPHIRE ORIFICE ASSEMBLY	1/4"-28 RH HP	40K psi (2758 bar)
17-016-039	0.039" STAT-TESTED SAPPHIRE ORIFICE ASSEMBLY	1/4"-28 RH HP	40K psi (2758 bar)
17-016-040	0.040" STAT-TESTED SAPPHIRE ORIFICE ASSEMBLY	1/4"-28 RH HP	40K psi (2758 bar)

3/8"-24 RH HP STAT-TESTED SAPPHIRE ORIFICE ASSEMBLIES

High-Performance Sapphire Nozzle Assemblies are compact inserts made to screw in to the most typical UHP rotary nozzles holder bodies common to UHP cleaning applications.

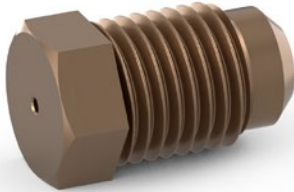

PART NO.	3/8"-24 RH HP STAT-TESTED SAPPHIRE ORIFICE ASSEMBLIES	INLET	MAX PRESSURE
17-002-000	PATENTED SAPPHIRE ORIFICE PLUG (OS6-PLUG)	3/8"-24	40K psi (2758 bar)
17-002-007	0.007" STAT-TESTED SAPPHIRE ORIFICE ASSEMBLY	3/8"-24 RH HP	40K psi (2758 bar)
17-002-008	0.008" STAT-TESTED SAPPHIRE ORIFICE ASSEMBLY	3/8"-24 RH HP	40K psi (2758 bar)
17-002-009	0.009" STAT-TESTED SAPPHIRE ORIFICE ASSEMBLY	3/8"-24 RH HP	40K psi (2758 bar)
17-002-010	0.010" STAT-TESTED SAPPHIRE ORIFICE ASSEMBLY	3/8"-24 RH HP	40K psi (2758 bar)
17-002-011	0.011" STAT-TESTED SAPPHIRE ORIFICE ASSEMBLY	3/8"-24 RH HP	40K psi (2758 bar)
17-002-012	0.012" STAT-TESTED SAPPHIRE ORIFICE ASSEMBLY	3/8"-24 RH HP	40K psi (2758 bar)
17-002-013	0.013" STAT-TESTED SAPPHIRE ORIFICE ASSEMBLY	3/8"-24 RH HP	40K psi (2758 bar)
17-002-014	0.014" STAT-TESTED SAPPHIRE ORIFICE ASSEMBLY (OS6 014)	3/8"-24 RH HP	40K psi (2758 bar)
17-002-015	0.015" STAT-TESTED SAPPHIRE ORIFICE ASSEMBLY (OS6 015)	3/8"-24 RH HP	40K psi (2758 bar)
17-002-016	0.016" STAT-TESTED SAPPHIRE ORIFICE ASSEMBLY	3/8"-24 RH HP	40K psi (2758 bar)
17-002-017	0.017" STAT-TESTED SAPPHIRE ORIFICE ASSEMBLY	3/8"-24 RH HP	40K psi (2758 bar)
17-002-018	0.018" STAT-TESTED SAPPHIRE ORIFICE ASSEMBLY	3/8"-24 RH HP	40K psi (2758 bar)
17-002-019	0.019" STAT-TESTED SAPPHIRE ORIFICE ASSEMBLY	3/8"-24 RH HP	40K psi (2758 bar)
17-002-020	0.020" STAT-TESTED SAPPHIRE ORIFICE ASSEMBLY	3/8"-24 RH HP	40K psi (2758 bar)
17-002-021	0.021" STAT-TESTED SAPPHIRE ORIFICE ASSEMBLY	3/8"-24 RH HP	40K psi (2758 bar)
17-002-022	0.022" STAT-TESTED SAPPHIRE ORIFICE ASSEMBLY	3/8"-24 RH HP	40K psi (2758 bar)
17-002-023	0.023" STAT-TESTED SAPPHIRE ORIFICE ASSEMBLY	3/8"-24 RH HP	40K psi (2758 bar)
17-002-024	0.024" STAT-TESTED SAPPHIRE ORIFICE ASSEMBLY (OS6 024)	3/8"-24 RH HP	40K psi (2758 bar)
17-002-025	0.025" STAT-TESTED SAPPHIRE ORIFICE ASSEMBLY	3/8"-24 RH HP	40K psi (2758 bar)
17-002-026	0.026" STAT-TESTED SAPPHIRE ORIFICE ASSEMBLY	3/8"-24 RH HP	40K psi (2758 bar)
17-002-027	0.027" STAT-TESTED SAPPHIRE ORIFICE ASSEMBLY	3/8"-24 RH HP	40K psi (2758 bar)
17-002-028	0.028" STAT-TESTED SAPPHIRE ORIFICE ASSEMBLY	3/8"-24 RH HP	40K psi (2758 bar)
17-002-029	0.029" STAT-TESTED SAPPHIRE ORIFICE ASSEMBLY	3/8"-24 RH HP	40K psi (2758 bar)
17-002-031	0.031" STAT-TESTED SAPPHIRE ORIFICE ASSEMBLY	3/8"-24 RH HP	40K psi (2758 bar)
17-002-033	0.033" STAT-TESTED SAPPHIRE ORIFICE ASSEMBLY	3/8"-24 RH HP	40K psi (2758 bar)
17-002-034	0.034" STAT-TESTED SAPPHIRE ORIFICE ASSEMBLY	3/8"-24 RH HP	40K psi (2758 bar)
17-002-035	0.035" STAT-TESTED SAPPHIRE ORIFICE ASSEMBLY	3/8"-24 RH HP	40K psi (2758 bar)
17-002-036	0.036" STAT-TESTED SAPPHIRE ORIFICE ASSEMBLY	3/8"-24 RH HP	40K psi (2758 bar)

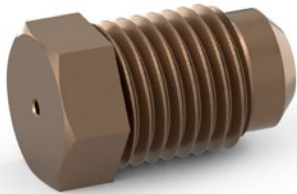
3/8"-24 RH HP STAT-TESTED SAPPHIRE ORIFICE ASSEMBLIES*(Continued)*

PART NO.	3/8"-24 RH HP STAT-TESTED SAPPHIRE ORIFICE ASSEMBLIES	INLET	MAX PRESSURE
17-002-039	0.039" STAT-TESTED SAPPHIRE ORIFICE ASSEMBLY	3/8"-24 RH HP	40K psi (2758 bar)
17-002-040	0.040" STAT-TESTED SAPPHIRE ORIFICE ASSEMBLY	3/8"-24 RH HP	40K psi (2758 bar)
17-002-042	0.042" STAT-TESTED SAPPHIRE ORIFICE ASSEMBLY (OS6 042)	3/8"-24 RH HP	40K psi (2758 bar)
17-002-043	0.043" STAT-TESTED SAPPHIRE ORIFICE ASSEMBLY	3/8"-24 RH HP	40K psi (2758 bar)
17-002-045	0.045" STAT-TESTED SAPPHIRE ORIFICE ASSEMBLY	3/8"-24 RH HP	40K psi (2758 bar)
17-002-047	0.047" STAT-TESTED SAPPHIRE ORIFICE ASSEMBLY (OS6 047)	3/8"-24 RH HP	40K psi (2758 bar)
17-002-050	0.050" STAT-TESTED SAPPHIRE ORIFICE ASSEMBLY	3/8"-24 RH HP	40K psi (2758 bar)

3/8"-24 RH HP PATENTED SAPPHIRE ORIFICE ASSEMBLIES

High-Performance Sapphire Nozzle Assemblies are compact inserts made to screw in to the most typical UHP rotary nozzles holder bodies common to UHP cleaning applications.

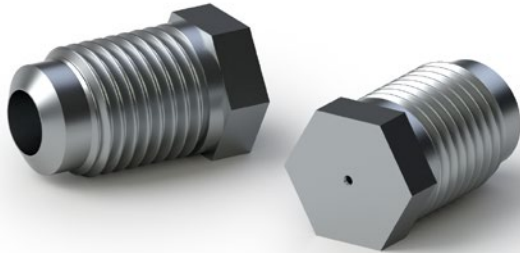

PART NO.	3/8"-24 RH HP PATENTED SAPPHIRE ORIFICE ASSEMBLIES	INLET	MAX PRESSURE
17-001-000	PATENTED SAPPHIRE ORIFICE PLUG (OS6-PLUG)	3/8"-24	40K psi (2758 bar)
17-001-007	0.007" PATENTED SAPPHIRE ORIFICE ASSEMBLY	3/8"-24 RH HP	40K psi (2758 bar)
17-001-008	0.008" PATENTED SAPPHIRE ORIFICE ASSEMBLY	3/8"-24 RH HP	40K psi (2758 bar)
17-001-009	0.009" PATENTED SAPPHIRE ORIFICE ASSEMBLY (GDWJ TYPE: 77408182-0,09)	3/8"-24 RH HP	40K psi (2758 bar)
17-001-010	0.010" PATENTED SAPPHIRE ORIFICE ASSEMBLY	3/8"-24 RH HP	40K psi (2758 bar)
17-001-011	0.011" PATENTED SAPPHIRE ORIFICE ASSEMBLY (GDWJ TYPE: 77408182-0,011)	3/8"-24 RH HP	40K psi (2758 bar)
17-001-012	0.012" PATENTED SAPPHIRE ORIFICE ASSEMBLY	3/8"-24 RH HP	40K psi (2758 bar)
17-001-013	0.013" PATENTED SAPPHIRE ORIFICE ASSEMBLY	3/8"-24 RH HP	40K psi (2758 bar)
17-001-014	0.014" PATENTED SAPPHIRE ORIFICE ASSEMBLY	3/8"-24 RH HP	40K psi (2758 bar)
17-001-015	0.015" PATENTED SAPPHIRE ORIFICE ASSEMBLY	3/8"-24 RH HP	40K psi (2758 bar)
17-001-016	0.016" PATENTED SAPPHIRE ORIFICE ASSEMBLY	3/8"-24 RH HP	40K psi (2758 bar)
17-001-017	0.017" PATENTED SAPPHIRE ORIFICE ASSEMBLY	3/8"-24 RH HP	40K psi (2758 bar)
17-001-018	0.018" PATENTED SAPPHIRE ORIFICE ASSEMBLY	3/8"-24 RH HP	40K psi (2758 bar)
17-001-019	0.019" PATENTED SAPPHIRE ORIFICE ASSEMBLY	3/8"-24 RH HP	40K psi (2758 bar)
17-001-020	0.020" PATENTED SAPPHIRE ORIFICE ASSEMBLY	3/8"-24 RH HP	40K psi (2758 bar)
17-001-021	0.021" PATENTED SAPPHIRE ORIFICE ASSEMBLY	3/8"-24 RH HP	40K psi (2758 bar)
17-001-022	0.022" PATENTED SAPPHIRE ORIFICE ASSEMBLY	3/8"-24 RH HP	40K psi (2758 bar)
17-001-023	0.023" PATENTED SAPPHIRE ORIFICE ASSEMBLY	3/8"-24 RH HP	40K psi (2758 bar)
17-001-024	0.024" PATENTED SAPPHIRE ORIFICE ASSEMBLY	3/8"-24 RH HP	40K psi (2758 bar)
17-001-025	0.025" PATENTED SAPPHIRE ORIFICE ASSEMBLY	3/8"-24 RH HP	40K psi (2758 bar)
17-001-026	0.026" PATENTED SAPPHIRE ORIFICE ASSEMBLY	3/8"-24 RH HP	40K psi (2758 bar)
17-001-027	0.027" PATENTED SAPPHIRE ORIFICE ASSEMBLY	3/8"-24 RH HP	40K psi (2758 bar)
17-001-028	0.028" PATENTED SAPPHIRE ORIFICE ASSEMBLY	3/8"-24 RH HP	40K psi (2758 bar)
17-001-029	0.029" PATENTED SAPPHIRE ORIFICE ASSEMBLY	3/8"-24 RH HP	40K psi (2758 bar)
17-001-030	0.030" PATENTED SAPPHIRE ORIFICE ASSEMBLY (GDWJ TYPE: 77408182-0,030)	3/8"-24 RH HP	40K psi (2758 bar)
17-001-031	0.031" PATENTED SAPPHIRE ORIFICE ASSEMBLY (GDWJ TYPE: 77408182-0,031)	3/8"-24 RH HP	40K psi (2758 bar)

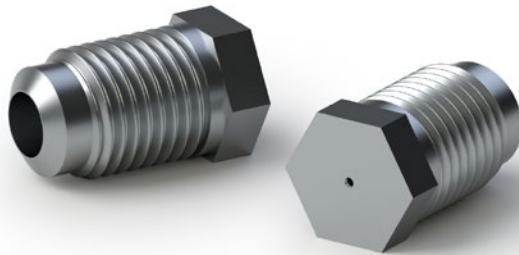
3/8"-24 RH HP PATENTED SAPPHIRE ORIFICE ASSEMBLIES*(Continued)*

PART NO.	3/8"-24 RH HP PATENTED SAPPHIRE ORIFICE ASSEMBLIES	INLET	MAX PRESSURE
17-001-032	0.032" PATENTED SAPPHIRE ORIFICE ASSEMBLY	3/8"-24 RH HP	40K psi (2758 bar)
17-001-034	0.033" PATENTED SAPPHIRE ORIFICE ASSEMBLY	3/8"-24 RH HP	40K psi (2758 bar)
17-001-035	0.034" PATENTED SAPPHIRE ORIFICE ASSEMBLY	3/8"-24 RH HP	40K psi (2758 bar)
17-001-036	0.036" PATENTED SAPPHIRE ORIFICE ASSEMBLY	3/8"-24 RH HP	40K psi (2758 bar)
17-001-037	0.037" PATENTED SAPPHIRE ORIFICE ASSEMBLY	3/8"-24 RH HP	40K psi (2758 bar)
17-001-038	0.038" PATENTED SAPPHIRE ORIFICE ASSEMBLY	3/8"-24 RH HP	40K psi (2758 bar)
17-001-039	0.039" PATENTED SAPPHIRE ORIFICE ASSEMBLY	3/8"-24 RH HP	40K psi (2758 bar)
17-001-040	0.040" PATENTED SAPPHIRE ORIFICE ASSEMBLY	3/8"-24 RH HP	40K psi (2758 bar)
17-001-041	0.041" PATENTED SAPPHIRE ORIFICE ASSEMBLY	3/8"-24 RH HP	40K psi (2758 bar)
17-001-042	0.042" PATENTED SAPPHIRE ORIFICE ASSEMBLY	3/8"-24 RH HP	40K psi (2758 bar)
17-001-043	0.043" PATENTED SAPPHIRE ORIFICE ASSEMBLY	3/8"-24 RH HP	40K psi (2758 bar)
17-001-044	0.044" PATENTED SAPPHIRE ORIFICE ASSEMBLY	3/8"-24 RH HP	40K psi (2758 bar)
17-001-045	0.045" PATENTED SAPPHIRE ORIFICE ASSEMBLY	3/8"-24 RH HP	40K psi (2758 bar)
17-001-046	0.046" PATENTED SAPPHIRE ORIFICE ASSEMBLY	3/8"-24 RH HP	40K psi (2758 bar)
17-001-048	0.048" PATENTED SAPPHIRE ORIFICE ASSEMBLY	3/8"-24 RH HP	40K psi (2758 bar)
17-001-049	0.049" PATENTED SAPPHIRE ORIFICE ASSEMBLY	3/8"-24 RH HP	40K psi (2758 bar)
17-001-050	0.050" PATENTED SAPPHIRE ORIFICE ASSEMBLY	3/8"-24 RH HP	40K psi (2758 bar)
17-001-051	0.051" PATENTED SAPPHIRE ORIFICE ASSEMBLY	3/8"-24 RH HP	40K psi (2758 bar)
17-001-052	0.052" PATENTED SAPPHIRE ORIFICE ASSEMBLY	3/8"-24 RH HP	40K psi (2758 bar)
17-001-055	0.055" PATENTED SAPPHIRE ORIFICE ASSEMBLY	3/8"-24 RH HP	40K psi (2758 bar)
17-001-056	0.056" PATENTED SAPPHIRE ORIFICE ASSEMBLY	3/8"-24 RH HP	40K psi (2758 bar)
17-001-058	0.058" PATENTED SAPPHIRE ORIFICE ASSEMBLY	3/8"-24 RH HP	40K psi (2758 bar)
17-001-059	0.059" PATENTED SAPPHIRE ORIFICE ASSEMBLY	3/8"-24 RH HP	40K psi (2758 bar)
17-001-060	0.060" PATENTED SAPPHIRE ORIFICE ASSEMBLY	3/8"-24 RH HP	40K psi (2758 bar)

7/16”-20 UNF HP STAT-TESTED SAPPHIRE ORIFICE ASSEMBLIES

These High Performance Sapphire Nozzle Assemblies are designed to be used with many typical UHP rotary nozzle holder bodies used in the most demanding cleaning applications.

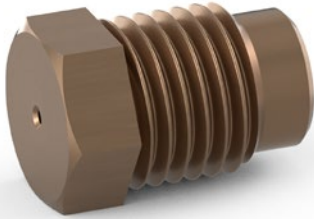

PART NO.	7/16”-20 UNF HP STAT-TESTED SAPPHIRE ORIFICE ASSEMBLIES	INLET	MAX PRESSURE
17-015-000	PATENTED PLUG	7/16”-20	40K psi (2758 bar)
17-015-008	0.008” SAPPHIRE WATERJET ORIFICE ASSEMBLY	7/16”-20 UNF HP	40K psi (2758 bar)
17-015-011	0.011” STAT-TESTED SAPPHIRE WATERJET ORIFICE ASSEMBLY	7/16”-20 UNF HP	40K psi (2758 bar)
17-015-012	0.012” SAPPHIRE WATERJET ORIFICE ASSEMBLY	7/16”-20 UNF HP	40K psi (2758 bar)
17-015-013	0.013” SAPPHIRE WATERJET ORIFICE ASSEMBLY	7/16”-20 UNF HP	40K psi (2758 bar)
17-015-014	0.014” STAT-TESTED SAPPHIRE WATERJET ORIFICE ASSEMBLY	7/16”-20 UNF HP	40K psi (2758 bar)
17-015-015	0.015” STAT-TESTED SAPPHIRE WATERJET ORIFICE ASSEMBLY (OS7 015)	7/16”-20 UNF HP	40K psi (2758 bar)
17-015-016	0.016” SAPPHIRE WATERJET ORIFICE ASSEMBLY (OS7 016)	7/16”-20 UNF HP	40K psi (2758 bar)
17-015-017	0.017” STAT-TESTED SAPPHIRE WATERJET ORIFICE ASSEMBLY (OS7 017)	7/16”-20 UNF HP	40K psi (2758 bar)
17-015-018	0.018” STAT-TESTED SAPPHIRE WATERJET ORIFICE ASSEMBLY	7/16”-20 UNF HP	40K psi (2758 bar)
17-015-019	0.019” STAT-TESTED SAPPHIRE WATERJET ORIFICE ASSEMBLY	7/16”-20 UNF HP	40K psi (2758 bar)
17-015-020	0.020” STAT-TESTED SAPPHIRE WATERJET ORIFICE ASSEMBLY	7/16”-20 UNF HP	40K psi (2758 bar)
17-015-021	0.021” STAT-TESTED SAPPHIRE WATERJET ORIFICE ASSEMBLY	7/16”-20 UNF HP	40K psi (2758 bar)
17-015-022	0.022” STAT-TESTED SAPPHIRE WATERJET ORIFICE ASSEMBLY	7/16”-20 UNF HP	40K psi (2758 bar)
17-015-023	0.023” STAT-TESTED SAPPHIRE WATERJET ORIFICE ASSEMBLY	7/16”-20 UNF HP	40K psi (2758 bar)
17-015-024	0.024” STAT-TESTED SAPPHIRE WATERJET ORIFICE ASSEMBLY	7/16”-20 UNF HP	40K psi (2758 bar)
17-015-025	0.025” STAT-TESTED SAPPHIRE WATERJET ORIFICE ASSEMBLY	7/16”-20 UNF HP	40K psi (2758 bar)
17-015-026	0.026” STAT-TESTED SAPPHIRE WATERJET ORIFICE ASSEMBLY	7/16”-20 UNF HP	40K psi (2758 bar)
17-015-027	0.027” STAT-TESTED SAPPHIRE WATERJET ORIFICE ASSEMBLY (OS7 027)	7/16”-20 UNF HP	40K psi (2758 bar)
17-015-028	0.028” STAT-TESTED SAPPHIRE WATERJET ORIFICE ASSEMBLY	7/16”-20 UNF HP	40K psi (2758 bar)
17-015-030	0.030” STAT-TESTED SAPPHIRE WATERJET ORIFICE ASSEMBLY	7/16”-20 UNF HP	40K psi (2758 bar)
17-015-031	0.031” STAT-TESTED SAPPHIRE WATERJET ORIFICE ASSEMBLY	7/16”-20 UNF HP	40K psi (2758 bar)
17-015-032	0.032” STAT-TESTED SAPPHIRE WATERJET ORIFICE ASSEMBLY	7/16”-20 UNF HP	40K psi (2758 bar)
17-015-033	0.033” STAT-TESTED SAPPHIRE WATERJET ORIFICE ASSEMBLY	7/16”-20 UNF HP	40K psi (2758 bar)
17-015-034	0.034” STAT-TESTED SAPPHIRE WATERJET ORIFICE ASSEMBLY	7/16”-20 UNF HP	40K psi (2758 bar)
17-015-035	0.035” STAT-TESTED SAPPHIRE WATERJET ORIFICE ASSEMBLY	7/16”-20 UNF HP	40K psi (2758 bar)
17-015-036	0.036” STAT-TESTED SAPPHIRE WATERJET ORIFICE ASSEMBLY	7/16”-20 UNF HP	40K psi (2758 bar)
17-015-037	0.037” STAT-TESTED SAPPHIRE WATERJET ORIFICE ASSEMBLY	7/16”-20 UNF HP	40K psi (2758 bar)
17-015-040	0.040” STAT-TESTED SAPPHIRE WATERJET ORIFICE ASSEMBLY	7/16”-20 UNF HP	40K psi (2758 bar)

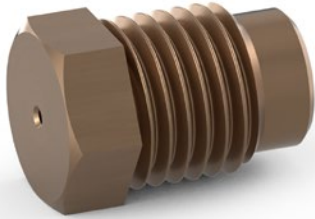
7/16"-20 UNF HP STAT-TESTED SAPPHIRE ORIFICE ASSEMBLIES*(Continued)*

PART NO.	7/16"-20 UNF HP STAT-TESTED SAPPHIRE ORIFICE ASSEMBLIES	INLET	MAX PRESSURE
17-015-041	0.041" SAPPHIRE WATERJET ORIFICE ASSEMBLY	7/16"-20 UNF HP	40K psi (2758 bar)
17-015-042	0.042" SAPPHIRE WATERJET ORIFICE ASSEMBLY	7/16"-20 UNF HP	40K psi (2758 bar)
17-015-043	0.043" SAPPHIRE WATERJET ORIFICE ASSEMBLY	7/16"-20 UNF HP	40K psi (2758 bar)
17-015-044	0.044" SAPPHIRE WATERJET ORIFICE ASSEMBLY	7/16"-20 UNF HP	40K psi (2758 bar)
17-015-045	0.045" SAPPHIRE WATERJET ORIFICE ASSEMBLY	7/16"-20 UNF HP	40K psi (2758 bar)
17-015-046	0.046" SAPPHIRE WATERJET ORIFICE ASSEMBLY	7/16"-20 UNF HP	40K psi (2758 bar)
17-015-047	0.047" SAPPHIRE WATERJET ORIFICE ASSEMBLY	7/16"-20 UNF HP	40K psi (2758 bar)
17-015-049	0.049" SAPPHIRE WATERJET ORIFICE ASSEMBLY	7/16"-20 UNF HP	40K psi (2758 bar)
17-015-050	0.050" SAPPHIRE WATERJET ORIFICE ASSEMBLY	7/16"-20 UNF HP	40K psi (2758 bar)
17-015-051	0.051" SAPPHIRE WATERJET ORIFICE ASSEMBLY	7/16"-20 UNF HP	40K psi (2758 bar)
17-015-052	0.052" STAT-TESTED SAPPHIRE WATERJET ORIFICE ASSEMBLY	7/16"-20 UNF HP	40K psi (2758 bar)
17-015-055	0.055" SAPPHIRE WATERJET ORIFICE ASSEMBLY	7/16"-20 UNF HP	40K psi (2758 bar)
17-015-057	0.057" SAPPHIRE WATERJET ORIFICE ASSEMBLY	7/16"-20 UNF HP	40K psi (2758 bar)
17-015-058	0.058" SAPPHIRE WATERJET ORIFICE ASSEMBLY	7/16"-20 UNF HP	40K psi (2758 bar)
17-015-059	0.059" SAPPHIRE WATERJET ORIFICE ASSEMBLY	7/16"-20 UNF HP	40K psi (2758 bar)
17-015-060	0.060" SAPPHIRE WATERJET ORIFICE ASSEMBLY	7/16"-20 UNF HP	40K psi (2758 bar)

BUTTON STYLE HP SAPPHIRE ORIFICE NOZZLE INSERTS

High Performance Sapphire Orifice Nozzle Inserts are compact inserts made to drop in to the typical nozzle jewel screw common to UHP cleaning applications.



PART NO.	BUTTON STYLE HP SAPPHIRE ORIFICE NOZZLE INSERTS	MAX PRESSURE
17-003-000	BUTTON STYLE 48° PLUG	40K psi (2758 bar)
17-003-001	3/8"-24 SOCKET HEAD JEWEL ORIFICE RETAINER SCREW (GDWJ TYPE: 77408199)	40K psi (2758 bar)
17-003-007	0.007" BUTTON STYLE 48° SAPPHIRE ORIFICE ASSEMBLY	40K psi (2758 bar)
17-003-008	0.008" BUTTON STYLE 48° SAPPHIRE ORIFICE ASSEMBLY	40K psi (2758 bar)
17-003-009	0.009" BUTTON STYLE 48° SAPPHIRE ORIFICE ASSEMBLY	40K psi (2758 bar)
17-003-010	0.010" BUTTON STYLE 48° SAPPHIRE ORIFICE ASSEMBLY (GDWJ TYPE: 77408191-010)	40K psi (2758 bar)
17-003-011	0.011" BUTTON STYLE 48° SAPPHIRE ORIFICE ASSEMBLY (GDWJ TYPE: 77408191-011)	40K psi (2758 bar)
17-003-012	0.012" BUTTON STYLE 48° SAPPHIRE ORIFICE ASSEMBLY	40K psi (2758 bar)
17-003-013	0.013" BUTTON STYLE 48° SAPPHIRE ORIFICE ASSEMBLY	40K psi (2758 bar)
17-003-014	0.014" BUTTON STYLE 48° SAPPHIRE ORIFICE ASSEMBLY	40K psi (2758 bar)
17-003-015	0.015" BUTTON STYLE 48° SAPPHIRE ORIFICE ASSEMBLY	40K psi (2758 bar)
17-003-016	0.016" BUTTON STYLE 48° SAPPHIRE ORIFICE ASSEMBLY	40K psi (2758 bar)
17-003-017	0.017" BUTTON STYLE 48° SAPPHIRE ORIFICE ASSEMBLY	40K psi (2758 bar)
17-003-018	0.018" BUTTON STYLE 48° SAPPHIRE ORIFICE ASSEMBLY	40K psi (2758 bar)
17-003-019	0.019" BUTTON STYLE 48° SAPPHIRE ORIFICE ASSEMBLY	40K psi (2758 bar)
17-003-020	0.020" BUTTON STYLE 48° SAPPHIRE ORIFICE ASSEMBLY	40K psi (2758 bar)
17-003-021	0.021" BUTTON STYLE 48° SAPPHIRE ORIFICE ASSEMBLY	40K psi (2758 bar)
17-003-022	0.022" BUTTON STYLE 48° SAPPHIRE ORIFICE ASSEMBLY	40K psi (2758 bar)
17-003-023	0.023" BUTTON STYLE 48° SAPPHIRE ORIFICE ASSEMBLY	40K psi (2758 bar)
17-003-024	0.024" BUTTON STYLE 48° SAPPHIRE ORIFICE ASSEMBLY	40K psi (2758 bar)
17-003-025	0.025" BUTTON STYLE 48° SAPPHIRE ORIFICE ASSEMBLY	40K psi (2758 bar)
17-003-026	0.026" BUTTON STYLE 48° SAPPHIRE ORIFICE ASSEMBLY	40K psi (2758 bar)
17-003-027	0.027" BUTTON STYLE 48° SAPPHIRE ORIFICE ASSEMBLY	40K psi (2758 bar)
17-003-028	0.028" BUTTON STYLE 48° SAPPHIRE ORIFICE ASSEMBLY	40K psi (2758 bar)
17-003-030	0.030" BUTTON STYLE 48° SAPPHIRE ORIFICE ASSEMBLY (GDWJ TYPE: 77408191-030)	40K psi (2758 bar)
17-003-031	0.031" BUTTON STYLE 48° SAPPHIRE ORIFICE ASSEMBLY (GDWJ TYPE: 77408191-031)	40K psi (2758 bar)
17-003-032	0.032" BUTTON STYLE 48° SAPPHIRE ORIFICE ASSEMBLY	40K psi (2758 bar)
17-003-033	0.033" BUTTON STYLE 48° SAPPHIRE ORIFICE ASSEMBLY	40K psi (2758 bar)
17-003-034	0.034" BUTTON STYLE 48° SAPPHIRE ORIFICE ASSEMBLY	40K psi (2758 bar)
17-003-035	0.035" BUTTON STYLE 48° SAPPHIRE ORIFICE ASSEMBLY (GDWJ TYPE: 77408191-035)	40K psi (2758 bar)

BUTTON STYLE HP SAPPHIRE ORIFICE NOZZLE INSERTS*(Continued)*

PART NO.	BUTTON STYLE HP SAPPHIRE ORIFICE NOZZLE INSERTS	MAX PRESSURE
17-003-036	0.036" BUTTON STYLE 48° SAPPHIRE ORIFICE ASSEMBLY	40K psi (2758 bar)
17-003-037	0.037" BUTTON STYLE 48° SAPPHIRE ORIFICE ASSEMBLY	40K psi (2758 bar)
17-003-038	0.038" BUTTON STYLE 48° SAPPHIRE ORIFICE ASSEMBLY	40K psi (2758 bar)
17-003-039	0.039" BUTTON STYLE 48° SAPPHIRE ORIFICE ASSEMBLY	40K psi (2758 bar)
17-003-040	0.040" BUTTON STYLE 48° SAPPHIRE ORIFICE ASSEMBLY	40K psi (2758 bar)
17-003-042	0.042" BUTTON STYLE 48° SAPPHIRE ORIFICE ASSEMBLY	40K psi (2758 bar)
17-003-044	0.044" BUTTON STYLE 48° SAPPHIRE ORIFICE ASSEMBLY	40K psi (2758 bar)
17-003-045	0.045" BUTTON STYLE 48° SAPPHIRE ORIFICE ASSEMBLY	40K psi (2758 bar)
17-003-046	0.046" BUTTON STYLE 48° SAPPHIRE ORIFICE ASSEMBLY	40K psi (2758 bar)
17-003-048	0.048" BUTTON STYLE 48° SAPPHIRE ORIFICE ASSEMBLY	40K psi (2758 bar)
17-003-050	0.050" BUTTON STYLE 48° SAPPHIRE ORIFICE ASSEMBLY	40K psi (2758 bar)
17-003-052	0.052" BUTTON STYLE 48° SAPPHIRE ORIFICE ASSEMBLY	40K psi (2758 bar)
17-003-055	0.055" BUTTON STYLE 48° SAPPHIRE ORIFICE ASSEMBLY	40K psi (2758 bar)
17-003-062	0.062" BUTTON STYLE 48° SAPPHIRE ORIFICE ASSEMBLY	40K psi (2758 bar)
17-009-000	BUTTON STYLE 60° PLUG	40K psi (2758 bar)
17-009-008	0.008" BUTTON STYLE 60° SAPPHIRE ORIFICE ASSEMBLY	40K psi (2758 bar)
17-009-009	0.009" BUTTON STYLE 60° SAPPHIRE ORIFICE ASSEMBLY	40K psi (2758 bar)
17-009-010	0.010" BUTTON STYLE 60° SAPPHIRE ORIFICE ASSEMBLY	40K psi (2758 bar)
17-009-011	0.011" BUTTON STYLE 60° SAPPHIRE ORIFICE ASSEMBLY	40K psi (2758 bar)
17-009-012	0.012" BUTTON STYLE 60° SAPPHIRE ORIFICE ASSEMBLY	40K psi (2758 bar)
17-009-013	0.013" BUTTON STYLE 60° SAPPHIRE ORIFICE ASSEMBLY	40K psi (2758 bar)
17-009-014	0.014" BUTTON STYLE 60° SAPPHIRE ORIFICE ASSEMBLY	40K psi (2758 bar)
17-009-016	0.016" BUTTON STYLE 60° SAPPHIRE ORIFICE ASSEMBLY	40K psi (2758 bar)
17-009-018	0.018" BUTTON STYLE 60° SAPPHIRE ORIFICE ASSEMBLY	40K psi (2758 bar)
17-009-019	0.019" BUTTON STYLE 60° SAPPHIRE ORIFICE ASSEMBLY	40K psi (2758 bar)
17-009-020	0.020" BUTTON STYLE 60° SAPPHIRE ORIFICE ASSEMBLY	40K psi (2758 bar)
17-009-022	0.022" BUTTON STYLE 60° SAPPHIRE ORIFICE ASSEMBLY	40K psi (2758 bar)
17-009-025	0.025" BUTTON STYLE 60° SAPPHIRE ORIFICE ASSEMBLY	40K psi (2758 bar)
17-009-028	0.028" BUTTON STYLE 60° SAPPHIRE ORIFICE ASSEMBLY	40K psi (2758 bar)

SLOTTED TYPE HP SAPPHIRE INSERT ASSEMBLIES

Our High Performance Sapphire Nozzle Inserts are compact inserts threaded M4 x 0.05” used in Ultra High Pressure (UHP) jetting applications. Also available in Hex Type (see next spread).



PART NO.	SLOTTED TYPE HP SAPPHIRE INSERT ASSEMBLIES	MAX PRESSURE
17-010-000	SLOTTED TYPE JEWEL NOZZLE PLUG ASSEMBLY	40K psi (2758 bar)
17-010-008	0.008" SAPPHIRE SLOTTED JEWEL NOZZLE ASSEMBLY	40K psi (2758 bar)
17-010-009	0.009" SAPPHIRE SLOTTED JEWEL NOZZLE ASSEMBLY	40K psi (2758 bar)
17-010-010	0.010" SAPPHIRE SLOTTED JEWEL NOZZLE ASSEMBLY	40K psi (2758 bar)
17-010-011	0.011" SAPPHIRE SLOTTED JEWEL NOZZLE ASSEMBLY	40K psi (2758 bar)
17-010-012	0.012" SAPPHIRE SLOTTED JEWEL NOZZLE ASSEMBLY	40K psi (2758 bar)
17-010-013	0.013" SAPPHIRE SLOTTED JEWEL NOZZLE ASSEMBLY	40K psi (2758 bar)
17-010-014	0.014" SAPPHIRE SLOTTED JEWEL NOZZLE ASSEMBLY	40K psi (2758 bar)
17-010-015	0.015" SAPPHIRE SLOTTED JEWEL NOZZLE ASSEMBLY	40K psi (2758 bar)
17-010-016	0.016" SAPPHIRE SLOTTED JEWEL NOZZLE ASSEMBLY	40K psi (2758 bar)
17-010-017	0.017" SAPPHIRE SLOTTED JEWEL NOZZLE ASSEMBLY	40K psi (2758 bar)
17-010-018	0.018" SAPPHIRE SLOTTED JEWEL NOZZLE ASSEMBLY	40K psi (2758 bar)
17-010-019	0.019" SAPPHIRE SLOTTED JEWEL NOZZLE ASSEMBLY	40K psi (2758 bar)
17-010-020	0.020" SAPPHIRE SLOTTED JEWEL NOZZLE ASSEMBLY	40K psi (2758 bar)
17-010-021	0.021" SAPPHIRE SLOTTED JEWEL NOZZLE ASSEMBLY	40K psi (2758 bar)
17-010-022	0.022" SAPPHIRE SLOTTED JEWEL NOZZLE ASSEMBLY	40K psi (2758 bar)
17-010-023	0.023" SAPPHIRE SLOTTED JEWEL NOZZLE ASSEMBLY	40K psi (2758 bar)
17-010-024	0.024" SAPPHIRE SLOTTED JEWEL NOZZLE ASSEMBLY	40K psi (2758 bar)
17-010-025	0.025" SAPPHIRE SLOTTED JEWEL NOZZLE ASSEMBLY	40K psi (2758 bar)
17-010-026	0.026" SAPPHIRE SLOTTED JEWEL NOZZLE ASSEMBLY	40K psi (2758 bar)
17-010-027	0.027" SAPPHIRE SLOTTED JEWEL NOZZLE ASSEMBLY	40K psi (2758 bar)
17-010-028	0.028" SAPPHIRE SLOTTED JEWEL NOZZLE ASSEMBLY	40K psi (2758 bar)
17-010-029	0.029" SAPPHIRE SLOTTED JEWEL NOZZLE ASSEMBLY	40K psi (2758 bar)
17-010-030	0.030" SAPPHIRE SLOTTED JEWEL NOZZLE ASSEMBLY	40K psi (2758 bar)
17-010-031	0.031" SAPPHIRE SLOTTED JEWEL NOZZLE ASSEMBLY	40K psi (2758 bar)
17-010-032	0.032" SAPPHIRE SLOTTED JEWEL NOZZLE ASSEMBLY	40K psi (2758 bar)
17-010-034	0.034" SAPPHIRE SLOTTED JEWEL NOZZLE ASSEMBLY	40K psi (2758 bar)
17-010-036	0.036" SAPPHIRE SLOTTED JEWEL NOZZLE ASSEMBLY	40K psi (2758 bar)
17-010-038	0.038" SAPPHIRE SLOTTED JEWEL NOZZLE ASSEMBLY	40K psi (2758 bar)

SLOTTED TYPE HP SAPPHIRE INSERT ASSEMBLIES*(Continued)*

PART NO.	SLOTTED TYPE HP SAPPHIRE INSERT ASSEMBLIES	MAX PRESSURE
17-010-039	0.039" SAPPHIRE SLOTTED JEWEL NOZZLE ASSEMBLY	40K psi (2758 bar)
17-010-040	0.040" SAPPHIRE SLOTTED JEWEL NOZZLE ASSEMBLY	40K psi (2758 bar)
17-010-041	0.041" SAPPHIRE SLOTTED JEWEL NOZZLE ASSEMBLY	40K psi (2758 bar)
17-010-042	0.042" SAPPHIRE SLOTTED JEWEL NOZZLE ASSEMBLY	40K psi (2758 bar)
17-010-043	0.043" SAPPHIRE SLOTTED JEWEL NOZZLE ASSEMBLY	40K psi (2758 bar)
17-010-044	0.044" SAPPHIRE SLOTTED JEWEL NOZZLE ASSEMBLY	40K psi (2758 bar)
17-010-045	0.045" SAPPHIRE SLOTTED JEWEL NOZZLE ASSEMBLY	40K psi (2758 bar)
17-010-046	0.046" SAPPHIRE SLOTTED JEWEL NOZZLE ASSEMBLY	40K psi (2758 bar)
17-010-048	0.048" SAPPHIRE SLOTTED JEWEL NOZZLE ASSEMBLY	40K psi (2758 bar)
17-010-049	0.049" SAPPHIRE SLOTTED JEWEL NOZZLE ASSEMBLY	40K psi (2758 bar)
17-010-050	0.050" SAPPHIRE SLOTTED JEWEL NOZZLE ASSEMBLY	40K psi (2758 bar)
17-010-051	0.051" SAPPHIRE SLOTTED JEWEL NOZZLE ASSEMBLY	40K psi (2758 bar)
17-010-052	0.052" SAPPHIRE SLOTTED JEWEL NOZZLE ASSEMBLY	40K psi (2758 bar)
17-010-100	M4 X 0.500" SLOTTED STAINLESS STEEL TYPE D JEWEL SCREW	40K psi (2758 bar)
17-010-101	M4 X 0.500" SLOTTED JEWEL SCREW PLUG	40K psi (2758 bar)

HEX TYPE HP SAPPHIRE INSERT ASSEMBLIES

Our High Performance Sapphire Nozzle Inserts are compact inserts threaded M4 x 0.05" used in Ultra High Pressure (UHP) jetting applications. Available in Slotted Type (see previous spread).



PART NO.	HEX TYPE SAPPHIRE INSERT ASSEMBLIES	MAX PRESSURE
17-006-000	M4 X 0.500" HEX STAINLESS STEEL JEWEL SCREW	40K psi (2758 bar)
17-006-001	TYPE D SAPPHIRE JEWEL SLEEVE (GDWJ TYPE: 77408144)	40K psi (2758 bar)
17-006-002	M4 X 0.500" STAINLESS STEEL HEX JEWEL SCREW PLUG	40K psi (2758 bar)
17-006-009	0.009" SAPPHIRE HEX JEWEL NOZZLE ASSEMBLY	40K psi (2758 bar)
17-006-012	0.012" SAPPHIRE HEX JEWEL NOZZLE ASSEMBLY	40K psi (2758 bar)
17-006-014	0.014" SAPPHIRE HEX JEWEL NOZZLE ASSEMBLY	40K psi (2758 bar)
17-006-015	0.015" SAPPHIRE HEX JEWEL NOZZLE ASSEMBLY	40K psi (2758 bar)
17-006-016	0.016" SAPPHIRE HEX JEWEL NOZZLE ASSEMBLY	40K psi (2758 bar)
17-006-017	0.017" SAPPHIRE HEX JEWEL NOZZLE ASSEMBLY	40K psi (2758 bar)
17-006-018	0.018" SAPPHIRE HEX JEWEL NOZZLE ASSEMBLY	40K psi (2758 bar)
17-006-019	0.019" SAPPHIRE HEX JEWEL NOZZLE ASSEMBLY	40K psi (2758 bar)
17-006-020	0.020" SAPPHIRE HEX JEWEL NOZZLE ASSEMBLY	40K psi (2758 bar)
17-006-021	0.021" SAPPHIRE HEX JEWEL NOZZLE ASSEMBLY	40K psi (2758 bar)
17-006-022	0.022" SAPPHIRE HEX JEWEL NOZZLE ASSEMBLY	40K psi (2758 bar)
17-006-023	0.023" SAPPHIRE HEX JEWEL NOZZLE ASSEMBLY	40K psi (2758 bar)
17-006-024	0.024" SAPPHIRE HEX JEWEL NOZZLE ASSEMBLY	40K psi (2758 bar)
17-006-025	0.025" SAPPHIRE HEX JEWEL NOZZLE ASSEMBLY	40K psi (2758 bar)
17-006-026	0.026" SAPPHIRE HEX JEWEL NOZZLE ASSEMBLY	40K psi (2758 bar)
17-006-027	0.027" SAPPHIRE HEX JEWEL NOZZLE ASSEMBLY	40K psi (2758 bar)
17-006-028	0.028" SAPPHIRE HEX JEWEL NOZZLE ASSEMBLY	40K psi (2758 bar)
17-006-031	0.031" SAPPHIRE HEX JEWEL NOZZLE ASSEMBLY	40K psi (2758 bar)
17-006-032	0.032" SAPPHIRE HEX JEWEL NOZZLE ASSEMBLY	40K psi (2758 bar)
17-006-034	0.034" SAPPHIRE HEX JEWEL NOZZLE ASSEMBLY	40K psi (2758 bar)
17-006-035	0.035" SAPPHIRE HEX JEWEL NOZZLE ASSEMBLY	40K psi (2758 bar)
17-006-036	0.036" SAPPHIRE HEX JEWEL NOZZLE ASSEMBLY	40K psi (2758 bar)
17-006-038	0.038" SAPPHIRE HEX JEWEL NOZZLE ASSEMBLY	40K psi (2758 bar)
17-006-039	0.039" SAPPHIRE HEX JEWEL NOZZLE ASSEMBLY	40K psi (2758 bar)
17-006-040	0.040" SAPPHIRE HEX JEWEL NOZZLE ASSEMBLY	40K psi (2758 bar)
17-006-043	0.043" SAPPHIRE HEX JEWEL NOZZLE ASSEMBLY	40K psi (2758 bar)
17-006-046	0.046" SAPPHIRE HEX JEWEL NOZZLE ASSEMBLY	40K psi (2758 bar)
17-006-052	0.052" SAPPHIRE HEX JEWEL NOZZLE ASSEMBLY	40K psi (2758 bar)
17-006-112	SAPPHIRE HEX JEWEL NOZZLE PLUG ASSEMBLY	40K psi (2758 bar)

SAPPHIRE INSERT SCREWDRIVERS

We offer specialized quality screwdrivers for use in installing the slotted sapphire nozzle inserts in to the sleeves. They feature a magnetic butt, pocket clip, and 1/8" blade.



PART NO.	SAPPHIRE INSERT SCREWDRIVERS
17-006-100	HEX TYPE JEWEL W/ MAGNET SCREWDRIVER ASSEMBLY
17-006-101	SLOTTED TYPE JEWEL W/ MAGNET SCREWDRIVER ASSEMBLY

PINEAPPLE LINE MOLE NOZZLES

Pineapple Line Mole Nozzles are made from stainless steel with a special copper coating to prevent galling during installation. These nozzles are used with line mole inserts, and wrench flats allow for easy installation.

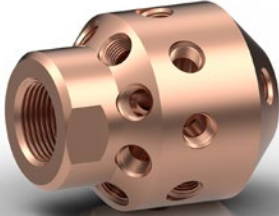

PART NO.	PINEAPPLE LINE MOLE NOZZLES	INLET	PORTS	MAX PRESSURE
15-018-201	APLM RADIAL PINEAPPLE NOZZLE	1" NPT	1/4" NPTF PORTS: 1 @ A, 3 @ B (45°), 8 @ C (90° RADIAL), 8 @ D (45°)	12K psi (827 bar)
15-018-200	APLM STANDARD PINEAPPLE NOZZLE	1" NPTF	1/4" NPTF PORTS: 1 @ A, 3 @ B (45°), 8 @ C (15° BACK), 8 @ D (45°)	15K psi (1034 bar)
15-018-202	BPLM STANDARD PINEAPPLE NOZZLE (GDWJ TYPE: 77118002-1)	1/2" NPTF	1/4" NPTF PORTS: 1 @ A, 3 @ B (45°), 6 @ C (15° BACK), 6 @ D (45°)	15K psi (1034 bar)
15-018-203	BPLM RADIAL PINEAPPLE NOZZLE	1/2" NPTF	1/4" NPTF PORTS: 1 @ A, 3 @ B (45°), 6 @ C (90° RADIAL), 6 @ D (45°)	15K psi (1034 bar)
15-018-204	BPLM STANDARD PINEAPPLE NOZZLE	3/4" NPTF	1/4" NPTF PORTS: 1 @ A, 3 @ B (45°), 6 @ C (15° BACK), 6 @ D (45°)	15K psi (1034 bar)
15-018-205	BPLM RADIAL PINEAPPLE NOZZLE	3/4" NPTF	1/4" NPTF PORTS: 1 @ A, 3 @ B (45°), 6 @ C (90° RADIAL), 6 @ D (45°)	15K psi (1034 bar)
15-018-206	CPLM STANDARD PINEAPPLE NOZZLE	1/2" NPTF	1/4" NPTF PORTS: 1 @ A, 3 @ D (45°)	15K psi (1034 bar)
15-018-207	DPLM STANDARD PINEAPPLE NOZZLE	3/4" NPTF	1/8" NPTF PORTS: 1 @ A, 3 @ B (45°), 6 @ C (15° BACK), 6 @ D (45°)	15K psi (1034 bar)
15-018-208	EPLM STANDARD PINEAPPLE NOZZLE	1/2" NPTF	1/16" NPTF PORTS: 1 @ A, 3 @ B (45°), 6 @ D (45°)	15K psi (1034 bar)
16-025-001	BPLM STANDARD PINEAPPLE NOZZLE	3/4" MPF	1/4"-28 FMS PORTS: 1 @ A, 3 @ B (45°) FORWARD, 6 @ C (0°) RADIAL, 6 @ D (45°) BACK	20K psi (1379 bar)
16-025-002	BPLM SPECIAL PINEAPPLE NOZZLE	3/4" MPF	1/2"-28 FMS PORTS: 3 @ B (45°) FORWARD, 4 @ C (0°) RADIAL, 4 @ D (45°) BACK	20K psi (1379 bar)
16-025-003	BPLM SPECIAL PINEAPPLE NOZZLE (1-5/8" DIAMETER)	3/4"-16 MP LH	2-1/4"-28 PORTS: 1 @ A, 1 @ B (60°), 1 @ C (90°), 1 @ D (45°)	20K psi (1379 bar)
16-025-004	BPLM SPECIAL PINEAPPLE NOZZLE (2-3/4" DIAMETER)	3/4" MP LH	PORTS: 1 @ A, 3-3/8"-24 JEWELLED PORTS @ B (45°), 6-3/8"-24 JEWELLED PORTS @ C (90°)	20K psi (1379 bar)
16-025-005	BPLM SPECIAL PINEAPPLE NOZZLE (1-5/8" DIAMETER)	3/4" MP LH	4-1/4"-28 PORTS: 1 @ B (60°), 1 @ C (90°), 1 @ D (45°)	20K psi (1379 bar)
16-025-006	BPLM SPECIAL PINEAPPLE NOZZLE (2-3/4" DIAMETER)	3/4"-16 MP LH	4-3/8"-24 JEWELLED PORTS: 1 @ B (60°), 1 @ C (90°), 1 @ D (45°)	20K psi (1379 bar)
16-025-007	BPLM SPECIAL PINEAPPLE NOZZLE (2-3/4" DIAMETER)	3/4" MP LH	4-3/8"-24 PORTS: 1 @ B (30°), 1 @ C (90°), 1 @ D (45°)	20K psi (1379 bar)

PINEAPPLE LINE MOLE NOZZLES

(Continued)

PART NO.	PINEAPPLE LINE MOLE NOZZLES	INLET	PORTS	MAX PRESSURE
16-025-009	BPLM SPECIAL PINEAPPLE NOZZLE (1-1/4" DIAMETER)	9/16" MP & 13/16"-16 RHF	4-1/16" NPTF PORTS: 1 @ C1 (15° FORWARD), 1 @ C2 (15° FORWARD MISALIGNED)	20K psi (1379 bar)
16-025-010	BPLM SPECIAL PINEAPPLE NOZZLE (2-1/4" DIAMETER X 4-1/2" LONG)	9/16" MP & 13/16"-16 RHF	PORTS: 2-1/4" NPTF PORTS @ C (90°), 4-1/4" NPTF PORTS @ D (45° ALIGNED)	20K psi (1379 bar)
16-025-020	BPLM SPECIAL PINEAPPLE NOZZLE (1-1/2" DIAMETER X 2.875" LONG)	9/16" MPF	2-1/4" PORTS: 2 @ C2 (20° BACK), 2 @ C1 (20° BACK)	20K psi (1379 bar)
16-025-107	BPLM SPECIAL PINEAPPLE NOZZLE (2-3/4" DIAMETER)	9/16" MP LH	4-3/8"-24 PORTS: 1 @ B (30°), 1 @ C (90°), 1 @ D (45°)	20K psi (1379 bar)
16-025-112	BPLM SPECIAL PINEAPPLE NOZZLE (2-3/4" DIAMETER)	9/16" MP LH	PORTS: 2-3/8"-24 RH JETS @ A2 (75° FORWARD), 4-3/8"-24 RH JETS @ B (45° FORWARD)	20K psi (1379 bar)
16-025-116	BPLM SPECIAL PINEAPPLE NOZZLE (1-9/16" DIAMETER)	9/16" MP LH	PORTS: 2-1/4"-28 RH JETS @ A2 (75° FORWARD), 4-1/4"-28 RH JETS @ B (45° FORWARD)	20K psi (1379 bar)
16-025-117	BPLM SPECIAL PINEAPPLE NOZZLE (1-15/16" DIAMETER)	9/16" MP LH	PORTS: 2-1/4"-28 RH JETS @ A2 (75° FORWARD), 4-1/4"-28 RH JETS @ B (45° FORWARD)	20K psi (1379 bar)
16-025-021	APLM SPECIAL TYPE M BUTTON NOSE PINEAPPLE NOZZLE (1-3/8" DIAMETER X 2.125" LONG)	7/8"-14	PORTS: 2-1/4"-28 JEWELLED PORT @ D (45° BACK W/ 90° SPACING), 1-1/4"-28 JEWELLED PORT @ C (90°), 1-1/4"-28 JEWELLED PORT @ A (75°)	40K psi (2758 bar)
16-025-105	APLM SPECIAL PINEAPPLE NOZZLE (1-5/8" DIAMETER)	9/16" HP LH	4-1/4"-28 PORTS: 1 @ B (60°), 1 @ C (90°), 1 @ D (45°)	40K psi (2758 bar)
16-025-106	APLM SPECIAL PINEAPPLE NOZZLE (2-3/4" DIAMETER)	9/16" HP LH	2-3/8"-24 PORTS: 1 @ C1, 1 @ C2	40K psi (2758 bar)
16-025-108	APLM SPECIAL PINEAPPLE NOZZLE (2-3/4" DIAMETER)	9/16" HP LH	3/8"-24 PORTS: 4 @ C (90° MIS-ALIGNED)	40K psi (2758 bar)
16-025-109	APLM SPECIAL PINEAPPLE NOZZLE (1-5/8" DIAMETER)	9/16" HP LH	2-1/4"-28 PORTS: 1 @ B (60° INCLUDED), 1 @ C (90°)	40K psi (2758 bar)
16-025-110	APLM SPECIAL PINEAPPLE NOZZLE (1-3/8" DIAMETER)	9/16" HP RH	4-1/4"-28 PORTS: 1 @ 2C1 (90°), 2 @ 2C2 (90°)	40K psi (2758 bar)
16-025-111	APLM SPECIAL PINEAPPLE NOZZLE (2-3/4" DIAMETER)	9/16" HP LH	PORTS: 2-3/8"-24 RH JETS @ A2 (75° FORWARD), 4-3/8"-24 RH JETS @ B (45° FORWARD)	40K psi (2758 bar)
16-025-113	APLM SPECIAL PINEAPPLE NOZZLE (1-9/16" DIAMETER)	9/16" HP LH	PORTS: 2-1/4"-28 RH JETS @ A2 (75° FORWARD), 4-1/4"-28 RH JETS @ B (45° FORWARD)	40K psi (2758 bar)
16-025-115	APLM SPECIAL PINEAPPLE NOZZLE (1-15/16" DIAMETER)	9/16" HP LH	PORTS: 2-1/4"-28 RH JETS @ A2 (75° FORWARD), 4-1/4"-28 RH JETS @ B (45° FORWARD)	40K psi (2758 bar)
16-025-118	APLM SPECIAL PINEAPPLE NOZZLE (2-3/4" DIAMETER)	9/16" HP LH	PORTS: 2-3/8"-24 RH JETS @ A2 (75° FORWARD), 4-3/8"-24 RH JETS @ B (45° FORWARD)	40K psi (2758 bar)
16-025-119	SPRAY BAR (6-1/4" DIAMETER) (TAPPED HOLE FOR HC 090 PULLING RING)	9/16" HP RH	PORTS: 2-1/4"-28 RH JETS @ 90°, 4-1/4"-28 RH JETS @ 30° INCLUDED	40K psi (2758 bar)
16-025-120	APLM SPECIAL PINEAPPLE NOZZLE (2-3/4" DIAMETER)	9/16" HP LH	PORTS: 2-3/8"-24 RH JETS @ C2 (90° MISALIGNED), 2-3/8"-24 RH JETS @ C1 (90°), 4-3/8"-24 RH JETS @ B (45° FORWARD)	40K psi (2758 bar)

STAINLESS STEEL LINE MOLE NOZZLE INSERTS

Stainless Steel Line Mole Nozzle Inserts are used primarily in Pineapple Line Mole Nozzles and are available with both drilled jets and Tungsten Carbide orifice inserts.

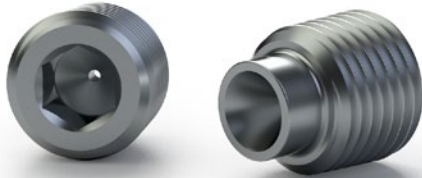

PART NO.	STAINLESS STEEL LINE MOLE NOZZLE INSERTS	INLET	MAX PRESSURE
15-218-000	STAINLESS STEEL LINE MOLE JET PLUG	1/16" NPT	15K psi (1034 bar)
15-218-016	0.016" STAINLESS STEEL LINE MOLE JET INSERT	1/16" NPT	15K psi (1034 bar)
15-218-021	0.021" STAINLESS STEEL LINE MOLE JET INSERT	1/16" NPT	15K psi (1034 bar)
15-218-024	0.024" STAINLESS STEEL LINE MOLE JET INSERT	1/16" NPT	15K psi (1034 bar)
15-218-026	0.026" STAINLESS STEEL LINE MOLE JET INSERT	1/16" NPT	15K psi (1034 bar)
15-218-028	0.028" STAINLESS STEEL LINE MOLE JET INSERT	1/16" NPT	15K psi (1034 bar)
15-218-031	0.031" STAINLESS STEEL LINE MOLE JET INSERT	1/16" NPT	15K psi (1034 bar)
15-218-036	0.036" STAINLESS STEEL LINE MOLE JET INSERT	1/16" NPT	15K psi (1034 bar)
15-218-043	0.043" STAINLESS STEEL LINE MOLE JET INSERT	1/16" NPT	15K psi (1034 bar)
15-218-047	0.047" STAINLESS STEEL LINE MOLE JET INSERT	1/16" NPT	15K psi (1034 bar)
15-218-050	0.050" STAINLESS STEEL LINE MOLE JET INSERT	1/16" NPT	15K psi (1034 bar)
15-218-052	0.052" STAINLESS STEEL LINE MOLE JET INSERT	1/16" NPT	15K psi (1034 bar)
15-218-055	0.055" STAINLESS STEEL LINE MOLE JET INSERT	1/16" NPT	15K psi (1034 bar)
15-218-059	0.059" STAINLESS STEEL LINE MOLE JET INSERT	1/16" NPT	15K psi (1034 bar)
15-218-062	0.062" STAINLESS STEEL LINE MOLE JET INSERT	1/16" NPT	15K psi (1034 bar)
15-218-067	0.067" STAINLESS STEEL LINE MOLE JET INSERT	1/16" NPT	15K psi (1034 bar)
15-218-070	0.070" STAINLESS STEEL LINE MOLE JET INSERT	1/16" NPT	15K psi (1034 bar)
15-218-076	0.076" STAINLESS STEEL LINE MOLE JET INSERT	1/16" NPT	15K psi (1034 bar)
15-218-082	0.082" STAINLESS STEEL LINE MOLE JET INSERT	1/16" NPT	15K psi (1034 bar)
15-218-085	0.085" STAINLESS STEEL LINE MOLE JET INSERT	1/16" NPT	15K psi (1034 bar)
15-218-093	0.093" STAINLESS STEEL LINE MOLE JET INSERT	1/16" NPT	15K psi (1034 bar)
15-218-100	0.100" STAINLESS STEEL LINE MOLE JET INSERT	1/16" NPT	15K psi (1034 bar)
15-218-118	0.118" STAINLESS STEEL LINE MOLE JET INSERT	1/16" NPT	15K psi (1034 bar)
15-218-125	0.125" STAINLESS STEEL LINE MOLE JET INSERT	1/16" NPT	15K psi (1034 bar)
15-118-000	STAINLESS STEEL LINE MOLE JET SOCKET HEAD PIPE PLUG	1/8" NPT	15K psi (1034 bar)
15-118-016	0.016" STAINLESS STEEL LINE MOLE JET INSERT	1/8" NPT	15K psi (1034 bar)
15-118-021	0.021" STAINLESS STEEL LINE MOLE JET INSERT	1/8" NPT	15K psi (1034 bar)
15-118-024	0.024" STAINLESS STEEL LINE MOLE JET INSERT	1/8" NPT	15K psi (1034 bar)
15-118-026	0.026" STAINLESS STEEL LINE MOLE JET INSERT	1/8" NPT	15K psi (1034 bar)
15-118-028	0.028" STAINLESS STEEL LINE MOLE JET INSERT	1/8" NPT	15K psi (1034 bar)
15-118-031	0.031" STAINLESS STEEL LINE MOLE JET INSERT	1/8" NPT	15K psi (1034 bar)
15-118-036	0.036" STAINLESS STEEL LINE MOLE JET INSERT	1/8" NPT	15K psi (1034 bar)
15-118-043	0.043" STAINLESS STEEL LINE MOLE JET INSERT	1/8" NPT	15K psi (1034 bar)

STAINLESS STEEL LINE MOLE NOZZLE INSERTS*(Continued)*

PART NO.	STAINLESS STEEL LINE MOLE NOZZLE INSERTS	INLET	MAX PRESSURE
15-118-047	0.047" STAINLESS STEEL LINE MOLE JET INSERT	1/8" NPT	15K psi (1034 bar)
15-118-050	0.050" STAINLESS STEEL LINE MOLE JET INSERT	1/8" NPT	15K psi (1034 bar)
15-118-052	0.052" STAINLESS STEEL LINE MOLE JET INSERT	1/8" NPT	15K psi (1034 bar)
15-118-055	0.055" STAINLESS STEEL LINE MOLE JET INSERT	1/8" NPT	15K psi (1034 bar)
15-118-059	0.059" STAINLESS STEEL LINE MOLE JET INSERT	1/8" NPT	15K psi (1034 bar)
15-118-062	0.062" STAINLESS STEEL LINE MOLE JET INSERT	1/8" NPT	15K psi (1034 bar)
15-118-067	0.067" STAINLESS STEEL LINE MOLE JET INSERT	1/8" NPT	15K psi (1034 bar)
15-118-070	0.070" STAINLESS STEEL LINE MOLE JET INSERT	1/8" NPT	15K psi (1034 bar)
15-118-076	0.076" STAINLESS STEEL LINE MOLE JET INSERT	1/8" NPT	15K psi (1034 bar)
15-118-082	0.082" STAINLESS STEEL LINE MOLE JET INSERT	1/8" NPT	15K psi (1034 bar)
15-118-085	0.085" STAINLESS STEEL LINE MOLE JET INSERT	1/8" NPT	15K psi (1034 bar)
15-118-093	0.093" STAINLESS STEEL LINE MOLE JET INSERT	1/8" NPT	15K psi (1034 bar)
15-118-100	0.100" STAINLESS STEEL LINE MOLE JET INSERT	1/8" NPT	15K psi (1034 bar)
15-118-118	0.118" STAINLESS STEEL LINE MOLE JET INSERT	1/8" NPT	15K psi (1034 bar)
15-118-125	0.125" STAINLESS STEEL LINE MOLE JET INSERT	1/8" NPT	15K psi (1034 bar)
15-018-000	STAINLESS STEEL LINE MOLE JET SOCKET HEAD PIPE PLUG	1/4" NPT	15K psi (1034 bar)
15-018-016	0.016" STAINLESS STEEL LINE MOLE JET INSERT	1/4" NPT	15K psi (1034 bar)
15-018-018	0.018" STAINLESS STEEL LINE MOLE JET INSERT	1/4" NPT	15K psi (1034 bar)
15-018-020	0.020" STAINLESS STEEL LINE MOLE JET INSERT	1/4" NPT	15K psi (1034 bar)
15-018-021	0.021" STAINLESS STEEL LINE MOLE JET INSERT	1/4" NPT	15K psi (1034 bar)
15-018-022	0.022" STAINLESS STEEL LINE MOLE JET INSERT	1/4" NPT	15K psi (1034 bar)
15-018-024	0.024" STAINLESS STEEL LINE MOLE JET INSERT	1/4" NPT	15K psi (1034 bar)
15-018-026	0.026" STAINLESS STEEL LINE MOLE JET INSERT	1/4" NPT	15K psi (1034 bar)
15-018-028	0.028" STAINLESS STEEL LINE MOLE JET INSERT	1/4" NPT	15K psi (1034 bar)
15-018-029	0.029" STAINLESS STEEL LINE MOLE JET INSERT	1/4" NPT	15K psi (1034 bar)
15-018-031	0.031" STAINLESS STEEL LINE MOLE JET INSERT	1/4" NPT	15K psi (1034 bar)
15-018-036	0.036" STAINLESS STEEL LINE MOLE JET INSERT	1/4" NPT	15K psi (1034 bar)
15-018-043	0.043" STAINLESS STEEL LINE MOLE JET INSERT	1/4" NPT	15K psi (1034 bar)
15-018-047	0.047" STAINLESS STEEL LINE MOLE JET INSERT	1/4" NPT	15K psi (1034 bar)
15-018-050	0.050" STAINLESS STEEL LINE MOLE JET INSERT	1/4" NPT	15K psi (1034 bar)
15-018-052	0.052" STAINLESS STEEL LINE MOLE JET INSERT	1/4" NPT	15K psi (1034 bar)
15-018-055	0.055" STAINLESS STEEL LINE MOLE JET INSERT	1/4" NPT	15K psi (1034 bar)
15-018-059	0.059" STAINLESS STEEL LINE MOLE JET INSERT	1/4" NPT	15K psi (1034 bar)
15-018-062	0.062" STAINLESS STEEL LINE MOLE JET INSERT	1/4" NPT	15K psi (1034 bar)
15-018-067	0.067" STAINLESS STEEL LINE MOLE JET INSERT	1/4" NPT	15K psi (1034 bar)
15-018-070	0.070" STAINLESS STEEL LINE MOLE JET INSERT	1/4" NPT	15K psi (1034 bar)
15-018-076	0.076" STAINLESS STEEL LINE MOLE JET INSERT	1/4" NPT	15K psi (1034 bar)
15-018-082	0.082" STAINLESS STEEL LINE MOLE JET INSERT	1/4" NPT	15K psi (1034 bar)
15-018-085	0.085" STAINLESS STEEL LINE MOLE JET INSERT	1/4" NPT	15K psi (1034 bar)
15-018-093	0.093" STAINLESS STEEL LINE MOLE JET INSERT	1/4" NPT	15K psi (1034 bar)
15-018-100	0.100" STAINLESS STEEL LINE MOLE JET INSERT	1/4" NPT	15K psi (1034 bar)
15-018-118	0.118" STAINLESS STEEL LINE MOLE JET INSERT	1/4" NPT	15K psi (1034 bar)
15-018-125	0.125" STAINLESS STEEL LINE MOLE JET INSERT	1/4" NPT	15K psi (1034 bar)

TUNGSTEN CARBIDE LINE MOLE NOZZLE INSERTS

These Tungsten Carbide Line Mole Nozzle Inserts are used primarily in Pineapple Line Mole Nozzles. They are available with both drilled jets and also with Stainless Steel orifice inserts.



PART NO.	TUNGSTEN CARBIDE LINE MOLE NOZZLE INSERTS	INLET	MAX PRESSURE
15-018-000	STAINLESS STEEL LINE MOLE JET SOCKET HEAD PIPE PLUG (GDWJ TYPE: 77118006)	1/4" NPT	15K psi (1034 bar)
15-019-021	0.021" FLUSH MOUNT TUNGSTEN CARBIDE NOZZLE (GDWJ TYPE: 77118048)	1/4" NPT	15K psi (1034 bar)
15-019-024	0.024" FLUSH MOUNT TUNGSTEN CARBIDE NOZZLE	1/4" NPT	15K psi (1034 bar)
15-019-026	0.026" FLUSH MOUNT TUNGSTEN CARBIDE NOZZLE (#1)	1/4" NPT	15K psi (1034 bar)
15-019-031	0.031" FLUSH MOUNT TUNGSTEN CARBIDE NOZZLE (#1.5)	1/4" NPT	15K psi (1034 bar)
15-019-036	0.036" FLUSH MOUNT TUNGSTEN CARBIDE NOZZLE (#2)	1/4" NPT	15K psi (1034 bar)
15-019-039	0.039" FLUSH MOUNT TUNGSTEN CARBIDE NOZZLE (#2.5)	1/4" NPT	15K psi (1034 bar)
15-019-043	0.043" FLUSH MOUNT TUNGSTEN CARBIDE NOZZLE (#3) (GDWJ TYPE: 77118058)	1/4" NPT	15K psi (1034 bar)
15-019-047	0.047" FLUSH MOUNT TUNGSTEN CARBIDE NOZZLE (#4)	1/4" NPT	15K psi (1034 bar)
15-019-050	0.050" FLUSH MOUNT TUNGSTEN CARBIDE NOZZLE (#4.5)	1/4" NPT	15K psi (1034 bar)
15-019-052	0.052" FLUSH MOUNT TUNGSTEN CARBIDE NOZZLE (#5)	1/4" NPT	15K psi (1034 bar)
15-019-055	0.055" FLUSH MOUNT TUNGSTEN CARBIDE NOZZLE (#5.5)	1/4" NPT	15K psi (1034 bar)
15-019-059	0.059" FLUSH MOUNT TUNGSTEN CARBIDE NOZZLE (#6)	1/4" NPT	15K psi (1034 bar)
15-019-062	0.062" FLUSH MOUNT TUNGSTEN CARBIDE NOZZLE (#7)	1/4" NPT	15K psi (1034 bar)
15-019-065	0.065" FLUSH MOUNT TUNGSTEN CARBIDE NOZZLE (#7.5)	1/4" NPT	15K psi (1034 bar)
15-019-067	0.067" FLUSH MOUNT TUNGSTEN CARBIDE NOZZLE (#8)	1/4" NPT	15K psi (1034 bar)
15-019-071	0.071" FLUSH MOUNT TUNGSTEN CARBIDE NOZZLE (#9)	1/4" NPT	15K psi (1034 bar)
15-019-073	0.073" FLUSH MOUNT TUNGSTEN CARBIDE NOZZLE (#9.5)	1/4" NPT	15K psi (1034 bar)
15-019-075	0.075" FLUSH MOUNT TUNGSTEN CARBIDE NOZZLE (#10)	1/4" NPT	15K psi (1034 bar)
15-019-078	0.078" FLUSH MOUNT TUNGSTEN CARBIDE NOZZLE (#11)	1/4" NPT	15K psi (1034 bar)
15-019-082	0.082" FLUSH MOUNT TUNGSTEN CARBIDE NOZZLE (#12)	1/4" NPT	15K psi (1034 bar)
15-019-085	0.085" FLUSH MOUNT TUNGSTEN CARBIDE NOZZLE (#12.5)	1/4" NPT	15K psi (1034 bar)
15-019-089	0.089" FLUSH MOUNT TUNGSTEN CARBIDE NOZZLE (#14)	1/4" NPT	15K psi (1034 bar)
15-019-093	0.093" FLUSH MOUNT TUNGSTEN CARBIDE NOZZLE (#15)	1/4" NPT	15K psi (1034 bar)
15-019-100	0.100" FLUSH MOUNT TUNGSTEN CARBIDE NOZZLE (#18)	1/4" NPT	15K psi (1034 bar)
15-019-106	0.106" FLUSH MOUNT TUNGSTEN CARBIDE NOZZLE (#20) (OCIH 106)	1/4" NPT	15K psi (1034 bar)
15-019-109	0.109" FLUSH MOUNT TUNGSTEN CARBIDE NOZZLE (#21)	1/4" NPT	15K psi (1034 bar)
15-019-118	0.118" FLUSH MOUNT TUNGSTEN CARBIDE NOZZLE (#25)	1/4" NPT	15K psi (1034 bar)
15-019-125	0.125" FLUSH MOUNT TUNGSTEN CARBIDE NOZZLE (#27)	1/4" NPT	15K psi (1034 bar)
15-019-130	0.130" FLUSH MOUNT TUNGSTEN CARBIDE NOZZLE (#30)	1/4" NPT	15K psi (1034 bar)
15-019-140	0.140" FLUSH MOUNT TUNGSTEN CARBIDE NOZZLE (#35) (OCIH 140)	1/4" NPT	15K psi (1034 bar)
15-019-156	0.156" FLUSH MOUNT TUNGSTEN CARBIDE NOZZLE (#40) (OCIH 156)	1/4" NPT	15K psi (1034 bar)
15-019-165	0.165" FLUSH MOUNT TUNGSTEN CARBIDE NOZZLE (#50) (OCIH 165)	1/4" NPT	15K psi (1034 bar)

TUNGSTEN CARBIDE HARD HITTER NOZZLES

Tungsten Carbide Hard Hitter Nozzles are designed especially for use with hand-held control guns for superior surface cleaning and are made of stainless steel with tungsten carbide orifice inserts. Replaceable carbide inserts are also available.

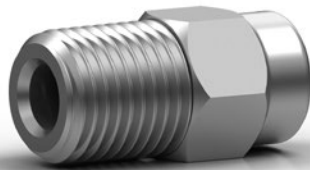

PART NO.	TUNGSTEN CARBIDE HARD HITTER NOZZLES	INLET	MAX PRESSURE
15-021-021	0.021" TUNGSTEN CARBIDE HARD HITTER NOZZLE	1/4" NPT	15K psi (1034 bar)
15-021-024	0.024" TUNGSTEN CARBIDE HARD HITTER NOZZLE	1/4" NPT	15K psi (1034 bar)
15-021-026	0.026" TUNGSTEN CARBIDE HARD HITTER NOZZLE (#1)	1/4" NPT	15K psi (1034 bar)
15-021-031	0.031" TUNGSTEN CARBIDE HARD HITTER NOZZLE (#1.5)	1/4" NPT	15K psi (1034 bar)
15-021-036	0.036" TUNGSTEN CARBIDE HARD HITTER NOZZLE (#2) (GDWJ TYPE: 77115006)	1/4" NPT	15K psi (1034 bar)
15-021-039	0.039" TUNGSTEN CARBIDE HARD HITTER NOZZLE (#2.5)	1/4" NPT	15K psi (1034 bar)
15-021-043	0.043" TUNGSTEN CARBIDE HARD HITTER NOZZLE (#3) (OCV-.043)	1/4" NPT	15K psi (1034 bar)
15-021-047	0.047" TUNGSTEN CARBIDE HARD HITTER NOZZLE (#4) (GDWJ TYPE: 77115008) (OCV-0.047)	1/4" NPT	15K psi (1034 bar)
15-021-050	0.050" TUNGSTEN CARBIDE HARD HITTER NOZZLE (#4.5)	1/4" NPT	15K psi (1034 bar)
15-021-052	0.052" TUNGSTEN CARBIDE HARD HITTER NOZZLE (#5)	1/4" NPT	15K psi (1034 bar)
15-021-055	0.055" TUNGSTEN CARBIDE HARD HITTER NOZZLE (#5.5) (OCV-0.055)	1/4" NPT	15K psi (1034 bar)
15-021-059	0.059" TUNGSTEN CARBIDE HARD HITTER NOZZLE (#6) (GDWJ TYPE: 77115012)	1/4" NPT	15K psi (1034 bar)
15-021-060	0.060" TUNGSTEN CARBIDE HARD HITTER NOZZLE (#6.5)	1/4" NPT	15K psi (1034 bar)
15-021-062	0.062" TUNGSTEN CARBIDE HARD HITTER NOZZLE (#7)	1/4" NPT	15K psi (1034 bar)
15-021-065	0.065" TUNGSTEN CARBIDE HARD HITTER NOZZLE (#7.5)	1/4" NPT	15K psi (1034 bar)
15-021-067	0.067" TUNGSTEN CARBIDE HARD HITTER NOZZLE (#8) (GDWJ TYPE: 77115016)	1/4" NPT	15K psi (1034 bar)
15-021-071	0.071" TUNGSTEN CARBIDE HARD HITTER NOZZLE (#9)	1/4" NPT	15K psi (1034 bar)
15-021-073	0.073" TUNGSTEN CARBIDE HARD HITTER NOZZLE (#9.5)	1/4" NPT	15K psi (1034 bar)
15-021-075	0.075" TUNGSTEN CARBIDE HARD HITTER NOZZLE (#10) (OCV-0.075)	1/4" NPT	15K psi (1034 bar)
15-021-078	0.078" TUNGSTEN CARBIDE HARD HITTER NOZZLE (#11) (GDWJ TYPE: 77115022)	1/4" NPT	15K psi (1034 bar)
15-021-082	0.082" TUNGSTEN CARBIDE HARD HITTER NOZZLE (#12)	1/4" NPT	15K psi (1034 bar)
15-021-085	0.085" TUNGSTEN CARBIDE HARD HITTER NOZZLE (#13) (GDWJ TYPE: 77115026) (OCV-085)	1/4" NPT	15K psi (1034 bar)
15-021-089	0.089" TUNGSTEN CARBIDE HARD HITTER NOZZLE (#14)	1/4" NPT	15K psi (1034 bar)
15-021-093	0.093" TUNGSTEN CARBIDE HARD HITTER NOZZLE (#15) (GDWJ TYPE: 77115028)	1/4" NPT	15K psi (1034 bar)
15-021-100	0.100" TUNGSTEN CARBIDE HARD HITTER NOZZLE (#18) (GDWJ TYPE: 77115030)	1/4" NPT	15K psi (1034 bar)
15-021-106	0.106" TUNGSTEN CARBIDE HARD HITTER NOZZLE (#20) (OCV-0.106)	1/4" NPT	15K psi (1034 bar)
15-021-109	0.109" TUNGSTEN CARBIDE HARD HITTER NOZZLE (#21)	1/4" NPT	15K psi (1034 bar)
15-021-118	0.118" TUNGSTEN CARBIDE HARD HITTER NOZZLE (#25)	1/4" NPT	15K psi (1034 bar)
15-021-125	0.125" TUNGSTEN CARBIDE HARD HITTER NOZZLE (#27) (OCV-0.125)	1/4" NPT	15K psi (1034 bar)
15-021-130	0.130" TUNGSTEN CARBIDE HARD HITTER NOZZLE (#30)	1/4" NPT	15K psi (1034 bar)
15-021-140	0.140" TUNGSTEN CARBIDE HARD HITTER NOZZLE (#35)	1/4" NPT	15K psi (1034 bar)
15-021-156	0.156" TUNGSTEN CARBIDE HARD HITTER NOZZLE (#40)	1/4" NPT	15K psi (1034 bar)

GUN BARREL HARD HITTER MNPT NOZZLES

Our Gun Barrel Hard Hitter Nozzles bring exceptional power to control guns. Each is made from heat treated stainless steel and features male NPT threads and wrench flats for easy installation.

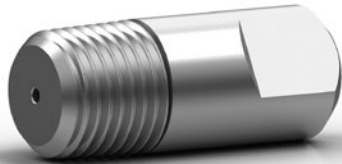

PART NO.	GUN BARREL HARD HITTER MNPT NOZZLES	MAX PRESSURE
15-010-028	0.028" GUN BARREL STYLE HARD HITTER NOZZLE (GBS-1)	15K psi (1034 bar)
15-010-036	0.036" GUN BARREL STYLE HARD HITTER NOZZLE (GBS-2)	15K psi (1034 bar)
15-010-043	0.043" GUN BARREL STYLE HARD HITTER NOZZLE (GBS-3)	15K psi (1034 bar)
15-010-047	0.047" GUN BARREL STYLE HARD HITTER NOZZLE (GBS-4) (K9)	15K psi (1034 bar)
15-010-052	0.052" GUN BARREL STYLE HARD HITTER NOZZLE (GBS-5)	15K psi (1034 bar)
15-010-055	0.055" GUN BARREL STYLE HARD HITTER NOZZLE (GBS-5.5)	15K psi (1034 bar)
15-010-059	0.059" GUN BARREL STYLE HARD HITTER NOZZLE (GBS-6) (K3)	15K psi (1034 bar)
15-010-062	0.062" GUN BARREL STYLE HARD HITTER NOZZLE (GBS-7) (K7)	15K psi (1034 bar)
15-010-067	0.067" GUN BARREL STYLE HARD HITTER NOZZLE (GBS-8)	15K psi (1034 bar)
15-010-071	0.071" GUN BARREL STYLE HARD HITTER NOZZLE (GBS-9)	15K psi (1034 bar)
15-010-075	0.075" GUN BARREL STYLE HARD HITTER NOZZLE (GBS-10) (GDWJ TYPE: 77111020)	15K psi (1034 bar)
15-010-078	0.078" GUN BARREL STYLE HARD HITTER NOZZLE (GBS-11)	15K psi (1034 bar)
15-010-082	0.082" GUN BARREL STYLE HARD HITTER NOZZLE (GBS-12)	15K psi (1034 bar)
15-010-085	0.085" GUN BARREL STYLE HARD HITTER NOZZLE (GBS-13) (K2)	15K psi (1034 bar)
15-010-089	0.089" GUN BARREL STYLE HARD HITTER NOZZLE (GBS-14)	15K psi (1034 bar)
15-010-187	0.187" GUN BARREL STYLE HARD HITTER NOZZLE (GBS-60) (K6)	15K psi (1034 bar)
15-010-093	0.093" GUN BARREL STYLE HARD HITTER NOZZLE (GBS-15) (GDWJ TYPE: 77111028)	15K psi (1034 bar)
15-010-094	0.094" GUN BARREL STYLE HARD HITTER NOZZLE (GBS-15) (K4)	15K psi (1034 bar)
15-010-095	0.095" GUN BARREL STYLE HARD HITTER NOZZLE (GBS)	15K psi (1034 bar)
15-010-100	0.100" GUN BARREL STYLE HARD HITTER NOZZLE (GBS-18)	15K psi (1034 bar)
15-010-106	0.106" GUN BARREL STYLE HARD HITTER NOZZLE (GBS-20)	15K psi (1034 bar)
15-010-111	0.111" GUN BARREL STYLE HARD HITTER NOZZLE (GBS-21) (K1)	15K psi (1034 bar)
15-010-118	0.118" GUN BARREL STYLE HARD HITTER NOZZLE (GBS-25)	15K psi (1034 bar)
15-010-125	0.125" GUN BARREL STYLE HARD HITTER NOZZLE (GBS-27) (K5)	15K psi (1034 bar)
15-010-130	0.130" GUN BARREL STYLE HARD HITTER NOZZLE (GBS-30)	15K psi (1034 bar)
15-010-140	0.140" GUN BARREL STYLE HARD HITTER NOZZLE (GBS-35) (K20)	15K psi (1034 bar)
15-010-156	0.156" GUN BARREL STYLE HARD HITTER NOZZLE (GBS-40)	15K psi (1034 bar)
15-010-187	0.187" GUN BARREL STYLE HARD HITTER NOZZLE (GBS-60) (K6)	15K psi (1034 bar)

1/4" MEG MNPT HARD HITTER NOZZLES

1/4" Meg Hard Hitter Nozzles bring exceptional power to control gun surface cleaning and cutting applications. The internal guide vane focuses flow for maximum performance. They are made from hardened stainless steel and feature male NPT threads and wrench flats for easy installation.



PART NO.	1/4" MEG MNPT HARD HITTER NOZZLES	INLET	MAX PRESSURE
15-013-001	0.036" JET SIZE NOZZLE (0002)	1/4"-MEG MNPT	15K psi (1034 bar)
15-013-002	0.043" JET SIZE NOZZLE (0003)	1/4"-MEG MNPT	15K psi (1034 bar)
15-013-003	0.047" JET SIZE NOZZLE (0004)	1/4"-MEG MNPT	15K psi (1034 bar)
15-013-004	0.050" JET SIZE NOZZLE (0004.5)	1/4"-MEG MNPT	15K psi (1034 bar)
15-013-005	0.052" JET SIZE NOZZLE (0005)	1/4"-MEG MNPT	15K psi (1034 bar)
15-013-006	0.055" JET SIZE NOZZLE (0005.5)	1/4"-MEG MNPT	15K psi (1034 bar)
15-013-007	0.059" JET SIZE NOZZLE (0006)	1/4"-MEG MNPT	15K psi (1034 bar)
15-013-008	0.060" JET SIZE NOZZLE (0006.5)	1/4"-MEG MNPT	15K psi (1034 bar)
15-013-009	0.062" JET SIZE NOZZLE (0007)	1/4"-MEG MNPT	15K psi (1034 bar)
15-013-010	0.067" JET SIZE NOZZLE (0008)	1/4"-MEG MNPT	15K psi (1034 bar)
15-013-011	0.069" JET SIZE NOZZLE (0008.5)	1/4"-MEG MNPT	15K psi (1034 bar)
15-013-012	0.071" JET SIZE NOZZLE (0009)	1/4"-MEG MNPT	15K psi (1034 bar)
15-013-013	0.075" JET SIZE NOZZLE (0010)	1/4"-MEG MNPT	15K psi (1034 bar)
15-013-014	0.078" JET SIZE NOZZLE (0011)	1/4"-MEG MNPT	15K psi (1034 bar)
15-013-015	0.082" JET SIZE NOZZLE (0012)	1/4"-MEG MNPT	15K psi (1034 bar)
15-013-016	0.085" JET SIZE NOZZLE (0013)	1/4"-MEG MNPT	15K psi (1034 bar)
15-013-017	0.093" JET SIZE NOZZLE (0015)	1/4"-MEG MNPT	15K psi (1034 bar)
15-013-018	0.095" JET SIZE NOZZLE (0016)	1/4"-MEG MNPT	15K psi (1034 bar)
15-013-019	0.100" JET SIZE NOZZLE (0018)	1/4"-MEG MNPT	15K psi (1034 bar)
15-013-020	0.106" JET SIZE NOZZLE (0020)	1/4"-MEG MNPT	15K psi (1034 bar)
15-013-021	0.118" JET SIZE NOZZLE (0025)	1/4"-MEG MNPT	15K psi (1034 bar)
15-013-022	0.130" JET SIZE NOZZLE (0030)	1/4"-MEG MNPT	15K psi (1034 bar)
15-013-023	0.140" JET SIZE NOZZLE (0035)	1/4"-MEG MNPT	15K psi (1034 bar)

1/2" NPT LONG HARD HITTER NOZZLES

1/2" NPT Long Hard Hitter Nozzles offer an elongated orifice that holds a pattern longer than some of the shorter nozzles on the market. Great for hand-held shotgunning as well as mechanical cleaning tools, such as shell-side machines and tower cleaners.



PART NO.	1/2" NPT LONG HARD HITTER NOZZLES	INLET	LENGTH	ORIFICE	MAX PRESSURE
15-036-125	SS GBS STYLE HARD HITTER NOZZLE	1/2" NPT	3"	0.125"	15K psi (1034 bar)
15-036-140	SS GBS STYLE HARD HITTER NOZZLE	1/2" NPT	3"	0.140"	15K psi (1034 bar)
15-036-156	SS GBS STYLE HARD HITTER NOZZLE	1/2" NPT	3"	0.156"	15K psi (1034 bar)
15-036-172	SS GBS STYLE HARD HITTER NOZZLE	1/2" NPT	3"	0.172"	15K psi (1034 bar)
15-036-187	SS GBS STYLE HARD HITTER NOZZLE	1/2" NPT	3"	0.187"	15K psi (1034 bar)
15-036-203	SS GBS STYLE HARD HITTER NOZZLE	1/2" NPT	3"	0.203"	15K psi (1034 bar)
15-036-219	SS GBS STYLE HARD HITTER NOZZLE	1/2" NPT	3"	0.219"	15K psi (1034 bar)
15-036-234	SS GBS STYLE HARD HITTER NOZZLE	1/2" NPT	3"	0.234"	15K psi (1034 bar)
15-036-250	SS GBS STYLE HARD HITTER NOZZLE	1/2" NPT	3"	0.250"	15K psi (1034 bar)
15-038-125	HARD HITTER NOZZLE	1/2" NPT	6"	0.125"	15K psi (1034 bar)
15-038-140	HARD HITTER NOZZLE	1/2" NPT	6"	0.140"	15K psi (1034 bar)
15-038-156	HARD HITTER NOZZLE	1/2" NPT	6"	0.156"	15K psi (1034 bar)
15-038-172	HARD HITTER NOZZLE	1/2" NPT	6"	0.172"	15K psi (1034 bar)
15-038-187	HARD HITTER NOZZLE	1/2" NPT	6"	0.187"	15K psi (1034 bar)
15-038-203	HARD HITTER NOZZLE	1/2" NPT	6"	0.203"	15K psi (1034 bar)
15-038-219	HARD HITTER NOZZLE	1/2" NPT	6"	0.219"	15K psi (1034 bar)
15-038-234	HARD HITTER NOZZLE	1/2" NPT	6"	0.234"	15K psi (1034 bar)
15-038-250	HARD HITTER NOZZLE	1/2" NPT	6"	0.250"	15K psi (1034 bar)

DROP-IN TUNGSTEN CARBIDE HARD HITTER NOZZLES

Our Drop-In Tungsten Carbide Hard Hitter Nozzles are compact inserts made to drop in to the typical quick-change nozzle holder body common to shotgun cleaning applications.

PART NO.	DROP-IN TUNGSTEN CARBIDE HARD HITTER NOZZLES	MAX PRESSURE
17-025-021	0.021" DROP-IN TUNGSTEN CARBIDE HARD HITTER NOZZLE	20K psi (1379 bar)
17-025-024	0.024" DROP-IN TUNGSTEN CARBIDE HARD HITTER NOZZLE (NOT AVAILABLE)	20K psi (1379 bar)
17-025-026	0.026" DROP-IN TUNGSTEN CARBIDE HARD HITTER NOZZLE	20K psi (1379 bar)
17-025-028	0.028" DROP-IN TUNGSTEN CARBIDE HARD HITTER NOZZLE	20K psi (1379 bar)
17-025-031	0.031" DROP-IN TUNGSTEN CARBIDE HARD HITTER NOZZLE (31F.031)	20K psi (1379 bar)
17-025-036	0.036" DROP-IN TUNGSTEN CARBIDE HARD HITTER NOZZLE	20K psi (1379 bar)
17-025-041	0.041" DROP-IN TUNGSTEN CARBIDE HARD HITTER NOZZLE (GDWJ TYPE: 77133011)	20K psi (1379 bar)
17-025-043	0.043" DROP-IN TUNGSTEN CARBIDE HARD HITTER NOZZLE (31F.043)	20K psi (1379 bar)
17-025-047	0.047" DROP-IN TUNGSTEN CARBIDE HARD HITTER NOZZLE	20K psi (1379 bar)
17-025-051	0.051" DROP-IN TUNGSTEN CARBIDE HARD HITTER NOZZLE	20K psi (1379 bar)
17-025-055	0.055" DROP-IN TUNGSTEN CARBIDE HARD HITTER NOZZLE	20K psi (1379 bar)
17-025-059	0.059" DROP-IN TUNGSTEN CARBIDE HARD HITTER NOZZLE	20K psi (1379 bar)
17-025-062	0.062" DROP-IN TUNGSTEN CARBIDE HARD HITTER NOZZLE	20K psi (1379 bar)
17-025-076	0.076" DROP-IN TUNGSTEN CARBIDE HARD HITTER NOZZLE	20K psi (1379 bar)

LARGE ULTRA-POLISHED NOZZLES & NOZZLE HOLDERS

Ultra-Polished Nozzles are to be used in high flow applications where a high cohesive straight jet of water is required for large cleaning applications. They are often used with shell-side cleaners but have many other uses.

Female and male threaded nozzle holder assemblies are available as well. The carbide insert comes in 12 different orifice sizes to suit your flow pressure requirements.

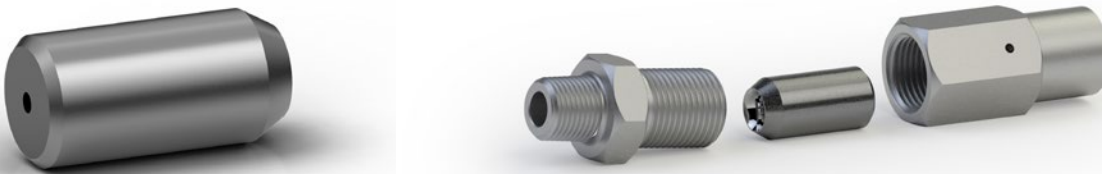

PART NO.	LARGE ULTRA-POLISHED NOZZLES & NOZZLE HOLDERS	INLET	MAX PRESSURE
15-035-062	0.062" LARGE ULTRA-POLISHED TUNGSTEN CARBIDE NOZZLE INSERT	1/2" NPT	15K psi (1034 bar)
15-035-071	0.071" LARGE ULTRA-POLISHED TUNGSTEN CARBIDE NOZZLE INSERT	1/2" NPT	15K psi (1034 bar)
15-035-078	0.078" LARGE ULTRA-POLISHED TUNGSTEN CARBIDE NOZZLE INSERT	1/2" NPT	15K psi (1034 bar)
15-035-083	0.083" LARGE ULTRA-POLISHED TUNGSTEN CARBIDE NOZZLE INSERT	1/2" NPT	15K psi (1034 bar)
15-035-089	0.089" LARGE ULTRA-POLISHED TUNGSTEN CARBIDE NOZZLE INSERT	1/2" NPT	15K psi (1034 bar)
15-035-093	0.093" LARGE ULTRA-POLISHED TUNGSTEN CARBIDE NOZZLE INSERT	1/2" NPT	15K psi (1034 bar)
15-035-109	0.109" LARGE ULTRA-POLISHED TUNGSTEN CARBIDE NOZZLE INSERT	1/2" NPT	15K psi (1034 bar)
15-035-125	0.125" LARGE ULTRA-POLISHED TUNGSTEN CARBIDE NOZZLE INSERT	1/2" NPT	15K psi (1034 bar)
15-035-140	0.140" LARGE ULTRA-POLISHED TUNGSTEN CARBIDE NOZZLE INSERT	1/2" NPT	15K psi (1034 bar)
15-035-156	0.156" LARGE ULTRA-POLISHED TUNGSTEN CARBIDE NOZZLE INSERT	1/2" NPT	15K psi (1034 bar)
15-035-166	0.166" LARGE ULTRA-POLISHED TUNGSTEN CARBIDE NOZZLE INSERT	1/2" NPT	15K psi (1034 bar)
15-035-172	0.172" LARGE ULTRA-POLISHED TUNGSTEN CARBIDE NOZZLE INSERT	1/2" NPT	15K psi (1034 bar)
30-009-016	2-016 TEFLON O-RING	--	15K psi (1034 bar)
15-035-000	ULTRA-POLISHED NOZZLE HOLDER ASSEMBLY	1/2" NPTF	15K psi (1034 bar)
15-035-003	ULTRA-POLISHED NOZZLE HOLDER ASSEMBLY	1/2" NPTM	15K psi (1034 bar)
15-035-006	ULTRA-POLISHED NOZZLE HOLDER ASSEMBLY W/O GLAND NUT & COLLAR	9/16" MPF	15K psi (1034 bar)

LARGE TUNGSTEN CARBIDE NOZZLE ASSEMBLIES & INSERTS

Large Tungsten Carbide Nozzle Assemblies are to be used in high flow applications where a solid stream of water is required for big cleaning jobs, such as in paper mills, power plants, tube bundle cleaning, tank cleaning, and reactor vessels.

The 3/4" threaded NPT nozzle holders come in a standard 2-3/4" long assembly and are also available in a shorter 2-1/8" long holder. The carbide inserts come in 11 different orifice sizes to suit your applications.

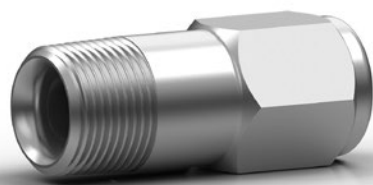

PART NO.	LARGE TC NOZZLE ASSEMBLIES & INSERTS	INLET	ORIFICE	MAX PRESSURE
15-028-109	LARGE TUNGSTEN CARBIDE NOZZLE ASSEMBLY (#21)	3/4" NPT	0.109"	15K psi (1034 bar)
15-028-125	LARGE TUNGSTEN CARBIDE NOZZLE ASSEMBLY (#27)	3/4" NPT	0.125"	15K psi (1034 bar)
15-028-140	LARGE TUNGSTEN CARBIDE NOZZLE ASSEMBLY (#35)	3/4" NPT	0.140"	15K psi (1034 bar)
15-028-156	LARGE TUNGSTEN CARBIDE NOZZLE ASSEMBLY (#40)	3/4" NPT	0.156"	15K psi (1034 bar)
15-028-165	LARGE TUNGSTEN CARBIDE NOZZLE ASSEMBLY (#50)	3/4" NPT	0.165"	15K psi (1034 bar)
15-028-172	LARGE TUNGSTEN CARBIDE NOZZLE ASSEMBLY (#52)	3/4" NPT	0.172"	15K psi (1034 bar)
15-028-187	LARGE TUNGSTEN CARBIDE NOZZLE ASSEMBLY (#60)	3/4" NPT	0.187"	15K psi (1034 bar)
15-028-203	LARGE TUNGSTEN CARBIDE NOZZLE ASSEMBLY (#70)	3/4" NPT	0.203"	15K psi (1034 bar)
15-028-218	LARGE TUNGSTEN CARBIDE NOZZLE ASSEMBLY (#90)	3/4" NPT	0.218"	15K psi (1034 bar)
15-028-250	LARGE TUNGSTEN CARBIDE NOZZLE ASSEMBLY (#100)	3/4" NPT	0.250"	15K psi (1034 bar)
15-028-312	LARGE TUNGSTEN CARBIDE NOZZLE ASSEMBLY	3/4" NPT	0.312"	15K psi (1034 bar)
15-027-109	TUNGSTEN CARBIDE NOZZLE REPLACEMENT INSERT	F/ 3/4" NPT	0.109"	15K psi (1034 bar)
15-027-125	TUNGSTEN CARBIDE NOZZLE REPLACEMENT INSERT	F/ 3/4" NPT	0.125"	15K psi (1034 bar)
15-027-140	TUNGSTEN CARBIDE NOZZLE REPLACEMENT INSERT	F/ 3/4" NPT	0.140"	15K psi (1034 bar)
15-027-156	TUNGSTEN CARBIDE NOZZLE REPLACEMENT INSERT	F/ 3/4" NPT	0.156"	15K psi (1034 bar)
15-027-165	TUNGSTEN CARBIDE NOZZLE REPLACEMENT INSERT	F/ 3/4" NPT	0.165"	15K psi (1034 bar)
15-027-172	TUNGSTEN CARBIDE NOZZLE REPLACEMENT INSERT	F/ 3/4" NPT	0.172"	15K psi (1034 bar)
15-027-187	TUNGSTEN CARBIDE NOZZLE REPLACEMENT INSERT	F/ 3/4" NPT	0.187"	15K psi (1034 bar)
15-027-203	TUNGSTEN CARBIDE NOZZLE REPLACEMENT INSERT	F/ 3/4" NPT	0.203"	15K psi (1034 bar)
15-027-218	TUNGSTEN CARBIDE NOZZLE REPLACEMENT INSERT	F/ 3/4" NPT	0.218"	15K psi (1034 bar)
15-027-250	TUNGSTEN CARBIDE NOZZLE REPLACEMENT INSERT	F/ 3/4" NPT	0.250"	15K psi (1034 bar)
15-027-312	TUNGSTEN CARBIDE NOZZLE REPLACEMENT INSERT	F/ 3/4" NPT	0.312"	15K psi (1034 bar)

STAINLESS STEEL FAN TIP MNPT NOZZLES

Stainless Steel Fan Tip Nozzles bring exceptional power to control gun surface cleaning applications. They are available in 15° and 25°, made from hardened stainless steel, and feature male NPT threads and wrench flats for easy installation.



PART NO.	ANGLE	ORIFICE	STAINLESS STEEL FAN TIP MNPT NOZZLES	INLET	MAX PRESSURE
15-014-000	15°	0.026"	STAINLESS STEEL FAN TIP MNPT NOZZLE (1501)	1/4" NPT	15K psi (1034 bar)
15-014-001	15°	0.036"	STAINLESS STEEL FAN TIP MNPT NOZZLE (1502)	1/4" NPT	15K psi (1034 bar)
15-014-002	15°	0.043"	STAINLESS STEEL FAN TIP MNPT NOZZLE (1503)	1/4" NPT	15K psi (1034 bar)
15-014-003	15°	0.046"	STAINLESS STEEL FAN TIP MNPT NOZZLE (1504)	1/4" NPT	15K psi (1034 bar)
15-014-004	15°	0.050"	STAINLESS STEEL FAN TIP MNPT NOZZLE (1504.5)	1/4" NPT	15K psi (1034 bar)
15-014-005	15°	0.052"	STAINLESS STEEL FAN TIP MNPT NOZZLE (1505)	1/4" NPT	15K psi (1034 bar)
15-014-006	15°	0.055"	STAINLESS STEEL FAN TIP MNPT NOZZLE (1505.5)	1/4" NPT	15K psi (1034 bar)
15-014-007	15°	0.059"	STAINLESS STEEL FAN TIP MNPT NOZZLE (1506)	1/4" NPT	15K psi (1034 bar)
15-014-008	15°	0.060"	STAINLESS STEEL FAN TIP MNPT NOZZLE (1506.5)	1/4" NPT	15K psi (1034 bar)
15-014-009	15°	0.062"	STAINLESS STEEL FAN TIP MNPT NOZZLE (1507)	1/4" NPT	15K psi (1034 bar)
15-014-010	15°	0.065"	STAINLESS STEEL FAN TIP MNPT NOZZLE (1507.5)	1/4" NPT	15K psi (1034 bar)
15-014-011	15°	0.067"	STAINLESS STEEL FAN TIP MNPT NOZZLE (1508)	1/4" NPT	15K psi (1034 bar)
15-014-012	15°	0.073"	STAINLESS STEEL FAN TIP MNPT NOZZLE (1508.5)	1/4" NPT	15K psi (1034 bar)
15-014-013	15°	0.075"	STAINLESS STEEL FAN TIP MNPT NOZZLE (1509)	1/4" NPT	15K psi (1034 bar)
15-014-015	15°	0.075"	STAINLESS STEEL FAN TIP MNPT NOZZLE (1510)	1/4" NPT	15K psi (1034 bar)
15-014-016	15°	0.077"	STAINLESS STEEL FAN TIP MNPT NOZZLE (1510.5)	1/4" NPT	15K psi (1034 bar)
15-014-017	15°	0.078"	STAINLESS STEEL FAN TIP MNPT NOZZLE (1511)	1/4" NPT	15K psi (1034 bar)
15-014-018	15°	0.080"	STAINLESS STEEL FAN TIP MNPT NOZZLE (1511.5)	1/4" NPT	15K psi (1034 bar)
15-014-019	15°	0.082"	STAINLESS STEEL FAN TIP MNPT NOZZLE (1512)	1/4" NPT	15K psi (1034 bar)
15-014-020	15°	0.084"	STAINLESS STEEL FAN TIP MNPT NOZZLE (1512.5)	1/4" NPT	15K psi (1034 bar)
15-014-021	15°	0.085"	STAINLESS STEEL FAN TIP MNPT NOZZLE (1513)	1/4" NPT	15K psi (1034 bar)
15-014-022	15°	0.089"	STAINLESS STEEL FAN TIP MNPT NOZZLE (1514)	1/4" NPT	15K psi (1034 bar)
15-014-023	15°	0.093"	STAINLESS STEEL FAN TIP MNPT NOZZLE (1515)	1/4" NPT	15K psi (1034 bar)
15-014-024	15°	0.095"	STAINLESS STEEL FAN TIP MNPT NOZZLE (1516)	1/4" NPT	15K psi (1034 bar)
15-014-025	15°	0.100"	STAINLESS STEEL FAN TIP MNPT NOZZLE (1518)	1/4" NPT	15K psi (1034 bar)
15-014-026	15°	0.106"	STAINLESS STEEL FAN TIP MNPT NOZZLE (1520)	1/4" NPT	15K psi (1034 bar)
15-014-027	15°	0.118"	STAINLESS STEEL FAN TIP MNPT NOZZLE (1525)	1/4" NPT	15K psi (1034 bar)
15-014-028	15°	0.130"	STAINLESS STEEL FAN TIP MNPT NOZZLE (1530)	1/4" NPT	15K psi (1034 bar)
15-014-029	15°	0.140"	STAINLESS STEEL FAN TIP MNPT NOZZLE (1535)	1/4" NPT	15K psi (1034 bar)

STAINLESS STEEL FAN TIP MNPT NOZZLES*(Continued)*

PART NO.	ANGLE	ORIFICE	STAINLESS STEEL FAN TIP MNPT NOZZLES	INLET	MAX PRESSURE
15-015-001	25°	0.036"	STAINLESS STEEL FAN TIP MNPT NOZZLE (2502)	1/4" NPT	15K psi (1034 bar)
15-015-002	25°	0.043"	STAINLESS STEEL FAN TIP MNPT NOZZLE (2503)	1/4" NPT	15K psi (1034 bar)
15-015-003	25°	0.046"	STAINLESS STEEL FAN TIP MNPT NOZZLE (2504)	1/4" NPT	15K psi (1034 bar)
15-015-004	25°	0.050"	STAINLESS STEEL FAN TIP MNPT NOZZLE (2504.5)	1/4" NPT	15K psi (1034 bar)
15-015-005	25°	0.052"	STAINLESS STEEL FAN TIP MNPT NOZZLE (2505)	1/4" NPT	15K psi (1034 bar)
15-015-006	25°	0.055"	STAINLESS STEEL FAN TIP MNPT NOZZLE (2505.5)	1/4" NPT	15K psi (1034 bar)
15-015-007	25°	0.059"	STAINLESS STEEL FAN TIP MNPT NOZZLE (2506)	1/4" NPT	15K psi (1034 bar)
15-015-008	25°	0.060"	STAINLESS STEEL FAN TIP MNPT NOZZLE (2506.5)	1/4" NPT	15K psi (1034 bar)
15-015-009	25°	0.062"	STAINLESS STEEL FAN TIP MNPT NOZZLE (2507)	1/4" NPT	15K psi (1034 bar)
15-015-010	25°	0.065"	STAINLESS STEEL FAN TIP MNPT NOZZLE (2507.5)	1/4" NPT	15K psi (1034 bar)
15-015-011	25°	0.067"	STAINLESS STEEL FAN TIP MNPT NOZZLE (2508)	1/4" NPT	15K psi (1034 bar)
15-015-012	25°	0.069"	STAINLESS STEEL FAN TIP MNPT NOZZLE (2508.5)	1/4" NPT	15K psi (1034 bar)
15-015-013	25°	0.071"	STAINLESS STEEL FAN TIP MNPT NOZZLE (2509)	1/4" NPT	15K psi (1034 bar)
15-015-014	25°	0.073"	STAINLESS STEEL FAN TIP MNPT NOZZLE (2509.5)	1/4" NPT	15K psi (1034 bar)
15-015-015	25°	0.075"	STAINLESS STEEL FAN TIP MNPT NOZZLE (2510)	1/4" NPT	15K psi (1034 bar)
15-015-016	25°	0.077"	STAINLESS STEEL FAN TIP MNPT NOZZLE (2510.5)	1/4" NPT	15K psi (1034 bar)
15-015-017	25°	0.078"	STAINLESS STEEL FAN TIP MNPT NOZZLE (2511)	1/4" NPT	15K psi (1034 bar)
15-015-018	25°	0.080"	STAINLESS STEEL FAN TIP MNPT NOZZLE (2511.5)	1/4" NPT	15K psi (1034 bar)
15-015-019	25°	0.082"	STAINLESS STEEL FAN TIP MNPT NOZZLE (2512)	1/4" NPT	15K psi (1034 bar)
15-015-020	25°	0.084"	STAINLESS STEEL FAN TIP MNPT NOZZLE (2512.5)	1/4" NPT	15K psi (1034 bar)
15-015-021	25°	0.085"	STAINLESS STEEL FAN TIP MNPT NOZZLE (2513)	1/4" NPT	15K psi (1034 bar)
15-015-022	25°	0.089"	STAINLESS STEEL FAN TIP MNPT NOZZLE (2514)	1/4" NPT	15K psi (1034 bar)
15-015-023	25°	0.093"	STAINLESS STEEL FAN TIP MNPT NOZZLE (2515)	1/4" NPT	15K psi (1034 bar)
15-015-024	25°	0.095"	STAINLESS STEEL FAN TIP MNPT NOZZLE (2516)	1/4" NPT	15K psi (1034 bar)
15-015-025	25°	0.100"	STAINLESS STEEL FAN TIP MNPT NOZZLE (2518)	1/4" NPT	15K psi (1034 bar)
15-015-026	25°	0.106"	STAINLESS STEEL FAN TIP MNPT NOZZLE (2520)	1/4" NPT	15K psi (1034 bar)
15-015-027	25°	0.118"	STAINLESS STEEL FAN TIP MNPT NOZZLE (2525)	1/4" NPT	15K psi (1034 bar)
15-015-028	25°	0.130"	STAINLESS STEEL FAN TIP MNPT NOZZLE (2530)	1/4" NPT	15K psi (1034 bar)
15-015-029	25°	0.140"	STAINLESS STEEL FAN TIP MNPT NOZZLE (2535)	1/4" NPT	15K psi (1034 bar)

TUNGSTEN CARBIDE 15° & 25° FAN TIP MNPT NOZZLES

Our Tungsten Carbide Fan Tip Nozzles bring exceptional power to control gun surface cleaning applications. They are available in 15° & 25°, made from hardened stainless steel inserted with tungsten carbide orifice, and feature male NPT threads and wrench flats for easy installation.



PART NO.	ANGLE	ORIFICE	TUNGSTEN CARBIDE FAN TIP MNPT NOZZLES	INLET	MAX PRESSURE
15-016-001	15°	0.036"	TUNGSTEN CARBIDE FAN TIP MNPT NOZZLE (1502)	1/4" NPT	15K psi (1034 bar)
15-016-002	15°	0.043"	TUNGSTEN CARBIDE FAN TIP MNPT NOZZLE (1503)	1/4" NPT	15K psi (1034 bar)
15-016-003	15°	0.046"	TUNGSTEN CARBIDE FAN TIP MNPT NOZZLE (1504)	1/4" NPT	15K psi (1034 bar)
15-016-005	15°	0.052"	TUNGSTEN CARBIDE FAN TIP MNPT NOZZLE (1505)	1/4" NPT	15K psi (1034 bar)
15-016-007	15°	0.059"	TUNGSTEN CARBIDE FAN TIP MNPT NOZZLE (1506)	1/4" NPT	15K psi (1034 bar)
15-016-009	15°	0.062"	TUNGSTEN CARBIDE FAN TIP MNPT NOZZLE (1507)	1/4" NPT	15K psi (1034 bar)
15-016-011	15°	0.067"	TUNGSTEN CARBIDE FAN TIP MNPT NOZZLE (1508)	1/4" NPT	15K psi (1034 bar)
15-016-013	15°	0.071"	TUNGSTEN CARBIDE FAN TIP MNPT NOZZLE (1509)	1/4" NPT	15K psi (1034 bar)
15-016-015	15°	0.075"	TUNGSTEN CARBIDE FAN TIP MNPT NOZZLE (1510)	1/4" NPT	15K psi (1034 bar)
15-016-017	15°	0.078"	TUNGSTEN CARBIDE FAN TIP MNPT NOZZLE (1511)	1/4" NPT	15K psi (1034 bar)
15-016-019	15°	0.082"	TUNGSTEN CARBIDE FAN TIP MNPT NOZZLE (1512)	1/4" NPT	15K psi (1034 bar)
15-016-023	15°	0.093"	TUNGSTEN CARBIDE FAN TIP MNPT NOZZLE (1515)	1/4" NPT	15K psi (1034 bar)
15-017-001	25°	0.036"	TUNGSTEN CARBIDE FAN TIP MNPT NOZZLE (2502)	1/4" NPT	15K psi (1034 bar)
15-017-002	25°	0.043"	TUNGSTEN CARBIDE FAN TIP MNPT NOZZLE (2503)	1/4" NPT	15K psi (1034 bar)
15-017-003	25°	0.046"	TUNGSTEN CARBIDE FAN TIP MNPT NOZZLE (2504)	1/4" NPT	15K psi (1034 bar)
15-017-005	25°	0.052"	TUNGSTEN CARBIDE FAN TIP MNPT NOZZLE (2505)	1/4" NPT	15K psi (1034 bar)
15-017-007	25°	0.059"	TUNGSTEN CARBIDE FAN TIP MNPT NOZZLE (2506)	1/4" NPT	15K psi (1034 bar)
15-017-009	25°	0.062"	TUNGSTEN CARBIDE FAN TIP MNPT NOZZLE (2507)	1/4" NPT	15K psi (1034 bar)
15-017-011	25°	0.067"	TUNGSTEN CARBIDE FAN TIP MNPT NOZZLE (2508)	1/4" NPT	15K psi (1034 bar)
15-017-013	25°	0.071"	TUNGSTEN CARBIDE FAN TIP MNPT NOZZLE (2509)	1/4" NPT	15K psi (1034 bar)
15-017-015	25°	0.075"	TUNGSTEN CARBIDE FAN TIP MNPT NOZZLE (2510)	1/4" NPT	15K psi (1034 bar)
15-017-017	25°	0.078"	TUNGSTEN CARBIDE FAN TIP MNPT NOZZLE (2511)	1/4" NPT	15K psi (1034 bar)
15-017-023	25°	0.093"	TUNGSTEN CARBIDE FAN TIP MNPT NOZZLE (2515)	1/4" NPT	15K psi (1034 bar)

DROP-IN TUNGSTEN CARBIDE FAN TIP NOZZLES & CONTROL GUN NOZZLE HOLDERS

Drop-In Tungsten Carbide Fan Tip Nozzles are compact inserts made to drop in to the typical quick-change nozzle holder body common to shotgun cleaning applications.

Our quick-change Control Gun Nozzle Holders accommodate the Tungsten Carbide Drop-In Tips common to shotgun cleaning applications. Simply unscrew the cap and drop in the appropriate nozzle for the job.



PART NO.	DROP-IN TC FAN TIP NOZZLES & NOZZLE HOLDERS	INLET	ORIFICE	MAX PRESSURE
17-026-021	DROP-IN TUNGSTEN CARBIDE HIGH IMPACT FAN TIP NOZZLE (11F.021-5")	--	0.021"	20K psi (1379 bar)
17-026-024	DROP-IN TUNGSTEN CARBIDE HIGH IMPACT FAN TIP NOZZLE	--	0.024"	20K psi (1379 bar)
17-026-026	DROP-IN TUNGSTEN CARBIDE HIGH IMPACT FAN TIP NOZZLE	--	0.026"	20K psi (1379 bar)
17-026-028	DROP-IN TUNGSTEN CARBIDE HIGH IMPACT FAN TIP NOZZLE	--	0.028"	20K psi (1379 bar)
17-026-031	DROP-IN TUNGSTEN CARBIDE HIGH IMPACT FAN TIP NOZZLE (11F1.5-3E)	--	0.031"	20K psi (1379 bar)
17-026-036	DROP-IN TUNGSTEN CARBIDE HIGH IMPACT FAN TIP NOZZLE	--	0.036"	20K psi (1379 bar)
17-026-041	DROP-IN TUNGSTEN CARBIDE HIGH IMPACT FAN TIP NOZZLE (11F2.5-5E)	--	0.041"	20K psi (1379 bar)
17-026-043	DROP-IN TUNGSTEN CARBIDE HIGH IMPACT FAN TIP NOZZLE (11F3.0-5E)	--	0.043"	20K psi (1379 bar)
17-026-047	DROP-IN TUNGSTEN CARBIDE HIGH IMPACT FAN TIP NOZZLE (21F3.5-5E)	--	0.047"	20K psi (1379 bar)
17-026-051	DROP-IN TUNGSTEN CARBIDE HIGH IMPACT FAN TIP NOZZLE	--	0.051"	20K psi (1379 bar)
17-026-055	DROP-IN TUNGSTEN CARBIDE HIGH IMPACT FAN TIP NOZZLE	--	0.055"	20K psi (1379 bar)
17-026-059	DROP-IN TUNGSTEN CARBIDE HIGH IMPACT FAN TIP NOZZLE	--	0.059"	20K psi (1379 bar)
17-026-062	DROP-IN TUNGSTEN CARBIDE HIGH IMPACT FAN TIP NOZZLE	--	0.062"	20K psi (1379 bar)
17-026-067	DROP-IN TUNGSTEN CARBIDE HIGH IMPACT FAN TIP NOZZLE	--	0.067"	20K psi (1379 bar)
17-026-075	DROP-IN TUNGSTEN CARBIDE HIGH IMPACT FAN TIP NOZZLE (21F9.0-7E)	--	0.075"	20K psi (1379 bar)
17-025-000	CONTROL GUN NOZZLE HOLDER ASSEMBLY W/O GLAND NUT & COLLAR	9/16" MP	--	20K psi (1379 bar)
17-025-001	CONTROL GUN NOZZLE HOLDER CAP	9/16" MP	--	20K psi (1379 bar)
17-025-002	CONTROL GUN NOZZLE HOLDER BODY	9/16" MP	--	20K psi (1379 bar)
30-001-010	2-010 BUNA-N 90 DURO O-RING (GDWJ TYPE: 22-09212)	--	--	20K psi (1379 bar)

SAND EDUCTOR NOZZLES

APS proudly offers Sand Eductor Nozzles.



PART NO.	ORIFICE	SAND EDUCTOR NOZZLES	INLET	MAX PRESSURE
15-012-000	--	ABRASIVE SAND EDUCTOR ASSEMBLY W/O 1/4" NPT MEG	1/2" NPT	15K psi (1034 bar)
15-012-001	--	ABRASIVE SAND EDUCTOR INLET ADAPTER / NOZZLE HOLDER	--	15K psi (1034 bar)
15-012-002	--	ABRASIVE SAND EDUCTOR HOUSING	--	15K psi (1034 bar)
15-012-003	0.187"	ABRASIVE TUNGSTEN CARBIDE NOZZLE SAND EDUCTOR	--	15K psi (1034 bar)
15-012-004	0.250"	ABRASIVE TUNGSTEN CARBIDE NOZZLE SAND EDUCTOR	--	15K psi (1034 bar)
15-012-005	0.312"	ABRASIVE TUNGSTEN CARBIDE NOZZLE SAND EDUCTOR	--	15K psi (1034 bar)
15-012-006	0.375"	ABRASIVE TUNGSTEN CARBIDE NOZZLE SAND EDUCTOR	--	15K psi (1034 bar)
20-200-001	--	ELL, 45° PLATED, STREET	1/2" NPT	15K psi (1034 bar)
30-001-910	--	3-910 BUNA-N 90 DURO O-RING	--	15K psi (1034 bar)

CARRIER NOZZLES

Our Carrier Nozzles are ideal for the Cobra Control Gun, as they are available with 2-5 ports. Inlet ports are 9/16" HP Cone or Button, and nozzle ports are usually 3/8"-24.



PART NO.	CARRIER NOZZLES	O.D.	MAX PRESSURE
17-005-001	HIGH PRODUCTION 4-JET (OFFSET) STAINLESS STEEL CARRIER NOZZLE (3126)	1.990"	40K psi (2758 bar)
17-005-007	HIGH PRODUCTION 4-JET (EQUALLY SPACED 24° INCLUDED) STAINLESS STEEL CARRIER NOZZLE (3144-4)	1.490"	40K psi (2758 bar)
17-005-008	HIGH PRODUCTION 5-JET (EQUALLY SPACED 24° INCLUDED) STAINLESS STEEL CARRIER NOZZLE (3144-5)	1.490"	40K psi (2758 bar)
17-005-136	9/16" UH RH (F) BUTTON X 2-3/8"-24 JETS @ B (20° INCLUDED) CARRIER NOZZLE	--	40K psi (2758 bar)
17-005-137	9/16" UH RH (F) BUTTON X 2-3/8"-24 JETS @ B (30° INCLUDED 5" PATTERN @ 6" AWAY) CARRIER NOZZLE	--	40K psi (2758 bar)
17-005-138	1.990" O.D. X 3-3/8" LONG X 9/16" UHF BUTTON X 3 JETS @ 30° (INCLUDED ANGLE JEWELLED EQUALLY SPACED) STAINLESS STEEL CARRIER NOZZLE (J/S TYPE: 53970)	1.990"	40K psi (2758 bar)

RADIAL PANCAKE NOZZLE ASSEMBLIES

We offer a wide variety of sizes in Pancake Style Nozzles for tube cleaning applications. Each is made of hardened stainless steel, features four (4) jets @ 90° that use high pressure sapphire inserts, and the cut-outs on the 3" and above save a great deal of added weight. The largest is 6" wide.

Please specify orifice size, pressure and flow when ordering.



PART NO.	RADIAL PANCAKE NOZZLE ASSEMBLIES	INLET	DIAMETER	MAX PRESSURE
17-010-001	STAINLESS STEEL 90° RADIAL PANCAKE (4 JETS @ C)	9/16" UHF BUTTON	2"	40K psi (2758 bar)
17-010-002	STAINLESS STEEL 90° RADIAL PANCAKE (4 JETS @ C)	9/16" UHF BUTTON	4"	40K psi (2758 bar)
17-010-003	STAINLESS STEEL 90° RADIAL PANCAKE (4 JETS @ C)	9/16" UHF BUTTON	5"	40K psi (2758 bar)

NPTM to NPTF REDUCER BUSHINGS

Specifically designed for water blasting service, these high quality Reducer Bushings are made from heavy duty stainless steel because of its reliability and durability.

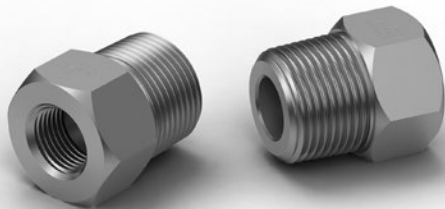

PART NO.	NPTM TO NPTF REDUCER BUSHINGS	INLET	OUTLET	MAX PRESSURE
20-010-017	REDUCER BUSHING	1-1/4" NPTM	1" NPTF	10K psi (690 bar)
20-010-014	REDUCER BUSHING	1" NPTM	1/2" NPTF	12K psi (827 bar)
20-010-015	REDUCER BUSHING	1" NPTM	3/4" NPTF	12K psi (827 bar)
20-010-016	REDUCER BUSHING	1" NPTM	3/8" NPTF	12K psi (827 bar)
20-010-001	REDUCER BUSHING	1/8" NPTM	1/16" NPTF	15K psi (1034 bar)
20-010-002	REDUCER BUSHING	1/4" NPTM	1/16" NPTF	15K psi (1034 bar)
20-010-003	REDUCER BUSHING	1/4" NPTM	1/8" NPTF	15K psi (1034 bar)
20-010-004	REDUCER BUSHING	3/8" NPTM	1/16" NPTF	15K psi (1034 bar)
20-010-005	REDUCER BUSHING	3/8" NPTM	1/8" NPTF	15K psi (1034 bar)
20-010-006	REDUCER BUSHING (GDWJ TYPE: 77203006)	3/8" NPTM	1/4" NPTF	15K psi (1034 bar)
20-010-007	REDUCER BUSHING (GDWJ TYPE: 77203007)	1/2" NPTM	1/16" NPTF	15K psi (1034 bar)
20-010-008	REDUCER BUSHING (GDWJ TYPE: 77203008)	1/2" NPTM	1/8" NPTF	15K psi (1034 bar)
20-010-009	REDUCER BUSHING	1/2" NPTM	1/4" NPTF	15K psi (1034 bar)
20-010-010	REDUCER BUSHING (GDWJ TYPE: 77203010)	1/2" NPTM	3/8" NPTF	15K psi (1034 bar)
20-010-011	REDUCER BUSHING (GDWJ TYPE: 77203017)	3/4" NPTM	1/4" NPTF	15K psi (1034 bar)
20-010-012	REDUCER BUSHING	3/4" NPTM	3/8" NPTF	15K psi (1034 bar)
20-010-013	REDUCER BUSHING	3/4" NPTM	1/2" NPTF	15K psi (1034 bar)

AUTOCLAVE STYLE REDUCER BUSHINGS w/ GLAND NUTS & COLLARS

These Stainless Steel Bushings are also available without gland nuts and collars upon request.



PART NO.	REDUCER BUSHINGS	INLET	OUTLET	MAX PRESSURE
21-007-156	REDUCER BUSHING W/O GLAND NUT & COLLAR	3/4" MPF	M36 X 2	20K psi (1379 bar)
21-008-001	REDUCER BUSHING W/ GLAND NUT & COLLAR	3/8" MPM	1/4" MPF	20K psi (1379 bar)
21-008-002	REDUCER BUSHING W/ GLAND NUT & COLLAR	9/16" MPM	1/4" MPF	20K psi (1379 bar)
21-008-003	REDUCER BUSHING W/ GLAND NUT & COLLAR	9/16" MPM	3/8" MPF	20K psi (1379 bar)
21-008-004	REDUCER BUSHING W/ GLAND NUT & COLLAR	9/16" MPM	9/16" MPF	20K psi (1379 bar)
21-008-005	REDUCER BUSHING W/ GLAND NUT & COLLAR	3/4" MPM	3/8" MPF	20K psi (1379 bar)
21-008-006	REDUCER BUSHING W/ GLAND NUT & COLLAR	3/4" MPM	9/16" MPF	20K psi (1379 bar)
21-008-007	TORPEDO REDUCER BUSHING W/ GLAND NUT & COLLAR	1" MPM	9/16" MPF	20K psi (1379 bar)
21-008-008	REDUCER BUSHING W/ GLAND NUT & COLLAR	1" MPM	3/4" MPF	20K psi (1379 bar)
21-008-009	REDUCER BUSHING W/ GLAND NUT & COLLAR	9/16" MPM	1" MPF	20K psi (1379 bar)

MP-MALE to NPT REDUCER BUSHINGS

Specifically designed for water blasting service, these high quality Reducer Bushings are made from heavy duty stainless steel because of its reliability and durability.



PART NO.	MP-MALE TO NPT REDUCER BUSHINGS	INLET	OUTLET	MAX PRESSURE
20-020-027	NLB TYPE ADAPTER	1-3/8" MPM (1-3/4"-12)	1" NPTM	12K psi (827 bar)
20-020-020	STAINLESS STEEL ADAPTER	1/4" MPM	1/8" NPTM	15K psi (1034 bar)
20-020-021	STAINLESS STEEL ADAPTER W/ GLAND NUT & COLLAR	3/4" MPF	1/2" NPTM	15K psi (1034 bar)
20-020-022	STAINLESS STEEL COUPLING W/ GLAND NUT & COLLAR	3/4" MPF	1/2" NPTF	15K psi (1034 bar)
20-020-023	TORPEDO ADAPTER W/ GLAND NUT & COLLAR	3/4" MPM	1/2" NPTM	15K psi (1034 bar)
20-020-024	TORPEDO ADAPTER W/ GLAND NUT & COLLAR	3/4" MPM	1/2" NPTF	15K psi (1034 bar)
20-020-025	TORPEDO ADAPTER W/ GLAND NUT & COLLAR	1" MP	1/2" NPTF	15K psi (1034 bar)
20-020-026	NLB TYPE ADAPTER	1-3/8" MPM (1-3/4"-12)	3/4" NPTM	15K psi (1034 bar)
20-020-028	STAINLESS STEEL COUPLING W/ GLAND NUT & COLLAR	3/4" MPF	1" NPTF	15K psi (1034 bar)

BSPP x NPT BUSHINGS

Stainless Steel Male x Female Bushings in BSPP x NPT.



PART NO.	BSPP X NPT BUSHINGS	INLET	OUTLET	MAX PRESSURE
20-026-043	SLIMLINE BUSHING	3/8" BSPPM	1/16" NPTF	15K psi (1034 bar)
20-026-044	SLIMLINE BUSHING	3/8" BSPPM	1/8" NPTF	15K psi (1034 bar)
20-026-045	SLIMLINE BUSHING	3/8" BSPPM	1/4" NPTF	15K psi (1034 bar)
20-026-053	STAINLESS STEEL HEX STYLE REDUCER BUSHING	3/8" BSPPM	1/16" NPTF	15K psi (1034 bar)
20-026-054	STAINLESS STEEL HEX STYLE REDUCER BUSHING	3/8" BSPPM	1/8" NPTF	15K psi (1034 bar)
20-026-055	STAINLESS STEEL HEX STYLE REDUCER BUSHING (FACE SEAL)	3/8" BSPPM	1/4" NPTF	15K psi (1034 bar)
20-026-068	REDUCER BUSHING	3/8" NPTM	1/4" BSPPF	15K psi (1034 bar)
21-007-075	STAINLESS STEEL BUSHING	1/4" NPTF	M24 x 1.5M DKO	15K psi (1034 bar)
21-007-156	STAINLESS STEEL REDUCER BUSHING W/O GLAND NUT & COLLAR	3/4" MPF	M36 x 2	20K psi (1379 bar)

SWAGE ADAPTERS

Our Stainless Steel Swage Adapters offer a male thread of a smaller diameter and a female thread of a larger diameter.



PART NO.	SWAGE ADAPTERS	INLET	OUTLET	MAX PRESSURE
20-009-005	SWAGE ADAPTER	1" NPTF	1/2" NPTM	12K psi (827 bar)
20-009-006	SWAGE ADAPTER	1" NPTF	3/4" NPTM	12K psi (827 bar)
20-001-009	STAINLESS STEEL SLIMLINE SWAGE ADAPTER	5/16"-24 UH RHF	1/4"-28 MMS	15K psi (1034 bar)
20-009-001	SLIMLINE SWAGE ADAPTER	1/8" NPTF	1/16" NPTM	15K psi (1034 bar)
20-009-002	STAINLESS STEEL SWAGE ADAPTER	1/2" NPTF	1/4" NPTM	15K psi (1034 bar)
20-009-003	STAINLESS STEEL SWAGE ADAPTER	1/2" NPTF	3/8" NPTM	15K psi (1034 bar)
20-009-004	SWAGE ADAPTER	3/4" NPTF	1/2" NPTM	15K psi (1034 bar)

METRIC / BSPP to NPT ADAPTERS

Advanced Pressure Systems offers NPT, Metric, and BSPP fittings for all your connect needs. If what you need is not listed, please call and ask.

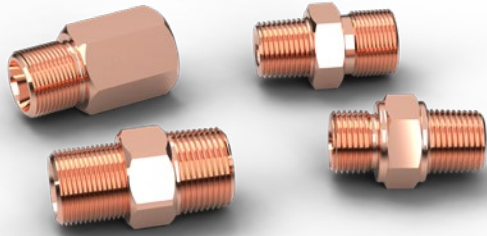

PART NO.	METRIC / BSPP TO NPT ADAPTERS	INLET	OUTLET	MAX PRESSURE
20-026-003	ADAPTER W/ 60° ENTRY CONE	1/2" NPTM	1/2" BSPPM	15K psi (1034 bar)
20-026-007	STAINLESS STEEL ADAPTER W/ 24° (INCLUDED SEAT)	3/4" NPTM	M36 x 2M	15K psi (1034 bar)
20-026-009	STAINLESS STEEL ADAPTER	1/2" NPTM	M22 x 1.5M	15K psi (1034 bar)
20-026-010	ADAPTER W/ O-RING	1/2" BSPPF	1/2" BSPPF	15K psi (1034 bar)
20-026-011	ADAPTER W/ O-RING	1/2" BSPPF	M24 x 1.5M	15K psi (1034 bar)
20-026-001	ADAPTER W/ 24° (INCLUDED CONE)	1/2" NPTM	M24 x 1.5M	16K psi (1103 bar)
20-026-002	ADAPTER	1/2" NPTF	M24 x 1.5M	16K psi (1103 bar)
20-026-004	ADAPTER W/ 60° INLET	1/2" NPTF	1/2" BSPPM	16K psi (1103 bar)
20-026-006	STAINLESS STEEL ADAPTER	3/4" NPTM	M24 x 1.5 DKO (MN)	16K psi (1103 bar)
20-026-008	STAINLESS STEEL ADAPTER	M36 x 2M	M36 x 2M	23K psi (1586 bar)
20-026-031	ADAPTER (M24 X 1.5 THREADED LENGTH 0.866")	M24 x 1.5M DKO	M24 x 1.5M DKO	26K psi (1793 bar)

TYPE M x NPT (M) ADAPTERS

Stainless Steel Male x Male Adapters allow for connecting Type M and NPT female threaded components.



PART NO.	TYPE M X NPT (M) ADAPTERS	INLET	OUTLET	MAX PRESSURE
20-019-005	ADAPTER	1" NPTM	13MM (1"-12) TYPE M	12K psi (827 bar)
20-019-008	ADAPTER	1" NPTM	20MM (1-5/16"-12) TYPE M	12K psi (827 bar)
20-019-025	STAINLESS STEEL ADAPTER	1" NPTM	5MM (9/16"-18) TYPE M	12K psi (827 bar)
20-019-026	ADAPTER	1" NPTM	8MM (3/4"-16) TYPE M	12K psi (827 bar)
20-019-001	STAINLESS STEEL ADAPTER (GDWJ TYPE: 77211009)	1/2" NPTM	5MM (9/16"-18) TYPE M	15K psi (1034 bar)
20-019-002	STAINLESS STEEL ADAPTER	1/2" NPTM	8MM (3/4"-16) TYPE M	15K psi (1034 bar)
20-019-003	STAINLESS STEEL ADAPTER (HMM16-NM8) (GDWJ TYPE: 77211012)	1/2" NPTM	13MM (1"-12) TYPE M	15K psi (1034 bar)
20-019-004	STAINLESS STEEL ADAPTER	3/4" NPTM	13MM (1"-12) TYPE M	15K psi (1034 bar)
20-019-006	ADAPTER	1/2" NPTM	20MM (1-5/16"-12) TYPE M	15K psi (1034 bar)
20-019-007	ADAPTER	3/4" NPTM	20MM (1-5/16"-12) TYPE M	15K psi (1034 bar)
20-019-009	ADAPTER	1/4" NPTM	5MM (9/16"-18) TYPE M	15K psi (1034 bar)
20-019-010	ADAPTER	3/8" NPTM	5MM (9/16"-18) TYPE M	15K psi (1034 bar)
20-019-011	ADAPTER	3/8" NPTM	13MM (1"-12) TYPE M	15K psi (1034 bar)
20-019-015	STAINLESS STEEL ADAPTER	3/4" NPTM	8MM (3/4"-16) TYPE M	15K psi (1034 bar)
20-019-019	ADAPTER	3/4" NPTM	5MM (9/16"-18) TYPE M	15K psi (1034 bar)
20-019-020	ADAPTER	1/4" NPTM	8MM (3/4"-16) TYPE M	15K psi (1034 bar)
20-019-021	STAINLESS STEEL ADAPTER	3/8" NPTM	8MM (3/4"-16) TYPE M	15K psi (1034 bar)
20-019-027	STAINLESS STEEL ADAPTER	3/8" NPTM	20MM (1-5/16"-12) TYPE M	15K psi (1034 bar)

ADAPTERS MP (M) x NPT (M)

These Stainless Steel Male x Male Adapters allow for connecting Medium Pressure (MP) and NPT female threaded components.



PART NO.	ADAPTERS MP (M) X NPT (M)	INLET	OUTLET	MAX PRESSURE
20-020-004	ADAPTER	3/4" MPM	1" NPTM	12K psi (827 bar)
20-020-007	STAINLESS STEEL ADAPTER	1" MPM	1" NPTM	12K psi (827 bar)
20-020-010	TORPEDO ADAPTER W/ GLAND NUT & COLLAR	1" MPM	1" NPTM	12K psi (827 bar)
20-020-001	STAINLESS STEEL ADAPTER (GDWJ TYPE: 77211032)	9/16" MPM	1/2" NPTM	15K psi (1034 bar)
20-020-002	STAINLESS STEEL ADAPTER (GDWJ TYPE: 77211027)	3/4" MPM	1/2" NPTM	15K psi (1034 bar)
20-020-003	ADAPTER	3/4" MPM	3/4" NPTM	15K psi (1034 bar)
20-020-005	STAINLESS STEEL ADAPTER	1" MPM	1/2" NPTM	15K psi (1034 bar)
20-020-006	STAINLESS STEEL ADAPTER	1" MPM	3/4" NPTM	15K psi (1034 bar)
20-020-008	STAINLESS STEEL TORPEDO ADAPTER W/ GLAND NUT & COLLAR	1" MPM	1/2" NPTM	15K psi (1034 bar)
20-020-009	TORPEDO ADAPTER W/ GLAND NUT & COLLAR	1" MPM	3/4" NPTM	15K psi (1034 bar)

ADAPTERS METRIC (M) x NPT (M)

Stainless Steel Male x Male Adapters allow for connecting Metric and NPT female threaded components.

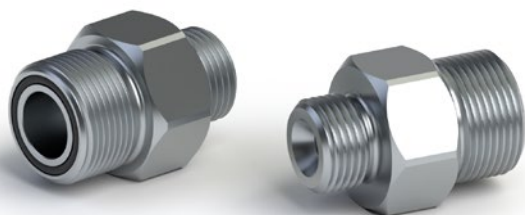

PART NO.	ADAPTERS METRIC (M) X NPT (M)	INLET	OUTLET	MAX PRESSURE
20-026-039	STAINLESS STEEL ADAPTER	1" NPTM	M36 X 2M	12K psi (827 bar)
20-026-019	ADAPTER	3/8" NPTF	M24 X 1.5M	15K psi (1034 bar)
20-026-020	ADAPTER	1/4" NPTF	M24 X 1.5M	15K psi (1034 bar)
20-026-032	STAINLESS STEEL ADAPTER W/ FACE SEAL	1/2" NPTF	M33 X 2M	15K psi (1034 bar)
20-026-033	STAINLESS STEEL ADAPTER W/ FACE SEAL	3/4" NPTF	M33 X 2M	15K psi (1034 bar)
20-026-034	STAINLESS STEEL ADAPTER (60° INCLUDED CONE)	1/2" BSPPM	1/2" BSPPM	15K psi (1034 bar)
20-026-035	STAINLESS STEEL ADAPTER (60° INCLUDED CONE)	3/8" BSPPM	3/8" BSPPM	15K psi (1034 bar)
20-026-038	ADAPTER (60° INCLUDED CONE) W/ O-RING	1/2" BSPPM	M24 X 1.5	15K psi (1034 bar)
20-026-042	STAINLESS STEEL ADAPTER	1/2" NPTM	M36 X 2M	15K psi (1034 bar)
20-026-049	STAINLESS STEEL ADAPTER W/ FACE SEAL	3/8" NPTM	M22 X 1.5M	15K psi (1034 bar)
20-026-066	STAINLESS STEEL ADAPTER (60° FEMALE CONE)	1/2" NPTM	3/8 BSPPM	15K psi (1034 bar)
20-026-067	STAINLESS STEEL ADAPTER (60° FEMALE CONE)	3/8" NPTM	3/8 BSPPM	15K psi (1034 bar)
21-007-059	ADAPTER (24° INCLUDED SEAT) (M24 X 1.5 - 0.866" LONG)	3/4" MPM	M24 X 1.5M	15K psi (1034 bar)
21-007-039	STAINLESS STEEL ADAPTER (24° FLARE)	3/8" HPM (3/4"-16)	M42 X 2M	17.4K psi (1200 bar)
21-007-041	STAINLESS STEEL ADAPTER	M42 X 2	M42 X 2	17.4K psi (1200 bar)
21-007-064	ADAPTER (GDWJ TYPE: 77211099)	7/8"-14 TYPE M	9/16"-18 TYPE M	17.4K psi (1200 bar)
20-026-014	STAINLESS STEEL ADAPTER W/ FACE SEAL	1-5/16"-12F	M33 X 2M	20K psi (1379 bar)
20-026-015	STAINLESS STEEL ADAPTER W/ FACE SEAL	1-5/16"-12 TYPE M	M33 X 2M	20K psi (1379 bar)
20-026-016	STAINLESS STEEL ADAPTER W/O FACE SEAL	1"-12 TYPE M	M33 X 2M	20K psi (1379 bar)
20-026-036	STAINLESS STEEL ADAPTER	1"-12 TYPE M	M33 X 2M	20K psi (1379 bar)
20-026-037	STAINLESS STEEL ADAPTER W/ FACE SEAL	1-5/16"-12 TYPE M	M33 X 2M	20K psi (1379 bar)
21-007-042	ADAPTER (24° INCLUDED SEAT)	1" MPM	M36 X 2 TYPE M	20K psi (1379 bar)
21-007-056	STAINLESS STEEL ADAPTER (24° INCLUDED SEAT)	3/4" MPM	M36 X 2 TYPE M	20K psi (1379 bar)
21-007-060	STAINLESS STEEL ADAPTER	9/16" MPM (13/16"-16)	M36 X 2 DKO	20K psi (1379 bar)
21-007-066	STAINLESS STEEL ADAPTER W/ 24° FEMALE CONE	3/8" HPM	G-1/4 BSPPM	20K psi (1379 bar)
21-007-067	STAINLESS STEEL ADAPTER	9/16" HPM	3/8" MPM	20K psi (1379 bar)
21-007-068	STAINLESS STEEL ADAPTER W/ 24° FEMALE CONE	3/8" MPM	G-1/4 BSPPM	20K psi (1379 bar)
21-007-069	STAINLESS STEEL ADAPTER W/ 60° FEMALE CONE	9/16"-18 TYPE M	G-1/4 BSPPM	20K psi (1379 bar)
21-007-071	STAINLESS STEEL ADAPTER W/ 24° FEMALE CONE	1" MPM	M24 X 1.5 TYPE M	20K psi (1379 bar)
21-007-074	STAINLESS STEEL ADAPTER W/ 60° FEMALE CONE	9/16" MPM	G-1/4 BSPPM	20K psi (1379 bar)
21-007-077	ADAPTER (USED W/ BRASS OR COPPER WASHER)	33/64" TYPE M	M36 X 2	20K psi (1379 bar)
21-007-040	STAINLESS STEEL ADAPTER W/ 24° FLARE	3/8" HPM (3/4"-16)	M36 X 2M	20.3K psi (1400 bar)
21-007-061	STAINLESS STEEL ADAPTER	M24 X 1.5	M36 X 2	24K psi (1655 bar)
20-026-031	STAINLESS STEEL ADAPTER (0.866" LENGTH)	M24 X 1.5M DKO	M24 X 1.5M DKO	26K psi (1793 bar)

ADAPTERS MP-MALE x MP-MALE

These Male x Male Adapters are made from stainless steel.



PART NO.	ADAPTERS MP-MALE X MP-MALE	INLET	OUTLET	MAX PRESSURE
21-007-023	STAINLESS STEEL ADAPTER	9/16" MPM	3/4" MPM	20K psi (1379 bar)
21-007-024	STAINLESS STEEL ADAPTER	9/16" MPM	1" MPM	20K psi (1379 bar)
21-007-025	STAINLESS STEEL ADAPTER	3/4" MPM	1" MPM	20K psi (1379 bar)
21-007-026	ADAPTER	9/16" MPM	9/16" MPM	20K psi (1379 bar)
21-007-027	ADAPTER	3/4" MPM	3/4" MPM	20K psi (1379 bar)
21-007-045	ADAPTER	3/8" MPM	3/8" MPM	20K psi (1379 bar)
21-007-063	TORPEDO ADAPTER W/ GLAND NUT & COLLAR	1" MPM	9/16" MPM	20K psi (1379 bar)
21-007-114	TORPEDO ADAPTER W/O GLAND NUT & COLLAR	1" MPM	1-5/16"-12 TYPE M MALE	20K psi (1379 bar)
21-007-173	TORPEDO ADAPTER W/O GLAND NUT & COLLAR	1" MPM	9/16"-18 TYPE M MALE	20K psi (1379 bar)
21-007-028	STAINLESS STEEL ADAPTER	1" MPM	1" MPM	21K psi (1448 bar)

AUTOCLAVE STYLE SINGLE PIECE ADAPTERS MP x TYPE M

Stainless Steel Autoclave Adapters are commonly used to connect high pressure polyflex hoses with Type M female swivels to assemblies, such as foot operated dump guns, air diverter valves and hand-held control guns.

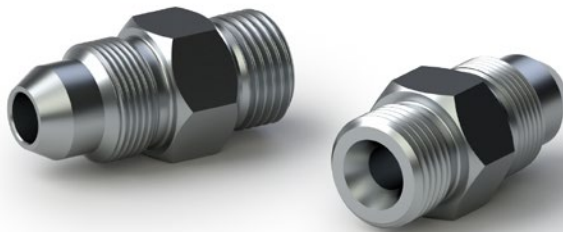

PART NO.	SINGLE PIECE ADAPTERS	INLET	OUTLET	MAX PRESSURE
21-007-001	ADAPTER	3/8" MPM	5MM (9/16"-18) TYPE M MALE	20K psi (1379 bar)
21-007-002	ADAPTER (AF 061-M6)	3/8" MPM	8MM (3/4"-16) TYPE M MALE	20K psi (1379 bar)
21-007-003	ADAPTER (GDWJ TYPE: 77211022)	9/16" MPM	5MM (9/16"-18) TYPE M MALE	20K psi (1379 bar)
21-007-004	STAINLESS STEEL ADAPTER (AF 061-MP9) (GDWJ TYPE: 77211023)	9/16" MPM	8MM (3/4"-16) TYPE M MALE	20K psi (1379 bar)
21-007-005	ADAPTER (GDWJ TYPE: 77211024)	9/16" MPM	13MM (1"-12) TYPE M MALE	20K psi (1379 bar)
21-007-006	ADAPTER (GDWJ TYPE: 77211035)	3/4" MPM	5MM (9/16"-18) TYPE M MALE	20K psi (1379 bar)
21-007-007	ADAPTER (GDWJ TYPE: 77211025)	3/4" MPM	8MM (3/4"-16) TYPE M MALE	20K psi (1379 bar)
21-007-008	ADAPTER (GDWJ TYPE: 77211026)	3/4" MPM	13MM (1"-12) TYPE M MALE	20K psi (1379 bar)
21-007-009	ADAPTER (GDWJ TYPE: 77211060) (M16-MP16)	1" MPM	13MM (1"-12) TYPE M MALE	20K psi (1379 bar)
21-007-010	ADAPTER	1" MPM	20MM (1-5/16"-12) TYPE M MALE	20K psi (1379 bar)
21-007-034	STAINLESS STEEL ADAPTER	9/16" MPM	20MM (1-5/16"-12) TYPE M MALE	20K psi (1379 bar)
21-007-044	ADAPTER	3/4" MPM	7/8" (7/8"-14) TYPE M MALE	20K psi (1379 bar)

TUBE ADAPTERS

These male by female bushings are used to connect components with female Jetstream lance connection to the industry standard male left-handed medium pressure tubing connections without the use of glands and collars.



PART NO.	TUBE ADAPTERS	INLET	OUTLET	O.D.	MAX PRESSURE
21-016-001	SLIMLINE TUBE ADAPTER (J/S TYPE: 54176)	1/4" MP LHF	1/4" MP RHM	--	20K psi (1379 bar)
21-016-002	SLIMLINE TUBE ADAPTER (J/S TYPE: 54174)	3/8" MP LHF	3/8" MP RHM	--	20K psi (1379 bar)
21-016-003	SLIMLINE TUBE ADAPTER (J/S TYPE: 52552)	9/16" MP LHF	9/16" MP RHM	--	20K psi (1379 bar)
21-016-004	SLIMLINE TUBE ADAPTER	3/8" MP RHF	1/4" MP RHM	0.468"	20K psi (1379 bar)
21-016-005	SLIMLINE TUBE ADAPTER	9/16" MP LHF	9/16" MP RHM	--	20K psi (1379 bar)
21-016-006	SLIMLINE TUBE ADAPTER	9/16" MP RHF	9/16" MP LHM	--	20K psi (1379 bar)
21-016-007	SLIMLINE TUBE ADAPTER	3/8" MP LHM	9/16" MP LHM	--	20K psi (1379 bar)
21-016-008	SLIMLINE TUBE ADAPTER	1/4" MP RHF	1/4" MP LHM	0.375"	20K psi (1379 bar)
21-016-010	STAINLESS STEEL LANCE CLOSE NIPPLE (J/S TYPE: 53221)	9/16"-18 RHM	9/16"-18 RHM	--	20K psi (1379 bar)
21-016-011	STAINLESS STEEL LANCE CLOSE NIPPLE	9/16"-18 RHM	9/16"-18 LHM	--	20K psi (1379 bar)
21-016-012	STAINLESS STEEL LANCE CLOSE NIPPLE (J/S TYPE: 52088)	3/8"-24 RHM	3/8"-24 RHM	--	20K psi (1379 bar)
21-016-013	STAINLESS STEEL LANCE CLOSE NIPPLE (J/S TYPE: 53149)	9/16"-18 RHM	3/8"-24 RHM	--	20K psi (1379 bar)
21-016-014	STAINLESS STEEL LANCE CLOSE NIPPLE (J/S TYPE: 54792)	9/16"-18 RHM	1/4"-28 RHM	--	20K psi (1379 bar)
21-016-015	STAINLESS STEEL LANCE CLOSE NIPPLE (J/S TYPE: 52521)	3/8"-24 RHM	1/4"-28 RHM	--	20K psi (1379 bar)
21-016-016	STAINLESS STEEL LANCE CLOSE NIPPLE (J/S TYPE: 52437)	1/4"-28 RHM	1/4"-28 RHM	--	20K psi (1379 bar)
21-016-017	SLIMLINE TUBE ADAPTER	1/4" HP LHF	3/8" MP LHM	0.468"	20K psi (1379 bar)
21-016-018	SLIMLINE TUBE ADAPTER	3/8"-24 RHF	3/8" MP LHM	0.500"	20K psi (1379 bar)

ANTI-VIBRATION GLANDS

A less complex and more economical design than other vibration-resistant connections, the collet gland assembly utilizes the same coned-and-threaded features of the medium pressure connections. It extends the gland nut to provide room for the tapered slotted collet.

The design provides a slight difference in angles between the collet and the corresponding taper of the gland nut. As the nut is tightened, it acts to wedge the tapered end of the collet in to a gripping engagement with the tubing.

Material: Type 316 stainless steel.

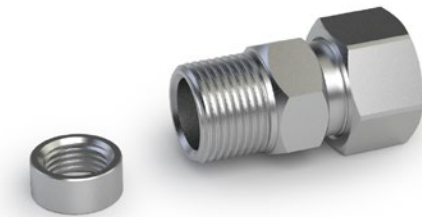

PART NO.	ANTI-VIBRATION GLANDS	INLET	MAX PRESSURE
21-005-001	ANTI-VIBE COLLET ASSEMBLY W/ COLLAR	1/4" MP	20K psi (1379 bar)
21-005-002	ANTI-VIBE COLLET ASSEMBLY W/ COLLAR	3/8" MP	20K psi (1379 bar)
21-005-003	ANTI-VIBE COLLET ASSEMBLY W/ COLLAR	9/16" MP	20K psi (1379 bar)
21-005-004	ANTI-VIBE COLLET ASSEMBLY (SPLIT COLLAR, LH COLLAR , BODY & NUT)	3/4" MP	20K psi (1379 bar)
21-005-005	ANTI-VIBE COLLET ASSEMBLY W/O COLLAR	1" MP	20K psi (1379 bar)

AUTOCLAVE STYLE 90° MP ELBOWS & TEES

Elbows and Tees are made from stainless steel. Versions without gland nuts and collars also available.



PART NO.	AUTOCLAVE STYLE 90° MP ELBOWS & TEES	INLET	MAX PRESSURE
21-009-001	90° MEDIUM PRESSURE ELBOW W/ GLAND NUTS & COLLARS	1/4" MP	20K psi (1379 bar)
21-009-002	90° MEDIUM PRESSURE ELBOW W/ GLAND NUTS & COLLARS	3/8" MP	20K psi (1379 bar)
21-009-003	90° MEDIUM PRESSURE ELBOW W/ GLAND NUTS & COLLARS	9/16" MP	20K psi (1379 bar)
21-009-004	90° MEDIUM PRESSURE ELBOW W/ GLAND NUTS & COLLARS	3/4" MP	20K psi (1379 bar)
21-009-005	90° MEDIUM PRESSURE ELBOW W/ GLAND NUTS & COLLARS	1" MP	20K psi (1379 bar)
21-010-001	90° MEDIUM PRESSURE TEE W/ GLAND NUTS & COLLARS	1/4" MP	20K psi (1379 bar)
21-010-002	90° MEDIUM PRESSURE TEE W/ GLAND NUTS & COLLARS	3/8" MP	20K psi (1379 bar)
21-010-003	90° MEDIUM PRESSURE TEE W/ GLAND NUTS & COLLARS	9/16" MP	20K psi (1379 bar)
21-010-005	90° MEDIUM PRESSURE TEE W/ GLAND NUTS & COLLARS	3/4" MP	20K psi (1379 bar)
21-010-004	90° MEDIUM PRESSURE TEE W/ GLAND NUTS & COLLARS	1" MP	22.5K psi (1551 bar)

GLAND NUTS & COLLARS

Manufactured specifically for water blasting service, these fitting are made from heavy duty stainless steel because of its reliability and durability.



PART NO.	GLAND NUTS & COLLARS	INLET	MAX PRESSURE
21-003-001	MEDIUM PRESSURE GLAND NUT (AF 070-MP4)	1/4" MP	20K psi (1379 bar)
21-003-002	MEDIUM PRESSURE GLAND NUT (AF 070-MP6)	3/8" MP	20K psi (1379 bar)
21-003-003	MEDIUM PRESSURE GLAND NUT (AF 070-MP9)	9/16" MP	20K psi (1379 bar)
21-003-004	MEDIUM PRESSURE GLAND NUT (AF 070-MP12)	3/4" MP	20K psi (1379 bar)
21-003-005	MEDIUM PRESSURE GLAND NUT (AF 070-MP16)	1" MP	20K psi (1379 bar)
21-002-001	MEDIUM PRESSURE COLLAR (AF 071-MP4)	1/4" MP	20K psi (1379 bar)
21-002-002	MEDIUM PRESSURE COLLAR (AF 071-MP6)	3/8" MP	20K psi (1379 bar)
21-002-003	MEDIUM PRESSURE COLLAR (AF 071-MP9)	9/16" MP	20K psi (1379 bar)
21-002-004	MEDIUM PRESSURE COLLAR (AF 071-MP12)	3/4" MP	20K psi (1379 bar)
21-002-005	MEDIUM PRESSURE COLLAR (AF 071-MP16)	1" MP	20K psi (1379 bar)
21-002-103	MEDIUM PRESSURE COLLAR (AF 071-MP9-RH)	9/16" MP RH	20K psi (1379 bar)

HOSE CONNECTORS

These Type M Male x Type M Male lance couplers are made from heavy duty stainless steel specifically for water blasting service.



PART NO.	HOSE CONNECTORS	INLET	OUTLET	MAX PRESSURE
21-007-016	ADAPTER (J/S TYPE: 28196)	8MM (3/4" -16) TYPE M	8MM (3/4" -16) TYPE M	20K psi (1379 bar)
21-007-018	ADAPTER	20MM (1-5/16"-12) TYPE M	20MM (1-5/16"-12) TYPE M	20K psi (1379 bar)
21-007-022	ADAPTER (M21 X M16)	13MM (1"-12) TYPE M	20MM (1-5/16"-12) TYPE M	20K psi (1379 bar)
21-007-030	ADAPTER	5MM (9/16"-18) TYPE M	13MM (1"-12) TYPE M	20K psi (1379 bar)
21-007-017	STAINLESS STEEL ADAPTER (GDWJ TYPE: 77211003) (J/S TYPE: 29061)	13MM (1"-12) TYPE M	13MM (1"-12) TYPE M	26K psi (1793 bar)
21-007-020	ADAPTER	5MM (9/16"-18) TYPE M	8MM (3/4"-16) TYPE M	30K psi (2068 bar)
21-007-021	ADAPTER (J/S TYPE: 28101)	8MM (3/4"-16) TYPE M	13MM (1"-12) TYPE M	30K psi (2068 bar)
21-007-043	ADAPTER	7/8" (7/8"-14) TYPE M	13MM (1"-12) TYPE M	30K psi (2068 bar)
21-007-015	STAINLESS STEEL ADAPTER (GDWJ TYPE: 77211001)	5MM (9/16"-18) TYPE M	5MM (9/16"-18)	40K psi (2758 bar)

UNF LANCE CONNECTORS

Slimline Connectors rated for 15K psi are primarily used on rotary lance machines when downgrading from 20K and 40K psi to 15K psi applications.



PART NO.	UNF LANCE CONNECTORS	INLET	OUTLET	O.D.	MAX PRESSURE
20-027-001	SLIMLINE COUPLING	9/16" MP LH	1/16" NPT	0.687"	15K psi (1034 bar)
20-027-002	SLIMLINE COUPLING	9/16" MP LH	1/8" NPT	0.687"	15K psi (1034 bar)
20-027-003	STAINLESS STEEL SLIMLINE COUPLING	9/16" MP LH	1/4" NPT	0.750"	15K psi (1034 bar)
20-027-004	SLIMLINE COUPLING	9/16" MP RH	1/16" NPT	0.687"	15K psi (1034 bar)
20-027-005	SLIMLINE COUPLING	9/16" MP RH	1/8" NPT	0.750"	15K psi (1034 bar)
20-027-006	SLIMLINE COUPLING	9/16" MP RH	1/4" NPT	0.750"	15K psi (1034 bar)
20-027-007	SLIMLINE COUPLING	9/16" HP LH	1/16" NPT	0.750"	15K psi (1034 bar)
20-027-008	SLIMLINE COUPLING	9/16" HP LH	1/8" NPT	0.750"	15K psi (1034 bar)
20-027-009	SLIMLINE COUPLING	9/16" HP LH	1/4" NPT	0.750"	15K psi (1034 bar)
20-027-010	SLIMLINE COUPLING	9/16" HP RH	1/16" NPT	0.750"	15K psi (1034 bar)

SOCKET HEAD PLUGS & HEX HEAD PLUGS

Stainless Steel Socket Head Pipe Plugs are available in sizes from 1/16" NPT to 1/2" NPT for pressures up to 15K psi MAWP. A 3/4" size is also available for pressures up to 10K psi MAWP.

Manufactured specifically for water blasting service, Hex Head Plugs are made from stainless steel because of its reliability and durability.



PART NO.	SOCKET HEAD PLUGS & HEX HEAD PLUGS	INLET	MAX PRESSURE
15-075-000	STAINLESS STEEL SOCKET HEAD PIPE PLUG	3/4" NPT	10K psi (690 bar)
15-018-000	STAINLESS STEEL LINE MOLE JET SOCKET HEAD PIPE PLUG (GDWJ TYPE: 77118006)	1/4" NPT	15K psi (1034 bar)
15-037-000	STAINLESS STEEL SOCKET HEAD PIPE PLUG	3/8" NPT	15K psi (1034 bar)
15-050-000	STAINLESS STEEL SOCKET HEAD PIPE PLUG	1/2" NPT	15K psi (1034 bar)
15-118-000	STAINLESS STEEL LINE MOLE JET SOCKET HEAD PIPE PLUG	1/8" NPT	15K psi (1034 bar)
15-218-000	STAINLESS STEEL LINE MOLE JET PLUG	1/16" NPT	15K psi (1034 bar)
20-018-008	STAINLESS STEEL HEX HEAD PLUG	1-1/4" NPT	10K psi (690 bar)
20-018-007	STAINLESS STEEL HEX HEAD PLUG	1" NPT	12K psi (827 bar)
20-018-001	STAINLESS STEEL HEX HEAD PLUG	1/16" NPT	15K psi (1034 bar)
20-018-002	STAINLESS STEEL HEX HEAD PLUG	1/8" NPT	15K psi (1034 bar)
20-018-003	STAINLESS STEEL HEX HEAD PLUG	1/4" NPT	15K psi (1034 bar)
20-018-004	STAINLESS STEEL HEX HEAD PLUG	3/8" NPT	15K psi (1034 bar)
20-018-005	STAINLESS STEEL HEX HEAD PLUG	1/2" NPT	15K psi (1034 bar)
20-018-006	STAINLESS STEEL HEX HEAD PLUG	3/4" NPT	15K psi (1034 bar)

PLUGS

These plugs should be paired with their matching sized gland nut located on page 71.



PART NO.	PLUGS	INLET	MAX PRESSURE
21-004-001	MEDIUM PRESSURE PLUG	1/4" MP	20K psi (1379 bar)
21-004-002	MEDIUM PRESSURE PLUG	3/8" MP	20K psi (1379 bar)
21-004-003	MEDIUM PRESSURE PLUG	9/16" MP	20K psi (1379 bar)
21-004-004	MEDIUM PRESSURE PLUG	3/4" MP	20K psi (1379 bar)
21-004-005	MEDIUM PRESSURE PLUG	1" MP	20K psi (1379 bar)

HEAVY DUTY COUPLINGS

Stainless Steel Heavy Duty Couplings are used for connecting a wide range of hoses. These are robust fittings are capable of withstanding the most demanding working conditions.



PART NO.	HEAVY DUTY COUPLINGS	INLET	OUTLET	MAX PRESSURE
20-005-018	HEAVY DUTY COUPLING	1-1/4" NPTF	1-1/4" NPTF	10K psi (690 bar)
20-005-019	STAINLESS STEEL HEAVY DUTY COUPLING	1-1/4" NPTF	1" NPTF	10K psi (690 bar)
20-005-014	HEAVY DUTY COUPLING	1" NPTF	1/2" NPTF	12K psi (827 bar)
20-005-015	HEAVY DUTY COUPLING	1" NPTF	3/4" NPTF	12K psi (827 bar)
20-005-016	HEAVY DUTY COUPLING	1" NPTF	1" NPTF	12K psi (827 bar)
20-005-001	HEAVY DUTY COUPLING	1/4" NPTF	1/8" NPTF	15K psi (1034 bar)
20-005-002	HEAVY DUTY COUPLING	1/4" NPTF	1/4" NPTF	15K psi (1034 bar)
20-005-003	HEAVY DUTY COUPLING	3/8" NPTF	1/8" NPTF	15K psi (1034 bar)
20-005-004	HEAVY DUTY COUPLING (J/S TYPE: 26061)	3/8" NPTF	1/4" NPTF	15K psi (1034 bar)
20-005-005	HEAVY DUTY COUPLING (GDWJ TYPE: 77202005)	3/8" NPTF	3/8" NPTF	15K psi (1034 bar)
20-005-006	HEAVY DUTY COUPLING	1/2" NPTF	1/16" NPTF	15K psi (1034 bar)
20-005-007	HEAVY DUTY COUPLING	1/2" NPTF	1/8" NPTF	15K psi (1034 bar)
20-005-008	HEAVY DUTY COUPLING	1/2" NPTF	1/4" NPTF	15K psi (1034 bar)
20-005-009	HEAVY DUTY COUPLING	1/2" NPTF	3/8" NPTF	15K psi (1034 bar)
20-005-010	HEAVY DUTY COUPLING (GDWJ TYPE: 77202008)	1/2" NPTF	1/2" NPTF	15K psi (1034 bar)
20-005-011	HEAVY DUTY COUPLING	3/4" NPTF	1/4" NPTF	15K psi (1034 bar)
20-005-012	HEAVY DUTY COUPLING	3/4" NPTF	1/2" NPTF	15K psi (1034 bar)
20-005-013	HEAVY DUTY COUPLING	3/4" NPTF	3/4" NPTF	15K psi (1034 bar)
20-005-017	HEAVY DUTY COUPLING	1/8" NPTF	1/8" NPTF	15K psi (1034 bar)
20-005-020	HEAVY DUTY COUPLING	3/4" NPTF	3/8" NPTF	15K psi (1034 bar)

MP x NPT SLIMLINE COUPLINGS

Slimline Couplings rated for 15K psi are primarily used on rotary lance machines when downgrading from 20K psi and 40K psi to 15K psi applications.



PART NO.	MP X NPT SLIMLINE COUPLINGS	INLET	OUTLET	O.D.	MAX PRESSURE
20-027-001	SLIMLINE COUPLING	9/16" MP LH	1/16" NPT	0.687"	15K psi (1034 bar)
20-027-002	SLIMLINE COUPLING	9/16" MP LH	1/8" NPT	0.687"	15K psi (1034 bar)
20-027-003	STAINLESS STEEL SLIMLINE COUPLING	9/16" MP LH	1/4" NPT	0.750"	15K psi (1034 bar)
20-027-004	SLIMLINE COUPLING	9/16" MP RH	1/16" NPT	0.687"	15K psi (1034 bar)
20-027-005	SLIMLINE COUPLING	9/16" MP RH	1/8" NPT	0.750"	15K psi (1034 bar)
20-027-006	SLIMLINE COUPLING	9/16" MP RH	1/4" NPT	0.750"	15K psi (1034 bar)
20-027-007	SLIMLINE COUPLING	9/16" HP LH	1/16" NPT	0.750"	15K psi (1034 bar)
20-027-008	SLIMLINE COUPLING	9/16" HP LH	1/8" NPT	0.750"	15K psi (1034 bar)
20-027-009	SLIMLINE COUPLING	9/16" HP LH	1/4" NPT	0.750"	15K psi (1034 bar)
20-027-010	SLIMLINE COUPLING	9/16" HP RH	1/16" NPT	0.750"	15K psi (1034 bar)
20-027-011	SLIMLINE COUPLING	9/16" HP RH	1/8" NPT	0.750"	15K psi (1034 bar)
20-027-012	STAINLESS STEEL SLIMLINE COUPLING	9/16" HP RH	1/4" NPT	0.750"	15K psi (1034 bar)
20-027-013	SLIMLINE COUPLING	9/16" MP LH	3/8" NPT	0.875"	15K psi (1034 bar)

SLIMLINE COUPLINGS

Slimline Couplings are available up to 40K psi. Check the different O.D.'s for your tube cleaning application.

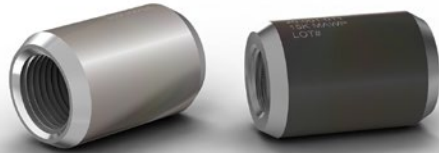

PART NO.	SLIMLINE COUPLINGS	INLET	OUTLET	O.D.	MAX PRESSURE
20-001-001	STAINLESS STEEL SLIMLINE COUPLING (GDWJ TYPE: 77201004)	1/16" NPT	1/16" NPT	0.375"	10K psi (690 bar)
20-001-002	SLIMLINE COUPLING (GDWJ TYPE: 77201001)	1/8" NPT	1/8" NPT	0.468"	10K psi (690 bar)
20-001-003	SLIMLINE COUPLING	1/8" NPT	1/4" NPT	0.625"	10K psi (690 bar)
20-001-004	SLIMLINE COUPLING (GDWJ TYPE: 77201002)	1/4" NPT	1/4" NPT	0.625"	10K psi (690 bar)
20-001-006	SLIMLINE COUPLING (GDWJ TYPE: 77201005)	1/2" NPT	1/2" NPT	1.125"	10K psi (690 bar)
20-001-011	SLIMLINE COUPLING	1/2" NPT	3/8" NPT	1.125"	10K psi (690 bar)
20-001-031	SLIMLINE COUPLING	3/8" NPT	3/8" NPT	0.813"	10K psi (690 bar)
20-001-007	SLIMLINE COUPLING	3/4" NPT	3/4" NPT	1.500"	12K psi (827 bar)
20-001-005	SLIMLINE COUPLING (GDWJ TYPE: 77201003) (J/S TYPE: 26057)	3/8" NPT	3/8" NPT	0.875"	15K psi (1034 bar)
20-001-008	SLIMLINE COUPLING (J/S TYPE: 52676)	1" NPT	1" NPT	2.000"	15K psi (1034 bar)
20-001-101	STAINLESS STEEL SLIMLINE COUPLING	1/16" NPT	1/16" NPT	0.406"	15K psi (1034 bar)
20-001-102	SLIMLINE COUPLING	1/8" NPT	1/8" NPT	0.500"	15K psi (1034 bar)
20-001-104	SLIMLINE COUPLING (J/S TYPE: 50816)	1/4" NPT	1/4" NPT	0.750"	15K psi (1034 bar)
20-001-106	SLIMLINE COUPLING (J/S TYPE: 26056)	1/2" NPT	1/2" NPT	1.187"	15K psi (1034 bar)
21-013-001	SLIMLINE COUPLING (GDWJ TYPE: 77513112) (COUNTERBORE REMOVED FROM ONE END)	1/4" MP LHF	1/4" MP LHF	--	20K psi (1379 bar)
21-013-002	SLIMLINE COUPLING (COUNTERBORE REMOVED FROM ONE END)	3/8" MP LHF	3/8" MP LHF	--	20K psi (1379 bar)
21-013-003	SLIMLINE COUPLING (COUNTERBORE REMOVED FROM ONE END)	9/16" MP LHF	9/16" MP LHF	0.750"	20K psi (1379 bar)
21-013-004	SLIMLINE COUPLING	3/4" MP LHF	3/4" MP LHF	--	20K psi (1379 bar)
21-013-005	SLIMLINE COUPLING	1" MP LHF	1" MP LHF	--	20K psi (1379 bar)
21-013-006	SLIMLINE COUPLING	3/8" MP LHF	1/4" MP LHF	0.468"	20K psi (1379 bar)
21-013-007	SLIMLINE COUPLING	9/16" MP LHF	1/4" MP LHF	--	20K psi (1379 bar)
21-013-008	SLIMLINE COUPLING	9/16" MP LHF	3/8" MP LHF	--	20K psi (1379 bar)
21-014-001	SLIMLINE COUPLING	1/4" MP LHF	1/4" MP RHF	--	20K psi (1379 bar)
21-014-002	SLIMLINE COUPLING	3/8" MP LHF	3/8" MP RHF	--	20K psi (1379 bar)
21-014-003	SLIMLINE COUPLING	9/16" MP LHF	9/16" MP RHF	0.750"	20K psi (1379 bar)
21-014-004	SLIMLINE COUPLING	3/4" MP LHF	3/4" MP LHF	--	20K psi (1379 bar)
21-014-005	SLIMLINE COUPLING	1" MP LHF	1" MP RHF	--	20K psi (1379 bar)
21-014-006	SLIMLINE COUPLING	9/16" MP LHF	1/4" MP RHF	--	20K psi (1379 bar)
21-014-007	SLIMLINE COUPLING	9/16" MP LHF	3/8" MP RHF	--	20K psi (1379 bar)
21-015-001	SLIMLINE COUPLING	1/4" MP RHF	1/4" MP RHF	--	20K psi (1379 bar)

SLIMLINE COUPLINGS*(Continued)*

PART NO.	SLIMLINE COUPLINGS	INLET	OUTLET	O.D.	MAX PRESSURE
21-015-002	SLIMLINE COUPLING	3/8" MP RHF	3/8" MP RHF	--	20K psi (1379 bar)
21-015-003	SLIMLINE COUPLING	9/16" MP RHF	9/16" MP RHF	--	20K psi (1379 bar)
21-015-004	SLIMLINE COUPLING	3/4" MP RHF	3/4" MP RHF	--	20K psi (1379 bar)
21-015-005	SLIMLINE COUPLING	1" MP RHF	1" MP RHF	1.375"	20K psi (1379 bar)
21-015-006	SLIMLINE COUPLING	3/8" MP RHF	1/4" MP RHF	--	20K psi (1379 bar)
21-015-007	SLIMLINE COUPLING	9/16" MP RHF	1/4" MP RHF	--	20K psi (1379 bar)
21-015-008	SLIMLINE COUPLING	9/16" MP RHF	3/8" MP RHF	--	20K psi (1379 bar)
22-001-001	SLIMLINE COUPLING	1/4" HP RHF	1/4" HP RHF	0.375"	40K psi (2758 bar)
22-001-002	SLIMLINE COUPLING	1/4" HP RHF	1/4" HP LHF	--	40K psi (2758 bar)
22-001-003	SLIMLINE COUPLING	1/4" HP LHF	1/4" HP LHF	--	40K psi (2758 bar)
22-001-004	SLIMLINE COUPLING (GDWJ TYPE: 77408084)	5/16" UH RHF	5/16" UH RHF	--	40K psi (2758 bar)
22-001-005	SLIMLINE COUPLING	3/8" UH/HP RHF	3/8" UH/HP RHF	--	40K psi (2758 bar)
22-001-006	SLIMLINE COUPLING	3/8" UH/HP RHF	3/8" HP LHF	--	40K psi (2758 bar)
22-001-007	SLIMLINE COUPLING (GDWJ TYPE: 77513122) (COUNTERBORE REMOVED FROM ONE END)	3/8" HP LHF	3/8" HP LHF	--	40K psi (2758 bar)
22-001-008	SLIMLINE COUPLING	7/16" UH RHF BUTTON	7/16" UH RHF BUTTON	--	40K psi (2758 bar)
22-001-009	SLIMLINE COUPLING	9/16" UH RHF BUTTON	1/4" HP RHF	--	40K psi (2758 bar)
22-001-010	SLIMLINE COUPLING	9/16" UH RHF BUTTON	5/16" UH RHF	--	40K psi (2758 bar)
22-001-011	SLIMLINE COUPLING (GDWJ TYPE: 77408060)	9/16" UH RHF BUTTON	3/8" UH/HP RHF	--	40K psi (2758 bar)
22-001-012	SLIMLINE COUPLING	9/16" UH RHF BUTTON	7/16" UH RHF BUTTON	--	40K psi (2758 bar)
22-001-013	STAINLESS STEEL SLIMLINE COUPLING	9/16" UH RHF BUTTON	9/16" UH RHF BUTTON	0.750"	40K psi (2758 bar)
22-001-014	SLIMLINE COUPLING	9/16" UH RHF BUTTON	9/16" UH LHF BUTTON	--	40K psi (2758 bar)
22-001-015	SLIMLINE COUPLING (AF 073-H9R-H9R-SL) (COUNTERBORE REMOVED FROM ONE END)	9/16" HP RHF	9/16" HP RHF	--	40K psi (2758 bar)
22-001-016	SLIMLINE COUPLING	9/16" HP RHF	9/16" HP LHF	--	40K psi (2758 bar)
22-001-017	SLIMLINE COUPLING	9/16" HP LHF	9/16" HP LHF	--	40K psi (2758 bar)
22-001-018	SLIMLINE COUPLING	3/4" HP RHF	3/4" HP RHF	--	40K psi (2758 bar)
22-001-019	SLIMLINE COUPLING	3/4" HP RHF	3/4" HP LHF	--	40K psi (2758 bar)
22-001-020	SLIMLINE COUPLING	3/4" HP LHF	3/4" HP LHF	--	40K psi (2758 bar)
22-001-021	SLIMLINE COUPLING	1" HP RHF	1" HP RHF	--	40K psi (2758 bar)
22-001-022	SLIMLINE COUPLING	1" HP LHF	1" HP RHF	--	40K psi (2758 bar)
22-001-023	SLIMLINE COUPLING	1" HP RHF	1" HP LHF	--	40K psi (2758 bar)
22-001-024	SLIMLINE COUPLING	1" HP LHF	1" HP LHF	--	40K psi (2758 bar)
22-001-025	SLIMLINE COUPLING	9/16" HP RHF	1/4" HP RHF	--	40K psi (2758 bar)
22-001-026	STAINLESS STEEL SLIMLINE COUPLING (COUNTERBORE ON 9/16" END)	9/16" HP RHF	3/8" HP RHF	--	40K psi (2758 bar)
22-001-027	SLIMLINE COUPLING	9/16" HP LHF	1/4" HP LHF	0.750"	40K psi (2758 bar)
22-001-028	SLIMLINE COUPLING	9/16" HP LHF	3/8" HP LHF	0.750"	40K psi (2758 bar)

AUTOCLAVE STYLE STRAIGHT COUPLERS

These Stainless Steel Autoclave Style Couplers are also available without gland nuts and collars.

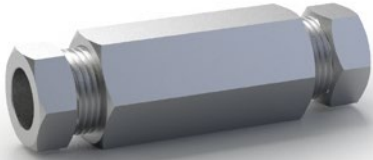

PART NO.	AUTOCLAVE STRAIGHT COUPLERS	INLET	OUTLET	MAX PRESSURE
21-012-001	COUPLER W/ GLAND NUTS & COLLARS	1/4" MP	--	20K psi (1379 bar)
21-012-002	COUPLER W/ GLAND NUTS & COLLARS	3/8" MP	--	20K psi (1379 bar)
21-012-003	COUPLER W/ GLAND NUTS & COLLARS	9/16" MP	--	20K psi (1379 bar)
21-012-004	COUPLER W/ GLAND NUTS & COLLARS	3/4" MP	--	20K psi (1379 bar)
21-012-005	COUPLER W/ GLAND NUTS & COLLARS	1" MP	--	20K psi (1379 bar)
21-012-006	COUPLER W/ GLAND NUTS & COLLARS	1/4" MP	3/8" MP	20K psi (1379 bar)
21-012-007	COUPLER W/ GLAND NUTS & COLLARS	1/4" MP	9/16" MP	20K psi (1379 bar)
21-012-008	COUPLER W/ GLAND NUTS & COLLARS (21F6M9M)	3/8" MP	9/16" MP	20K psi (1379 bar)
21-012-009	COUPLER W/ GLAND NUTS & COLLARS	9/16" MP	3/4" MP	20K psi (1379 bar)
21-012-010	COUPLER W/ GLAND NUTS & COLLARS	3/4" MP	1" MP	20K psi (1379 bar)

BSPP COUPLINGS

BSPP Couplings rated for 15K psi are primarily used on rotary lance machines when downgrading from 20K and 40K psi to 15K psi applications.

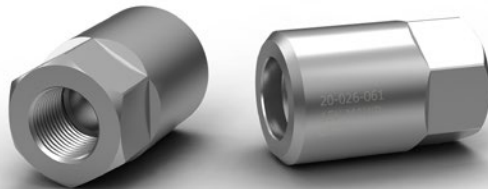

PART NO.	BSPP COUPLINGS	INLET	OUTLET	MAX PRESSURE
20-026-012	COPPER COATED COUPLING	1/8" BSPP	1/8" BSPP	15K psi (1034 bar)
20-026-013	COPPER COATED COUPLING	1/4" BSPP	1/4" BSPP	15K psi (1034 bar)
20-026-041	STAINLESS STEEL COUPLING	3/8" NPTF	1/2" BSPPF	15K psi (1034 bar)
20-026-046	STAINLESS STEEL COUPLING W/O GLAND NUT & COLLAR	1/4" BSPPF	3/8" MPF (9/16"-18)	15K psi (1034 bar)
20-026-057	COUPLING	1/2" BSPP	1/2" BSPP	15K psi (1034 bar)
20-026-061	STAINLESS STEEL HEAVY DUTY COUPLING W/ HEX	3/8" NPTF	3/8" BSPPF	15K psi (1034 bar)
20-026-064	STAINLESS STEEL COUPLING	1/4" BSPPF	1/4" HPF	15K psi (1034 bar)
20-026-070	STAINLESS STEEL COUPLING	3/8" BSPPF	3/8" BSPPF	15K psi (1034 bar)
20-026-071	STAINLESS STEEL COUPLING	3/8" NPTF	3/8" BSPPF	15K psi (1034 bar)
20-026-069	STAINLESS STEEL COUPLING	1/4" BSPPF	1/4" HPF	25K psi (1724 bar)

SCREW TYPE QUICK DISCONNECT COUPLINGS

Screw Type Quick Disconnect Hose Couplings are made from heat-treated stainless steel for high durability. Sizes available to suit most hoses, and all feature easy-grip texturing for ease of use.



PART NO.	SCREW TYPE QUICK DISCONNECT COUPLINGS	INLET	MAX PRESSURE
20-003-004	FEMALE SCREW TYPE COUPLING HALF ASSEMBLY	1" NPT	10K psi (690 bar)
20-003-003	FEMALE SCREW TYPE COUPLING HALF ASSEMBLY	3/4" NPT	12K psi (827 bar)
20-003-016	SCREW TYPE COUPLING ASSEMBLY	1" NPT	12K psi (827 bar)
20-003-018	MALE SCREW TYPE COUPLING HALF ASSEMBLY	1" NPT	12K psi (827 bar)
20-003-005	SCREW TYPE COUPLING ASSEMBLY	3/8" NPT	15K psi (1034 bar)
20-003-007	MALE SCREW TYPE COUPLING HALF ASSEMBLY	3/8" NPT	15K psi (1034 bar)
20-003-001	FEMALE SCREW TYPE COUPLING HALF ASSEMBLY	3/8" NPT	15K psi (1034 bar)
20-003-008	SCREW TYPE COUPLING ASSEMBLY (J/S TYPE: 50989)	1/2" NPT	15K psi (1034 bar)
20-003-010	STAINLESS STEEL MALE SCREW TYPE COUPLING HALF ASSEMBLY (GDWJ TYPE: 77516007)	1/2" NPT	15K psi (1034 bar)
20-003-002	FEMALE SCREW TYPE COUPLING HALF ASSEMBLY, INCLUDING NUT & RETAINING RING (GDWJ TYPE: 77516000)	1/2" NPT	15K psi (1034 bar)
20-003-012	SCREW TYPE COUPLING ASSEMBLY	3/4" NPT	15K psi (1034 bar)
20-003-014	MALE SCREW TYPE COUPLING HALF ASSEMBLY	3/4" NPT	15K psi (1034 bar)
21-025-001	SCREW TYPE COUPLING ASSEMBLY	9/16" MP	20K psi (1379 bar)
21-025-002	FEMALE SCREW TYPE COUPLING HALF ASSEMBLY	9/16" MP	20K psi (1379 bar)
21-025-003	MALE SCREW TYPE COUPLING HALF ASSEMBLY	9/16" MP	20K psi (1379 bar)
21-025-004	SCREW TYPE COUPLING NUT	9/16" MP	20K psi (1379 bar)
21-025-005	FEMALE SCREW TYPE COUPLING HALF ASSEMBLY	9/16" MP	20K psi (1379 bar)
21-025-006	SCREW TYPE COUPLING ASSEMBLY	3/4" MP	20K psi (1379 bar)
21-025-007	FEMALE SCREW TYPE COUPLING HALF ASSEMBLY	3/4" MP	20K psi (1379 bar)
21-025-008	MALE SCREW TYPE COUPLING HALF ASSEMBLY	3/4" MP	20K psi (1379 bar)
21-025-009	SCREW TYPE COUPLING NUT	3/4" MP	20K psi (1379 bar)
21-025-010	FEMALE SCREW TYPE COUPLING HALF ASSEMBLY	3/4" MP	20K psi (1379 bar)
21-025-011	SCREW TYPE COUPLING ASSEMBLY	3/4" MP	20K psi (1379 bar)
30-001-018	2-018 BUNA-N 90 DURO O-RING (GDWJ TYPE: 22-17046)	--	--
30-001-122	2-122 BUNA-N 90 DURO O-RING (J/S TYPE: 26776)	--	--
30-001-218	2-218 BUNA-N 90 DURO O-RING (GDWJ TYPE: 22-74207)	--	--
30-003-018	8-018 BUNA-N 90 DURO BACK-UP RING (GDWJ TYPE 22-17047)	--	--
30-003-122	8-122 BUNA-N 90 DURO BACK-UP RING	--	--
30-003-218	8-218 BUNA-N 90 DURO BACK-UP RING	--	--
30-008-010	3/4" DURO 90 ROD TYPE T-SEAL	--	--
30-008-012	7/8" DURA 90 ROD TYPE T-SEAL	--	--

AEROQUIP™ TYPE QUICK DISCONNECT COUPLINGS

Aeroquip™ Type Quick Disconnect Hose Couplings are also made from heat-treated stainless steel. Sizes available to suit most hoses, and all feature easy-grip texturing for ease of use.



PART NO.	AEROQUIP™ TYPE QUICK DISCONNECT COUPLINGS	INLET	MAX PRESSURE
20-003-030	AEROQUIP QUICK DISCONNECT COUPLING ASSEMBLY (FD-69) (GDWJ TYPE: 3477297)	3/8" NPTF	10K psi (690 bar)
20-003-031	AEROQUIP QUICK DISCONNECT MALE HALF COUPLING ASSEMBLY (GDWJ TYPE: 3477297001)	3/8" NPTF	10K psi (690 bar)
20-003-032	AEROQUIP QUICK DISCONNECT FEMALE HALF COUPLING ASSEMBLY (GDWJ TYPE: 3477297002)	3/8" NPTF	10K psi (690 bar)
20-003-033	AEROQUIP QUICK DISCONNECT COUPLING ASSEMBLY (FD-69) (NLB TYPE: NQC-22) (GDWJ TYPE: 3477295)	1/2" NPTF	10K psi (690 bar)
20-003-034	AEROQUIP QUICK DISCONNECT MALE HALF COUPLING ASSEMBLY (GDWJ TYPE: 3477295001)	1/2" NPTF	10K psi (690 bar)
20-003-035	AEROQUIP QUICK DISCONNECT FEMALE HALF COUPLING ASSEMBLY (GDWJ TYPE: 3477295002)	1/2" NPTF	10K psi (690 bar)
30-001-209	2-209 BUNA-N 90 DURO O-RING (F/ AEROQUIP QUICK DISCONNECT COUPLING)	--	--
30-003-209	8-209 BUNA-N 90 DURO BACK-UP RING (F/ AEROQUIP QUICK DISCONNECT COUPLING)	--	--

WAFER ELBOWS

Wafer Elbows are made from stainless steel and are heat treated. They are available in a variety of configurations including Crosses, Tees and Wyes (next page).



PART NO.	45° & 90° WAFER ELBOWS	INLET	MAX PRESSURE
20-004-018	45° WAFER ELBOW	1" NPT	12K psi (827 bar)
20-004-013	45° WAFER ELBOW	1/8" NPT	15K psi (1034 bar)
20-004-014	45° WAFER ELBOW	1/4" NPT	15K psi (1034 bar)
20-004-015	45° WAFER ELBOW	3/8" NPT	15K psi (1034 bar)
20-004-016	45° WAFER ELBOW	1/2" NPT	15K psi (1034 bar)
20-004-017	45° WAFER ELBOW	3/4" NPT	15K psi (1034 bar)
20-004-012	90° WAFER ELBOW	1" NPT	12K psi (827 bar)
20-004-007	90° WAFER ELBOW	1/8" NPT	15K psi (1034 bar)
20-004-008	90° WAFER ELBOW	1/4" NPT	15K psi (1034 bar)
20-004-009	90° WAFER ELBOW	3/8" NPT	15K psi (1034 bar)
20-004-010	90° WAFER ELBOW	1/2" NPT	15K psi (1034 bar)
20-004-011	90° WAFER ELBOW	3/4" NPT	15K psi (1034 bar)

WAFER CROSSES, TEES & WYES

These rugged Wafer Type Fittings are made from stainless steel and are heat treated.



PART NO.	WAFER CROSSES, TEES & WYES	INLET	OUTLET	MAX PRESSURE
20-004-024	WAFER CROSS	1" NPT	--	12K psi (827 bar)
20-004-019	WAFER CROSS	1/8" NPT	--	15K psi (1034 bar)
20-004-020	WAFER CROSS	1/4" NPT	--	15K psi (1034 bar)
20-004-021	WAFER CROSS	3/8" NPT	--	15K psi (1034 bar)
20-004-022	WAFER CROSS	1/2" NPT	--	15K psi (1034 bar)
20-004-023	WAFER CROSS	3/4" NPT	--	15K psi (1034 bar)
20-004-006	WAFER TEE	1" NPT	--	12K psi (827 bar)
20-004-031	WAFER REDUCING TEE	3/4" NPT	1" NPT	12K psi (827 bar)
20-004-001	WAFER TEE	1/8" NPT	--	15K psi (1034 bar)
20-004-002	WAFER TEE	1/4" NPT	--	15K psi (1034 bar)
20-004-003	WAFER TEE	3/8" NPT	--	15K psi (1034 bar)
20-004-004	WAFER TEE	1/2" NPT	--	15K psi (1034 bar)
20-004-005	WAFER TEE	3/4" NPT	--	15K psi (1034 bar)
20-004-032	WAFER REDUCING TEE	1/4" NPT	3/8" NPT	15K psi (1034 bar)
20-004-033	WAFER REDUCING TEE	1/4" NPT	1/2" NPT	15K psi (1034 bar)
20-004-030	WAFER WYE	1" NPT	--	12K psi (827 bar)
20-004-025	WAFER WYE	1/8" NPT	--	15K psi (1034 bar)
20-004-026	WAFER WYE	1/4" NPT	--	15K psi (1034 bar)
20-004-027	WAFER WYE	3/8" NPT	--	15K psi (1034 bar)
20-004-028	WAFER WYE	1/2" NPT	--	15K psi (1034 bar)
20-004-029	WAFER WYE	3/4" NPT	--	15K psi (1034 bar)

HEX NIPPLES

In both straight and reducing varieties specifically for water blasting service, these Hex Nipples are made from heavy duty stainless steel because of its reliability and durability.



PART NO.	HEX NIPPLES	INLET	OUTLET	MAX PRESSURE
20-011-013	HEX NIPPLE	1" NPTM	1" NPTM	12K psi (827 bar)
20-011-014	HEX NIPPLE	1" NPTM	1/2" NPTM	12K psi (827 bar)
20-011-015	HEX NIPPLE	1" NPTM	3/4" NPTM	12K psi (827 bar)
20-011-001	HEX NIPPLE	1/16" NPTM	1/16" NPTM	15K psi (1034 bar)
20-011-002	HEX NIPPLE	1/8" NPTM	1/8" NPTM	15K psi (1034 bar)
20-011-003	HEX NIPPLE	1/8" NPTM	1/16" NPTM	15K psi (1034 bar)
20-011-004	HEX NIPPLE	1/4" NPTM	1/4" NPTM	15K psi (1034 bar)
20-011-005	HEX NIPPLE	1/4" NPTM	1/8" NPTM	15K psi (1034 bar)
20-011-006	HEX NIPPLE	3/8" NPTM	3/8" NPTM	15K psi (1034 bar)
20-011-007	HEX NIPPLE	3/8" NPTM	1/4" NPTM	15K psi (1034 bar)
20-011-008	HEX NIPPLE (GDWJ TYPE: 3432509) (J/S TYPE: 50488)	1/2" NPTM	1/2" NPTM	15K psi (1034 bar)
20-011-009	HEX NIPPLE	1/2" NPTM	1/4" NPTM	15K psi (1034 bar)
20-011-010	HEX NIPPLE	1/2" NPTM	3/8" NPTM	15K psi (1034 bar)
20-011-011	HEX NIPPLE	3/4" NPTM	3/4" NPTM	15K psi (1034 bar)
20-011-012	HEX NIPPLE (J/S TYPE: 51702)	3/4" NPTM	1/2" NPTM	15K psi (1034 bar)
20-011-016	HEX NIPPLE	3/4" NPTM	3/8" NPTM	15K psi (1034 bar)

WINGED TYPE HAMMER UNIONS

Advanced Pressure Systems offers Winged Type Hammer Unions with large screw threads and a hub that can be “knocked off” with a hammer for quick disconnection of hoses. Connections are available to suit most hoses. NPT connections feature heavy duty O-Rings.

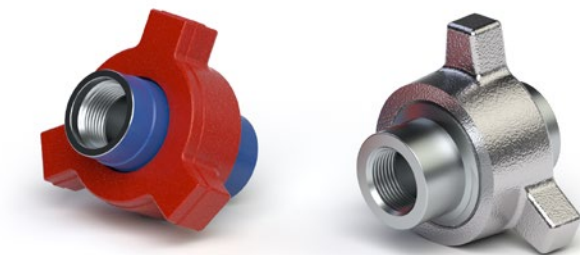

PART NO.	WINGED TYPE HAMMER UNIONS	INLET	MAX PRESSURE
20-050-001	ARMSTRONG-WEATHERLY WING TYPE HAMMER UNION	1/2" NPT	10K psi (690 bar)
20-050-002	ARMSTRONG-WEATHERLY WING TYPE HAMMER UNION	3/4" NPT	10K psi (690 bar)
20-050-003	ARMSTRONG-WEATHERLY WING TYPE HAMMER UNION	1" NPT	10K psi (690 bar)
20-050-100	WING TYPE KEMPER HAMMER UNION ASSEMBLY	--	10K psi (690 bar)
20-050-004	1" ARMSTRONG-WEATHERLY HAMMER UNION O-RING	--	--
20-050-005	3/4" ARMSTRONG-WEATHERLY HAMMER UNION O-RING	--	--
20-050-006	1/2" ARMSTRONG-WEATHERLY HAMMER UNION O-RING	--	--
20-050-101	1" WING TYPE KEMPER HAMMER UNION SEAL	--	--

DUAL LANCE MANIFOLDS

Compact Stainless Steel Dual Lance Manifolds allow the user to run two rigid lances from a single control valve correctly.

When ordering, please specify inlet and outlet sizes.



PART NO.	DUAL LANCE MANIFOLDS	INLET	OUTLET	MAX PRESSURE
20-025-001	DUAL LANCE MANIFOLD	1/2" NPTF	2-1/16" NPTF	15K psi (1034 bar)
20-025-002	DUAL LANCE MANIFOLD	1/2" NPTF	2-1/8" NPTF	15K psi (1034 bar)
20-025-003	DUAL LANCE MANIFOLD	1/2" NPTF	2-1/4" NPTF	15K psi (1034 bar)
20-025-004	DUAL LANCE MANIFOLD	1/2" NPTF	2-1/2" NPTF	15K psi (1034 bar)

RIGID LANCE HOLDERS

The threaded end of a rigid lance where it connects directly to a manifold is its weakest point. A break at this threaded connection renders an otherwise good lance unstable.

Our Rigid Lance Holders provide full support to the lance at a point well in front of the thread. The lance holder is designed to be the best available on the market. It uses a collet and lock nut of the same design as used for a machine shop lathe, which provides a vise-like grip on the lance, completely relieving stress on the thread.

Installation or removal of the lance is very easily accomplished. Simply slide the End Cap, Collet and Lance Holder Support Tube on to the lance in that order and screw the lance in to the Lance Holder Body. The Lance Holder Tube is then screwed in to the Body, and the Collet is secured in to the Lance Holder Tube by the End Cap. The lance will then be fully supported.



PART NO.	RIGID LANCE HOLDERS	INLET	OUTLET	MAX PRESSURE
20-002-001	RIGID LANCE HOLDER ASSEMBLY	1/2" NPTM	1/16" NPTF	15K psi (1034 bar)
20-002-002	RIGID LANCE HOLDER ASSEMBLY	1/2" NPTM	1/8" NPTF	15K psi (1034 bar)
20-002-003	RIGID LANCE HOLDER ASSEMBLY	1/2" NPTM	1/4" NPTF	15K psi (1034 bar)
21-030-001	RIGID LANCE HOLDER ASSEMBLY	9/16" MPF	1/4"-28 RHF	20K psi (1379 bar)
21-030-002	RIGID LANCE HOLDER ASSEMBLY	9/16" MPF	3/8"-24 RHF	20K psi (1379 bar)
21-030-003	RIGID LANCE HOLDER ASSEMBLY	9/16" MPF	9/16"-18 RHF	20K psi (1379 bar)
21-030-004	RIGID LANCE HOLDER ASSEMBLY	9/16" MPF	1/4"-28 LHF	20K psi (1379 bar)
21-030-005	RIGID LANCE HOLDER ASSEMBLY	9/16" MPF	3/8"-24 LHF	20K psi (1379 bar)
21-030-006	RIGID LANCE HOLDER ASSEMBLY	9/16" MPF	9/16"-18 LHF	20K psi (1379 bar)

PIPE & TUBE NIPPLES

We offer a growing line of quality Pipe Nipples, available in 304 stainless steel. Non-standard-length nipples are available upon request. Please specify length and thread size when ordering.



PART NO.	PIPE & TUBE NIPPLES	INLET	LENGTH	MAX PRESSURE
20-014-012	STAINLESS STEEL PIPE NIPPLE	3/4" NPT	12"	10K psi (690 bar)
20-014-018	STAINLESS STEEL PIPE NIPPLE	3/4" NPT	18"	10K psi (690 bar)
20-014-024	STAINLESS STEEL PIPE NIPPLE	3/4" NPT	24"	10K psi (690 bar)
20-014-036	STAINLESS STEEL PIPE NIPPLE	3/4" NPT	36"	10K psi (690 bar)
20-014-048	STAINLESS STEEL PIPE NIPPLE	3/4" NPT	48"	10K psi (690 bar)
20-015-012	STAINLESS STEEL PIPE NIPPLE	1" NPT	12"	10K psi (690 bar)
20-015-018	STAINLESS STEEL PIPE NIPPLE	1" NPT	18"	10K psi (690 bar)
20-015-024	STAINLESS STEEL PIPE NIPPLE	1" NPT	24"	10K psi (690 bar)
20-015-036	STAINLESS STEEL PIPE NIPPLE	1" NPT	36"	10K psi (690 bar)
20-015-048	STAINLESS STEEL PIPE NIPPLE	1" NPT	48"	10K psi (690 bar)
20-006-012	STAINLESS STEEL PIPE NIPPLE	1/16" NPT	12"	15K psi (1034 bar)
20-006-018	STAINLESS STEEL PIPE NIPPLE	1/16" NPT	18"	15K psi (1034 bar)
20-006-024	STAINLESS STEEL PIPE NIPPLE	1/16" NPT	24"	15K psi (1034 bar)
20-006-036	STAINLESS STEEL PIPE NIPPLE	1/16" NPT	36"	15K psi (1034 bar)
20-006-048	STAINLESS STEEL PIPE NIPPLE	1/16" NPT	48"	15K psi (1034 bar)
20-007-012	STAINLESS STEEL PIPE NIPPLE	1/8" NPT	12"	15K psi (1034 bar)
20-007-018	STAINLESS STEEL PIPE NIPPLE	1/8" NPT	18"	15K psi (1034 bar)
20-007-024	STAINLESS STEEL PIPE NIPPLE	1/8" NPT	24"	15K psi (1034 bar)
20-007-036	STAINLESS STEEL PIPE NIPPLE	1/8" NPT	36"	15K psi (1034 bar)
20-007-048	STAINLESS STEEL PIPE NIPPLE	1/8" NPT	48"	15K psi (1034 bar)
20-008-012	STAINLESS STEEL PIPE NIPPLE	1/4" NPT	12"	15K psi (1034 bar)
20-008-018	STAINLESS STEEL PIPE NIPPLE	1/4" NPT	18"	15K psi (1034 bar)
20-008-024	STAINLESS STEEL PIPE NIPPLE	1/4" NPT	24"	15K psi (1034 bar)
20-008-036	STAINLESS STEEL PIPE NIPPLE	1/4" NPT	36"	15K psi (1034 bar)
20-008-048	STAINLESS STEEL PIPE NIPPLE	1/4" NPT	48"	15K psi (1034 bar)
20-012-012	STAINLESS STEEL PIPE NIPPLE	3/8" NPT	12"	15K psi (1034 bar)
20-012-018	STAINLESS STEEL PIPE NIPPLE	3/8" NPT	18"	15K psi (1034 bar)
20-012-024	STAINLESS STEEL PIPE NIPPLE	3/8" NPT	24"	15K psi (1034 bar)
20-012-036	STAINLESS STEEL PIPE NIPPLE	3/8" NPT	36"	15K psi (1034 bar)

PIPE & TUBE NIPPLES

(Continued)

PART NO.	PIPE & TUBE NIPPLES	INLET	LENGTH	MAX PRESSURE
20-012-048	STAINLESS STEEL PIPE NIPPLE	3/8" NPT	48"	15K psi (1034 bar)
20-013-012	STAINLESS STEEL PIPE NIPPLE	1/2" NPT	12"	15K psi (1034 bar)
20-013-018	STAINLESS STEEL PIPE NIPPLE	1/2" NPT	18"	15K psi (1034 bar)
20-013-024	STAINLESS STEEL PIPE NIPPLE	1/2" NPT	24"	15K psi (1034 bar)
20-013-036	STAINLESS STEEL PIPE NIPPLE	1/2" NPT	36"	15K psi (1034 bar)
20-013-048	STAINLESS STEEL PIPE NIPPLE	1/2" NPT	48"	15K psi (1034 bar)
20-107-010	STAINLESS STEEL PIPE NIPPLE	1/8"-28 BSPP	10"	15K psi (1034 bar)
20-107-020	STAINLESS STEEL PIPE NIPPLE	1/8"-28 BSPP	20"	15K psi (1034 bar)
20-107-048	STAINLESS STEEL PIPE NIPPLE	1/8"-28 BSPP	48"	15K psi (1034 bar)
20-108-010	STAINLESS STEEL PIPE NIPPLE	1/4"-19 BSPP	10"	15K psi (1034 bar)
20-108-020	STAINLESS STEEL PIPE NIPPLE	1/4"-19 BSPP	20"	15K psi (1034 bar)
20-108-040	STAINLESS STEEL PIPE NIPPLE	1/4"-19 BSPP	40"	15K psi (1034 bar)
20-108-048	STAINLESS STEEL PIPE NIPPLE	1/4"-19 BSPP	48"	15K psi (1034 bar)
20-113-024	STAINLESS STEEL PIPE NIPPLE	1/2" BSPP	24"	15K psi (1034 bar)
20-113-060	STAINLESS STEEL PIPE NIPPLE	1/2" BSPP	60"	15K psi (1034 bar)
20-213-048	STAINLESS STEEL PIPE NIPPLE	1/2" BSPP x 1/2" NPT	48"	15K psi (1034 bar)
21-020-003	STAINLESS STEEL TUBE NIPPLE	1/4" MP LH	3"	20K psi (1379 bar)
21-020-006	STAINLESS STEEL TUBE NIPPLE	1/4" MP LH	6"	20K psi (1379 bar)
21-020-008	STAINLESS STEEL TUBE NIPPLE	1/4" MP LH	8"	20K psi (1379 bar)
21-020-010	STAINLESS STEEL TUBE NIPPLE	1/4" MP LH	10"	20K psi (1379 bar)
21-020-012	STAINLESS STEEL TUBE NIPPLE	1/4" MP LH	12"	20K psi (1379 bar)
21-020-024	STAINLESS STEEL TUBE NIPPLE	1/4" MP LH	24"	20K psi (1379 bar)
21-020-036	STAINLESS STEEL TUBE NIPPLE	1/4" MP LH	36"	20K psi (1379 bar)
21-020-048	STAINLESS STEEL TUBE NIPPLE	1/4" MP LH	48"	20K psi (1379 bar)
21-021-003	STAINLESS STEEL TUBE NIPPLE	3/8" MP LH	3"	20K psi (1379 bar)
21-021-006	STAINLESS STEEL TUBE NIPPLE	3/8" MP LH	6"	20K psi (1379 bar)
21-021-008	STAINLESS STEEL TUBE NIPPLE	3/8" MP LH	8"	20K psi (1379 bar)
21-021-010	STAINLESS STEEL TUBE NIPPLE	3/8" MP LH	10"	20K psi (1379 bar)
21-021-012	STAINLESS STEEL TUBE NIPPLE	3/8" MP LH	12"	20K psi (1379 bar)
21-021-024	STAINLESS STEEL TUBE NIPPLE	3/8" MP LH	24"	20K psi (1379 bar)
21-021-036	STAINLESS STEEL TUBE NIPPLE	3/8" MP LH	36"	20K psi (1379 bar)
21-021-048	STAINLESS STEEL TUBE NIPPLE	3/8" MP LH	48"	20K psi (1379 bar)
21-022-003	STAINLESS STEEL TUBE NIPPLE	9/16" MP LH	3"	20K psi (1379 bar)
21-022-006	STAINLESS STEEL TUBE NIPPLE	9/16" MP LH	6"	20K psi (1379 bar)
21-022-008	STAINLESS STEEL TUBE NIPPLE	9/16" MP LH	8"	20K psi (1379 bar)
21-022-010	STAINLESS STEEL TUBE NIPPLE	9/16" MP LH	10"	20K psi (1379 bar)
21-022-012	STAINLESS STEEL TUBE NIPPLE	9/16" MP LH	12"	20K psi (1379 bar)
21-022-024	STAINLESS STEEL TUBE NIPPLE	9/16" MP LH	24"	20K psi (1379 bar)
21-022-036	STAINLESS STEEL TUBE NIPPLE	9/16" MP LH	36"	20K psi (1379 bar)
21-022-048	STAINLESS STEEL TUBE NIPPLE (GDWJ TYPE: 77513056)	9/16" MP LH	48"	20K psi (1379 bar)
21-022-060	STAINLESS STEEL TUBE NIPPLE	9/16" MP LH	60"	20K psi (1379 bar)
21-023-006	STAINLESS STEEL TUBE NIPPLE	3/4" MP LH	6"	20K psi (1379 bar)

PIPE & TUBE NIPPLES

(Continued)

PART NO.	PIPE & TUBE NIPPLES	INLET	LENGTH	MAX PRESSURE
20-023-008	STAINLESS STEEL TUBE NIPPLE	3/4" MP LH	8"	20K psi (1379 bar)
21-023-010	STAINLESS STEEL TUBE NIPPLE	3/4" MP LH	10"	20K psi (1379 bar)
21-023-012	STAINLESS STEEL TUBE NIPPLE	3/4" MP LH	12"	20K psi (1379 bar)
21-023-048	STAINLESS STEEL TUBE NIPPLE	3/4" MP LH	48"	20K psi (1379 bar)
21-024-006	STAINLESS STEEL TUBE NIPPLE	1" MP LH	6"	20K psi (1379 bar)
21-024-008	STAINLESS STEEL TUBE NIPPLE	1" MP LH	8"	20K psi (1379 bar)
21-024-010	STAINLESS STEEL TUBE NIPPLE	1" MP LH	10"	20K psi (1379 bar)
21-024-012	STAINLESS STEEL TUBE NIPPLE	1" MP LH	12"	20K psi (1379 bar)
21-024-024	STAINLESS STEEL TUBE NIPPLE	1" MP LH	24"	20K psi (1379 bar)
21-024-036	STAINLESS STEEL TUBE NIPPLE	1" MP LH	36"	20K psi (1379 bar)
21-024-048	STAINLESS STEEL TUBE NIPPLE	1" MP LH	48"	20K psi (1379 bar)
22-616-003	TUBE NIPPLE (THIS LENGTH WILL NOT WORK W/ GLAND NUTS @ COLLARS)	9/16" HP LH	3"	40K psi (2758 bar)
22-616-004	TUBE NIPPLE	9/16" HP LH	4"	40K psi (2758 bar)
22-616-006	TUBE NIPPLE	9/16" HP LH	6"	40K psi (2758 bar)
22-616-008	TUBE NIPPLE	9/16" HP LH	8"	40K psi (2758 bar)
22-616-012	TUBE NIPPLE	9/16" HP LH	12"	40K psi (2758 bar)
22-616-018	TUBE NIPPLE	9/16" HP LH	18"	40K psi (2758 bar)
22-616-024	TUBE NIPPLE	9/16" HP LH	24"	40K psi (2758 bar)
22-616-036	TUBE NIPPLE	9/16" HP LH	36"	40K psi (2758 bar)
22-616-048	TUBE NIPPLE	9/16" HP LH	48"	40K psi (2758 bar)
22-014-003	STAINLESS STEEL TUBE NIPPLE	1/4" HP LH	3"	60K psi (4137 bar)
22-015-004	STAINLESS STEEL TUBE NIPPLE	3/8" HP LH	4"	60K psi (4137 bar)
22-016-006	TUBE NIPPLE	9/16" HP LH	6"	60K psi (4137 bar)
22-114-	XXX	--	--	60K psi (4137 bar)
22-115-	XXX	--	--	60K psi (4137 bar)
22-116-	XXX	--	--	60K psi (4137 bar)
22-117-	XXX	--	--	60K psi (4137 bar)

FLEX LANCE SAFETY GRIPS

The Flex Lance Safety Grip is designed to minimize the risk of injury to flex lance operators caused by a live nozzle exiting the tube unexpectedly. The comfortably contoured handle makes it easy to hold the safety grip against the tube sheet, allowing retraction of an active nozzle in to a stainless steel sleeve, where the force of the jets is dissipated.



PART NO.	FLEX LANCE SAFETY GRIPS
35-009-000	SMALL FLEX LANCE SAFETY GUARD ASSEMBLY W/ 3 STOPS (0.323" / 0.442" / 0.510" F/ PARKER LANCES)
35-009-001	SMALL FLEX LANCE SAFETY GUARD HANDLE
35-009-002	0.323" FLEX LANCE SAFETY GUARD LANCE STOP (2004 & 3/4 LANCE) (GDWJ TYPE: 77209002)
35-009-003	0.390" FLEX LANCE SAFETY GUARD LANCE STOP (5/2 SPIR STAR) 3/6
35-009-004	0.442" FLEX LANCE SAFETY GUARD LANCE STOP (2005/4004 LANCE)
35-009-005	0.510" FLEX LANCE SAFETY GUARD LANCE STOP (2006 LANCE)
35-009-006	0.725" FLEX LANCE SAFETY GUARD LANCE STOP (2108 LANCE, 6/6H LANCE)
35-009-007	SMALL FLEX LANCE SAFETY GRIP DIFFUSER
35-009-008	LARGE FLEX LANCE SAFETY GRIP DIFFUSER
35-009-009	SMALL STAINLESS STEEL FLEX LANCE SAFETY GUARD HANDLE
35-009-010	0.290" FLEX LANCE SAFETY GUARD LANCE STOP (3/2 LANCE)
35-009-011	0.530" FLEX LANCE SAFETY GUARD LANCE STOP (6005 LANCE)
35-009-012	0.570" FLEX LANCE SAFETY GUARD LANCE STOP (1/4" NPT & 9/16" RIGID LANCE SIZE & 8/2 SPIR STAR)
35-009-013	0.468" FLEX LANCE SAFETY GUARD LANCE STOP (4005 LANCE)
35-009-014	0.870" FLEX LANCE SAFETY GUARD LANCE STOP

40K psi ARTICULATED FLEX LANCE SAFETY STOP

Assembly No. 36-015-089

The Articulated Flex Lance Safety Stop takes the Hand-Held Flex Lance Safety Grip to the next level. This versatile lance stop/anti-withdrawal device attaches easily to the tube sheet for safer pipe cleaning operations. It features adaptability to vertical or horizontal applications, and its wide range of expansion accommodates any size of tube sheet. Construction is galvanized steel with aluminum handles and includes a Lexan® splash guard.

The stops for six sizes of lances are provided by a quick-change insert, which is built in to the design, eliminating the problem of lost lance stops and makes changing to a different diameter quick and easy.

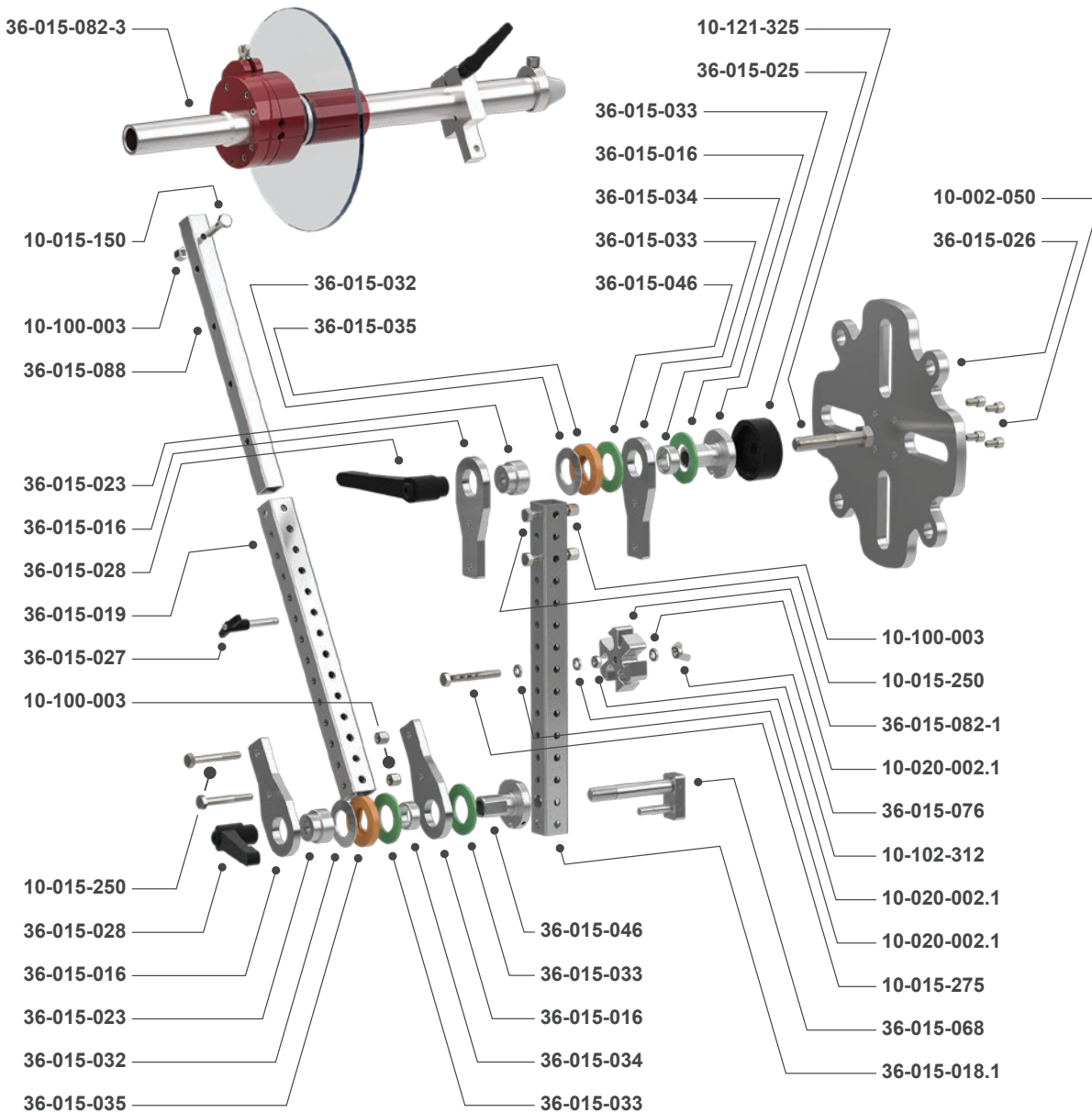

40K psi ARTICULATED FLEX LANCE SAFETY STOP

Assembly No. 36-015-089



PART NO.	BILL OF MATERIALS (Assembly No. 36-015-089)	QUANTITY
10-002-050	5/16"-18 X 1/2" LONG STAINLESS STEEL SHCS SCREW	4
10-015-150	5/16"-18 X 1-1/2" STAINLESS STEEL HEX HEAD BOLT	1
10-015-250	5/16"-18 X 2-1/2" STAINLESS STEEL HEX HEAD BOLT	4
10-020-002	5/16" STAINLESS STEEL LOCK WASHER	3
10-060-275	5/16"-18 X 2-3/4" LONG STAINLESS STEEL (FULL THREAD) TAP BOLT	1
10-100-003	5/16"-18 STAINLESS STEEL NYLON LOCK NUT	5
10-100-006	5/16"-18 316 STAINLESS STEEL JAM NUT	1
10-121-325	5/8"-11 X 3-1/4" C/S ZINC PLATED (GRADE 8) HEX HEAD BOLT	1
36-015-016	AWD PIVOT MOUNT PLATE (VL 113)	4
36-015-018.1	TELESPAR ARM ONE F/ WELDMENT ASSEMBLY (VL 115.1)	1
36-015-019	TELESPAR ARM TWO (VL 120)	1
36-015-023	TORQUE LIMITER SPACER (VL 135)	2
36-015-025	DALTON CLUTCH MOUNTING ADAPTER F/ MAIN PLATE	1
36-015-026	CHICKEN WING ADAPTER MOUNTING PLATE	1
36-015-027	5/16" X 1-1/2" LONG QUICK RELEASE PIN (VL 228)	1
36-015-028	5/8"-11 UNC THREADED ADJUSTABLE HANDLE NUT (VL 229)	2
36-015-032	TORQUE LIMITER BELLVILLE SPRING WASHER	2
36-015-033	TORQUE LIMITER FIBER WASHER	4
36-015-034	TORQUE LIMITER BEARING	2
36-015-035	ORANGE TORQUE LIMITER SPACER	5
36-015-046	AWD MODIFIED TORQUE LIMITER	2
36-015-068	PIVOT PIN & LOCKING PLATE ASSEMBLY	1
36-015-076	5/16"-18 STAINLESS STEEL WING NUT	1
36-015-082-3	VARIABLE LANCE STOP ASSEMBLY F/ CHICKEN WING (NEW)	1
36-015-088	TELESPAR EXTENSION ARM (NEW)	1

40K psi VARIABLE LANCE STOP ASSEMBLY

Assembly No. 36-015-082-3

The Variable Lance Stop Assembly attaches to the end of the arm of the Flex Lance Safety Device, commonly referred to as a Chicken Wing. It provides slotted inserts that can prevent the withdrawal of a flex lance from a tube sheet while under pressure. Two inserts are included in the assembly to cover six diameters for both Parker and Spir Star lances.

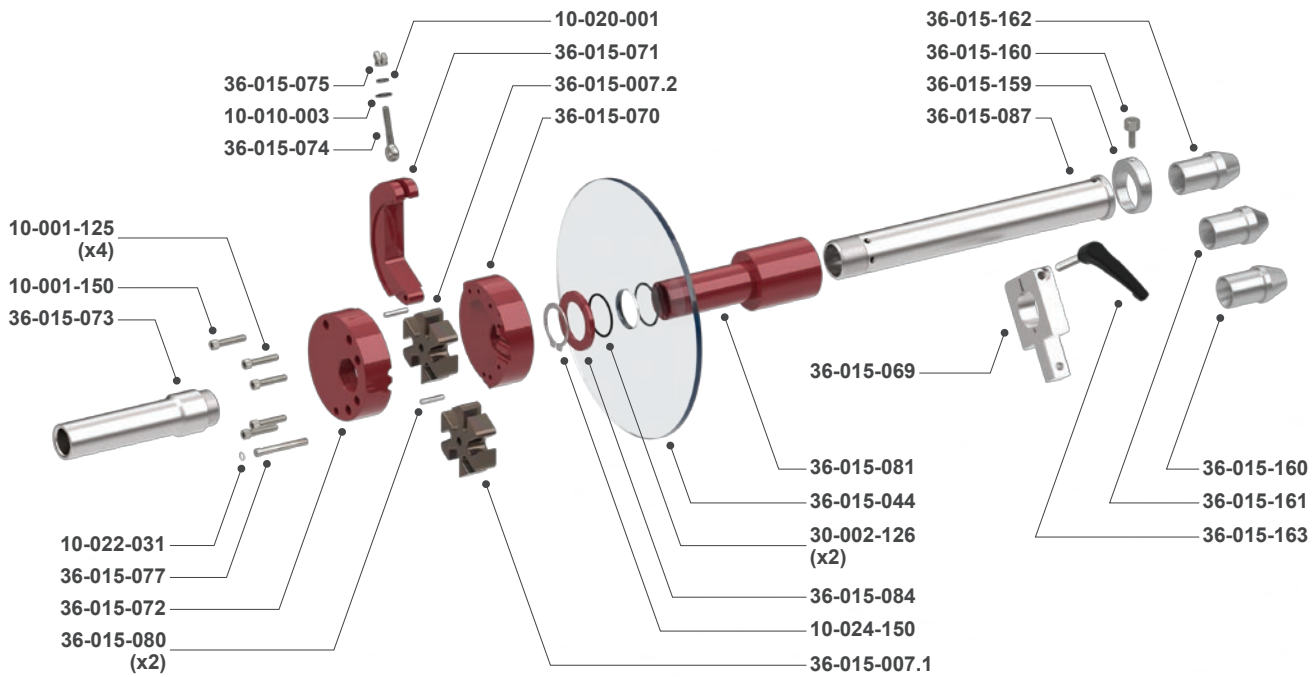

PART NO.	BILL OF MATERIALS (Assembly No. 36-015-082-3)	QUANTITY
10-001-125	1/4"-20 X 1-1/4" LONG STAINLESS STEEL SHCS SCREW (MIN YIELD 70K)	4
10-001-150	1/4"-20 X 1-1/2" LONG STAINLESS STEEL SHCS SCREW (MIN YIELD 70K)	1
10-010-003	1/4" FLAT STAINLESS STEEL WASHER	1
10-020-001	1/4" STAINLESS STEEL LOCK WASHER	1
10-022-031	TRUARC N5000-31 SS (INTERNAL) RETAINING RING	1
10-024-150	EXTERNAL STAINLESS STEEL RETAINING RING (5100-150)	1
30-002-126	2-126 BUNA-N 70 DURO O-RING	2
36-015-007.1	STAINLESS STEEL PARKER MULTIPLE LANCE STOP INSERT	1
36-015-007.2	SPIR STAR MULTIPLE LANCE STOP INSERT	1
36-015-031	5/16"-18 X 1.96" LONG THREAD ADJUSTABLE HANDLE (HRS 530)	1
36-015-044	1.500" SIZE SPLASH SHIELD	1
36-015-069	CHICKEN WING CLAMP (NEW STYLE)	1
36-015-070	LANCE BODY STOP (PART 1)	1
36-015-071	LANCE STOP HOLDER LATCH	1
36-015-072	LANCE BODY STOP (PART 2)	1

40K psi VARIABLE LANCE STOP ASSEMBLY

Assembly No. 36-015-082-3

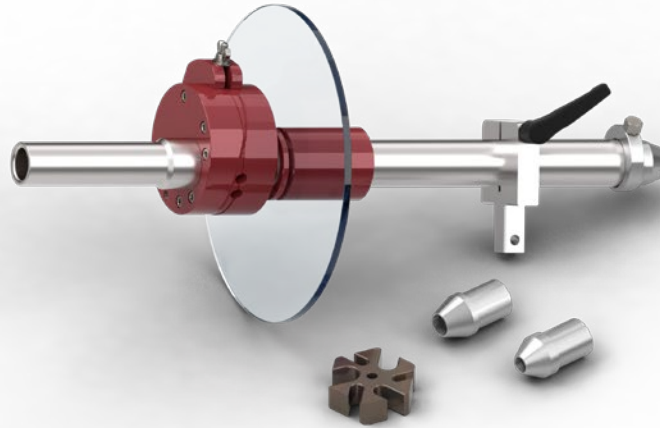

PART NO.	BILL OF MATERIALS (Assembly No. 36-015-082-3... Continued)	QUANTITY
36-015-073	LANCE GUIDE TUBE	1
36-015-074	1/4"-20 STAINLESS STEEL LATCH EYE BOLT	1
36-015-075	1/4"-20 STAINLESS STEEL WING NUT	1
36-015-077	RETAINER LATCH PIVOT PIN	1
36-015-080	3/16" DIAMETER X 1" LONG STAINLESS STEEL DOWEL PIN	2
36-015-081	EXTENSION TUBE HOLDER	1
36-015-084	SPLASH SHIELD RETAINING RING	1
36-015-087	1-1/2" X 12" STAINLESS STEEL EXTENSION TUBE ASSEMBLY	1
36-015-159	ECCENTRIC CHICKEN WING FLEX LANCE RETAINING RING	1
36-015-160	CHICKEN WING HEX HEAD THUMB SCREW	1
36-015-161	CHICKEN WING FLEX LANCE GUIDE BUSHING (0.625" I.D.)	1
36-015-162	CHICKEN WING FLEX LANCE GUIDE BUSHING (0.750" I.D.)	1
36-015-163	CHICKEN WING FLEX LANCE GUIDE BUSHING (0.437" I.D.)	1

15K psi AIR DIVERTER VALVE w/o BASE PLATE

Assembly No. 61-001-006

An Air Operated Dump Valve allows an operator to remotely control pressure in cleaning applications from 15K psi. When air is sent to the cylinder, the valve closes and allows the system to build pressure. The valve opens when the air is exhausted, reducing system pressure to near atmospheric.

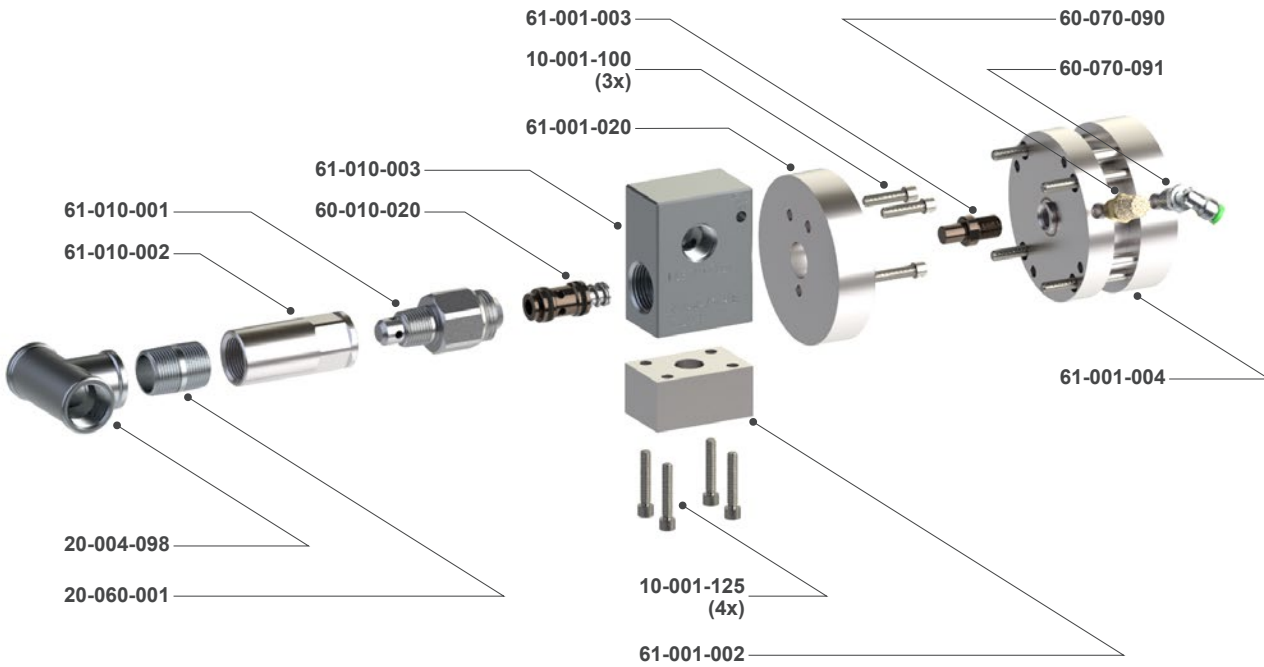

PART NO.	BILL OF MATERIALS (Assembly No. 61-001-006)	QUANTITY
10-001-100	1/4"-20 X 1" LONG STAINLESS STEEL SHCS SCREW (MIN YIELD 70K)	3
10-001-125	1/4"-20 X 1-1/4" LONG STAINLESS STEEL SHCS SCREW (MIN YIELD 70K)	4
20-004-098	3/4" NPT 316 STAINLESS STEEL THREADED TEE (150# CLASS)	1
20-060-001	3/4" NPT 316 SCH. 40 CLOSE NIPPLE (150 PSI)	1
60-010-020	15K HAND/FOOT GUN CARTRIDGE ASSEMBLY (J/S TYPE: 50902)	1
60-070-090	1/4" NPTM BRONZE SINTERRED MUFFLER	1
60-070-091	1/4" NPTM X 1/4" PARKER PUSH-LOK 90° SWIVEL ELBOW (300 MAX PSI)	1
61-001-002	15K AIR ACTUATOR RISER BLOCK	1
61-001-003	15/20K AIR ACTUATOR VALVE PLUNGER	1
61-001-004	15/20K BIMBA AIR ACTUATED CYLINDER	1
61-001-020	20K AIR ACTUATOR FOOT GUN PLATE	1
61-010-001	15K FOOT GUN DUMP ADAPTER	1
61-010-002	FOOT GUN DUMP TUBE	1
61-010-003	15K FOOT GUN BLOCK	1

15K psi AIR DIVERTER VALVE w/o BASE PLATE

Assembly No. 61-001-006

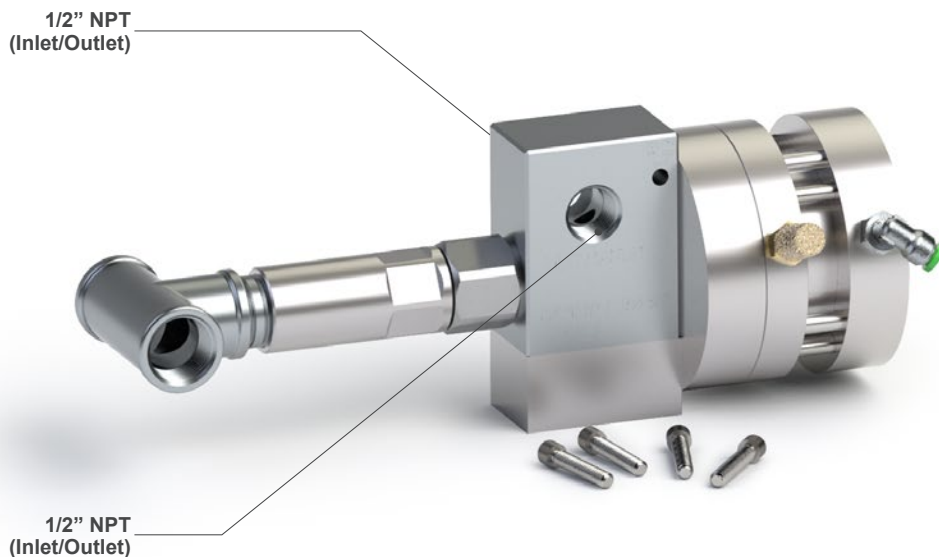

Paired for 15K psi Air Divider Valve w/o Base Plate...



20-003-008
 1/2" NPT SCREW TYPE COUPLING ASSEMBLY (15K MAWP)
 (J/S TYPE: 50989)



20-011-008
 1/2" NPTM X 1/2" NPTM HEX NIPPLE (15K MAWP)
 (GDWJ TYPE: 3432509) (J/S TYPE: 50488)



43-004-050
 1/2" NPT B/E X 50' 15K RUBBER WATERBLAST HOSE (CERTIFIED & TESTED) (GDWJ TYPE: 6122054050) (J/S TYPE: 52241-0500505)

XX-XXX-XXX
 XXXXX

20K psi AIR DIVERTER VALVE w/o RISER & BASE PLATE

Assembly No. 61-020-020.1

Air Operated Diverter Valves provide much improved operator safety by allowing control of flow and pressure to be carried out remotely. When air is sent to the cylinder, the valve closes and allows the system to build pressure. The valve opens when the air is exhausted, reducing system pressure to near atmospheric.

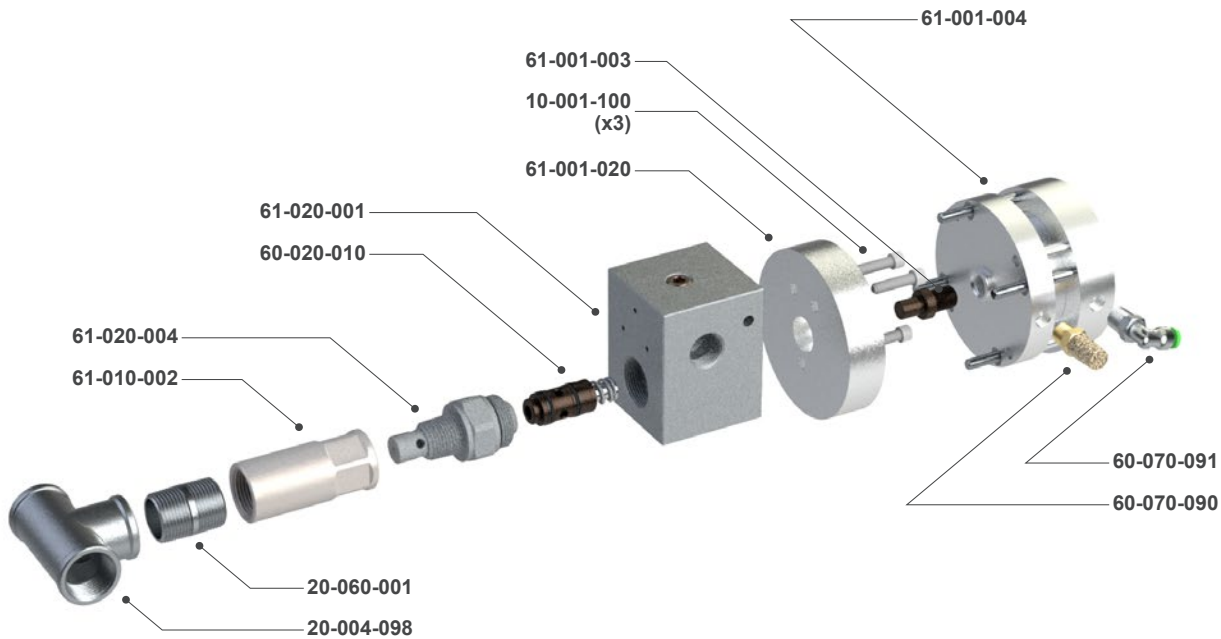

PART NO.	BILL OF MATERIALS (Assembly No. 61-020-020.1)	QUANTITY
10-001-100	1/4"-20 X 1" LONG STAINLESS STEEL SHCS SCREW (MIN YIELD 70K)	3
20-004-098	3/4" NPT 316 STAINLESS STEEL THREADED TEE (150# CLASS)	1
20-060-001	3/4" NPT 316 SCH. 40 CLOSE NIPPLE (150 PSI)	1
60-020-010	20K HAND/FOOT GUN CARTRIDGE ASSEMBLY (J/S TYPE: 51869)	1
60-070-090	1/4" NPTM BRONZE SINTERRED MUFFLER	1
60-070-091	1/4" NPTM X 1/4" PUSH-LOK 90° PARKER SWIVEL ELBOW (300 MAX PSI)	1
61-001-003	15/20K AIR ACTUATOR VALVE PLUNGER	1
61-001-004	15/20K BIMBA AIR ACTUATED CYLINDER	1
61-001-020	20K AIR ACTUATOR FOOT GUN PLATE	1
61-010-002	FOOT GUN DUMP TUBE	1
61-020-001	20K BLACK MACHINED FOOT GUN W/ PLUG	1
61-020-004	20K FOOT GUN DUMP ADAPTER	1

20K psi AIR DIVERTER VALVE w/o RISER & BASE PLATE

Assembly No. 61-020-020.1

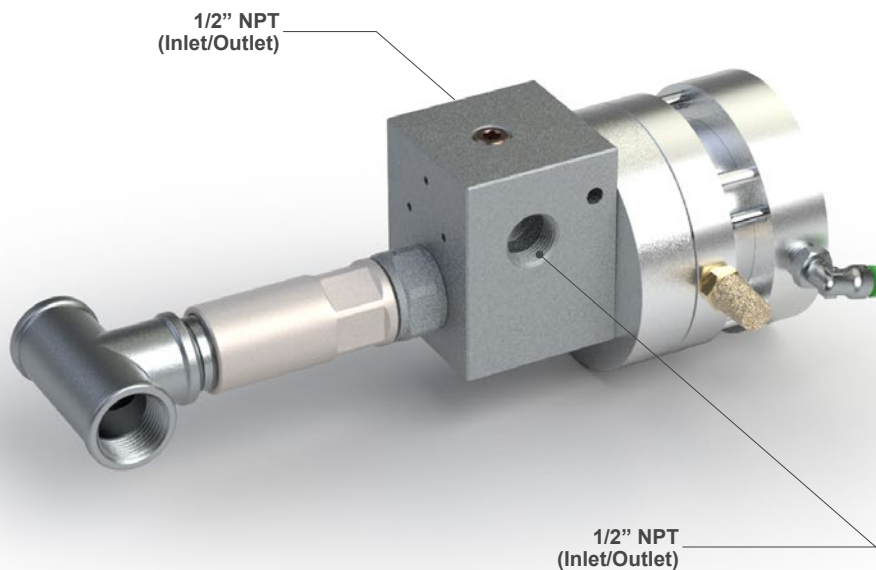

Paired for 20K psi Air Divider Valve w/o Riser & Base Plate...



21-007-005

9/16" MPM X 13MM (1"-12) TYPE M MALE 20K ADAPTER
(GDWJ TYPE: 77211024)



21-007-026

9/16" MPM X 9/16" MPM ADAPTER
(20K MAWP)



21-025-001

9/16" MPF SCREW TYPE COUPLING ASSEMBLY
(20K MAWP)

40-015-4343-050C

4113ST X 50' 20.4K 13MM TYPE M STAINLESS STEEL FLEX LANCE
B/E W/ COVER (BLUE) (J/S TYPE: 28347-05042421) (PARKER)

40K psi AIR DIVERTER VALVE w/o BASE PLATE

Assembly No. 61-040-007

Air Operated Diverter Valves provide much improved operator safety by allowing control of flow and pressure to be carried out remotely. When air is sent to the cylinder, the valve closes and allows the system to build pressure. The valve opens when the air is exhausted, reducing system pressure to near atmospheric.

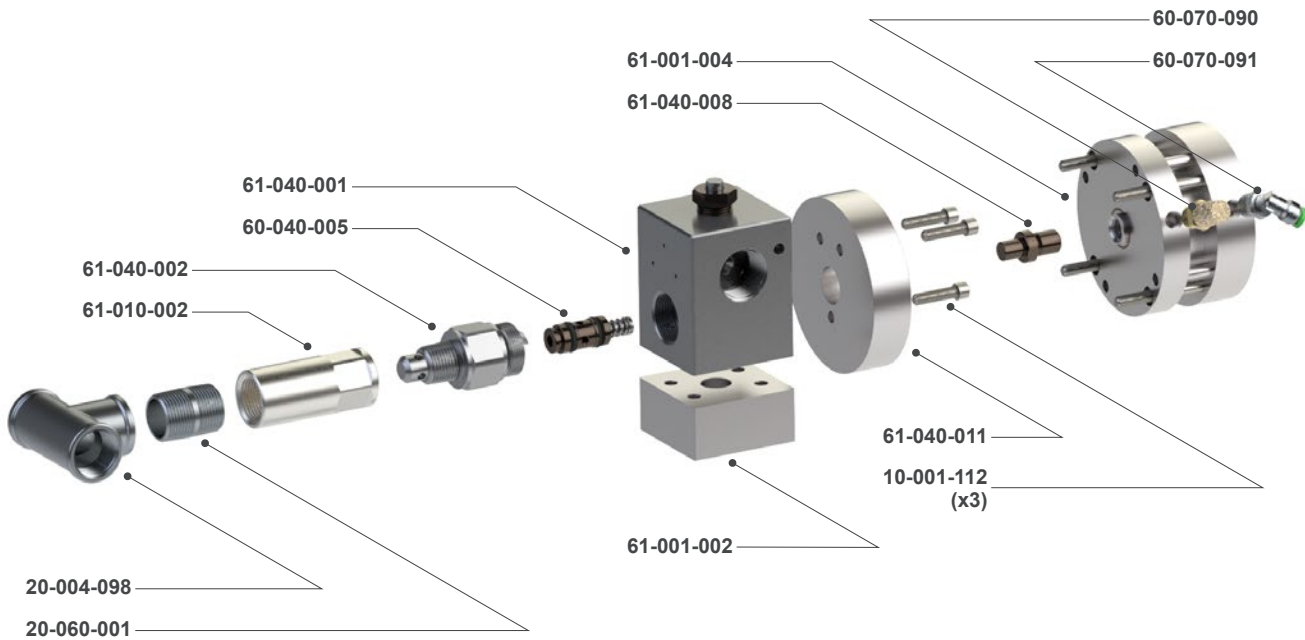

PART NO.	BILL OF MATERIALS (Assembly No. 61-040-007)	QUANTITY
10-001-112	1/4"-20 X 1-1/8" LONG STAINLESS STEEL SHCS SCREW (MIN YIELD 70K)	3
10-001-200	1/4"-20 X 2" LONG STAINLESS STEEL SHCS SCREW (MIN YIELD 70K)	4
20-004-098	3/4" NPT 316 STAINLESS STEEL THREADED TEE (150# CLASS)	1
20-060-001	3/4" 316 SCH. 40 CLOSE NIPPLE (150 PSI)	1
60-040-001D	COMPLETE 40K HAND GUN BLOCK DECAL	1
60-040-005	40K HAND/FOOT GUN CARTRIDGE ASSEMBLY (J/S TYPE: 53475)	1
60-070-090	1/4" NPTM BRONZE SINTERRED MUFFLER	1
60-070-091	1/4" NPTM X 1/4" PUSH-LOK 90° PARKER SWIVEL ELBOW (300 MAX PSI)	1
61-001-002	15K AIR ACTUATOR RISER BLOCK	1
61-001-004	15/20K BIMBA AIR ACTUATED CYLINDER	1
61-010-002	FOOT GUN DUMP TUBE	1
61-020-005	20/40K FOOT GUN & 12K HIGH FLOW FOOT GUN PIVOT PIN	1
61-040-001	40K MACHINED FOOT GUN BLOCK ASSEMBLY	1
61-040-002	40K FOOT GUN DUMP ADAPTER ASSEMBLY	1
61-040-008	40K AIR ACTUATOR VALVE PLUNGER	1
61-040-011	40K AIR ACTUATOR FOOT GUN PLATE	1

40K psi AIR DIVERTER VALVE w/o BASE PLATE

Assembly No. 61-040-007

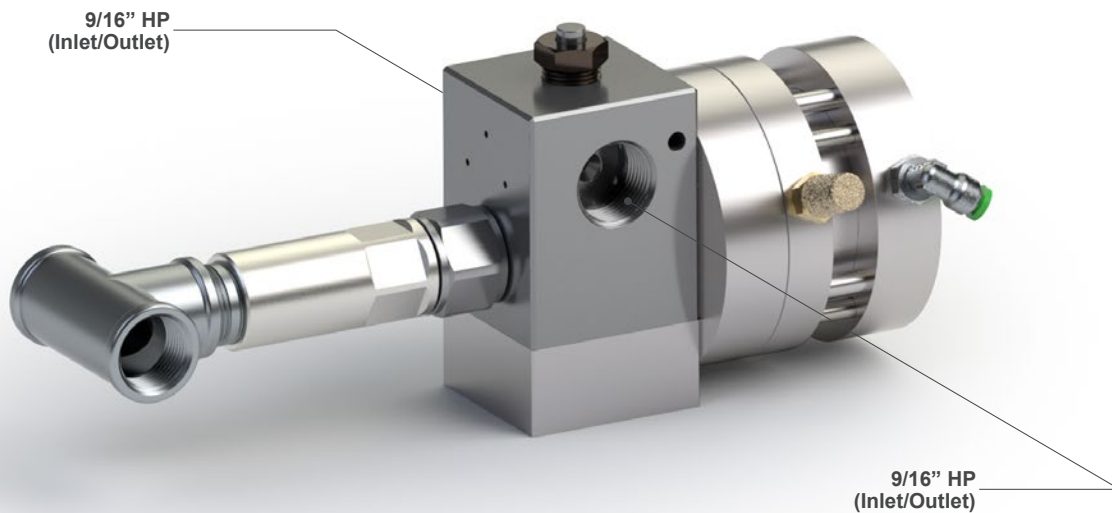

Paired for 40K psi Air Divider Valve w/o Base Plate...

22-012-004
 9/16" HPM X 5MM (9/16"-18) TYPE M 40K STAINLESS STEEL ADAPTER (GDWJ TYPE: 77211048)

22-012-006
 9/16" HPM X 7/8 (7/8"-14) TYPE M 40K STAINLESS STEEL ADAPTER (GDWJ TYPE: 77211047) (HP9 X M14)

40-024-4242-050C
 8108ST X 50' 44K 7/8"-14 STAINLESS STEEL TYPE M SWIVEL FLEX LANCE B/E W/ PVC COVER (2840D-05V35 - DN8-5/16")

43-010-002
 NYLON 1-PLY SAFETY WHIP CHECK W/ RUBBER GROMMET STOPS (APPROXIMATELY 31-1/2" LONG)

15K psi AIR DIVERTER VALVE

Assembly No. 61-001-007

An Air Operated Dump Valve allows an operator to remotely control pressure in cleaning applications from 15K psi. When air is sent to the cylinder, the valve closes and allows the system to build pressure. The valve opens when the air is exhausted, reducing system pressure to near atmospheric.

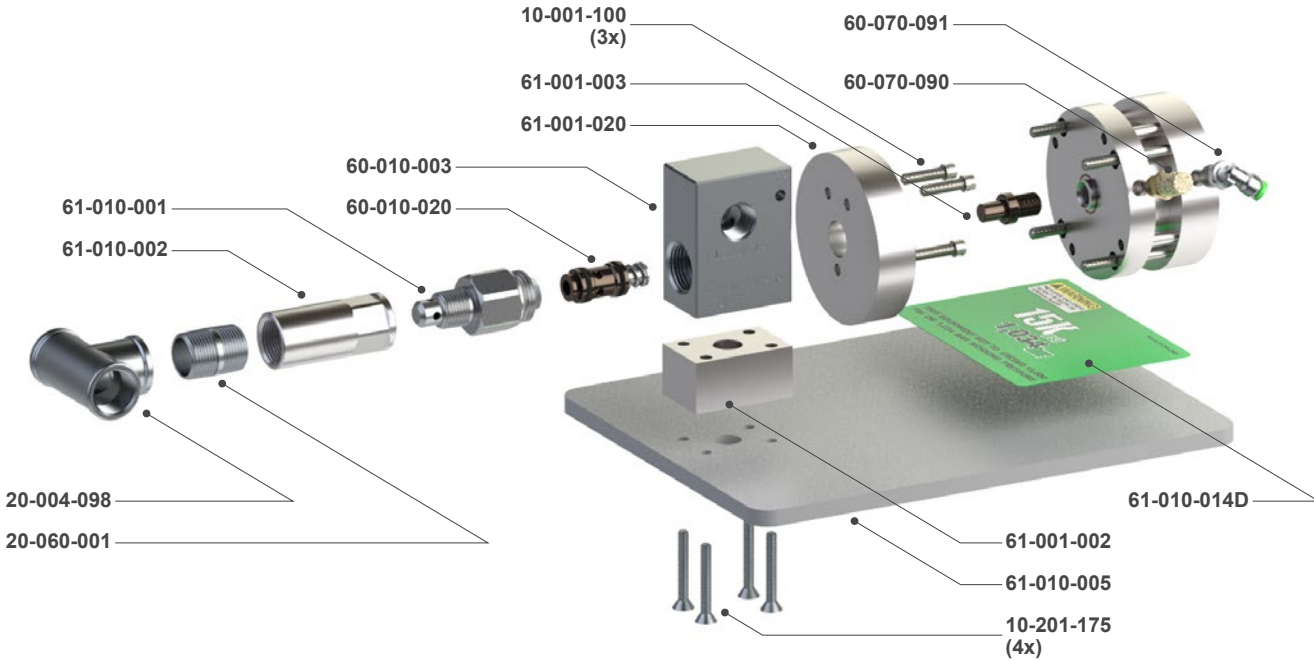

PART NO.	BILL OF MATERIALS (Assembly No. 61-001-007)	QUANTITY
10-001-125	1/4"-20 X 1-1/4" LONG STAINLESS STEEL SHCS SCREW (MIN YIELD 70K)	3
10-001-200	1/4"-20 X 2" LONG STAINLESS STEEL SHCS SCREW (MIN YIELD 70K)	4
10-201-175	1/4"-20 X 1-3/4" STAINLESS STEEL FLAT HEAD SOCKET CAP SCREW	4
20-004-098	3/4" NPT 316 STAINLESS STEEL THREADED TEE (150# CLASS)	1
20-060-001	3/4" 316 SCH. 40 CLOSE NIPPLE (150 PSI)	1
60-010-020	15K HAND/FOOT GUN CARTRIDGE ASSEMBLY (J/S TYPE: 50902)	1
60-070-090	1/4" NPTM BRONZE SINTERED MUFFLER	1
60-070-091	1/4" NPTM X 1/4" PUSH-LOK 90° PARKER SWIVEL ELBOW (300 MAX PSI)	1
61-001-002	15K AIR ACTUATOR RISER BLOCK	1
61-001-003	15/20K AIR ACTUATOR VALVE PLUNGER	1
61-001-004	15/20K BIMBA AIR ACTUATED CYLINDER	1
61-001-020	20K AIR ACTUATOR FOOT GUN PLATE	1
61-010-001	15K FOOT GUN DUMP ADAPTER	1
61-010-002	FOOT GUN DUMP TUBE	1
61-010-003	15K FOOT GUN BLOCK	1
61-010-005	STANDARD FOOT GUN BASE PLATE (UNPAINTED)	1
61-010-014D	15K FOOT GUN ASSEMBLY DECAL	1

15K psi AIR DIVERTER VALVE

Assembly No. 61-001-007

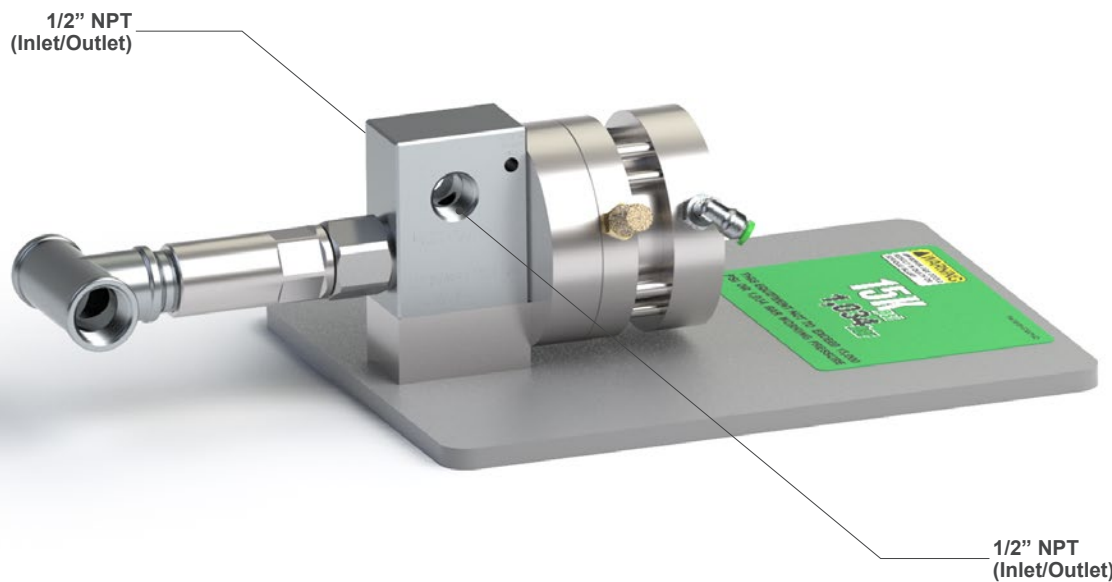

Paired for 15K psi Air Divider Valve...



20-003-008
1/2" NPT SCREW TYPE COUPLING ASSEMBLY (15K MAWP)
(J/S TYPE: 50989)



20-011-008
1/2" NPTM X 1/2" NPTM HEX NIPPLE (15K MAWP)
(GDWJ TYPE: 3432509) (J/S TYPE: 50488)



43-004-050
1/2" NPT B/E X 50' 15K RUBBER WATERBLAST HOSE (CERTIFIED & TESTED) (GDWJ TYPE: 6122054050) (J/S TYPE: 52241-0500505)

XX-XXX-XXX
XXXXX

20K psi AIR DIVERTER VALVE

Assembly No. 61-020-019

Air Operated Diverter Valves provide much improved operator safety by allowing control of flow and pressure to be carried out remotely. When air is sent to the cylinder, the valve closes and allows the system to build pressure. The valve opens when the air is exhausted, reducing system pressure to near atmospheric.

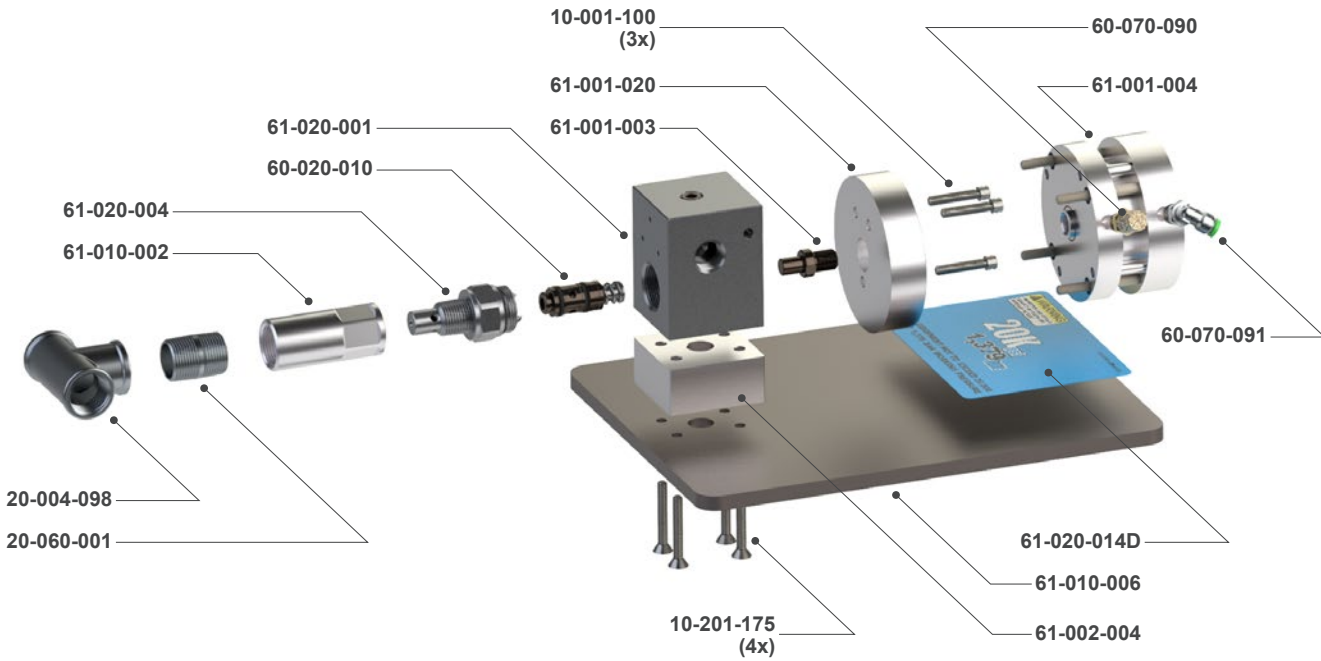

PART NO.	BILL OF MATERIALS (Assembly No. 61-020-019)	QUANTITY
10-001-100	1/4"-20 X 1" LONG STAINLESS STEEL SHCS SCREW (MIN YIELD 70K)	3
10-201-175	1/4"-20 X 1-3/4" STAINLESS STEEL FLAT HEAD SOCKET CAP SCREW	4
20-004-098	3/4" NPT 316 STAINLESS STEEL THREADED TEE (150# CLASS)	1
20-060-001	3/4" 316 SCH. 40 CLOSE NIPPLE (150 PSI)	1
60-020-010	20K HAND/FOOT GUN CARTRIDGE ASSEMBLY (J/S TYPE: 51869)	1
60-070-090	1/4" NPTM BRONZE SINTERRED MUFFLER	1
60-070-091	1/4" NPTM X 1/4" PUSH-LOK 90° PARKER SWIVEL ELBOW (300 MAX PSI)	1
61-001-003	15/20K AIR ACTUATOR VALVE PLUNGER	1
61-001-004	15/20K BIMBA AIR ACTUATED CYLINDER	1
61-001-020	20K STAINLESS STEEL AIR ACTUATOR FOOT GUN PLATE	1
61-002-004	20K AIR ACTUATOR FOOT GUN RISER BLOCK	1
61-010-002	FOOT GUN DUMP TUBE	1
61-010-006	PAINTED AIR OPERATED FOOT GUN BASE PLATE	1
61-020-001	20K MACHINED FOOT GUN BLOCK W/ PLUG	1
61-020-004	20K FOOT GUN DUMP ADAPTER	1
61-020-014D	20K FOOT GUN DECAL	1

20K psi AIR DIVERTER VALVE

Assembly No. 61-020-019

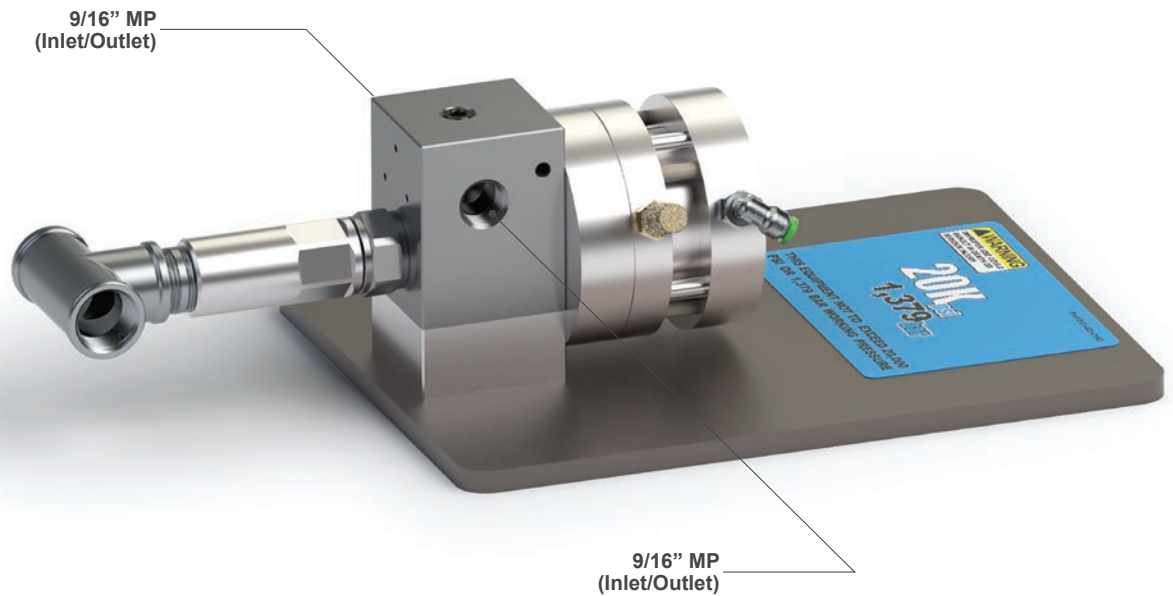

Paired for 20K psi Air Divider Valve...



21-007-005

9/16" MP M X 13MM (1"-12) TYPE M MALE 20K ADAPTER
(GDWJ TYPE: 77211024)



21-007-026

9/16" MPM X 9/16" MPM ADAPTER
(20K MAWP)



21-025-001

9/16" MPF SCREW TYPE COUPLING ASSEMBLY
(20K MAWP)

40-015-4343-050C

4113ST X 50' 20.4K 13MM TYPE M STAINLESS STEEL FLEX LANCE
B/E W/ COVER (BLUE) (J/S TYPE: 28347-05042421) (PARKER)

40K psi AIR DIVERTER VALVE

Assembly No. 61-040-006

Air Operated Diverter Valves provide much improved operator safety by allowing control of flow and pressure to be carried out remotely. When air is sent to the cylinder, the valve closes and allows the system to build pressure. The valve opens when the air is exhausted, reducing system pressure to near atmospheric.

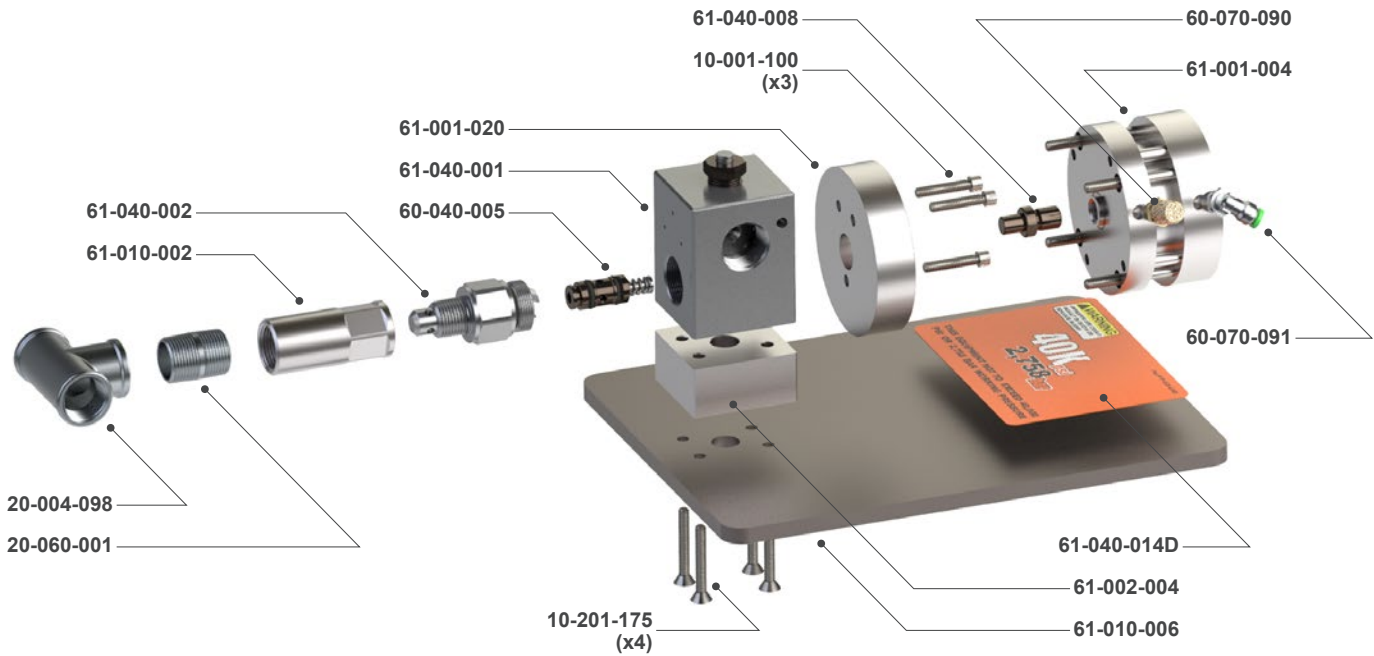

PART NO.	BILL OF MATERIALS (Assembly No. 61-040-006)	QUANTITY
10-001-100	1/4"-20 X 1" LONG STAINLESS STEEL SHCS SCREW	3
10-201-175	1/4"-20 X 1-3/4" STAINLESS STEEL FLAT HEAD SOCKET CAP SCREW	4
20-004-098	3/4" NPT 316 STAINLESS STEEL THREADED TEE (150# CLASS)	1
20-060-001	3/4" NPT 316 SCH. 40 CLOSE NIPPLE (150 PSI)	1
60-040-005	40K HAND/FOOT GUN CARTRIDGE ASSEMBLY (J/S TYPE: 53475)	1
60-070-090	1/4" NPTM BRONZE SINTERED MUFFLER	1
60-070-091	1/4" NPTM X 1/4" PUSH-LOK 90° PARKER SWIVEL ELBOW (300 MAX PSI)	1
61-001-004	15/20K BIMBA AIR ACTUATED CYLINDER	1
61-001-020	20K AIR ACTUATOR FOOT GUN PLATE	1
61-002-004	20K AIR ACTUATOR FOOT GUN RISER BLOCK	1
61-010-002	FOOT GUN DUMP TUBE	1
61-010-006	PAINTED AIR OPERATED FOOT GUN BASE PLATE	1
61-040-001	40K MACHINED FOOT GUN BLOCK ASSEMBLY	1
61-040-002	40K FOOT GUN DUMP ADAPTER ASSEMBLY	1
61-040-008	40K AIR ACTUATOR VALVE PLUNGER	1
61-040-014D	40K FOOT GUN DECAL	1

40K psi AIR DIVERTER VALVE

Assembly No. 61-040-006

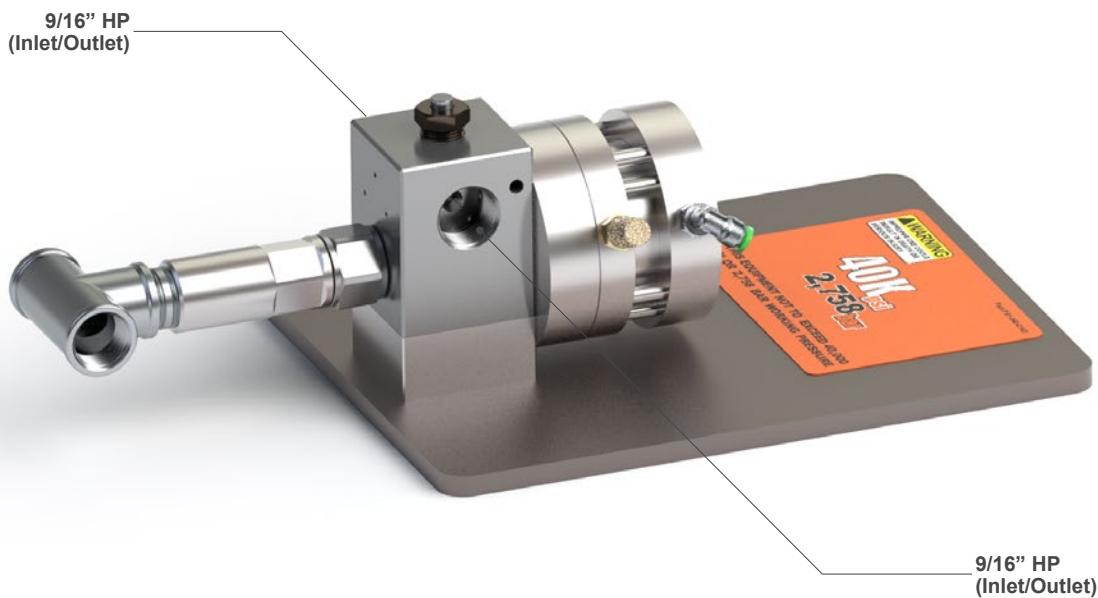

9/16" HP
(Inlet/Outlet)

9/16" HP
(Inlet/Outlet)

Paired for 40K psi Air Divider Valve...

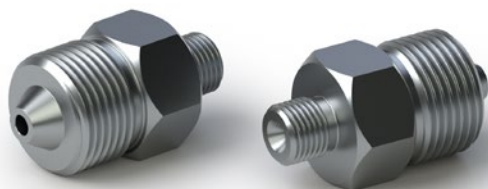

22-012-004

9/16" HPM X 5MM (9/16"-18) TYPE M 40K STAINLESS STEEL ADAPTER (GDWJ TYPE: 77211048)



22-012-006

9/16" HPM X 7/8 (7/8"-14) TYPE M 40K STAINLESS STEEL ADAPTER (GDWJ TYPE: 77211047) (HP9 X M14)



40-024-4242-050C

8108ST X 50' 44K 7/8"-14 STAINLESS STEEL TYPE M SWIVEL FLEX LANCE, B/E W/ PVC COVER (2840D-05V35 - DN8-5/16")



43-010-002

NYLON 1-PLY SAFETY WHIP CHECK W/ RUBBER GROMMET STOPS (APPROXIMATELY 31-1/2" LONG)

15K psi HIGH VOLUME AIR DIVERTER VALVE w/o BASE PLATE

Assembly No. 61-050-015

A High Volume Air Operated Dump Valve allows an operator to remotely control pressure in cleaning applications from 15K psi. When air is sent to the cylinder, the valve closes and allows the system to build pressure. The valve opens when the air is exhausted, reducing system pressure to near atmospheric.

Features:

- 30-second field replaceable cartridge design for minimal downtime
- Remote pneumatic operation for reduced operator fatigue and added convenience and safety
- Heavy duty air cylinder
- All components precision machined from stainless steel

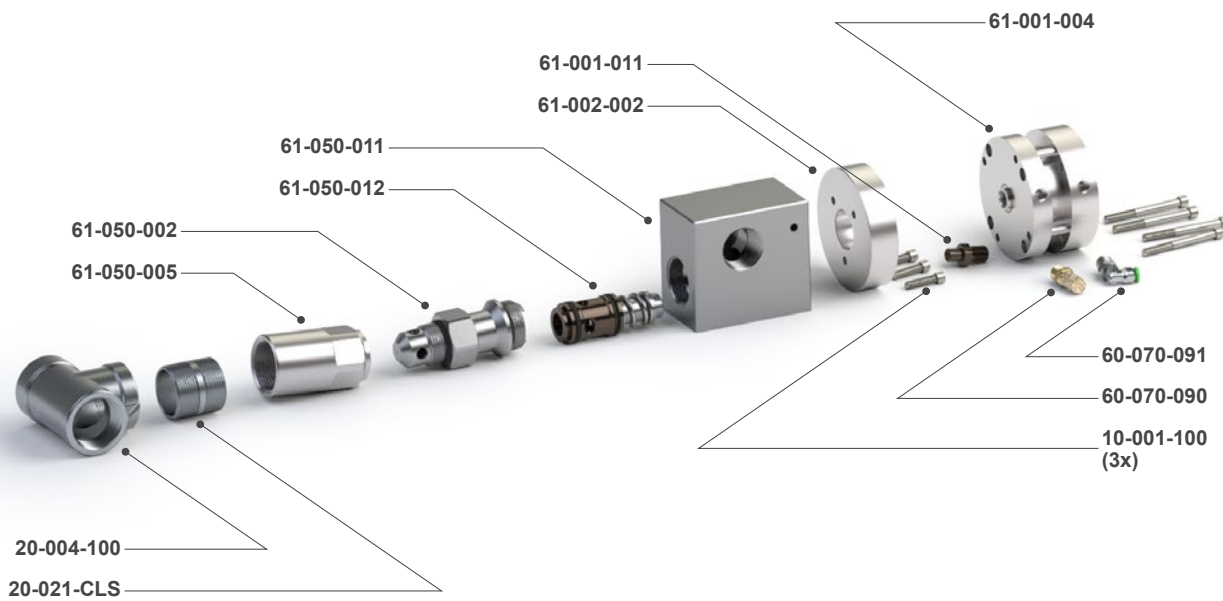

PART NO.	BILL OF MATERIALS (Assembly No. 61-050-015)	QUANTITY
10-001-100	1/4"-20 X 1" LONG STAINLESS STEEL SHCS SCREW	3
20-004-100	1-1/4" NPT 316 STAINLESS STEEL THREADED TEE (150# CLASS)	1
20-021-CLS	1-1/4" NPT X CLS (1.625") 10K 304 STAINLESS STEEL NIPPLE	1
60-070-090	1/4" NPTM BRONZE SINTERRED MUFFLER	1
60-070-091	1/4" NPTM X 1/4" PUSH-LOK 90° PARKER SWIVEL ELBOW (300 MAX PSI)	1
61-001-004	15/20K BIMBA AIR ACTUATED CYLINDER	1
61-001-011	AIR ACTUATOR VALVE PLUNGER	1
61-002-002	20K AIR ACTUATOR FOOT GUN PLATE	1
61-050-002	HIGH FLOW FOOT GUN DUMP ADAPTER	1
61-050-005	HIGH FLOW FOOT GUN DUMP TUBE	1
61-050-011	15K HIGH FLOW FOOT GUN BLOCK	1
61-050-012	15K HIGH FLOW FOOT GUN CARTRIDGE ASSEMBLY	1
61-050-013	15K HIGH VOLUME FOOT GUN ASSEMBLY DUMP DEFLECTOR	1

15K psi HIGH VOLUME AIR DIVERTER VALVE w/o BASE PLATE

Assembly No. 61-050-015

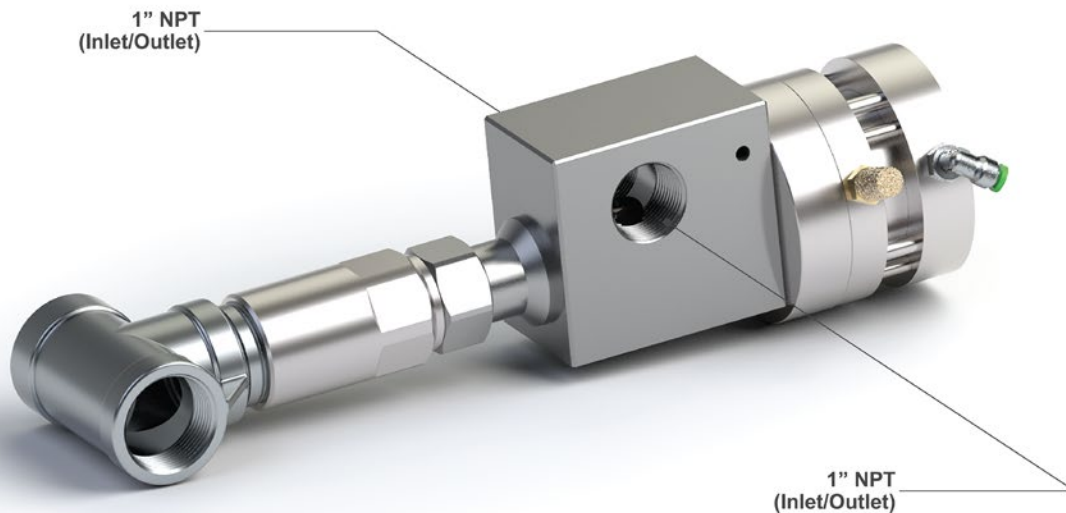

Paired for 15K psi High Volume Air Divider Valve w/o Base Plate...



20-003-016

1" NPT SCREW TYPE COUPLING ASSEMBLY
(12K MAWP)



20-011-013

1" NPTM X 1" NPTM HEX NIPPLE
(12K MAWP)



43-008-050

1" NPT B/E X 50' 10K WATERBLAST RUBBER HOSE
(CERTIFIED & TESTED)

XX-XXX-XXX

XXXXX

20K psi HIGH VOLUME AIR DIVERTER VALVE w/o BASE PLATE

Assembly No. 61-020-034.1

A High Volume Air Operated Dump Valve allows an operator to remotely control pressure in cleaning applications up to 22K psi. When air is sent to the cylinder, the valve closes and allows the system to build pressure. The valve opens when the air is exhausted, reducing system pressure to near atmospheric.

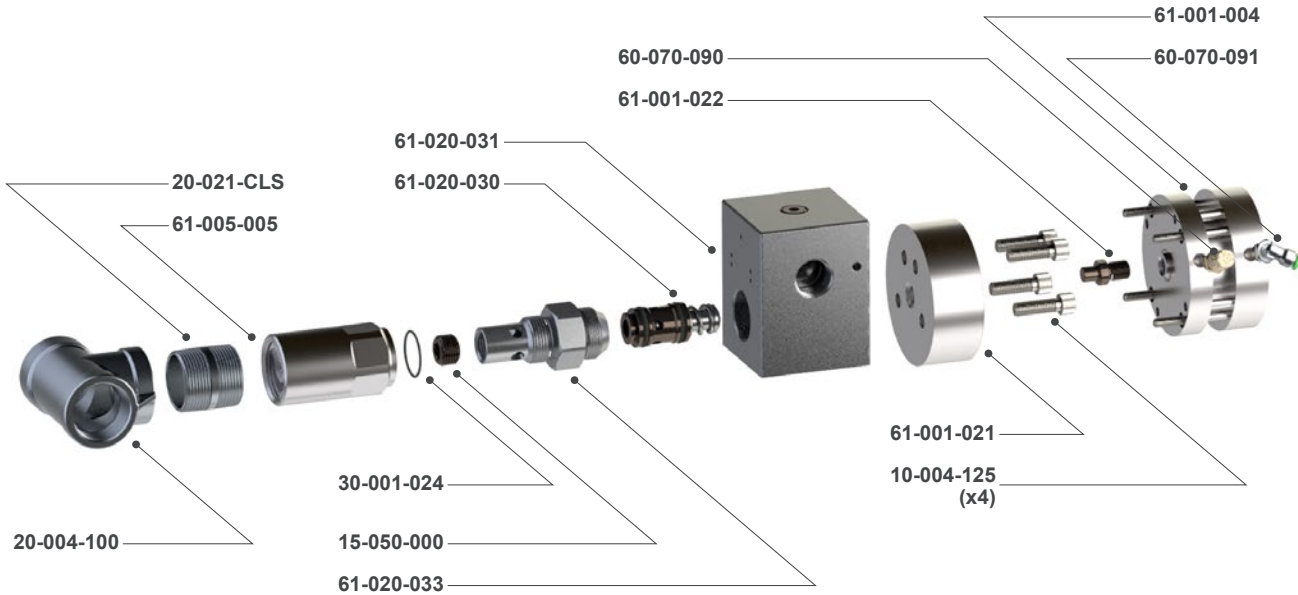

PART NO.	BILL OF MATERIALS (Assembly No. 61-020-034.1)	QUANTITY
10-004-125	3/8"-16 X 1-1/4" LONG STAINLESS STEEL SHCS SCREW	4
15-050-000	1/2" NPT STAINLESS STEEL SOCKET HEAD PIPE PLUG	1
20-004-100	1-1/4" NPT 316 STAINLESS STEEL THREADED TEE (150# CLASS)	1
20-021-CLS	1-1/4" NPT X CLS (1.625") 10K 304 STAINLESS STEEL NIPPLE	1
30-001-024	2-024 BUNA-N 90 DURO O-RING	1
60-070-090	1/4" NPTM BRONZE SINTERRED MUFFLER	1
60-070-091	1/4" NPTM X 1/4" PUSH-LOK 90° PARKER SWIVEL ELBOW (300 MAX PSI)	1
61-001-004	15/20K BIMBA AIR ACTUATED CYLINDER	1
61-001-021	20K STAINLESS STEEL AIR ACTUATOR FOOT GUN PLATE	1
61-001-022	STAINLESS STEEL AIR ACTUATED DIVERTER VALVE PISTON	1
61-020-030	15/20K CF MAG CARTRIDGE ASSEMBLY (J/S TYPE: 52750)	1
61-020-031	20K HIGH FLOW FOOT GUN BLOCK	1
61-020-033	20K HIGH FLOW FOOT GUN DUMP ADAPTER	1
61-050-005	HIGH FLOW FOOT GUN DUMP TUBE	1

20K psi HIGH VOLUME AIR DIVERTER VALVE w/o BASE PLATE

Assembly No. 61-020-034.1

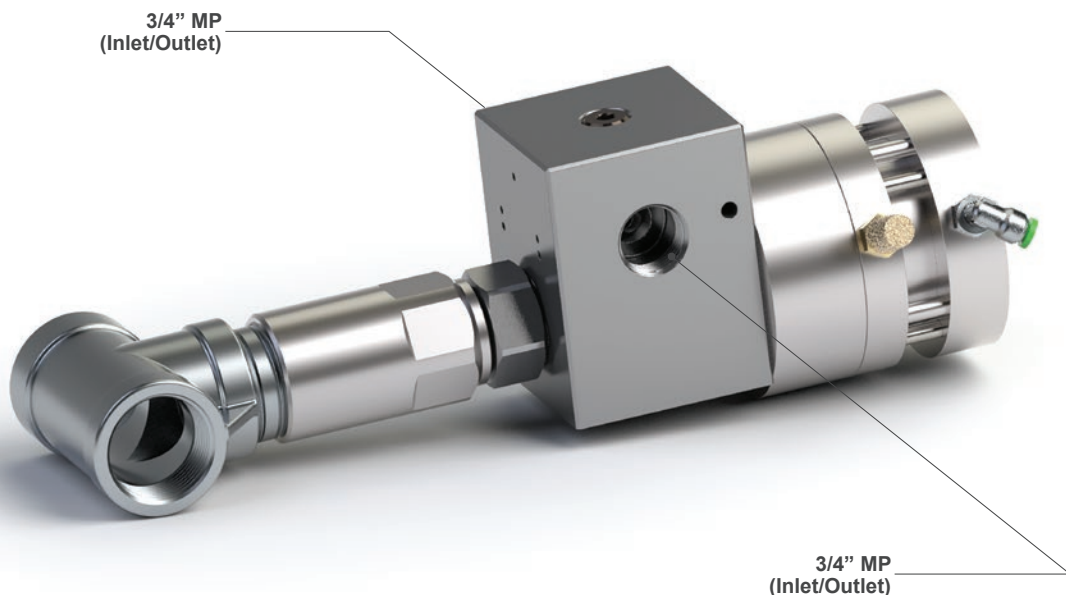

3/4" MP
(Inlet/Outlet)

3/4" MP
(Inlet/Outlet)

Paired for 20K psi High Volume Air Divider Valve w/o Base Plate...



21-007-008

3/4" MPM X 13MM (1"-12) TYPE M MALE 20K ADAPTER
(GDWJ TYPE: 77211026 OR AF 063-MP12)

21-025-006

3/4" MP SCREW TYPE COUPLING ASSEMBLY
(20K MAWP)

40-015-4343-050C

4113ST X 50' 20.4K 13MM TYPE M STAINLESS STEEL FLEX LANCE
B/E W/ COVER (BLUE) (J/S TYPE: 28347-05042421) (PARKER)

XX-XXX-XXX

INSERT DESCRIPTION HERE
...

15K psi HIGH VOLUME AIR DIVERTER VALVE

Assembly No. 61-050-014

A High Volume Air Operated Dump Valve allows an operator to remotely control pressure in cleaning applications from 15K psi. When air is sent to the cylinder, the valve closes and allows the system to build pressure. The valve opens when the air is exhausted, reducing system pressure to near atmospheric.

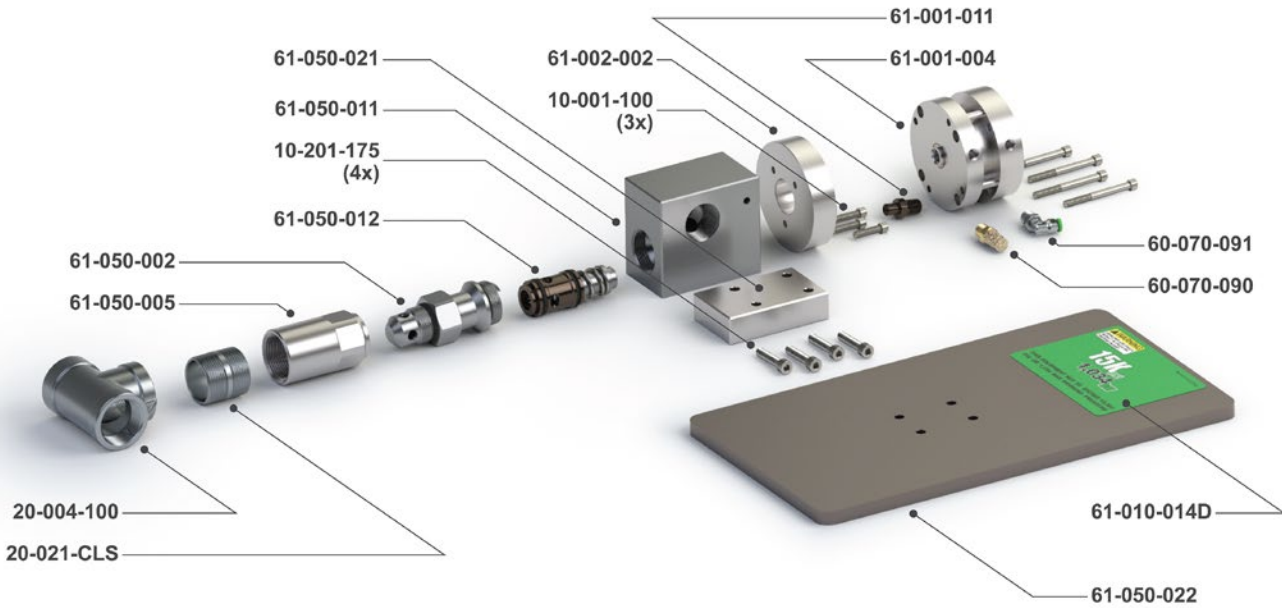

PART NO.	BILL OF MATERIALS (Assembly No. 61-050-014)	QUANTITY
10-001-100	1/4"-20 X 1" LONG STAINLESS STEEL SHCS SCREW	3
10-002-150	5/16"-18 X 1-1/2" LONG STAINLESS STEEL SHCS SCREW	4
20-004-100	1-1/4" NPT 316 STAINLESS STEEL THREADED TEE (150# CLASS)	1
20-021-CLS	1-1/4" NPT X CLS (1.625") 304 STAINLESS STEEL NIPPLE	1
60-070-090	1/4" NPTM BRONZE SINTERRED MUFFLER	1
60-070-091	1/4" NPTM X 1/4" PUSH-LOK 90° PARKER SWIVEL ELBOW (300 MAX PSI)	1
61-001-004	15/20K BIMBA AIR ACTUATED CYLINDER	1
61-001-011	AIR ACTUATOR VALVE PLUNGER	1
61-002-002	20K AIR ACTUATOR FOOT GUN PLATE	1
61-010-014D	15K FOOT GUN ASSEMBLY DECAL	1
61-050-002	15K HIGH VOLUME FOOT GUN DUMP TUBE ADAPTER	1
61-050-005	HIGH FLOW FOOT GUN DUMP TUBE	1
61-050-011	15K HIGH FLOW FOOT GUN BLOCK	1
61-050-012	15K HIGH FLOW FOOT GUN CARTRIDGE ASSEMBLY (J/S TYPE: 53915)	1
61-050-013	15K HIGH VOLUME FOOT GUN ASSEMBLY DUMP DEFLECTOR	1
61-050-021	HIGH FLOW FOOT GUN SUPPORT BLOCK	1
61-050-022	HIGH FLOW AIR ACTUATED FOOT GUN BASE PLATE	1

15K psi HIGH VOLUME AIR DIVERTER VALVE

Assembly No. 61-050-014

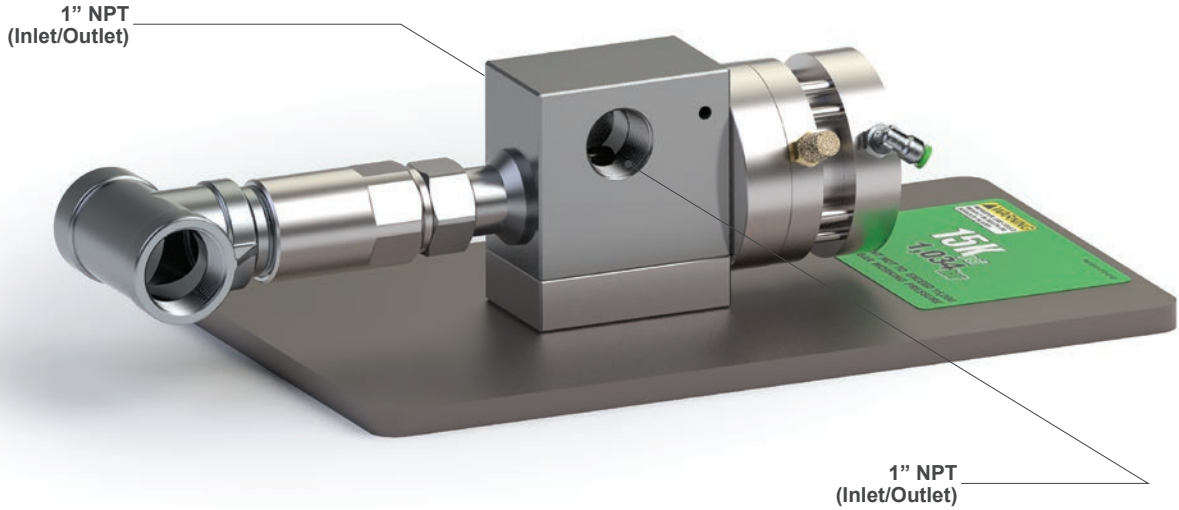

Paired for 15K psi High Volume Air Divider Valve...

20-003-016
1" NPT SCREW TYPE COUPLING ASSEMBLY
(12K MAWP)

20-011-013
1" NPTM X 1" NPTM HEX NIPPLE
(12K MAWP)

43-008-050
1" NPT B/E X 50' 10K WATERBLAST RUBBER HOSE
(CERTIFIED & TESTED)

XX-XXX-XXX
XXXXX

20K psi HIGH VOLUME AIR DIVERTER VALVE

Assembly No. 61-020-034.2

A High Volume Air Operated Dump Valve allows an operator to remotely control pressure in cleaning applications up to 22K psi. When air is sent to the cylinder, the valve closes and allows the system to build pressure. The valve opens when the air is exhausted, reducing system pressure to near atmospheric.

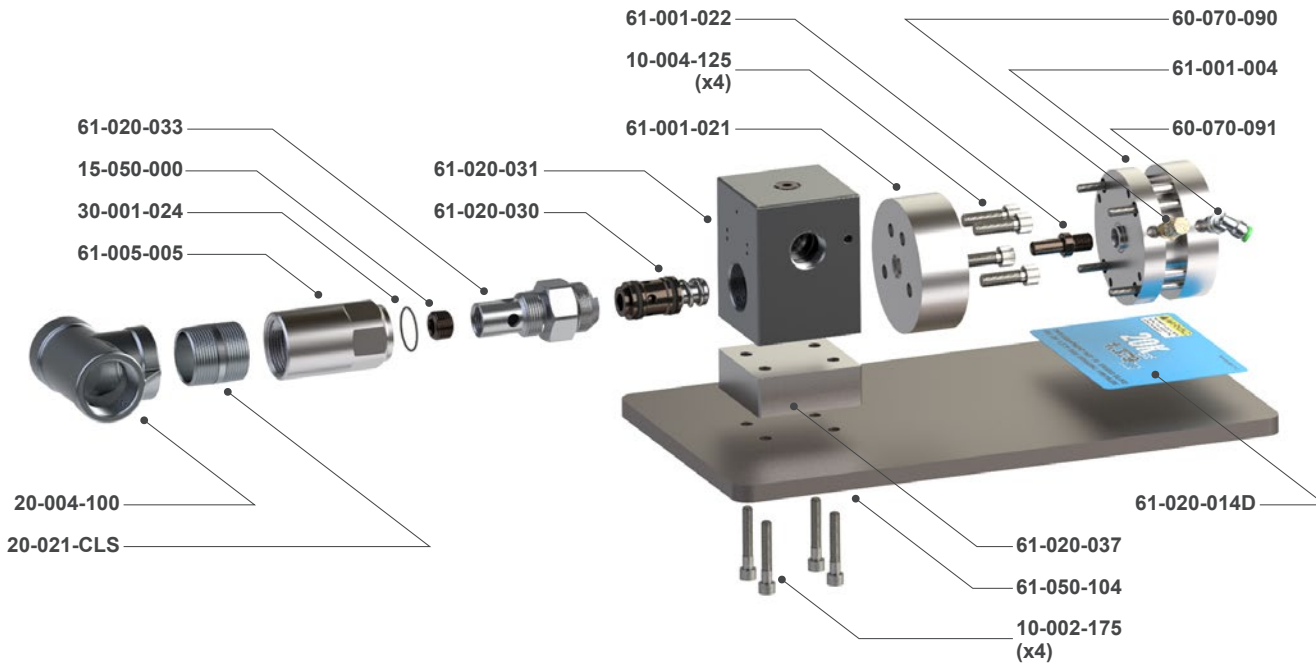

PART NO.	BILL OF MATERIALS (Assembly No. 61-020-034.2)	QUANTITY
10-002-175	5/16"-18 X 1-3/4" LONG STAINLESS STEEL SHCS SCREW	4
10-004-125	3/8"-16 X 1-1/4" LONG STAINLESS STEEL SHCS SCREW	4
15-050-000	1/2" NPT 15K STAINLESS STEEL SOCKET HEAD PIPE PLUG	1
20-004-100	1-1/4" NPT 316 STAINLESS STEEL THREADED TEE (150# CLASS)	1
20-021-CLS	1-1/4" NPT X CLS (1.625") 10K 304 STAINLESS STEEL NIPPLE	1
30-001-024	2-024 BUNA-N 90 DURO O-RING	1
60-070-090	1/4" NPTM BRONZE SINTERED MUFFLER	1
60-070-091	1/4" NPTM X 1/4" PUSH-LOK 90° PARKER SWIVEL ELBOW (300 MAX PSI)	1
61-001-004	15/20K BIMBA AIR ACTUATED CYLINDER	1
61-001-021	20K STAINLESS STEEL AIR ACTUATOR FOOT GUN PLATE	1
61-001-022	STAINLESS STEEL AIR ACTUATED DIVERTER VALVE PISTON	1
61-020-014D	20K FOOT GUN DECAL	1
61-020-030	15/20K CF MAG CARTRIDGE ASSEMBLY (J/S TYPE: 52750)	1
61-020-031	20K HIGH FLOW FOOT GUN BLOCK	1
61-020-033	20K HIGH FLOW FOOT GUN DUMP ADAPTER	1
61-020-037	HIGH FLOW AIR OPERATED DIVERTER VALVE SPACER BLOCK W/ BASE	1
61-050-005	HIGH FLOW FOOT GUN DUMP TUBE	1
61-050-104	PAINTED HIGH FLOW FOOT GUN BASE PLATE	1

20K psi HIGH VOLUME AIR DIVERTER VALVE

Assembly No. 61-020-034.2

3/4" MP
(Inlet/Outlet)

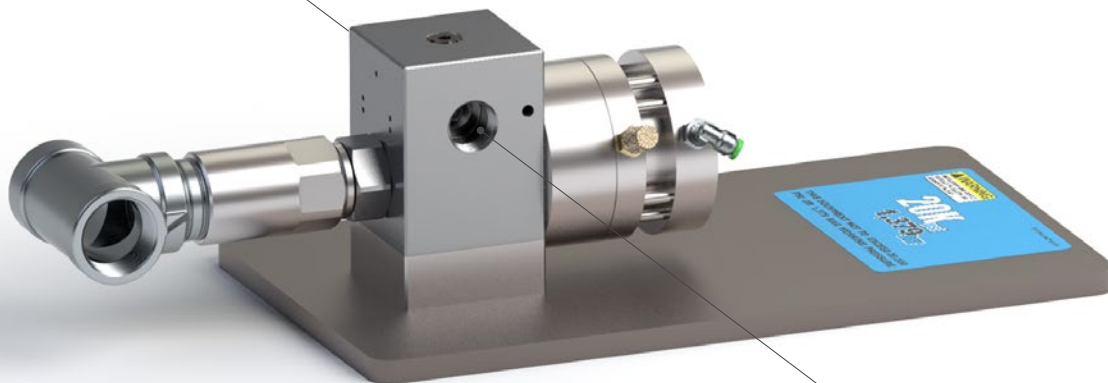

3/4" MP
(Inlet/Outlet)

Paired for 20K psi High Volume Air Divider Valve...



21-007-008

3/4" MPM X 13MM (1"-12) TYPE M MALE 20K ADAPTER
(GDWJ TYPE: 77211026 OR AF 063-MP12)

21-025-006

3/4" MP SCREW TYPE M COUPLING ASSEMBLY
(20K MAWP)

40-015-4343-050C

4113ST X 50' 20.4K 13MM TYPE M STAINLESS STEEL FLEX LANCE
B/E W/ COVER (BLUE) (J/S TYPE: 28347-05042421) (PARKER)

XX-XXX-XXX

INSERT DESCRIPTION HERE
...

15K psi DRY SHUT-OFF AIR DIVERTER VALVE

Assembly No. 61-010-306

Air Operated Diverter Valves provide much improved operator safety by allowing control of flow and pressure to be carried out remotely. When air is sent to the cylinder, the valve closes and allows the system to build pressure. The valve opens when the air is exhausted, reducing system pressure to near atmospheric.

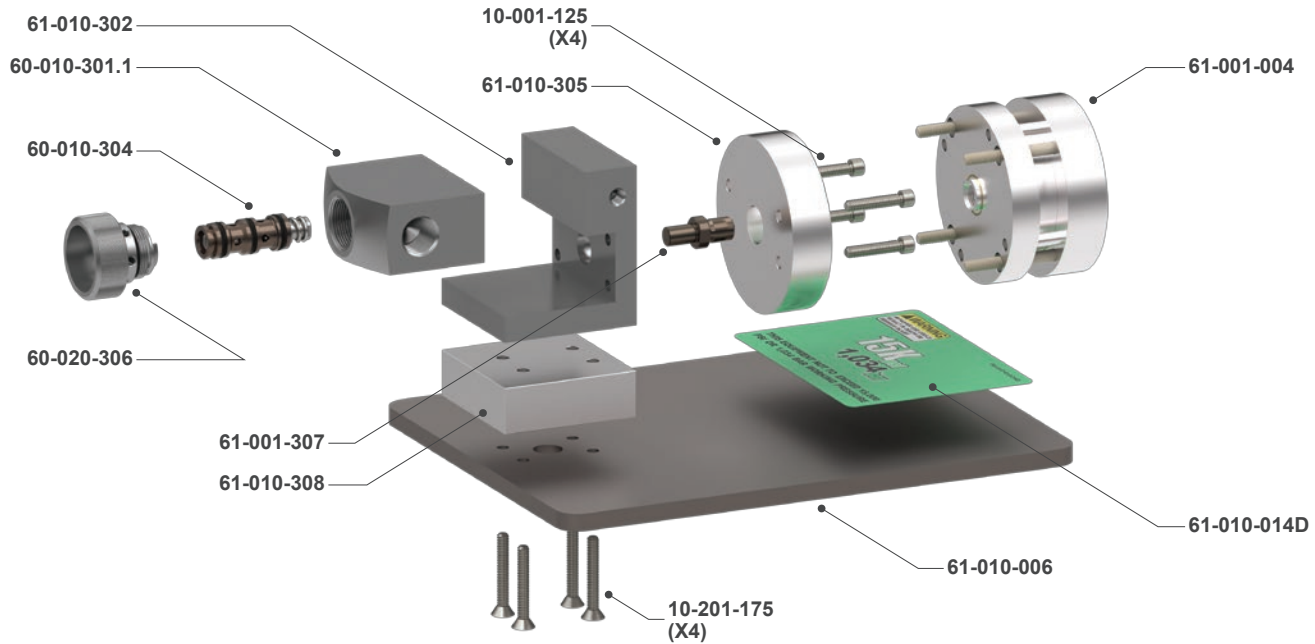

PART NO.	BILL OF MATERIALS (Assembly No. 61-010-306)	QUANTITY
10-001-125	1/4"-20 X 1-1/4" LONG STAINLESS STEEL SHCS SCREW (MIN YIELD 70K)	4
10-201-175	1/4"-20 X 1-3/4" STAINLESS STEEL FLAT HEAD SOCKET CAP SCREW	4
20-004-098	3/4" NPT 316 STAINLESS STEEL THREADED TEE (150# CLASS)	1
20-060-001	3/4" NPT 316 SCH. 40 CLOSE NIPPLE (150 PSI)	1
60-010-301.1	15K MACHINED DRY SHUT-OFF GUN BLOCK	1
60-010-304	15K DRY SHUT-OFF GUN CARTRIDGE ASSEMBLY (J/S TYPE: 52635 OR 60419)	1
60-020-306	20K DRY SHUT-OFF GUN CARTRIDGE NUT	1
60-070-090	1/4" NPTM BRONZE SINTERRED MUFFLER	1
60-070-091	1/4" NPTM X 1/4" PUSH-LOK 90° PARKER SWIVEL ELBOW (300 MAX PSI)	1
61-001-004	15/20K BIMBA AIR ACTUATED CYLINDER	1
61-001-307	15/20K AIR ACTUATOR VALVE PLUNGER	1
61-010-006	PAINTED AIR OPERATED FOOT GUN BASE PLATE	1
61-010-014D	15K FOOT GUN ASSEMBLY DECAL	1
61-010-302	DRY SHUT-OFF FOOT GUN ADAPTER BLOCK	1
61-010-305	DRY SHUT-OFF DIVERTER VALVE ACTUATOR MOUNTING PLATE	1
61-010-308	DRY SHUT-OFF SPACER BLOCK	1

15K psi DRY SHUT-OFF AIR DIVERTER VALVE

Assembly No. 61-010-306

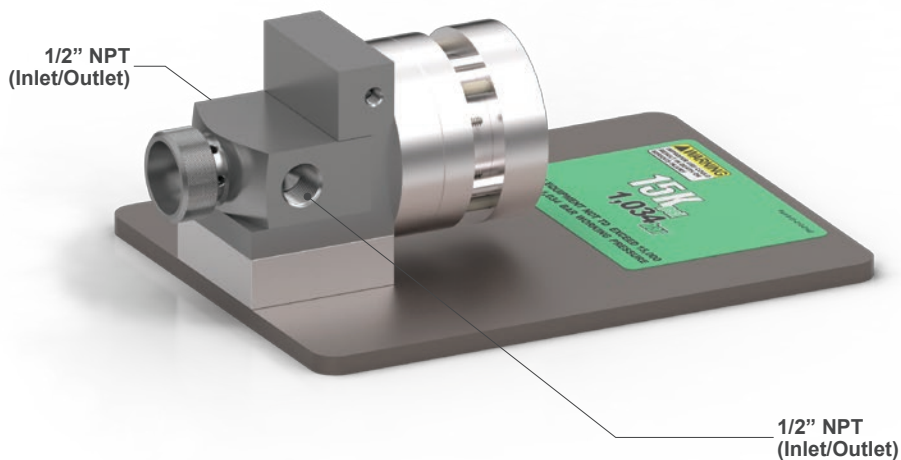

Paired for 15K psi Dry Shut-Off Air Divider Valve...



20-003-008

1/2" NPT SCREW TYPE COUPLING ASSEMBLY (15K MAWP)
(J/S TYPE: 50989)



20-011-008

1/2" NPTM X 1/2" NPTM HEX NIPPLE (15K MAWP)
(GDWJ TYPE: 3432509) (J/S TYPE: 50488)



43-004-050

1/2" NPT B/E X 50' 15K WATERBLAST RUBBER HOSE (CERTIFIED & TESTED) (GDWJ TYPE: 6122054050) (J/S TYPE: 52241-0500505)



60-010-350

3/4" NPTF HAND-ADJUSTABLE SHUT-IN REGULATOR (15K)
INLET (J/S TYPE: 55570)

15K psi FOOT OPERATED DUMP GUN

Assembly No. 61-010-012

Foot Operated Control Valves (Foot Guns) are designed for smooth, reliable operation. They are easily rebuilt in the field in 30 seconds by unscrewing the dump tube, which removes the used valve assembly. The operator then snaps a new cartridge style valve in to the dump tube adapter and returns the whole assembly to the gun.

To prevent low pressure water from the flex lance nozzle spraying back towards the operator, it is recommended that a Nozzle Shut-Off Valve (*Part No. 60-101-050*) is used between the foot gun and the flex lance. This will help minimize cleanup and greatly assist the operator when inserting the lance in to the next tube. Strain Relief Whip Hoses (*Part No. 43-004-003*) are designed to relieve the forces on the flex lance end fitting, which extends the life of the lance and reduces the risk to the operator associated with the end fitting falling prematurely.

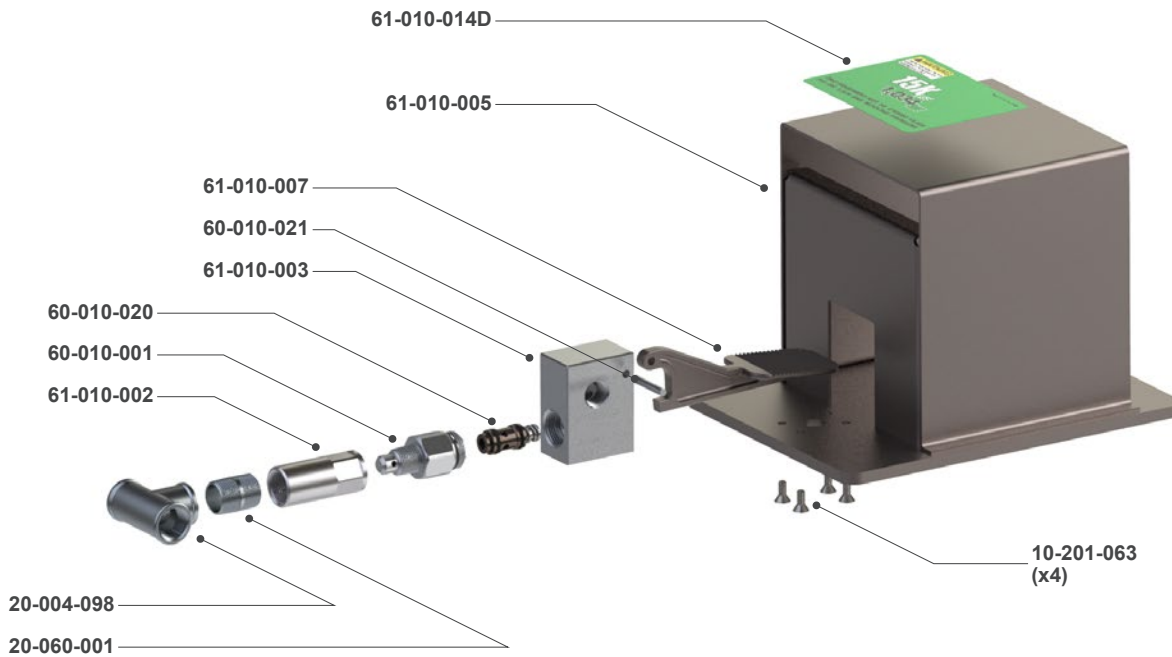

PART NO.	BILL OF MATERIALS (<i>Assembly No. 61-010-012</i>)	QUANTITY
10-201-063	1/4"-20 X 5/8" STAINLESS STEEL FLAT HEAD SOCKET CAP SCREW	4
20-004-098	3/4" NPT 316 STAINLESS STEEL THREADED TEE (150# CLASS)	1
20-060-001	3/4" NPT 316 SCH. 40 CLOSE NIPPLE (150 PSI)	1
60-010-020	15K HAND/FOOT GUN CARTRIDGE ASSEMBLY (J/S TYPE: 50902)	1
60-010-021	GUN TRIGGER PIVOT PIN	1
61-010-001	15K FOOT GUN DUMP ADAPTER	1
61-010-002	FOOT GUN DUMP TUBE	1
61-010-003	15K FOOT GUN BLOCK	1
61-010-005	STANDARD FOOT GUN BASE ASSEMBLY	1
61-010-007	FOOT GUN PEDAL	1
61-010-014D	15K FOOT GUN ASSEMBLY DECAL	1

15K psi FOOT OPERATED DUMP GUN

Assembly No. 61-010-012

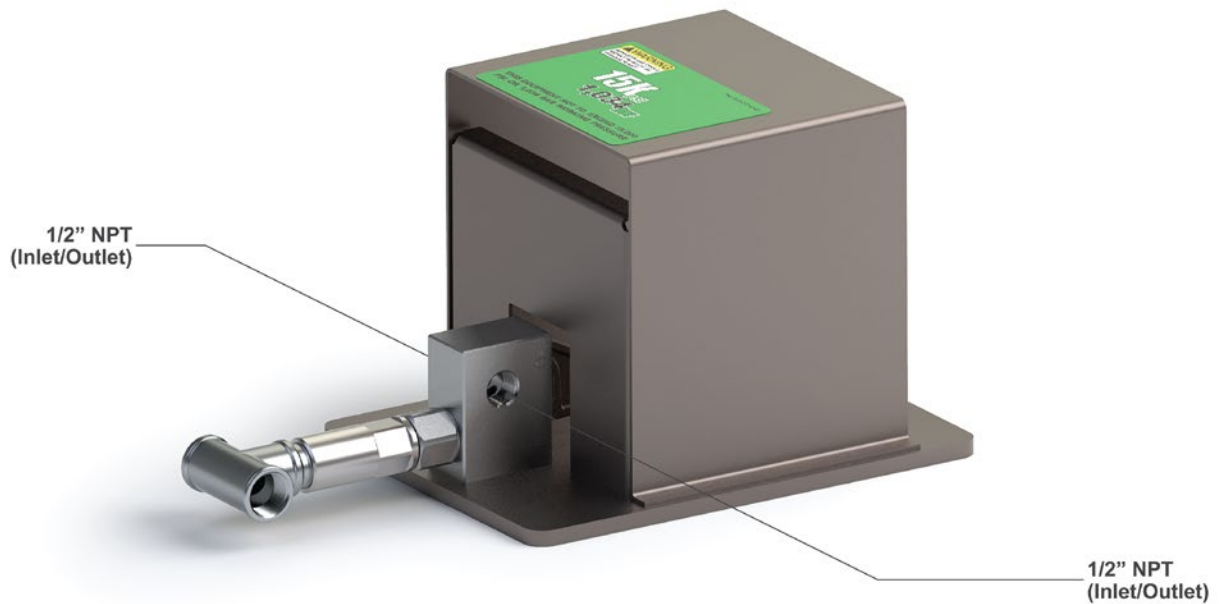

Paired for 15K psi Foot Operated Dump Gun...



20-003-008

1/2" NPT SCREW TYPE COUPLING ASSEMBLY (15K MAWP)
(J/S TYPE: 50989)



20-011-008

1/2" NPTM X 1/2" NPTM HEX NIPPLE (15K MAWP)
(GDWJ TYPE: 3432509) (J/S TYPE: 50488)



43-004-050

1/2" NPT B/E X 50' 15K WATERBLAST RUBBER HOSE (CERTIFIED & TESTED) (GDWJ TYPE: 6122054050) (J/S TYPE: 52241-0500505)



43-010-002

NYLON 1-PLY SAFETY WHIP CHECK W/ RUBBER GROMMET STOPS (APP. 31-1/2" LONG)

20K psi FOOT OPERATED DUMP GUN

Assembly No. 61-020-003

Foot operated control valves (foot guns) are designed for smooth, reliable operation. They are easily rebuilt in the field in 30 seconds by unscrewing the dump tube, which removes the used valve assembly. The operator then snaps a new cartridge style valve in to the dump tube adapter and returns the whole assembly to the gun.

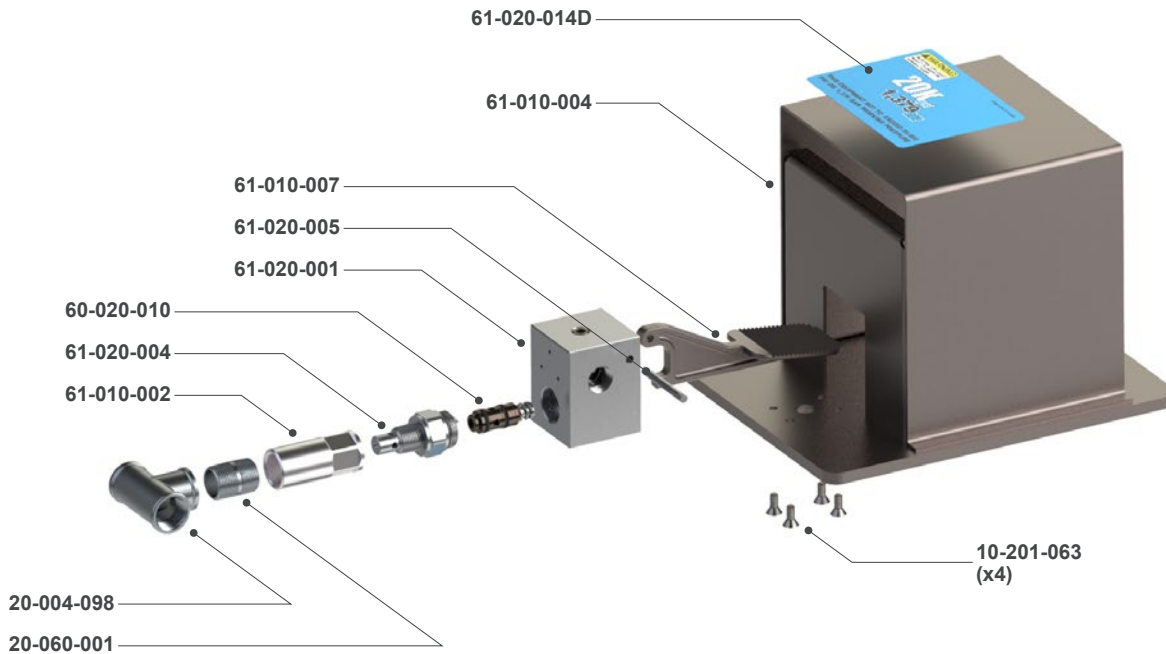

PART NO.	BILL OF MATERIALS (Assembly No. 61-020-003)	QUANTITY
10-201-063	1/4"-20 X 5/8" STAINLESS STEEL FLAT HEAD SOCKET CAP SCREW	3
20-004-098	3/4" NPT 316 STAINLESS STEEL THREADED TEE (150# CLASS)	1
20-060-001	3/4" NPT 316 SCH. 40 CLOSE NIPPLE (150 PSI)	1
60-020-010	20K HAND/FOOT GUN CARTRIDGE ASSEMBLY (J/S TYPE: 51869)	4
61-010-002	FOOT GUN DUMP TUBE	1
61-010-004	STANDARD FOOT GUN BASE ASSEMBLY	1
61-010-007	FOOT GUN PEDAL	1
61-020-001	20K MACHINED FOOT GUN BLOCK W/ PLUG	1
61-020-004	20K FOOT GUN DUMP ADAPTER	1
61-020-005	20/40K FOOT GUN & 15K HIGH FLOW FOOT GUN PIVOT PIN	1
61-020-014D	20K FOOT GUN DECAL	1

20K psi FOOT OPERATED DUMP GUN

Assembly No. 61-020-003

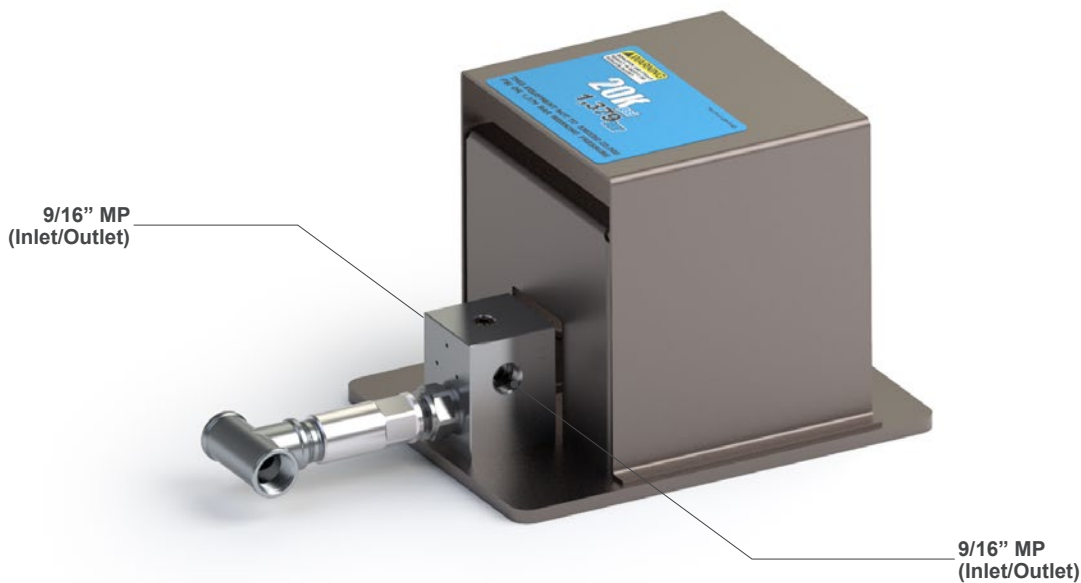

Paired for 20K psi Foot Operated Dump Gun...



21-007-005

9/16" MPM X 13MM (1"-12) TYPE M MALE 20K ADAPTER
(GDWJ TYPE: 77211024)



21-025-001

9/16" MPF SCREW TYPE COUPLING ASSEMBLY
(20K MAWP)

40-015-4343-050C

4113ST X 50' 20.4K 13MM TYPE M STAINLESS STEEL FLEX LANCE
B/E W/ COVER (BLUE) (J/S TYPE: 28347-05042421) (PARKER)



43-010-002

NYLON 1-PLY SAFETY WHIP CHECK W/ RUBBER GROMMET
STOPS (APPROXIMATELY 31-1/2" LONG)

40K psi FOOT OPERATED DUMP GUN

Assembly No. 61-040-003

Foot Operated Control Valves (Foot Guns) are designed for smooth, reliable operation. They are easily rebuilt in the field in 30 seconds by unscrewing the dump tube, which removes the used valve assembly. The operator then snaps a new cartridge style valve in to the dump tube adapter and returns the whole assembly to the gun.

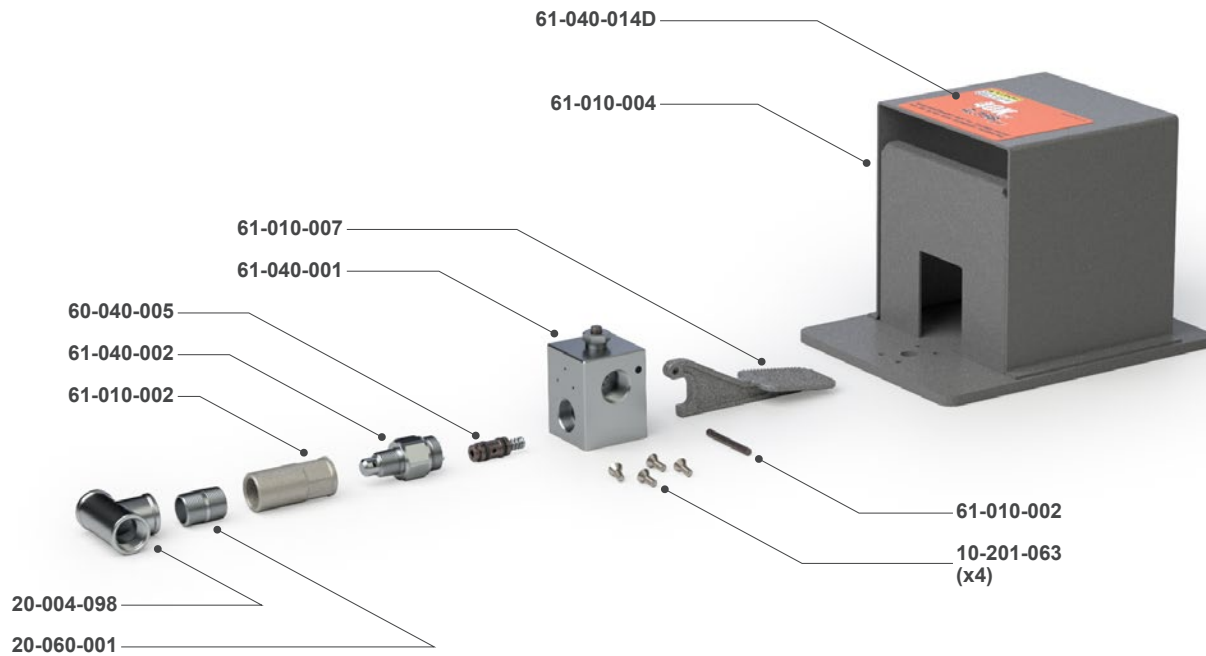

PART NO.	BILL OF MATERIALS (Assembly No. 61-040-003)	QUANTITY
10-201-063	1/4"-20 X 1" LONG STAINLESS STEEL SHCS SCREW	4
20-004-098	3/4" NPT 316 STAINLESS STEEL THREADED TEE (150# CLASS)	1
20-060-001	3/4" NPT 316 SCH. 40 CLOSE NIPPLE (150 PSI)	1
60-040-005	40K HAND/FOOT GUN CARTRIDGE ASSEMBLY (J/S TYPE: 53475)	1
60-070-090	1/4" NPTM BRONZE SINTERRED MUFFLER	1
60-070-091	1/4" NPTM X 1/4" PUSH-LOK 90° PARKER SWIVEL ELBOW (300 MAX PSI)	1
61-010-002	FOOT GUN DUMP TUBE	1
61-010-004	STANDARD FOOT GUN BASE ASSEMBLY	1
61-010-007	FOOT GUN PEDAL	1
61-020-005	20/40K FOOT GUN & 12K HIGH FLOW FOOT GUN PIVOT PIN	1
61-040-001	40K MACHINED FOOT GUN BLOCK ASSEMBLY	1
61-040-002	40K FOOT GUN DUMP ADAPTER ASSEMBLY	1
61-040-014D	40K FOOT GUN DECAL	1

40K psi FOOT OPERATED DUMP GUN

Assembly No. 61-040-003

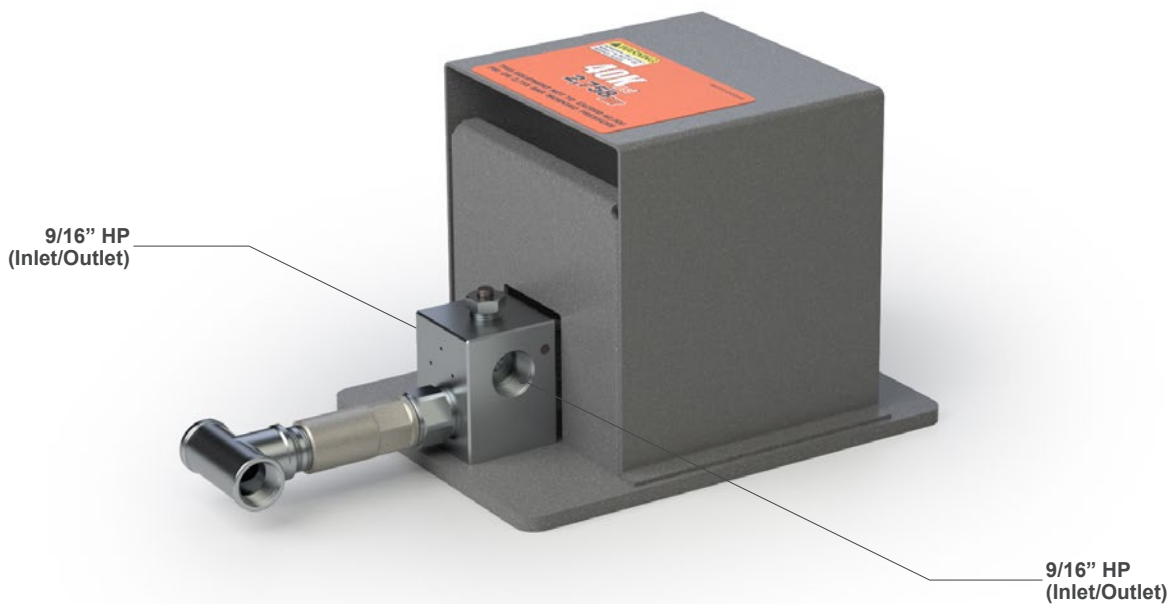

Paired for 40K psi Foot Operated Dump Gun...

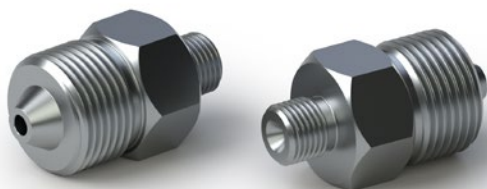

22-012-004

9/16" HPM X 5MM (9/16"-18) TYPE M 40K STAINLESS STEEL ADAPTER (GDWJ TYPE: 77211048)



22-012-006

9/16" HPM X 7/8 (7/8"-14) TYPE M 40K STAINLESS STEEL ADAPTER (GDWJ TYPE: 77211047) (HP9 X M14)



40-024-4242-050C

8108ST X 50' 44K 7/8"-14 SS TYPE M SWIVEL FLEX LANCE B/E W/ PVC COVER (2840D-05V35 - DN8-5/16")



43-010-002

NYLON 1-PLY SAFETY WHIP CHECK W/ RUBBER GROMMET STOPS (APPROXIMATELY 31-1/2" LONG)

15K psi HIGH VOLUME FOOT OPERATED DUMP GUN

Assembly No. 61-050-001

Foot Operated Control Valves (Foot Guns) are designed for smooth and reliable operation. They are easily serviced in the field with a simple 30 second rebuild. Unscrewing the dump tube and cartridge adapter will extract the worn valve assembly. The operator can then snap in a new valve cartridge and reassemble in to the gun block. The Valve is now rebuilt and ready to work.

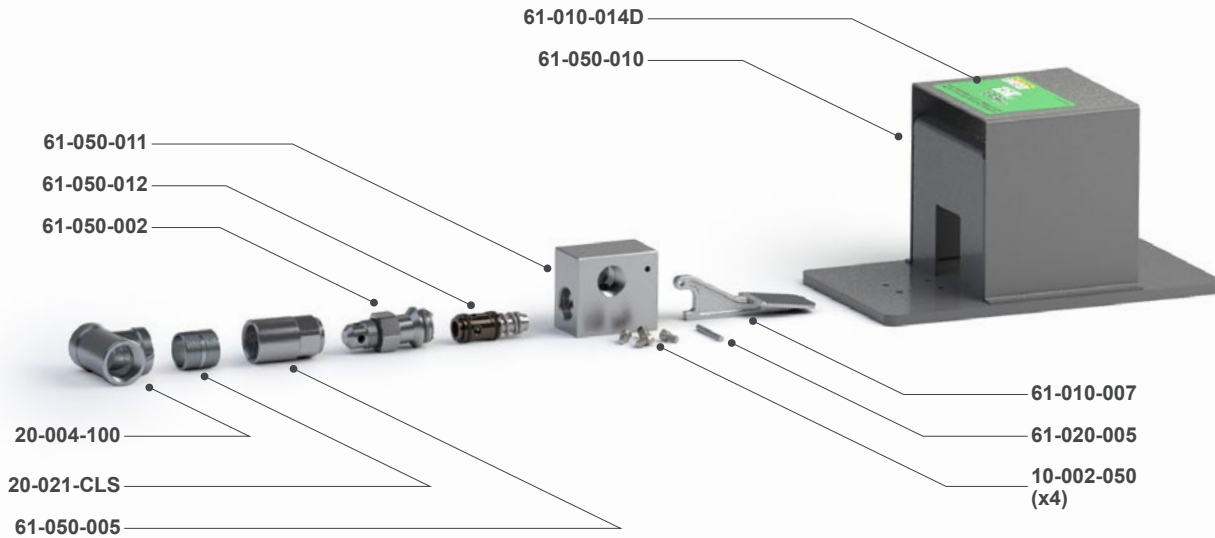

PART NO.	BILL OF MATERIALS (Assembly No. 61-050-001)	QUANTITY
10-002-050	5/16"-18 X 1/2" LONG STAINLESS STEEL SHCS SCREW	4
20-004-100	1-1/4" NPT 316 STAINLESS STEEL THREADED TEE (150# CLASS)	1
20-021-CLS	1-1/4" NPT X CLS (1.625") 304 STAINLESS STEEL NIPPLE	1
61-010-007	FOOT GUN PEDAL	1
61-010-014D	15K HIGH VOLUME FOOT GUN DUMP TUBE ADAPTER	1
61-020-005	20/40K FOOT GUN & 12K HIGH FLOW FOOT GUN PIVOT PIN	1
61-050-002	15K HIGH VOLUME FOOT GUN DUMP TUBE ADAPTER	1
61-050-005	HIGH FLOW FOOT GUN DUMP TUBE	1
61-050-010	HIGH FLOW FOOT GUN BASE ASSEMBLY	1
61-050-011	15K HIGH FLOW FOOT GUN BLOCK	1
61-050-012	15K HIGH FLOW FOOT GUN CARTRIDGE ASSEMBLY	1
61-050-013	15K HIGH VOLUME FOOT GUN DUMP DEFLECTOR ASSEMBLY	1

15K psi HIGH VOLUME FOOT OPERATED DUMP GUN

Assembly No. 61-050-001

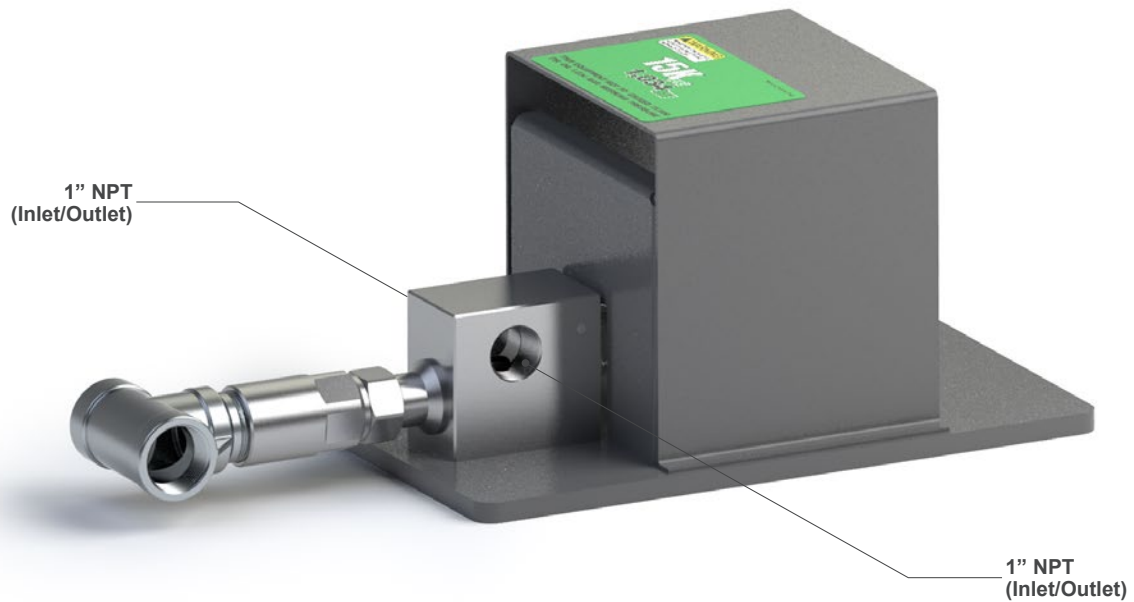

Paired for 15K psi High Volume Foot Operated Dump Gun...



20-003-016

1" NPT SCREW TYPE COUPLING ASSEMBLY
(12K MAWP)



20-011-013

1" NPTM X 1" NPTM HEX NIPPLE
(12K MAWP)



43-008-050

1" NPT B/E X 50' 10K WATERBLAST RUBBER HOSE
(CERTIFIED & TESTED)



43-010-002

NYLON 1-PLY SAFETY WHIP CHECK W/ RUBBER GROMMET
STOPS (APPROXIMATELY 31-1/2" LONG)

20K psi HIGH VOLUME FOOT OPERATED DUMP GUN

Assembly No. 61-020-036

Foot Operated Control Valves (Foot Guns) are designed for smooth and reliable operation. They are easily serviced in the field with a simple 30 second rebuild. Unscrewing the dump tube and cartridge adapter will extract the worn valve assembly. The operator can then snap in a new valve cartridge and reassemble in to the gun block. The Valve is now rebuilt and ready to work.

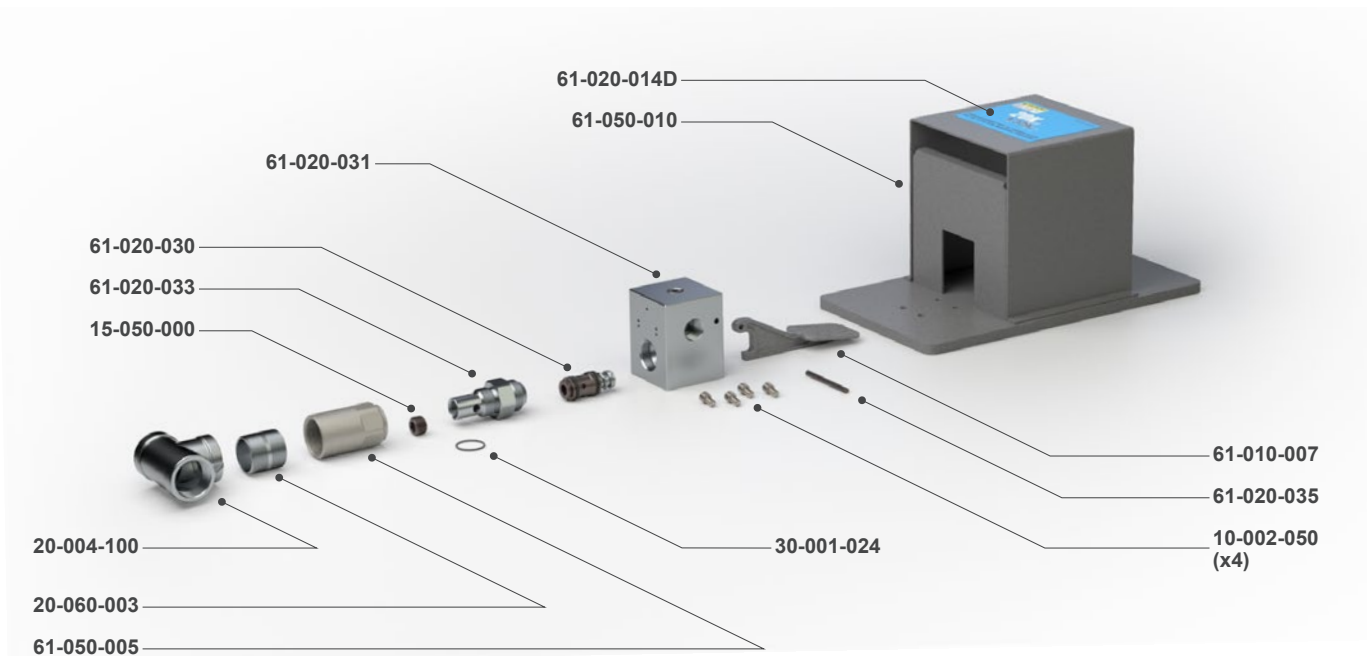

PART NO.	BILL OF MATERIALS (Assembly No. 61-020-036)	QUANTITY
10-002-050	5/16"-18 X 1/2" LONG STAINLESS STEEL SHCS SCREW	4
15-050-000	1/2" NPT 15K STAINLESS STEEL SOCKET HEAD PIPE PLUG	1
20-004-100	1-1/4" NPT 316 STAINLESS STEEL THREADED TEE (150# CLASS)	1
20-060-003	1-1/4" 316 SCH. 40 CLOSE NIPPLE (150 PSI)	1
30-001-024	2-024 BUNA-N 90 DURO O-RING	1
61-010-007	FOOT GUN PEDAL	1
61-020-014D	20K FOOT GUN DECAL	1
61-020-030	15/20K CF H/F MAG CARTRIDGE ASSEMBLY (J/S TYPE: 52750)	1
61-020-031	20K/22K HIGH FLOW MACHINED FOOT GUN BLOCK	1
61-020-033	20K HIGH FLOW FOOT GUN DUMP ADAPTER	1
61-020-035	20K HIGH FLOW FOOT GUN PIVOT PIN	1
61-050-005	1-1/4" NPT 20K HIGH FLOW FOOT GUN DUMP TUBE	1
61-050-010	HIGH FLOW FOOT GUN BASE ASSEMBLY	1

20K psi HIGH VOLUME FOOT OPERATED DUMP GUN

Assembly No. 61-020-036

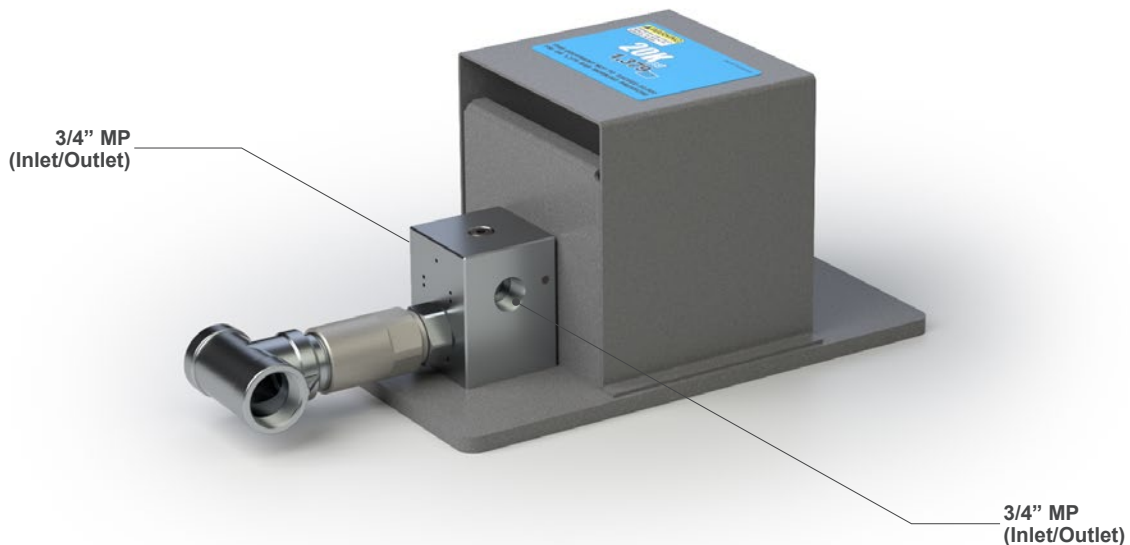

Paired for 20K psi High Volume Foot Operated Dump Gun...



21-007-008
 3/4" MPM X 13MM (1"-12) TYPE M MALE 20K ADAPTER
 (GDWJ TYPE: 77211026 OR AF 063-MP12)

21-025-006
 3/4" MP SCREW TYPE COUPLING ASSEMBLY
 (20K MAWP)

40-015-4343-050C
 4113ST X 50' 20.4K 13MM TYPE M STAINLESS STEEL FLEX LANCE
 B/E W/ COVER (BLUE) (J/S TYPE: 28347-05042421) (PARKER)

XX-XXX-XXX
 INSERT DESCRIPTION HERE
 ...

15K psi HAND-HELD DUMP GUN w/ 3/8" NPT BARREL

Assembly No. 60-010-052

Features:

- The cartridge valve enables the gun to be rebuilt in the field in 30 seconds or less, thus minimizing downtime and increasing productivity
- The cartridge valve also keeps the trigger force to a minimum, reducing operator stress
- These guns are lighter in weight (13-15 lbs depending on the barrel diameter), resulting in less operator fatigue
- The adjustable comfort-contoured shoulder stocks front hand grips contribute to ease of use for operators, tending to diminish fatigue
- These guns come standard with 48" front barrels for operator safety
- All working components are stainless steel for corrosion resistance and durability

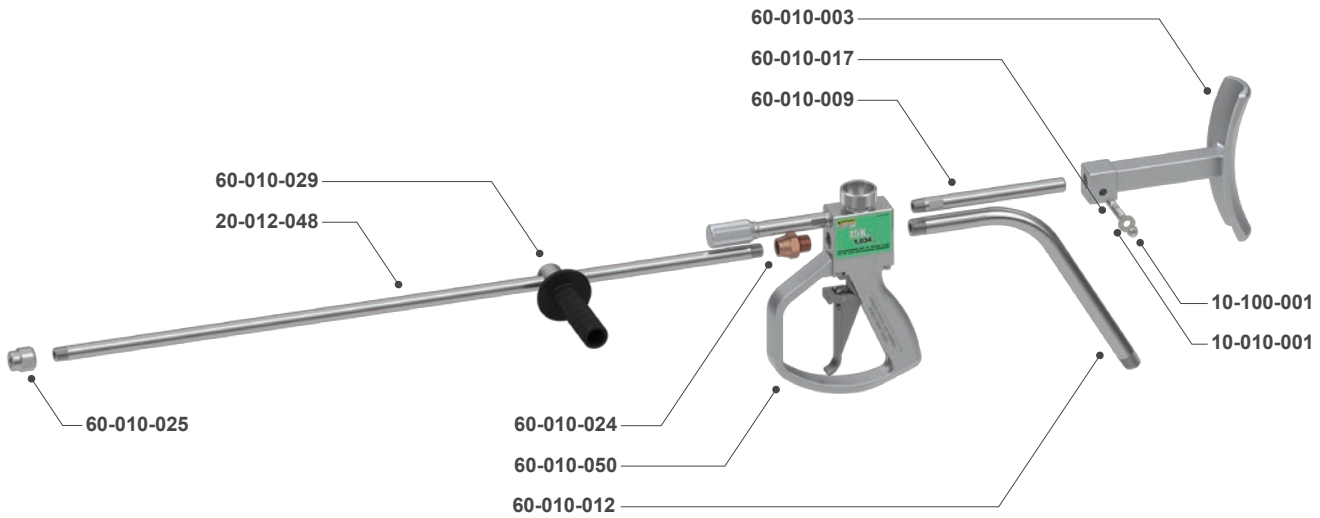

PART NO.	BILL OF MATERIALS (Assembly No. 60-010-052)	QUANTITY
10-010-001	3/8" NPT STAINLESS STEEL FLAT WASHER	1
10-100-001	1/4"-20 STAINLESS STEEL NYLON LOCK NUT	1
20-012-048	3/8" NPT X 48" 15K STAINLESS STEEL NIPPLE	1
60-010-003	3/8" CONTROL GUN SHOULDER STOCK	1
60-010-009	SHOULDER STOCK REAR TUBE	1
61-010-012	1/2" NPT (BENT) 15K HAND GUN INLET TUBE	1
61-010-017	3/8" NPT BARREL GUN SHOULDER STOCK CAM STUD ASSEMBLY	1
61-010-024	1/2" NPTM X 3/8" NPTF GUN BARREL BUSHING W/ NIPPLE SUPPORT RELIEF (GDWJ TYPE: 77700636 OR 31045636)	1
61-010-025	3/8" NPT X 1/4" NPT 15K STAINLESS STEEL NOZZLE HOLDER (GDWJ TYPE: 7770087)	1
61-010-029	3/8" NPT (ADJUSTABLE BARREL) FRONT GUN HANDLE ASSEMBLY	1
61-010-050	1/2" & 3/8" NPT 15K DUMP STYLE HANDLE ASSEMBLY	1

15K psi HAND-HELD DUMP GUN w/ 3/8" NPT BARREL

Assembly No. 60-010-052

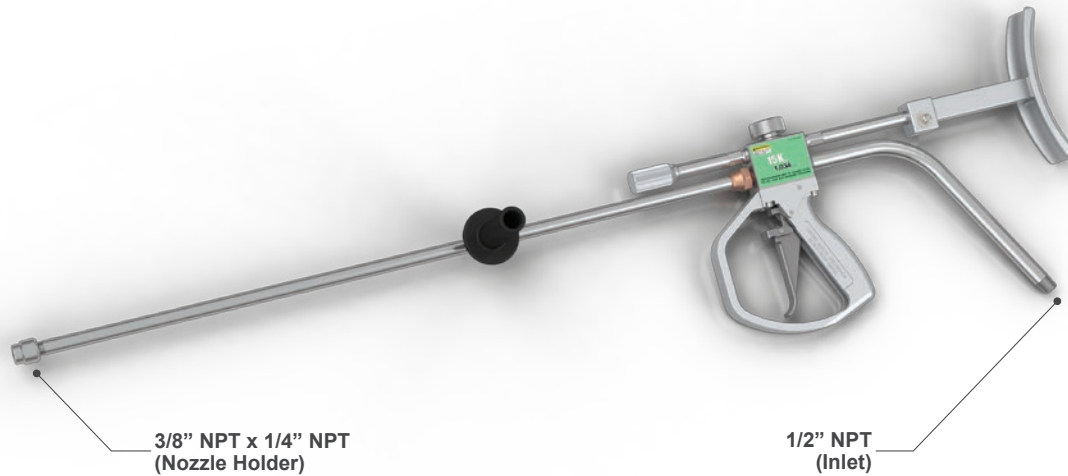

3/8" NPT x 1/4" NPT
(Nozzle Holder)

1/2" NPT
(Inlet)

Paired for 15K psi Hand-Held Dump Gun w/ 3/8" NPT Barrel...

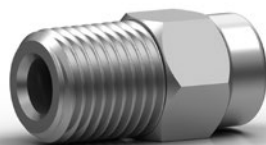

15-021-XXX

1/4" NPT 0.XXX" DIAMETER TUNGSTEN CARBIDE HARD HITTER NOZZLE (#XX)



20-003-008

1/2" NPT (15K MAWP) SCREW TYPE COUPLING ASSEMBLY (J/S TYPE: 50989)



44-020-003

1/2" NPT 15K WHIP HOSE X 6' ASSEMBLY, SAFETY SHROUD & ADAPTER (GDWJ TYPE: 77516032)



60-010-020

15K HAND/FOOT GUN CARTRIDGE ASSEMBLY (J/S TYPE: 50902)

15K psi HAND-HELD DUMP GUN w/ 1/2" NPT BARREL

Assembly No. 60-010-051

Features:

- The cartridge valve enables the gun to be rebuilt in the field in 30 seconds or less, thus minimizing downtime and increasing productivity
- The cartridge valve also keeps the trigger force to a minimum, reducing operator stress
- These guns are lighter in weight (13-15 lbs depending on the barrel diameter), resulting in less operator fatigue
- The adjustable comfort-contoured shoulder stocks front hand grips contribute to ease of use for operators, tending to diminish fatigue
- These guns come standard with 48" front barrels for operator safety
- All working components are stainless steel for corrosion resistance and durability

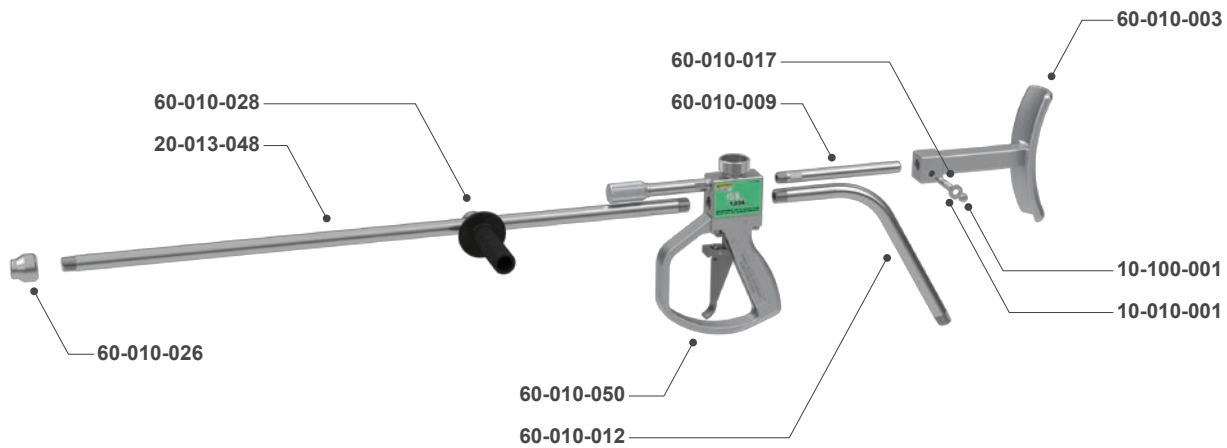

PART NO.	BILL OF MATERIALS (Assembly No. 60-010-051)	QUANTITY
10-001-001	3/8" FLAT STAINLESS STEEL WASHER	1
10-100-001	1/4"-20 STAINLESS STEEL NYLON LOCK NUT	1
20-013-048	1/2" NPT X 48" STAINLESS STEEL 15K NIPPLE (GDWJ TYPE: 77513027)	1
60-010-003	3/8" CONTROL GUN SHOULDER STOCK	1
60-010-009	SHOULDER STOCK REAR TUBE	1
60-010-012	1/2" NPT (BENT) 15K HANDGUN INLET TUBE	1
60-010-017	GUN SHOULDER STOCK CAM STUDY ASSEMBLY (3/8" NPT BARREL)	1
60-010-026	1/2" NPT X 1/4" NPT 15K STAINLESS STEEL NOZZLE HOLDER (GDWJ TYPE: 77513028)	1
60-010-028	GUN FRONT HANDLE ASSEMBLY (1/2" NPT ADJUSTABLE BARREL)	1
60-010-050	1/2" & 3/8" NPT DUMP STYLE 15K HANDLE ASSEMBLY	1

15K psi HAND-HELD DUMP GUN w/ 1/2" NPT BARREL

Assembly No. 60-010-051

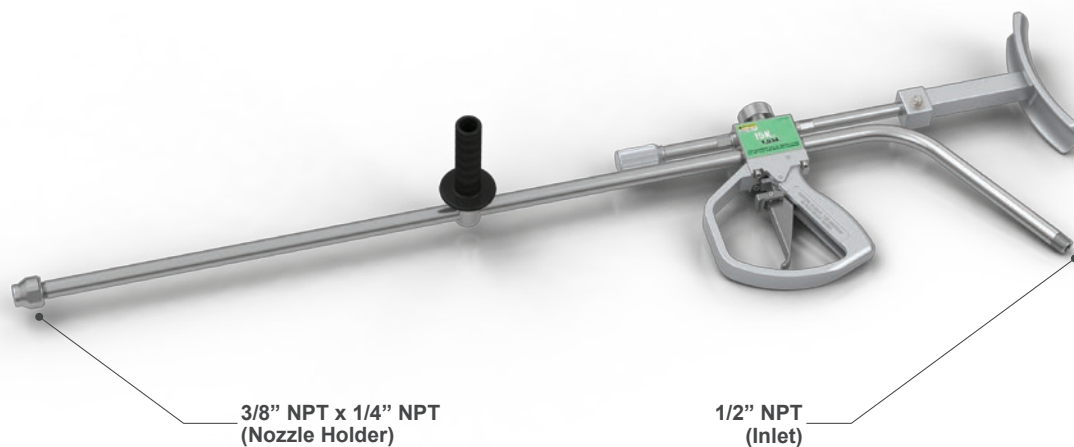

Paired for 15K psi Hand-Held Dump Gun w/ 1/2" NPT Barrel...



15-021-XXX

1/4" NPT 0.125" DIAMETER TUNGSTEN CARBIDE HARD HITTER NOZZLE (#XX)



20-003-008

1/2" NPT (15K MAWP) SCREW TYPE COUPLING ASSEMBLY (J/S TYPE: 50989)



44-020-003

1/2" NPT 15K WHIP HOSE X 6' ASSEMBLY, SAFETY SHROUD & ADAPTER (GDWJ TYPE: 77516032)



60-010-020

15K HAND/FOOT GUN CARTRIDGE ASSEMBLY (J/S TYPE: 50902)

20K psi HAND-HELD DUMP GUN w/ 9/16" MP BARREL

Assembly No. 60-020-006

These guns are the new standard and are built tough for the demands of today's contracting environment.

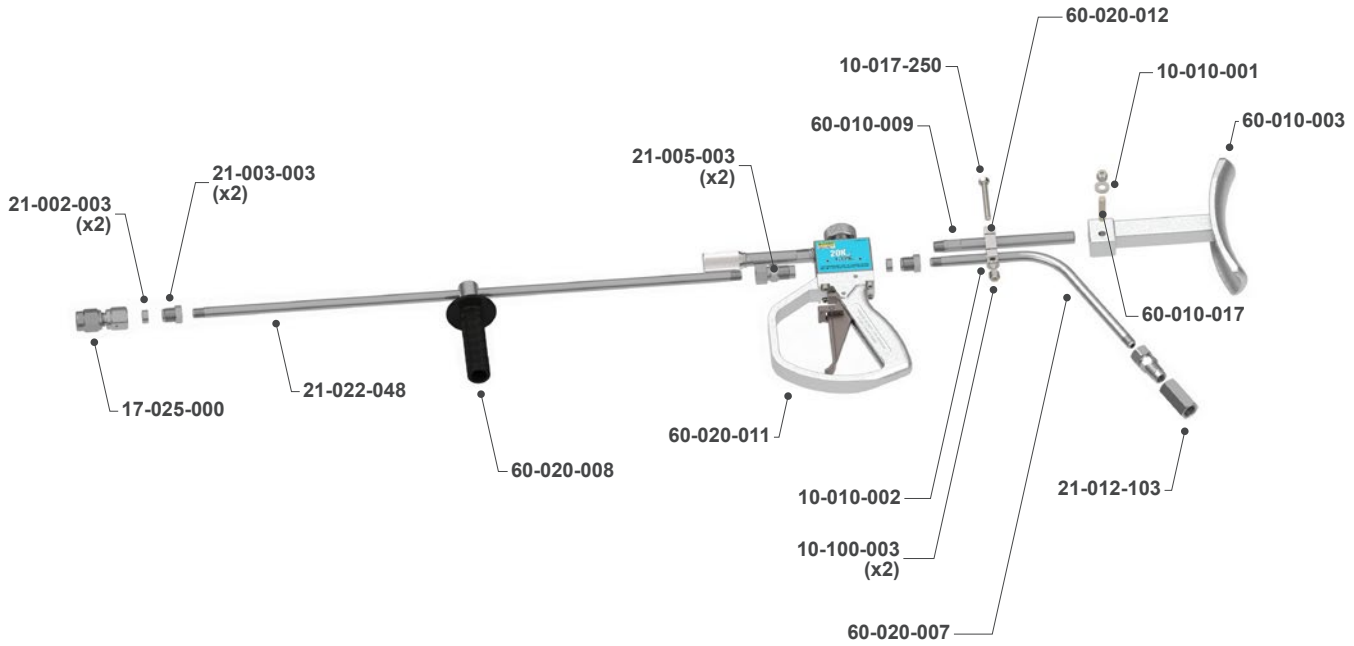

PART NO.	BILL OF MATERIALS (Assembly No. 60-020-006)	QUANTITY
10-010-001	3/8" FLAT STAINLESS STEEL WASHER	4
10-010-002	5/16" FLAT STAINLESS STEEL WASHER	4
10-017-250	5/16"-18 X 2-1/2" STAINLESS STEEL HEX HEAD BOLT	1
10-100-003	5/16"-18 STAINLESS STEEL NYLON LOCK NUT	1
17-025-000	9/16" MP 20K DROP-IN NOZZLE HOLDER ASSEMBLY W/O GLAND NUT & COLLAR	1
21-002-003	9/16" MP 20K COLLAR (AF 071-MP9)	1
21-003-003	9/16" MP 20K GLAND NUT (AF 070-MP9)	1
21-005-003	9/16" MP ANTI-VIBE COLLET ASSEMBLY W/ COLLAR	1
21-012-103	9/16" MP 20K COUPLER W/O GLAND NUT & COLLAR	1
21-022-048	9/16" MP/LH X 48" 20K MAWP STAINLESS STEEL NIPPLE (GDWJ TYPE: 77513056)	1
60-010-003	3/8" SHOULDER STOCK CONTROL GUN	1
60-010-009	SHOULDER STOCK REAR TUBE	1
60-010-017	GUN SHOULDER STOCK CAM STUD ASSEMBLY (3/8" NPT BARREL)	1
60-020-007	9/16" MP (BENT) 20K HAND GUN INLET TUBE	1
60-020-008	9/16" 20/40K FRONT GUN HANDLE ASSEMBLY (ADJUSTABLE BARREL)	1
60-020-011	9/16" 20K MP DUMP STYLE HANDLE ASSEMBLY	1
60-020-012	GUN INLET TUBE CLAMP (NEW)	1

20K psi HAND-HELD DUMP GUN w/ 9/16" MP BARREL

Assembly No. 60-020-006



Paired for 20K psi Hand-Held Dump Gun w/ 9/16" MP Barrel...	
 <p>21-002-003 9/16" MEDIUM PRESSURE 20K COLLAR (AF 071-MP9)</p>	 <p>21-003-003 9/16" MEDIUM PRESSURE 20K GLAND NUT (AF 070-MP9)</p>
 <p>60-020-010 20K HAND/FOOT GUN CARTRIDGE ASSEMBLY (J/S TYPE: 51869)</p>	<p>XX-XXX-XXX INSERT DESCRIPTION HERE ...</p>

40K psi HAND-HELD DUMP GUN w/ NOZZLE HOLDER

Assembly No. 60-040-007

These guns are the new standard and are built tough for the demands of today's contracting environment.

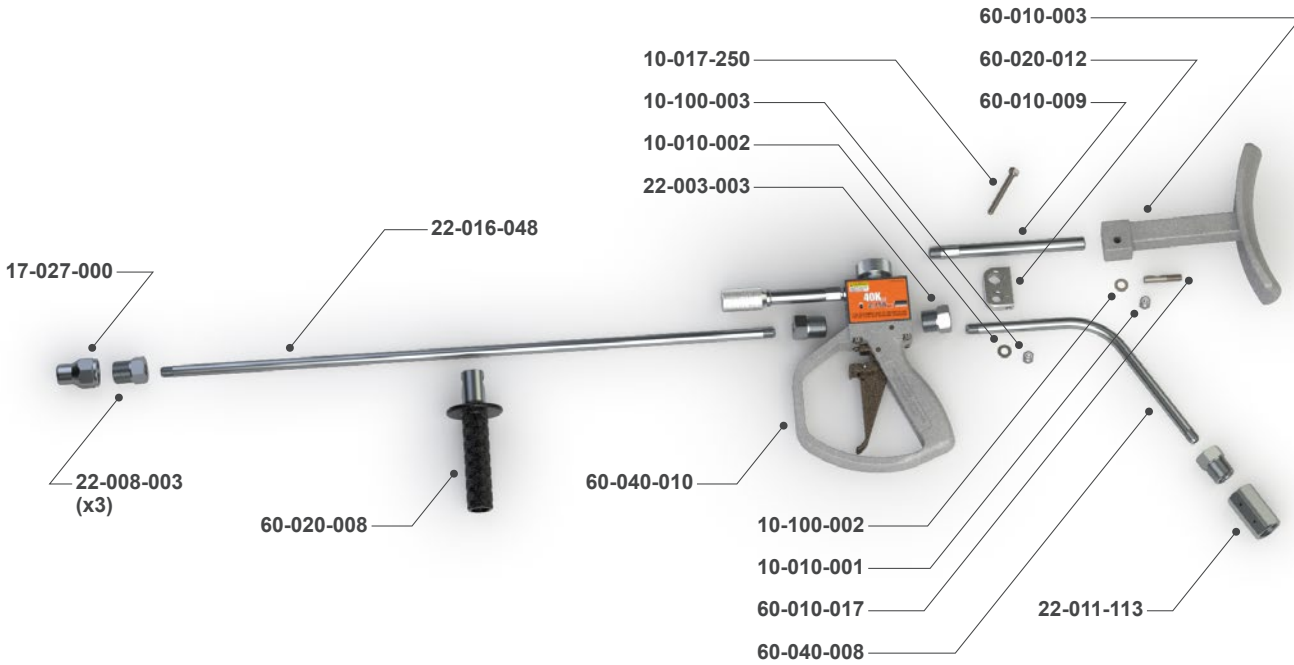

PART NO.	BILL OF MATERIALS (Assembly No. 60-040-007)	QUANTITY
10-010-001	3/8" FLAT STAINLESS STEEL WASHER	1
10-010-002	5/16" FLAT STAINLESS STEEL WASHER	1
10-017-250	5/16"-18 X 2-1/2" STAINLESS STEEL HEX HEAD BOLT	1
10-100-002	3/8"-16 STAINLESS STEEL NYLON LOCK NUT	1
10-100-003	5/16"-18 STAINLESS STEEL NYLON LOCK NUT	1
17-027-000	9/16" HPF (1-1/8"-12) X 3/8"-24 UNF 40K NOZZLE HOLDER (F/40K DUMP GUN)	1
22-002-003	9/16" HP 60K COLLAR (AF 071-H9) (GDWJ TYPE: 3610012)	1
22-003-003	9/16" HP 60K GLAND NUT (AF 070-H9)	1
22-008-003	9/16" HP ANTI-VIBE COLLET ASSEMBLY (GLAND NUT, SPLIT COLLET & COLLAR) (J/S TYPE: 28090)	3
22-011-113	9/16" HP 40K COUPLER W/O GLAND NUT & COLLAR (O.D. TURNED DOWN TO 1.480" DIAMETER)	1
22-016-048	9/16" HP/LH X 48" 60K MAWP NIPPLE	1
60-010-003	3/8" CONTROL GUN SHOULDER STOCK	1
60-010-009	SHOULDER STOCK REAR TUBE	1
60-010-017	GUN SHOULDER STOCK CAM STUD ASSEMBLY (3/8" NPT BARREL)	1
60-020-008	9/16" 20/40K FRONT GUN HANDLE ASSEMBLY (ADJUSTABLE BARREL)	1
60-020-012	GUN INLET TUBE CLAMP (NEW)	1
60-040-008	9/16" HP (BENT) 40K HAND GUN INLET TUBE	1
60-040-010	9/16" HP 40K HAND GUN HANDLE ASSEMBLY	1

40K psi HAND-HELD DUMP GUN w/ NOZZLE HOLDER

Assembly No. 60-040-007



Paired for 40K psi Hand-Held Dump Gun w/ Nozzle Holder...

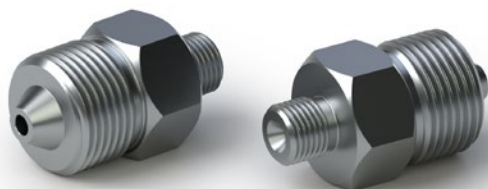

22-012-004

9/16" HPM X 5MM (9/16"-18) TYPE M 40K STAINLESS STEEL ADAPTER (GDWJ TYPE: 77211048)

44-021-031

40K X 6' SAFETY SHROUD, ADAPTER & WHIP HOSE ASSEMBLY (6105ST X 5MM TYPE M X 6')

15K psi HAND-HELD DOUBLE DUMP GUN

Assembly No. 60-050-006

There is an increasing demand for the extra safety of control guns - which incorporate dual dump ports. Our Double Dump Control Guns feature ergonomic advantages and a specially designed front handle. The handle itself is at a 90° angle to the barrel, conforming to the operator's hand and arm. Some other guns simply use two standard handles, which are cumbersome, uncomfortable, too heavy, and difficult to use.

Double Dump Guns are available in 3/8" barrel size.

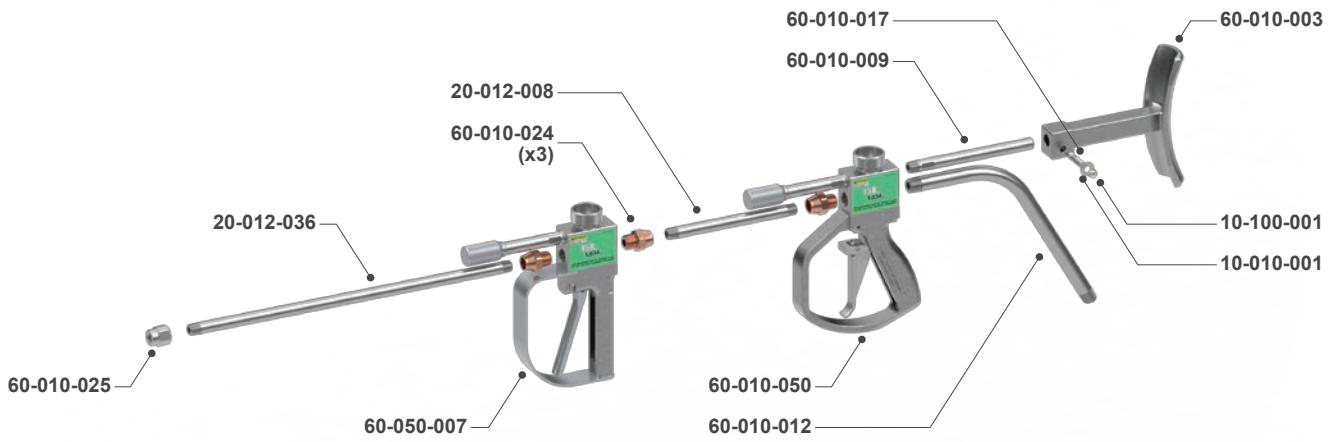

PART NO.	BILL OF MATERIALS (Assembly No. 60-050-006)	QUANTITY
10-010-001	3/8" FLAT STAINLESS STEEL WASHER	1
10-100-001	1/4"-20 STAINLESS STEEL NYLON LOCK NUT	1
20-012-008	3/8" NPT X 8" 15K STAINLESS STEEL NIPPLE	1
20-012-036	3/8" NPT BARREL (36" LONG)	1
60-010-003	3/8" CONTROL GUN SHOULDER STOCK	1
60-010-009	SHOULDER STOCK REAR TUBE	1
60-010-012	1/2" NPT (BENT) 15K HANDGUN INLET TUBE	1
60-010-017	GUN SHOULDER STOCK CAM STUD ASSEMBLY (3/8" NPT BARREL)	1
60-010-024	1/2" NPTM X 3/8" NPTF GUN BARREL BUSHING W/ NIPPLE SUPPORT RELIEF (GDWJ TYPE: 77700636 OR 31045636)	3
60-010-025	3/8" NPT X 1/4" NPT 15K STAINLESS STEEL NOZZLE HOLDER (GDWJ TYPE: 7770087)	1
60-010-050	1/2" & 3/8" NPT 15K DUMP STYLE HANDLE ASSEMBLY	1
60-050-007	1/2" NPT 15K FRONT DOUBLE DUMP HANDLE ASSEMBLY	1

15K PSI HAND-HELD DOUBLE DUMP GUN

Assembly No. 60-050-006

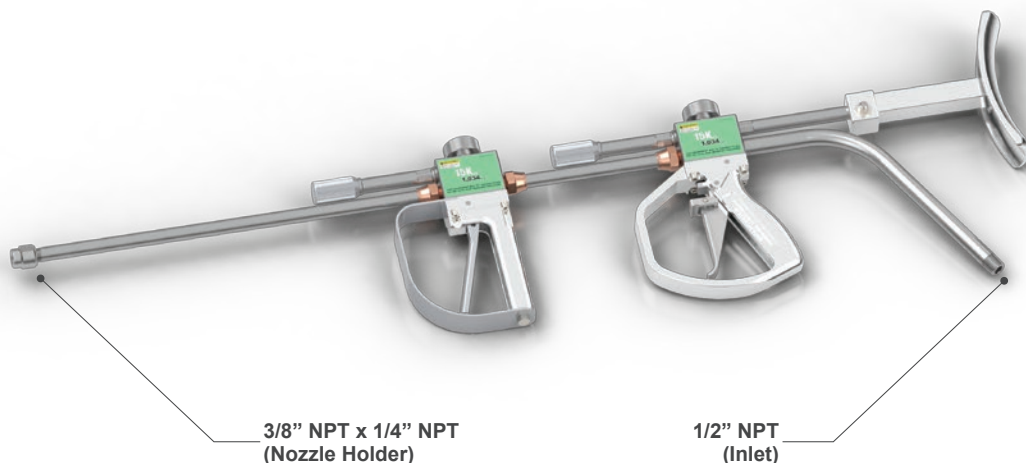

3/8" NPT x 1/4" NPT
(Nozzle Holder)

1/2" NPT
(Inlet)

Paired for 15K psi Hand-Held Double Dump Gun...



15-021-XXX

1/4" NPT 0.XXX" DIAMETER TUNGSTEN CARBIDE HARD HITTER NOZZLE (#XX)



20-003-008

1/2" NPT (15K MAWP) SCREW TYPE COUPLING ASSEMBLY (J/S TYPE: 50989)



44-020-003

1/2" NPT 15K WHIP HOSE X 6' ASSEMBLY, SAFETY SHROUD & ADAPTER (GDWJ TYPE: 77516032)



60-010-020

15K HAND/FOOT GUN CARTRIDGE ASSEMBLY (J/S TYPE: 50902)

20K psi HAND-HELD DOUBLE DUMP GUN

Assembly No. 60-055-001

Our 20K Double Dump Control Gun features ergonomic advantages and a specially designed front handle, set at a 90-degree angle to the barrel, thus conforming to the operator's hand and arm. Some other guns simply use two standard handles, which are cumbersome, uncomfortable, too heavy, and difficult to use.

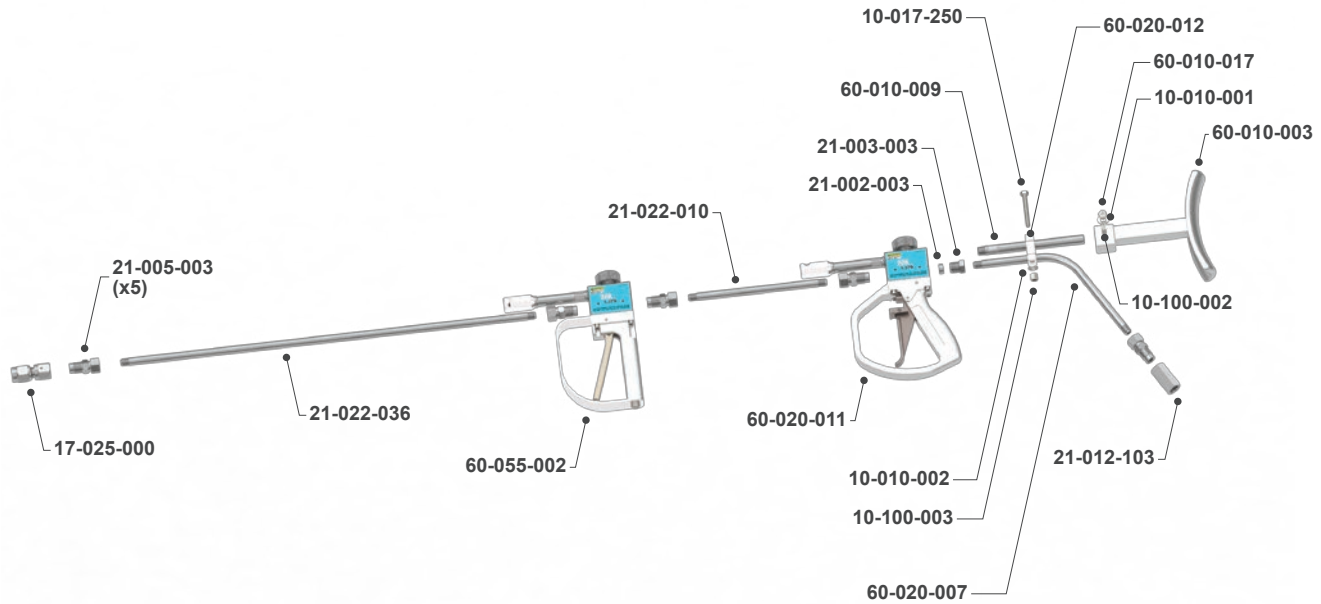

PART NO.	BILL OF MATERIALS (Assembly No. 60-055-001)	QUANTITY
10-010-001	3/8" FLAT STAINLESS STEEL WASHER	4
10-010-002	5/16" FLAT STAINLESS STEEL WASHER	4
10-017-250	5/16"-18 X 2-1/2" STAINLESS STEEL HEX HEAD BOLT	1
10-100-002	3/8"-16 STAINLESS STEEL NYLON LOCK NUT	1
10-100-003	5/16"-18 STAINLESS STEEL NYLON LOCK NUT	1
17-025-000	9/16" MP 20K DROP-IN NOZZLE HOLDER ASSEMBLY W/O GLAND NUT & COLLAR	1
21-002-003	9/16" MP 20K COLLAR (AF 071-MP9)	1
21-003-003	9/16" MP 20K GLAND NUT (AF 070-MP9)	1
21-005-003	9/16" MP ANTI-VIBE COLLET ASSEMBLY W/ COLLAR	1
21-012-103	9/16" MP 20K COUPLER W/O GLAND NUT & COLLAR	1
21-022-010	9/16" MP/LH X 10" (20K MAWP) STAINLESS STEEL NIPPLE	1
21-022-036	9/16" MP/LH X 36" (20K MAWP) STAINLESS STEEL NIPPLE	1
60-010-003	3/8" SHOULDER STOCK CONTROL GUN	1
60-010-009	SHOULDER STOCK REAR TUBE	1
60-010-017	GUN SHOULDER STOCK CAM STUD ASSEMBLY (3/8" NPT BARREL)	1
60-020-007	9/16" MP (BENT) 20K HAND GUN INLET TUBE	1
60-020-011	9/16" 20K MP DUMP STYLE HANDLE ASSEMBLY	1
60-020-012	GUN INLET TUBE CLAMP (NEW)	1
60-055-002	9/16" MP 20K FRONT DOUBLE DUMP HANDLE ASSEMBLY	1

20K psi HAND-HELD DOUBLE DUMP GUN

Assembly No. 60-055-001

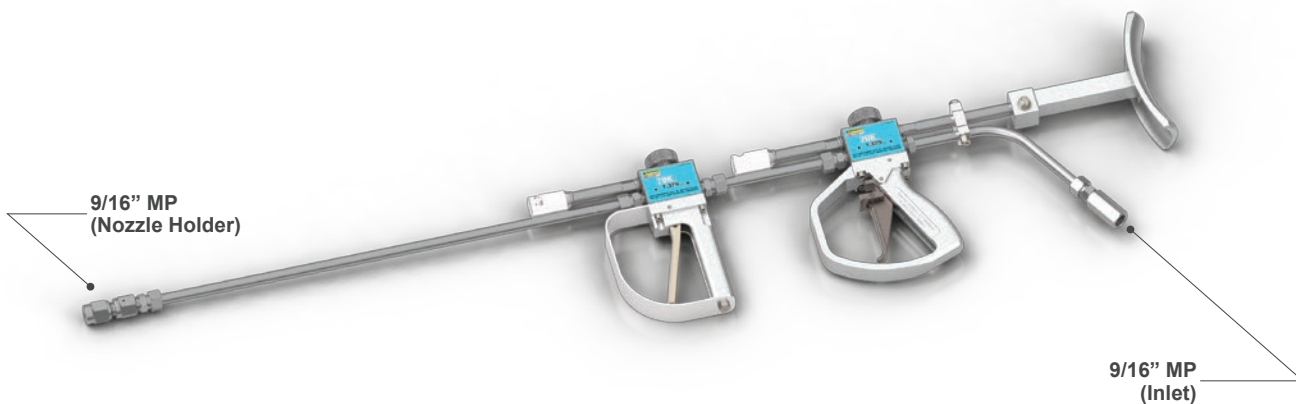

Paired for 20K psi Hand-Held Double Dump Gun...	
 <p>21-002-003 9/16" MEDIUM PRESSURE 20K COLLAR (AF 071-MP9)</p>	 <p>21-003-003 9/16" MEDIUM PRESSURE 20K GLAND NUT (AF 070-MP9)</p>
 <p>60-020-010 20K HAND/FOOT GUN CARTRIDGE ASSEMBLY (J/S TYPE: 51869)</p>	<p>XX-XXX-XXX INSERT DESCRIPTION HERE ...</p>

40K psi HAND-HELD DOUBLE DUMP GUN

Assembly No. 60-040-015

There is an increasing demand for the extra safety of control guns - which incorporate dual dump ports. Our Double Dump Style Control Guns feature ergonomic advantages and a specially designed front handle. The handle itself is at a 90° angle to the barrel, conforming to the operator's hand and arm. Some other guns simply use two standard handles, which are cumbersome, uncomfortable, too heavy, and difficult to use.

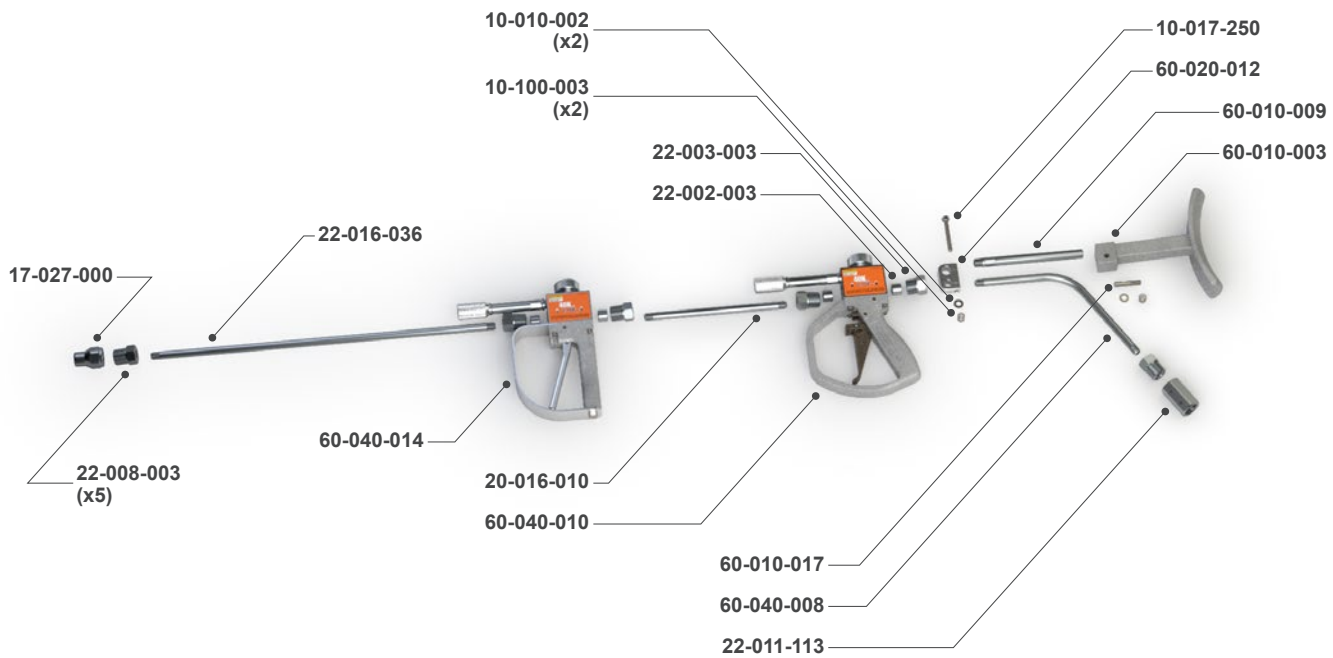

PART NO.	BILL OF MATERIALS (Assembly No. 60-040-015)	QUANTITY
10-010-002	5/16" FLAT STAINLESS STEEL WASHER	2
10-017-250	5/16"-18 X 2-1/2" STAINLESS STEEL HEX HEAD BOLT	1
10-100-003	5/16"-18 STAINLESS STEEL NYLON LOCK NUT	2
17-027-000	9/16" HPF (1-1/8"-12) X 3/8"-24 UNF 40K NOZZLE HOLDER (F/40K DUMP GUN)	1
22-002-003	9/16" HP 60K COLLAR (AF 071-H9) (GDWJ TYPE: 3610012)	1
22-003-003	9/16" HP 60K GLAND NUT (AF 070-H9)	1
22-008-003	9/16" HP ANTI-VIBE COLLET ASSEMBLY (GLAND NUT, SPLIT COLLET & COLLAR) (J/S TYPE: 28090)	5
22-011-113	9/16" HP 40K COUPLER W/O GLAND NUT & COLLAR (O.D. TURNED DOWN TO 1.480" DIAMETER)	1
22-016-010	9/16" HP/LH X 10" 60K MAWP NIPPLE	1
22-016-036	9/16" HP/LH X 36" 60K MAWP NIPPLE	1
60-010-003	3/8" CONTROL GUN SHOULDER STOCK	1
60-010-009	SHOULDER STOCK REAR TUBE	1
60-010-017	GUN SHOULDER STOCK CAM STUD ASSEMBLY (3/8" NPT BARREL)	1
60-020-012	GUN INLET TUBE CLAMP (NEW)	1
60-040-008	9/16" HP (BENT) 40K HAND GUN INLET TUBE	1
60-040-010	9/16" HP 40K HAND GUN HANDLE ASSEMBLY	1
60-040-014	9/16" HP 40K FRONT DOUBLE DUMP HANDLE ASSEMBLY	1

40K psi HAND-HELD DOUBLE DUMP GUN

Assembly No. 60-040-015



Paired for 40K psi Hand-Held Double Dump Gun...

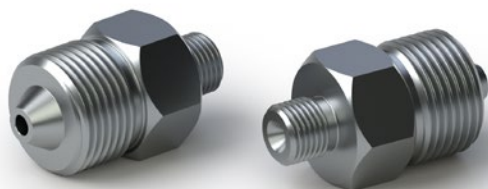

22-012-004

9/16" HPM X 5MM (9/16"-18) TYPE M 40K STAINLESS STEEL
ADAPTER (GDWJ TYPE: 77211048)

44-021-031

40K X 6' SAFETY SHROUD, ADAPTER & WHIP HOSE ASSEMBLY
(6105ST X 5MM TYPE M X 6')

15K psi HAND-HELD ZERO THRUST GUN

Assembly No. 60-010-035

Zero Thrust Style Control Guns are designed primarily for underwater use, where the self-canceling forwards and backwards thrusts allow the operator to carry out blasting operations without being propelled away from the intended work area.

Zero Thrust Style Control Guns also have application on dry land, where a balanced tool is needed, such as in a suspended gondola on the side of a building.

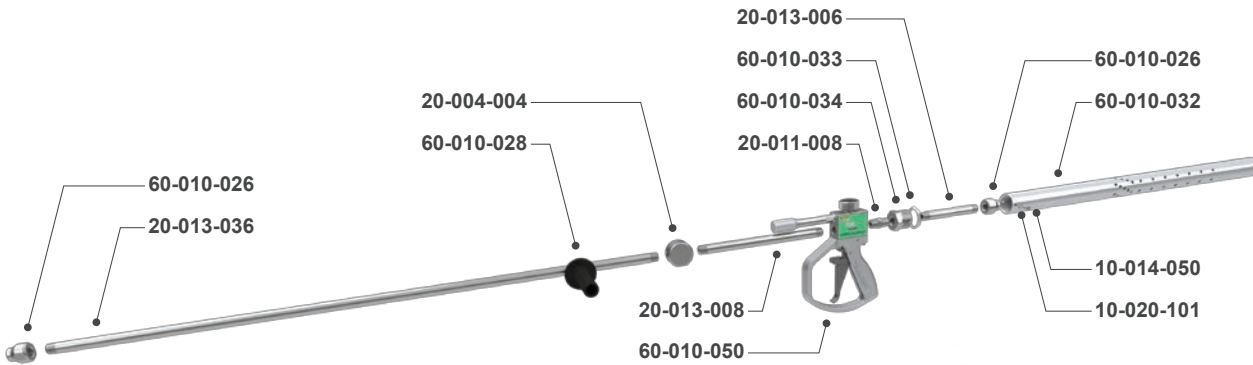

PART NO.	BILL OF MATERIALS (Assembly No. 60-010-035)	QUANTITY
10-014-050	1/4"-20 X 1/2" STAINLESS STEEL HEX HEAD BOLT	1
10-020-101	1/4" STAINLESS STEEL EXTERNAL TOOTH LOCK WASHER	1
20-004-004	1/2" NPT (15K MAWP) WAFER TEE	1
20-011-008	1/2" NPTM X 1/2" NPTM (15K MAWP) HEX NIPPLE	1
20-013-006	1/2" NPT X 6" 15K STAINLESS STEEL NIPPLE	1
20-013-008	1/2" NPT X 8" 15K STAINLESS STEEL NIPPLE	1
20-013-036	1/2" NPT X 36" 15K STAINLESS STEEL NIPPLE	1
60-010-026	1/2" NPT X 1/4" NPT 15K STAINLESS STEEL NOZZLE HOLDER (GDWJ TYPE: 77513028)	2
60-010-028	GUN FRONT HANDLE ASSEMBLY (1/2" NPT ADJUSTABLE BARREL)	1
60-010-032	ZERO THRUST GUN DIFFUSER	1
60-010-033	1-3/4"-12 ZERO THRUST GUN JAM NUT	1
60-010-034	15K STAINLESS STEEL ZERO THRUST ADAPTER	1
60-010-050	1/2" & 3/8" NPT 15K DUMP STYLE HANDLE ASSEMBLY	1

15K psi HAND-HELD ZERO THRUST GUN

Assembly No. 60-010-035

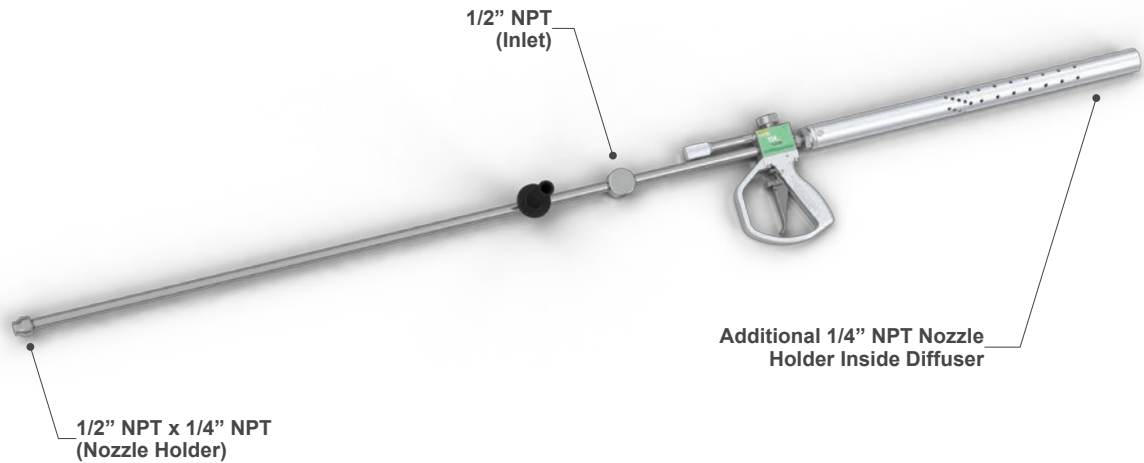

Paired for 15K psi Hand-Held Zero Thrust Gun...



15-021-XXX

1/4" NPT 0.XXX" DIAMETER TUNGSTEN CARBIDE HARD HITTER NOZZLE (#XX)



20-003-008

1/2" NPT (15K MAWP) SCREW TYPE COUPLING ASSEMBLY (J/S TYPE: 50989)



44-020-003

1/2" NPT 15K WHIP HOSE X 6' ASSEMBLY, SAFETY SHROUD & ADAPTER (GDWJ TYPE: 77516032)



60-010-020

15K HAND/FOOT GUN CARTRIDGE ASSEMBLY (J/S TYPE: 50902)

20K psi HAND-HELD ZERO THRUST GUN

Assembly No. 60-020-013

Zero Thrust Style Control Guns are designed primarily for underwater use, where the self-canceling forwards and backwards thrusts allow the operator to carry out blasting operations without being propelled away from the intended work area. They also have application on dry land, where a balanced tool is needed, such as in a suspended gondola on the side of a building.

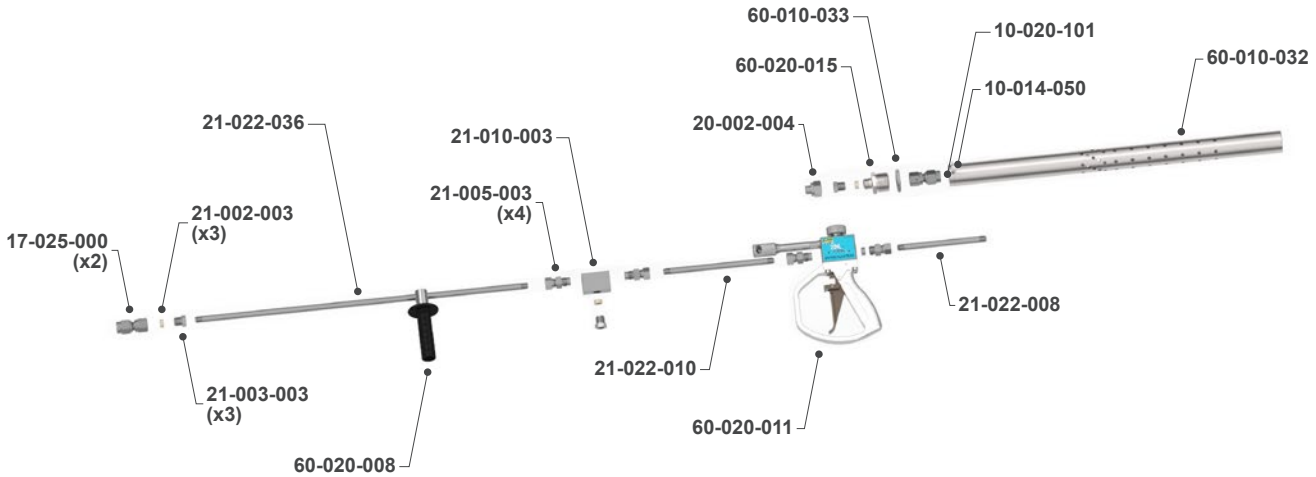

PART NO.	BILL OF MATERIALS (Assembly No. 60-020-013)	QUANTITY
10-014-050	1/4"-20 X 1/2" STAINLESS STEEL HEX HEAD BOLT	4
10-020-101	1/4" STAINLESS STEEL EXTERNAL TOOTH LOCK WASHER	4
17-025-000	9/16" 20K MP DROP-IN NOZZLE HOLDER ASSEMBLY W/O GLAND NUT & COLLAR	1
20-002-004	15/20K RIGID LANCE HOLDER COLLET NUT (DA) (GP 076)	1
20-022-010	0.562" I.D. F/ 9/16" MP RIGID LANCE HOLDER COLLET (100DA) (GP 075-562)	1
21-002-003	9/16" MP 20K COLLAR (AF 071-MP9)	1
21-003-003	9/16" MP 20K GLAND NUT (AF 070-MP9)	1
21-005-003	9/16" MP ANTI-VIBE COLLET ASSEMBLY W/ COLLAR	1
21-010-003	9/16" MP 20K TEE	1
21-022-008	9/16" MP/LH X 8" (20K MAWP) STAINLESS STEEL NIPPLE	1
21-022-010	9/16" (20K MAWP) MP/LH X 10" STAINLESS STEEL NIPPLE	1
21-022-036	9/16" (20K MAWP) MP/LH X 36" STAINLESS STEEL NIPPLE	1
60-010-032	ZERO THRUST GUN DIFFUSER (GDWJ TYPE: 77700058)	1
60-010-033	1-3/4"-12 ZERO THRUST GUN JAM NUT (GDWJ TYPE: 77700157)	1
60-020-008	9/16" 20/40K FRONT GUN HANDLE ASSEMBLY (ADJUSTABLE BARREL)	1
60-020-011	9/16" 20K MP DUMP STYLE HANDLE ASSEMBLY	1
60-020-015	20/40K STAINLESS STEEL ZERO THRUST ADAPTER (GDWJ TYPE: 77700158)	1

20K psi HAND-HELD ZERO THRUST GUN

Assembly No. 60-020-013

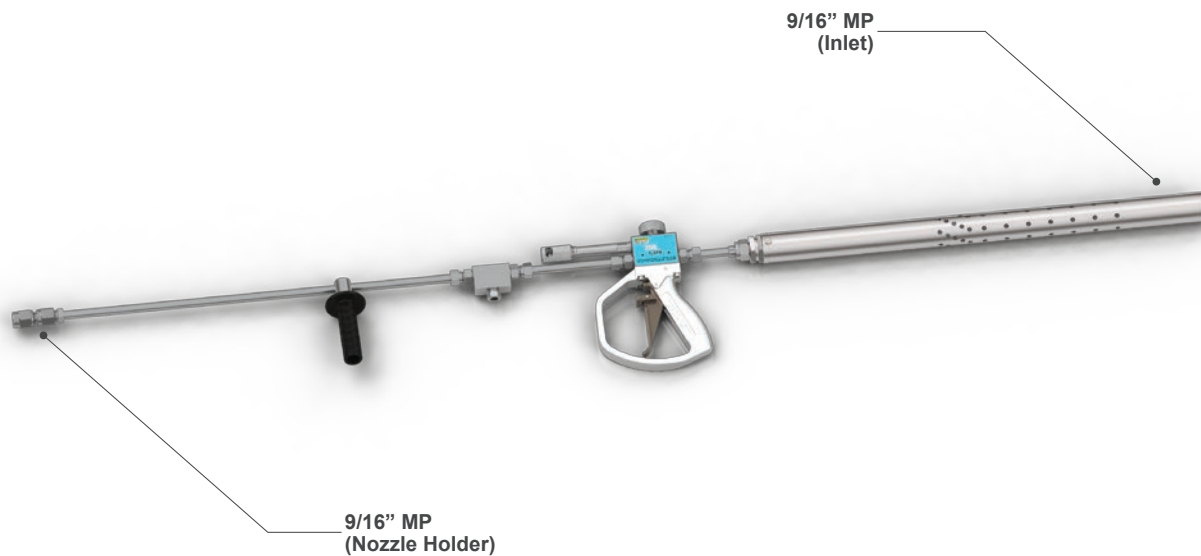

9/16" MP
(Nozzle Holder)

Paired for 20K psi Hand-Held Zero Thrust Gun...



21-007-004

9/16" MPM X 8MM (3/4"-16) TYPE M MALE 20K STAINLESS STEEL ADAPTER (AF 061-MP9) (GDWJ TYPE: 77211023)

40-027-4141-050C

4008ST X 50' 21.750K 8MM TYPE M STAINLESS STEEL FLEX LANCE B/E W/ COVER



60-020-010

20K HAND/FOOT GUN CARTRIDGE ASSEMBLY (J/S TYPE: 51869)

XX-XXX-XXX

INSERT DESCRIPTION HERE
...

40K psi HAND-HELD ZERO THRUST GUN

Assembly No. 60-040-012

Zero Thrust Guns are designed primarily for underwater use, where the self-canceling forwards and backwards thrusts allow the operator to carry out blasting operations without being propelled away from the intended work area. They also have application on dry land, where a balanced tool is needed, such as in a suspended gondola on the side of a building.

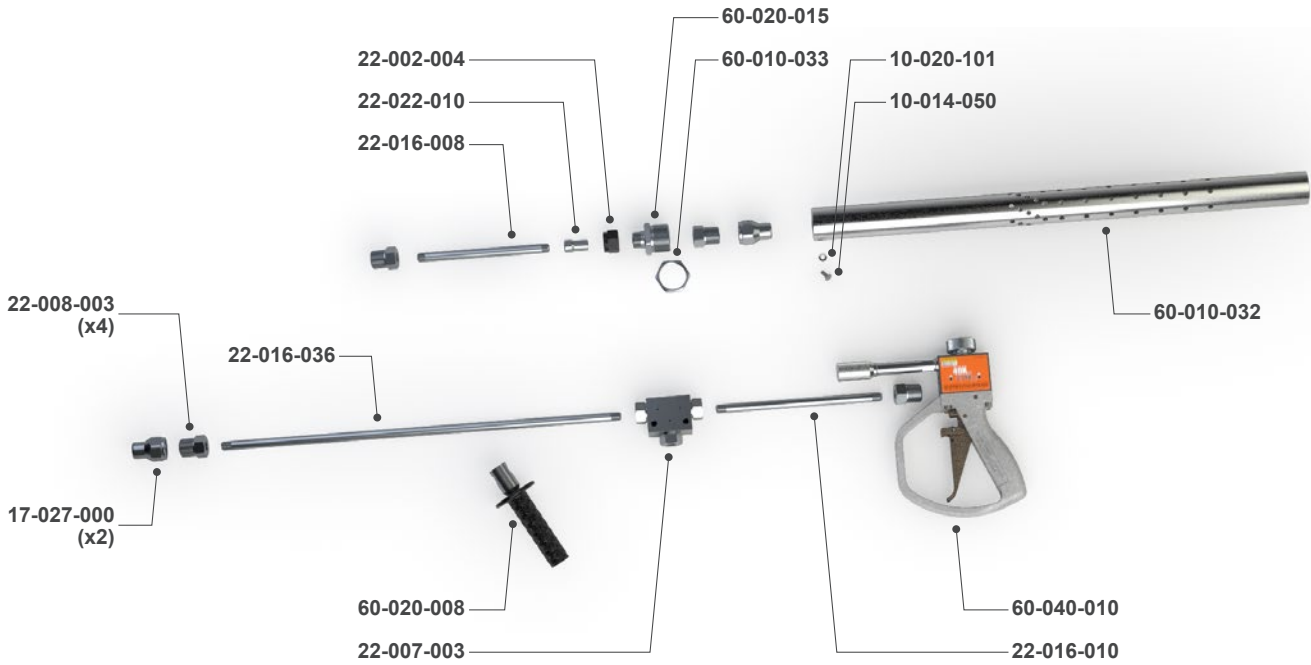

PART NO.	BILL OF MATERIALS (Assembly No. 60-040-012)	QUANTITY
10-014-050	1/4"-20 X 1/2" STAINLESS STEEL HEX HEAD BOLT	1
10-020-101	1/4" STAINLESS STEEL EXTERNAL TOOTH LOCK WASHER	1
17-027-000	9/16" HPF (1-1/8"-12) X 3/8"-24 UNF 40K NOZZLE HOLDER (F/ 40K DUMP GUN)	2
20-002-004	15/20K RIGID LANCE HOLDER COLLET NUT (DA) (GP 076)	1
20-022-010	0.562" I.D. F/ 9/16" MP RIGID LANCE HOLDER COLLET (100DA) (GP 075-562)	1
22-007-003	9/16" HP 60K TEE W/ GLAND & COLLAR	1
22-008-003	9/16" HP ANTI-VIBE COLLET ASSEMBLY (GLAND NUT, SPLIT COLLET & COLLAR) (J/S TYPE: 28090)	4
22-016-008	9/16" HP/LH X 8" 60K MAWP NIPPLE	1
22-016-010	9/16" HP/LH X 10" 60K MAWP NIPPLE	1
22-016-036	9/16" HP/LH X 36" 60K MAWP NIPPLE	1
60-010-032	ZERO THRUST GUN DIFFUSER (GDWJ TYPE: 77700058)	1
60-010-033	1-3/4"-12 ZERO THRUST GUN JAM NUT (GDWJ TYPE: 77700157)	1
60-020-008	9/16" 20/40K FRONT GUN HANDLE ASSEMBLY (ADJUSTABLE BARREL)	1
60-020-015	20/40K STAINLESS STEEL ZERO THRUST ADAPTER (GDWJ TYPE: 77700158)	1
60-040-010	9/16" HP 40K HAND GUN HANDLE ASSEMBLY	1

40K psi HAND-HELD ZERO THRUST GUN

Assembly No. 60-040-012



Paired for 40K psi Hand-Held Zero Thrust Gun...

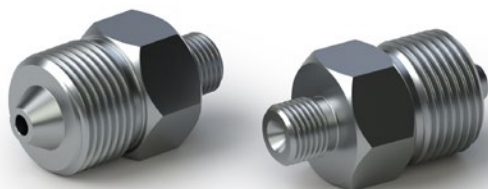

22-012-004

9/16" HPM X 5MM (9/16"-18) TYPE M 40K STAINLESS STEEL ADAPTER (GDWJ TYPE: 77211048)

44-021-031

40K X 6' SAFETY SHROUD, ADAPTER & WHIP HOSE ASSEMBLY (6105ST X 5MM TYPE M X 6')

15K psi HAND-HELD DRY SHUT-OFF GUN

Assembly No. 60-010-305

Enjoy the same benefits of our renowned Dump Style Control Guns with the added advantage of reduced water consumption, thus limiting the amount of waste to be removed from the work site.

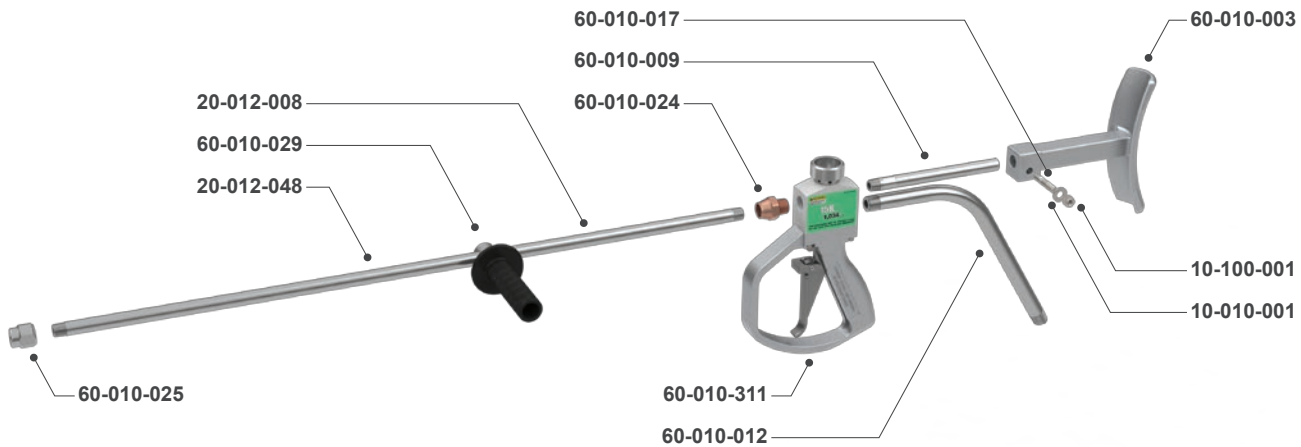

PART NO.	BILL OF MATERIALS (Assembly No. 60-010-305)	QUANTITY
10-010-001	3/8" FLAT STAINLESS STEEL WASHER	1
10-100-001	1/4"-20 STAINLESS STEEL NYLON LOCK NUT	1
20-012-048	3/8" NPT X 48" 15K STAINLESS STEEL NIPPLE (GDWJ TYPE: 77700106)	1
60-010-003	3/8" CONTROL GUN SHOULDER STOCK	1
60-010-009	SHOULDER STOCK REAR TUBE	1
60-010-012	1/2" NPT (BENT) 15K HANDGUN INLET TUBE	1
60-010-017	GUN SHOULDER STOCK CAM STUD ASSEMBLY (3/8" NPT BARREL)	1
60-010-024	1/2" NPTM X 3/8" NPTF GUN BARREL BUSHING W/ NIPPLE SUPPORT RELIEF (GDWJ TYPE: 77700636 OR 31045636)	1
60-010-025	3/8" NPT X 1/4" NPT 15K STAINLESS STEEL NOZZLE HOLDER (GDWJ TYPE: 7770087)	1
60-010-029	GUN FRONT HANDLE ASSEMBLY (3/8" NPT ADJUSTABLE BARREL)	1
60-010-311	15K DRY SHUT-OFF GUN HANDLE ASSEMBLY	1

15K psi HAND-HELD DRY SHUT-OFF GUN

Assembly No. 60-010-305

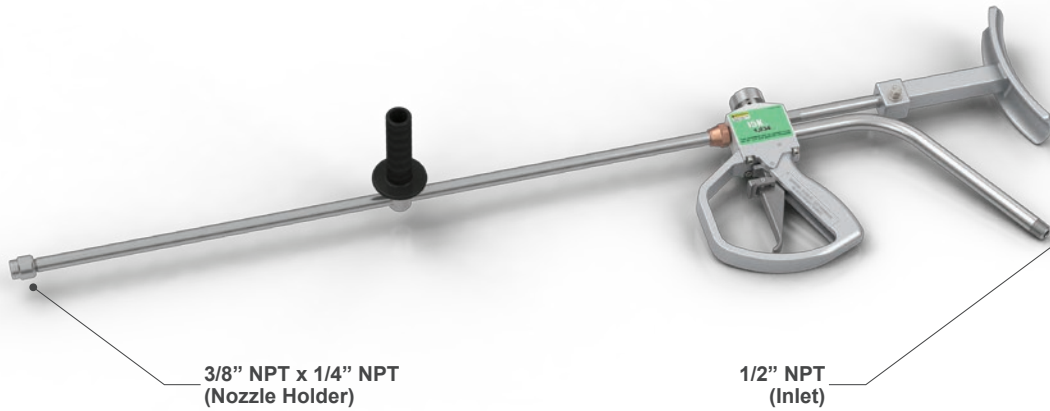

3/8" NPT x 1/4" NPT
(Nozzle Holder)

1/2" NPT
(Inlet)

Paired for 15K psi Hand-Held Dry Shut-Off Gun...



15-021-XXX

1/4" NPT 0.XXX" DIAMETER TUNGSTEN CARBIDE HARD HITTER NOZZLE (#XX)



20-003-008

1/2" NPT (15K MAWP) SCREW TYPE COUPLING ASSEMBLY (J/S TYPE: 50989)



44-020-003

1/2" NPT 15K WHIP HOSE X 6' ASSEMBLY, SAFETY SHROUD & ADAPTER (GDWJ TYPE: 77516032)



60-010-020

15K HAND/FOOT GUN CARTRIDGE ASSEMBLY (J/S TYPE: 50902)

15K psi HAND-HELD LEVER GUN

Assembly No. 60-030-004

The Lever Style Control Gun provides the same serviceability and safety features as the standard hand gun but in a style that is better suited to certain special applications, including hydro-excavation.

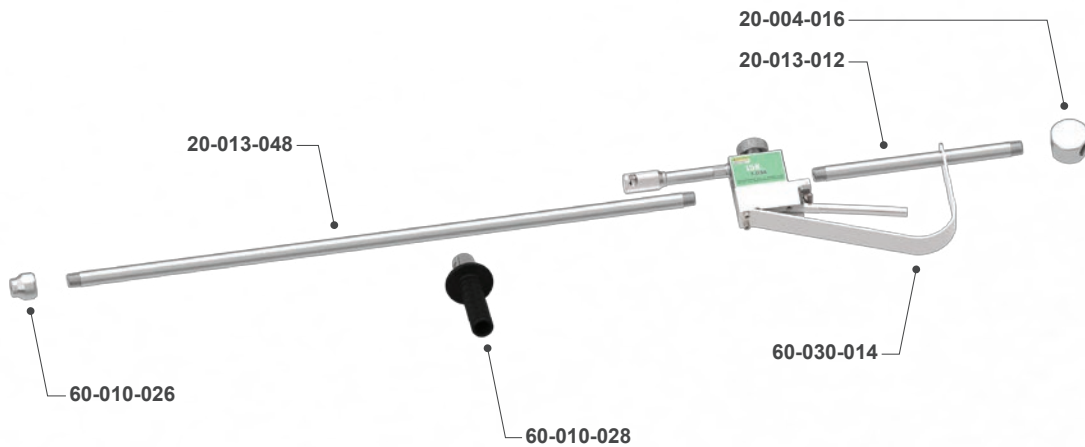

PART NO.	BILL OF MATERIALS (Assembly No. 60-030-004)	QUANTITY
20-004-016	1/2" NPT (15K MAWP) 45° WAFER ELBOW	1
20-013-012	1/2" NPT X 12" 15K STAINLESS STEEL NIPPLE	1
20-013-048	1/2" NPT X 48" 15K STAINLESS STEEL NIPPLE	1
60-010-026	1/2" NPT X 1/4" NPT NOZZLE HOLDER	1
60-010-028	GUN FRONT HANDLE ASSEMBLY (1/2" NPT ADJUSTABLE BARREL)	1
60-030-014	1/2" NPT 15K LEVER STYLE GUN HANDLE ASSEMBLY	1

15K psi HAND-HELD LEVER GUN

Assembly No. 60-030-004

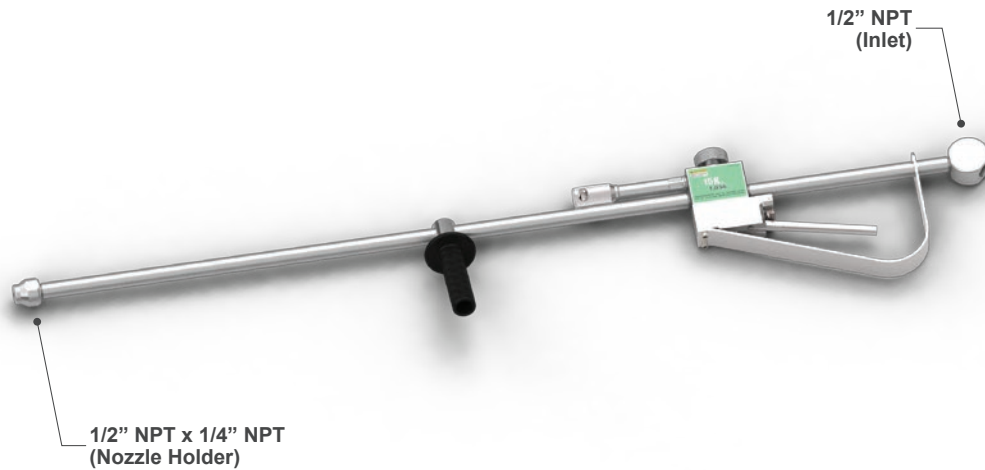

Paired for 15K psi Hand-Held Lever Gun...



15-021-XXX

1/4" NPT 0.XXX" DIAMETER TUNGSTEN CARBIDE HARD HITTER NOZZLE (#XX)



20-003-008

1/2" NPT (15K MAWP) SCREW TYPE COUPLING ASSEMBLY (J/S TYPE: 50989)



44-020-003

1/2" NPT 15K WHIP HOSE X 6' ASSEMBLY, SAFETY SHROUD & ADAPTER (GDWJ TYPE: 77516032)



60-010-020

15K HAND/FOOT GUN CARTRIDGE ASSEMBLY (J/S TYPE: 50902)

15K psi DUMP GUN HANDLE

Assembly No. 60-010-050

Complete Dump Gun Handle Assemblies are available, as well as the individual components.

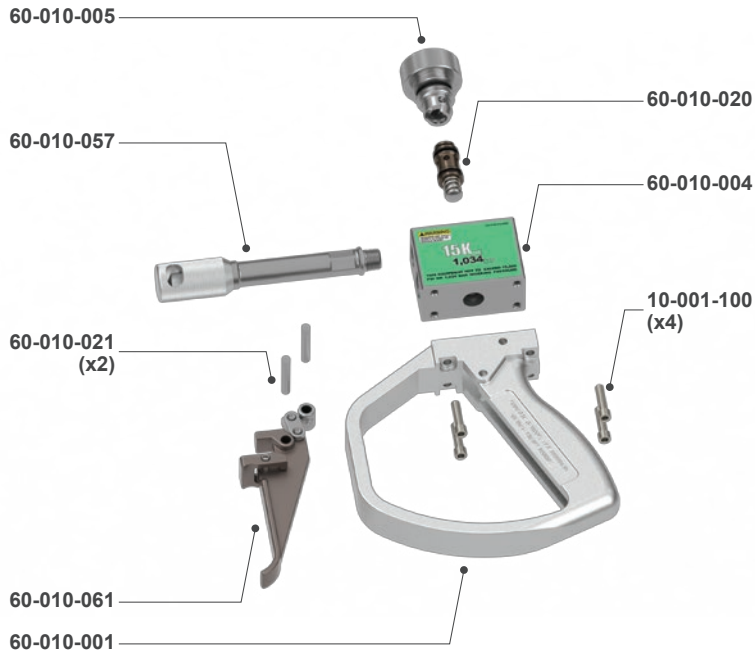

PART NO.	BILL OF MATERIALS (Assembly No. 60-010-050)	QUANTITY
10-001-100	1/4"-20 X 1" LONG STAINLESS STEEL SHCS SCREW (MIN YIELD 70K)	4
60-010-001	CONTROL GUN HANDLE	1
60-010-004	15K CONTROL GUN BLOCK	1
60-010-005	15K GUN CARTRIDGE NUT	1
60-010-020	15K HAND/FOOT GUN CARTRIDGE ASSEMBLY (J/S TYPE: 50902)	1
60-010-021	GUN TRIGGER PIVOT PIN	2
60-010-057	DUMP GUN TUBE ASSEMBLY (REVISED NEW STYLE)	1
60-010-061	SAFETY LATCH TRIGGER ASSEMBLY W/ LINKAGE (ALL HAND GUNS)	1

20K psi DUMP GUN HANDLE*Assembly No. 60-020-011*

This gun handle assembly is used in our 20K Hand-Held Dump Gun, Double Dump Gun and Zero Thrust Gun. All components listed below are included.

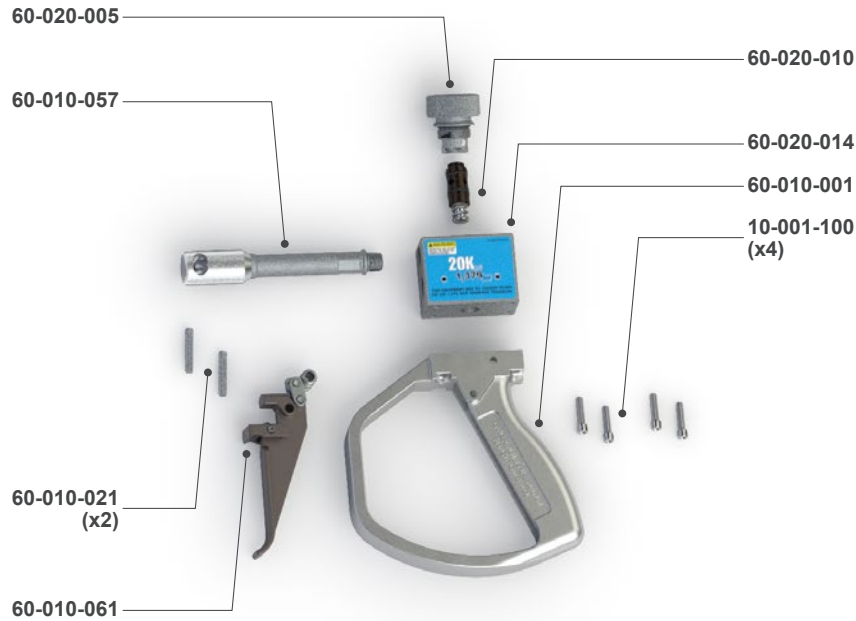

PART NO.	BILL OF MATERIALS (<i>Assembly No. 60-020-011</i>)	QUANTITY
10-001-100	1/4"-20 X 1" LONG STAINLESS STEEL SHCS SCREW (MIN YIELD 70K)	4
60-010-001	CONTROL GUN HANDLE	1
60-010-021	GUN TRIGGER PIVOT PIN	2
60-010-057	DUMP GUN TUBE ASSEMBLY (REVISED NEW STYLE)	1
60-010-061	SAFETY LATCH TRIGGER ASSEMBLY W/ LINKAGE (ALL HAND GUNS)	1
60-020-005	20K HAND GUN CARTRIDGE NUT	1
60-020-010	20K HAND/FOOT GUN CARTRIDGE ASSEMBLY (J/S TYPE: 51869)	1
60-020-014	20K CONTROL GUN BLOCK (NEW)	1

40K psi DUMP GUN HANDLE

Assembly No. 60-040-010

Complete Dump Gun Handle Assemblies are available, as well as the individual components. Contact our Customer Service for knowledgeable assistance.



PART NO.	BILL OF MATERIALS (Assembly No. 60-040-010)	QUANTITY
10-001-100	1/4"-20 X 1" LONG STAINLESS STEEL SHCS SCREW (MIN YIELD 70K)	4
60-010-001	CONTROL GUN HANDLE	1
60-010-021	GUN TRIGGER PIVOT PIN	2
60-010-057	DUMP GUN TUBE ASSEMBLY (REVISED NEW STYLE)	1
60-010-061	SAFETY LATCH TRIGGER ASSEMBLY W/ LINKAGE (ALL HAND GUNS)	1
60-040-001	COMPLETE 40K HAND GUN BLOCK	1
60-040-005	40K HAND/FOOT GUN CARTRIDGE ASSEMBLY (J/S TYPE: 53475)	1
60-040-006	40K CONTROL GUN CARTRIDGE NUT	1

15K psi DOUBLE DUMP GUN HANDLE

Assembly No. 60-050-007

Complete Dump Gun Handle Assemblies are available, as well as the individual components.

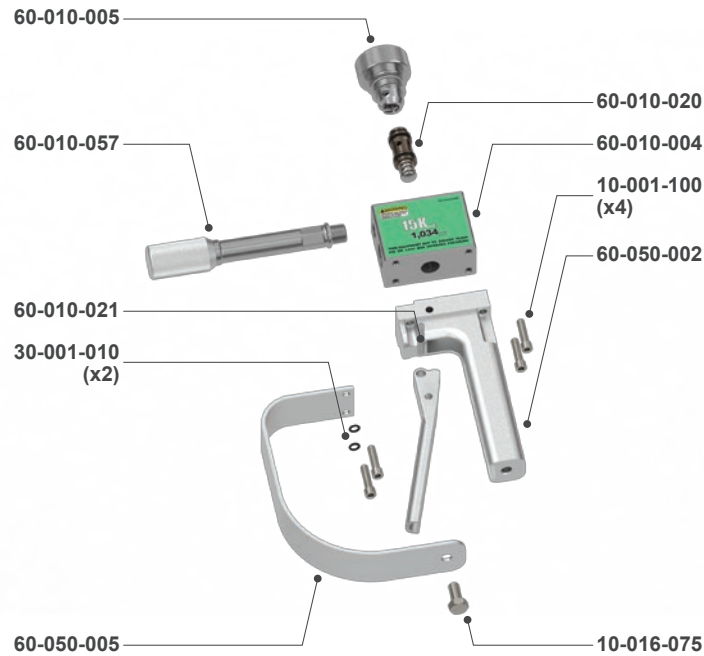

PART NO.	BILL OF MATERIALS (Assembly No. 60-050-007)	QUANTITY
10-001-100	1/4"-20 X 1" LONG STAINLESS STEEL SHCS SCREW (MIN YIELD 70K)	4
10-016-075	3/8"-16 X 3/4" STAINLESS STEEL HEX HEAD BOLT	1
30-001-010	2-010 BUNA-N 90 DURO O-RING (GDWJ TYPE: 22-09212)	2
60-010-004	15K CONTROL GUN BLOCK	1
60-010-005	15K GUN CARTRIDGE NUT	1
60-010-020	15K HAND/FOOT GUN CARTRIDGE ASSEMBLY (J/S TYPE: 50902)	1
60-010-021	GUN TRIGGER PIVOT PIN	1
60-010-022	NYLATRON BUSHING TRIGGER PIVOT PIN	1
60-010-057	DUMP GUN TUBE ASSEMBLY (REVISED NEW STYLE)	1
60-050-002	DOUBLE DUMP GUN HANDLE	1
60-050-003	DOUBLE DUMP GUN TRIGGER	1
60-050-005	DOUBLE DUMP GUN TRIGGER GUARD	1

20K psi DOUBLE DUMP GUN HANDLE

Assembly No. 60-055-002

This gun handle assembly is used as the front handle of our 20K Hand-Held Double Dump Gun. All components listed below are included.

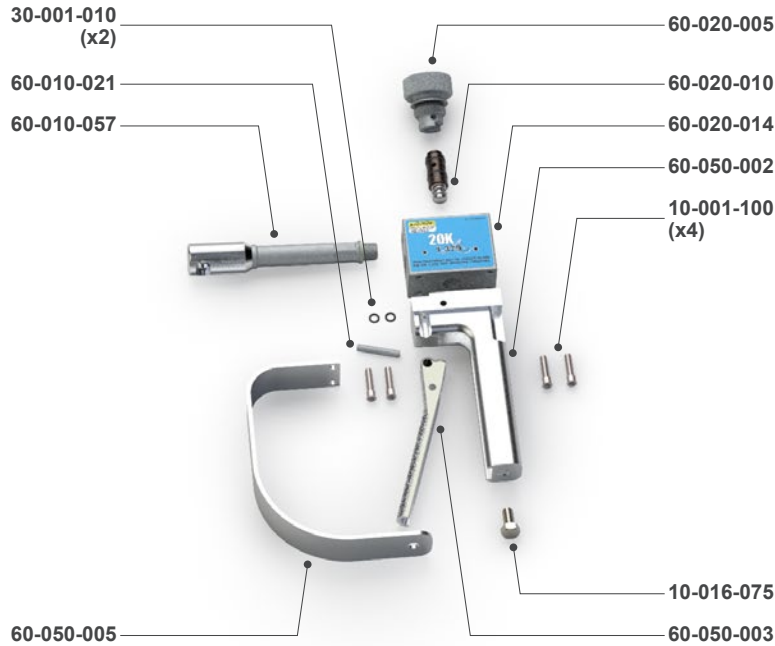

PART NO.	BILL OF MATERIALS (Assembly No. 60-055-002)	QUANTITY
10-001-100	1/4"-20 X 1" LONG STAINLESS STEEL SHCS SCREW (MIN YIELD 70K)	4
10-016-075	3/8"-16 X 3/4" STAINLESS STEEL HEX HEAD BOLT	1
30-001-010	2-010 BUNA-N 90 DURO O-RING (GDWJ TYPE: 22-09212)	2
60-010-021	GUN TRIGGER PIVOT PIN	1
60-010-022	NYLATRON TRIGGER PIVOT PIN BUSHING	1
60-010-057	DUMP GUN TUBE ASSEMBLY (REVISED NEW STYLE)	1
60-020-005	20K HAND GUN CARTRIDGE NUT ASSEMBLY	1
60-020-010	20K HAND/FOOT GUN CARTRIDGE ASSEMBLY (J/S TYPE: 51869)	1
60-020-014	20K CONTROL GUN BLOCK ASSEMBLY	1
60-050-002	DOUBLE DUMP GUN HANDLE	1
60-050-003	DOUBLE DUMP GUN TRIGGER	1
60-050-005	DOUBLE DUMP GUN TRIGGER GUARD	1

40K psi DOUBLE DUMP GUN HANDLE

Assembly No. 60-040-014

Complete Double Dump Gun Handle Assemblies are available, as well as the individual components.
Contact our Customer Service for knowledgeable assistance.

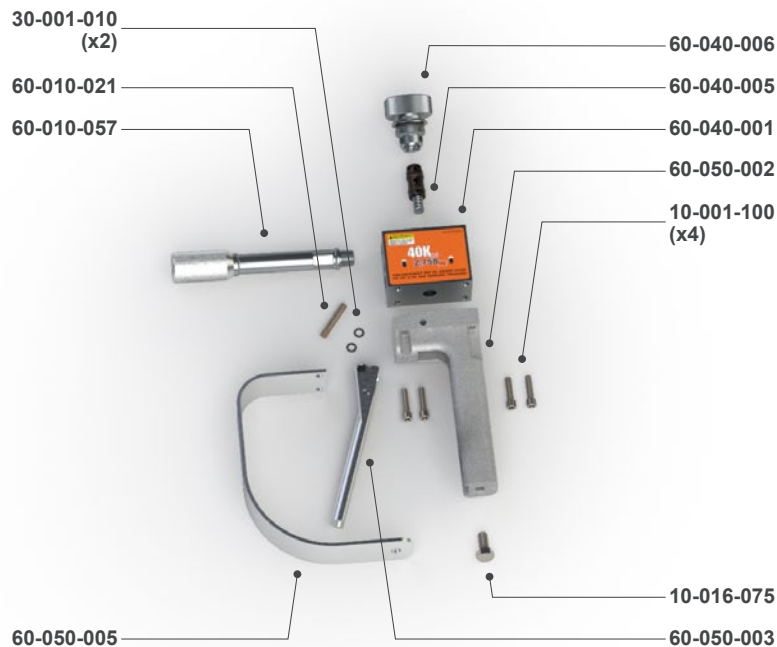

PART NO.	BILL OF MATERIALS (Assembly No. 60-040-014)	QUANTITY
10-001-100	1/4"-20 X 1" LONG STAINLESS STEEL SHCS SCREW (MIN YIELD 70K)	4
10-016-075	3/8"-16 X 3/4" STAINLESS STEEL HEX HEAD BOLT	1
30-001-010	2-010 BUNA-N 90 DURO O-RING (GDWJ TYPE: 22-09212)	2
60-010-021	GUN TRIGGER PIVOT PIN	1
60-010-022	NYLATRON TRIGGER PIVOT PIN BUSHING	1
60-010-057	DUMP GUN TUBE ASSEMBLY (REVISED NEW STYLE)	1
60-040-001	40K HAND GUN BLOCK ASSEMBLY	1
60-040-005	40K HAND/FOOT GUN CARTRIDGE ASSEMBLY (J/S TYPE: 53475)	1
60-040-006	40K CONTROL GUN CARTRIDGE NUT ASSEMBLY	1
60-050-002	DOUBLE DUMP GUN HANDLE	1
60-050-003	DOUBLE DUMP GUN TRIGGER	1
60-050-005	DOUBLE DUMP GUN TRIGGER GUARD	1

15K psi DRY SHUT-OFF GUN HANDLE

Assembly No. 60-010-311

Complete Dump Gun Handle Assemblies are available, as well as the individual components.

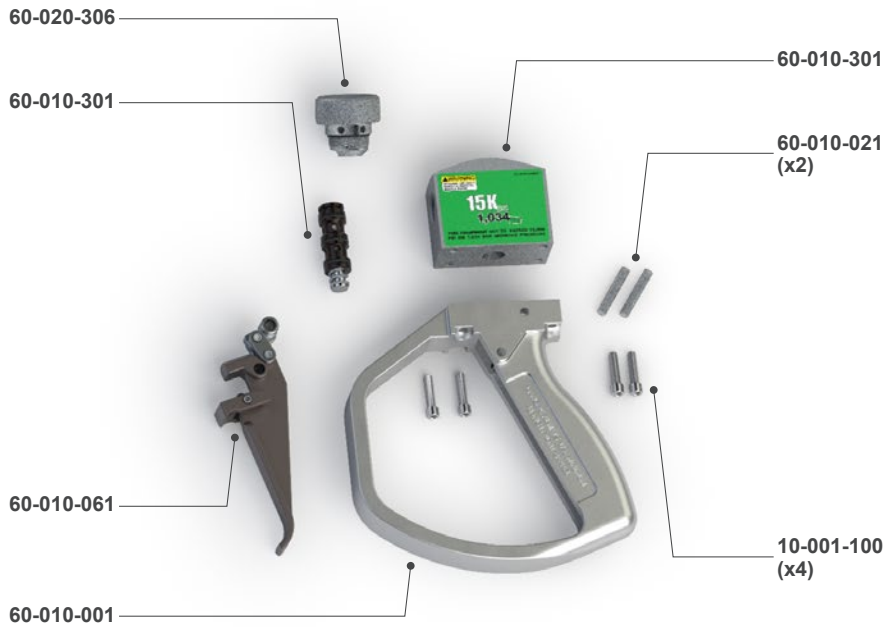

PART NO.	BILL OF MATERIALS (Assembly No. 60-010-311)	QUANTITY
10-001-100	1/4"-20 X 1" LONG STAINLESS STEEL SHCS SCREW (MIN YIELD 70K)	4
60-010-001	CONTROL GUN HANDLE	1
60-010-021	GUN TRIGGER PIVOT PIN	2
60-010-061	SAFETY LATCH TRIGGER ASSEMBLY W/ LINKAGE (ALL HAND GUNS)	1
60-010-301	15K DRY SHUT-OFF GUN BLOCK ASSEMBLY	1
60-010-304	15K DRY SHUT-OFF GUN CARTRIDGE ASSEMBLY (J/S TYPE: 52635 OR 60419)	1
60-020-306	20K DRY SHUT-OFF GUN CARTRIDGE NUT	1

15K psi LEVER GUN HANDLE

Assembly No. 60-030-014

Complete Dump Gun Handle Assemblies are available, as well as the individual components.

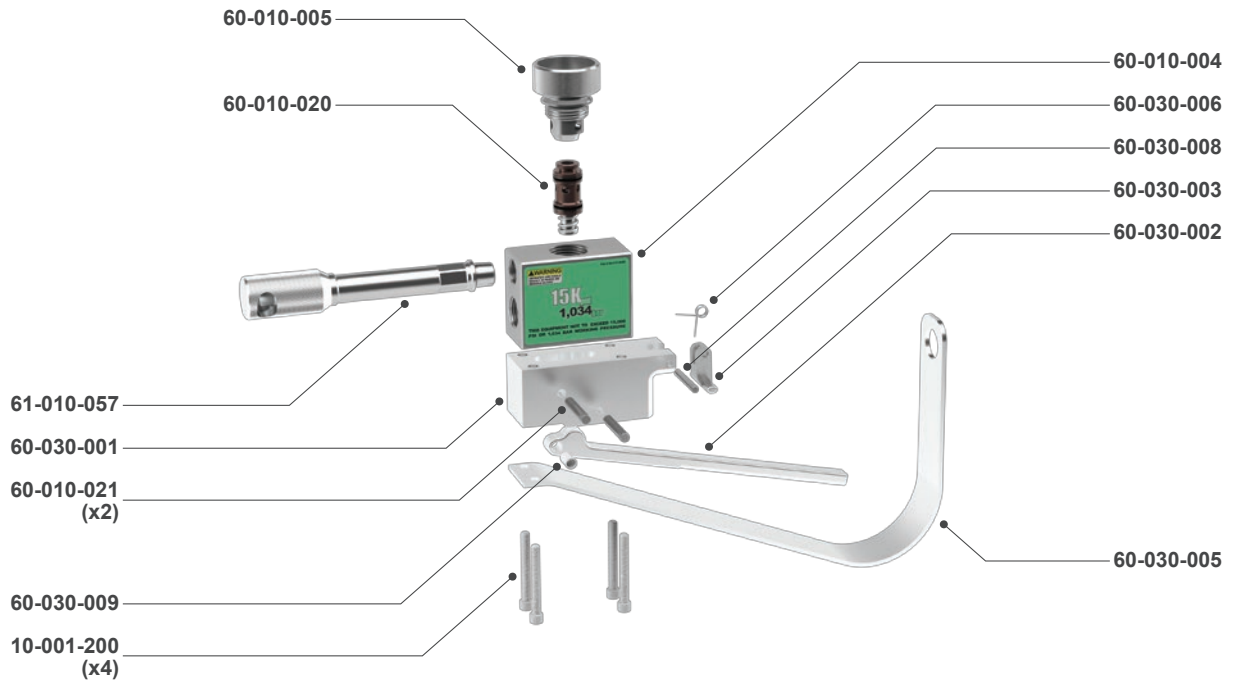

PART NO.	BILL OF MATERIALS (Assembly No. 60-030-014)	QUANTITY
10-001-200	1/4"-20 X 2" LONG STAINLESS STEEL SHCS SCREW (MIN YIELD 70K)	4
60-010-004	15K CONTROL GUN BLOCK ASSEMBLY	1
60-010-005	15K GUN CARTRIDGE NUT ASSEMBLY	1
60-010-020	15K HAND/FOOT GUN CARTRIDGE ASSEMBLY (J/S TYPE: 50902)	1
60-010-021	GUN TRIGGER PIVOT PIN	2
60-010-057	DUMP GUN TUBE ASSEMBLY (REVISED NEW STYLE)	1
60-030-001	LEVER STYLE GUN MOUNTING BLOCK	1
60-030-002	LEVER STYLE GUN TRIGGER PIVOT PIN BUSHING	1
60-030-003	GUN SAFETY LATCH	1
60-030-005	LEVER STYLE GUN TRIGGER GUARD	1
60-030-006	LEVER STYLE GUN SAFETY LATCH SPRING	1
60-030-008	LEVER STYLE GUN SAFETY LATCH PIVOT PIN	1
60-030-009	LEVER STYLE GUN TRIGGER PIVOT PIN BUSHING	1

DUMP CARTRIDGES

Dump and Dry Shut-Off Style Cartridges enable hand lances, foot valves and air diverter valves to be quickly and easily rebuilt in the field. Similarly, cartridges for the Flow Divider Valves and Pressure Regulating Valves also enable rapid field replacement and servicing.



60-010-020

15K HAND/FOOT GUN CARTRIDGE ASSEMBLY
(J/S TYPE: 50902)



60-100-004

15K GDWJ STYLE HAND/FOOT GUN CARTRIDGE ASSEMBLY (GDWJ TYPE: 3102111)



61-050-012

15K HIGH VOLUME FOOT GUN CARTRIDGE ASSEMBLY



60-020-010

20K HAND/FOOT GUN CARTRIDGE ASSEMBLY (J/S TYPE: 51869)



60-200-003

20K GDWJ STYLE GUN CARTRIDGE ASSEMBLY (GDWJ TYPE: 3102121)

DUMP CARTRIDGES

(Continued)



61-020-030

CF H/F MAG CARTRIDGE ASSEMBLY (USED IN 15K & 22K)
(J/S TYPE: 52750)



99-107-000

WEATHERFORD F-20/M-20 VALVE & SEAL KIT
(GDWJ TYPE: 432021001)



60-040-005

40K HAND/FOOT GUN CARTRIDGE ASSEMBLY
(J/S TYPE: 53475)



60-300-001

40K GDWJ STYLE HAND/FOOT GUN CARTRIDGE
ASSEMBLY (GDWJ TYPE: 77700315)

VALVE CARTRIDGES

Dump and Dry Shut-Off Style Cartridges enable hand lances, foot valves and air diverter valves to be quickly and easily rebuilt in the field. Similarly, cartridges for the Flow Divider Valves and Pressure Regulating Valves also enable rapid field replacement and servicing.



60-010-355

15K UNLOADER VALVE CARTRIDGE ASSEMBLY
(SEAT & VALVE) (J/S TYPE: 55530)



60-100-006

15K DRY SHUT-OFF GUN CARTRIDGE
VALVE ASSEMBLY (GDWJ TYPE: 77700500)



61-050-026

C-15 1" CARTRIDGE ASSEMBLY (1" VALVES)
(J/S TYPE: 53915)



65-030-009

HIGH VOLUME PRESSURE REGULATING VALVE
CARTRIDGE ASSEMBLY (12K WP)



70-010-004

15K FLOW DIVIDER VALVE / PRESSURE REGULATING
VALVE CARTRIDGE ASSEMBLY (J/S TYPE: 50234)

VALVE CARTRIDGES

(Continued)



70-020-011

20K FLOW DIVIDER VALVE / PRESSURE REGULATING
VALVE CARTRIDGE ASSEMBLY (J/S TYPE: 52255)



60-070-111

40K TRI-MODE TUMBLE BOX CARTRIDGE ASSEMBLY
(NEW STYLE: X15TN)



60-500-006

TRI-MODE TUMBLE BOX CARTRIDGE ASSEMBLY
(J/S TYPE: 54014)



65-040-001

40K PRESSURE REGULATING VALVE
CARTRIDGE ASSEMBLY (J/S TYPE: 53725)



99-003-019

MULTI-MODE REPAIR CARTRIDGE
(GDWJ TYPE: 77408803 ASSEMBLY)

DRY SHUT-OFF CARTRIDGES

Dump and Dry Shut-Off Style Cartridges enable hand lances, foot valves and air diverter valves to be quickly and easily rebuilt in the field. Similarly, cartridges for the Flow Divider Valves and Pressure Regulating Valves also enable rapid field replacement and servicing.



60-010-304

15K SHUT-OFF GUN CARTRIDGE ASSEMBLY
(J/S TYPE: 52635)



60-020-302

20K DRY SHUT-OFF CARTRIDGE ASSEMBLY
(J/S TYPE: 52640)

TYPES 3615HF & 4215HF FLUID ENDS SPECS

APS Fluid Ends are the latest in our comprehensive line of water blasting equipment solutions and is the new gold standard in precision machined pump parts. Superior quality, combined with the experience and know-how at APS, enables us to provide cost-effective products that outperform other industry manufacturers. Models available up to 20K psi (1379 bar). The APS Fluid Ends are available as replacements for outdated models or as an upgrade to lower pressure rated systems.

Features:

- Quick change valve assemblies make field replacement simple
 - Valves and plungers are cartridge format for easy servicing
 - Special tools and equipment are not required
 - High volumetric efficiency
 - Simple design requires fewer spare parts
- APS manufacturing assures superior quality

Fluid End Part No.	Fluid End Model	Plunger Size	Plunger Diameter in. / (mm)	Plunger Stroke in. / (mm)	RPM Range	Power HP / (kW)	Pressure psi / (bar)	Flow gpm / (lpm)
25-004-648	Type-4215HF	10	0.980 / (24.89)	4.25 / (108)	150-520	210 / (157)	15K / (1034)	21.7 / (82)
25-004-649	Type-4215HF	11	1.100 / (27.94)	4.25 / (108)	150-520	260 / (194)	15K / (1034)	26.9 / (102)
25-004-649	Type-4215HF	11	1.100 / (27.94)	4.25 / (108)	150-520	210 / (157)	12K / (827)	27.1 / (103)
25-004-650	Type-4215HF	12	1.200 / (30.48)	4.25 / (108)	150-520	325 / (242)	15K / (1034)	32.5 / (123)
25-004-650	Type-4215HF	12	1.200 / (30.48)	4.25 / (108)	150-520	260 / (194)	12.5K / (862)	32.2 / (122)
25-004-650	Type-4215HF	12	1.200 / (30.48)	4.25 / (108)	150-520	210 / (157)	10K / (689)	32.5 / (123)
25-004-651	Type-4215HF	13	1.335 / (33.91)	4.25 / (108)	150-520	325 / (242)	12.5K / (862)	40.2 / (152)
25-004-651	Type-4215HF	13	1.335 / (33.91)	4.25 / (108)	150-520	260 / (194)	10K / (689)	40.2 / (152)
25-004-651	Type-4215HF	13	1.335 / (33.91)	4.25 / (108)	150-520	210 / (157)	8K / (552)	40.2 / (152)
25-004-652	Type-4215HF	15	1.500 / (38.10)	4.25 / (108)	150-520	325 / (242)	10K / (689)	50.4 / (191)
25-004-652	Type-4215HF	15	1.500 / (38.10)	4.25 / (108)	150-520	260 / (194)	8K / (552)	50.4 / (191)
25-004-652	Type-4215HF	15	1.500 / (38.10)	4.25 / (108)	150-520	210 / (157)	6.5K / (448)	50.1 / (190)
25-004-657	Type-4215HF	16	1.670 / (42.42)	4.25 / (108)	150-520	325 / (242)	8K / (552)	62.9 / (238)
25-004-657	Type-4215HF	16	1.670 / (42.42)	4.25 / (108)	150-520	260 / (194)	6.5K / (448)	62.0 / (235)
25-004-657	Type-4215HF	16	1.670 / (42.42)	4.25 / (108)	150-520	210 / (157)	5K / (345)	62.9 / (238)
25-004-647	Type-3615HF	9	0.900 / (22.86)	3.63 / (92)	150-550	150 / (112)	15K / (1034)	15.5 / (59)
25-004-648	Type-3615HF	10	0.980 / (24.89)	3.63 / (92)	150-550	175 / (130)	15K / (1034)	18.1 / (68)
25-004-648	Type-3615HF	10	0.980 / (24.89)	3.63 / (92)	150-550	150 / (112)	12K / (827)	19.4 / (73)
25-004-649	Type-3615HF	11	1.100 / (27.94)	3.63 / (92)	150-550	175 / (130)	12K / (827)	22.6 / (86)
25-004-649	Type-3615HF	11	1.100 / (27.94)	3.63 / (92)	150-550	150 / (112)	10K / (689)	23.3 / (88)
25-004-650	Type-3615HF	12	1.200 / (30.48)	3.63 / (92)	150-550	175 / (130)	10K / (689)	27.1 / (103)
25-004-650	Type-3615HF	12	1.200 / (30.48)	3.63 / (92)	150-550	150 / (112)	8K / (552)	29.1 / (110)
25-004-651	Type-3615HF	13	1.335 / (33.91)	3.63 / (92)	150-550	175 / (130)	8K / (552)	33.9 / (128)
25-004-651	Type-3615HF	13	1.335 / (33.91)	3.63 / (92)	150-550	150 / (112)	6.5K / (448)	35.8 / (136)
25-004-652	Type-3615HF	15	1.500 / (38.10)	3.63 / (92)	150-550	175 / (130)	6K / (414)	45.2 / (171)
25-004-652	Type-3615HF	15	1.500 / (38.10)	3.63 / (92)	150-550	150 / (112)	5K / (345)	45.5 / (172)

Special manifold with adapter plates available.

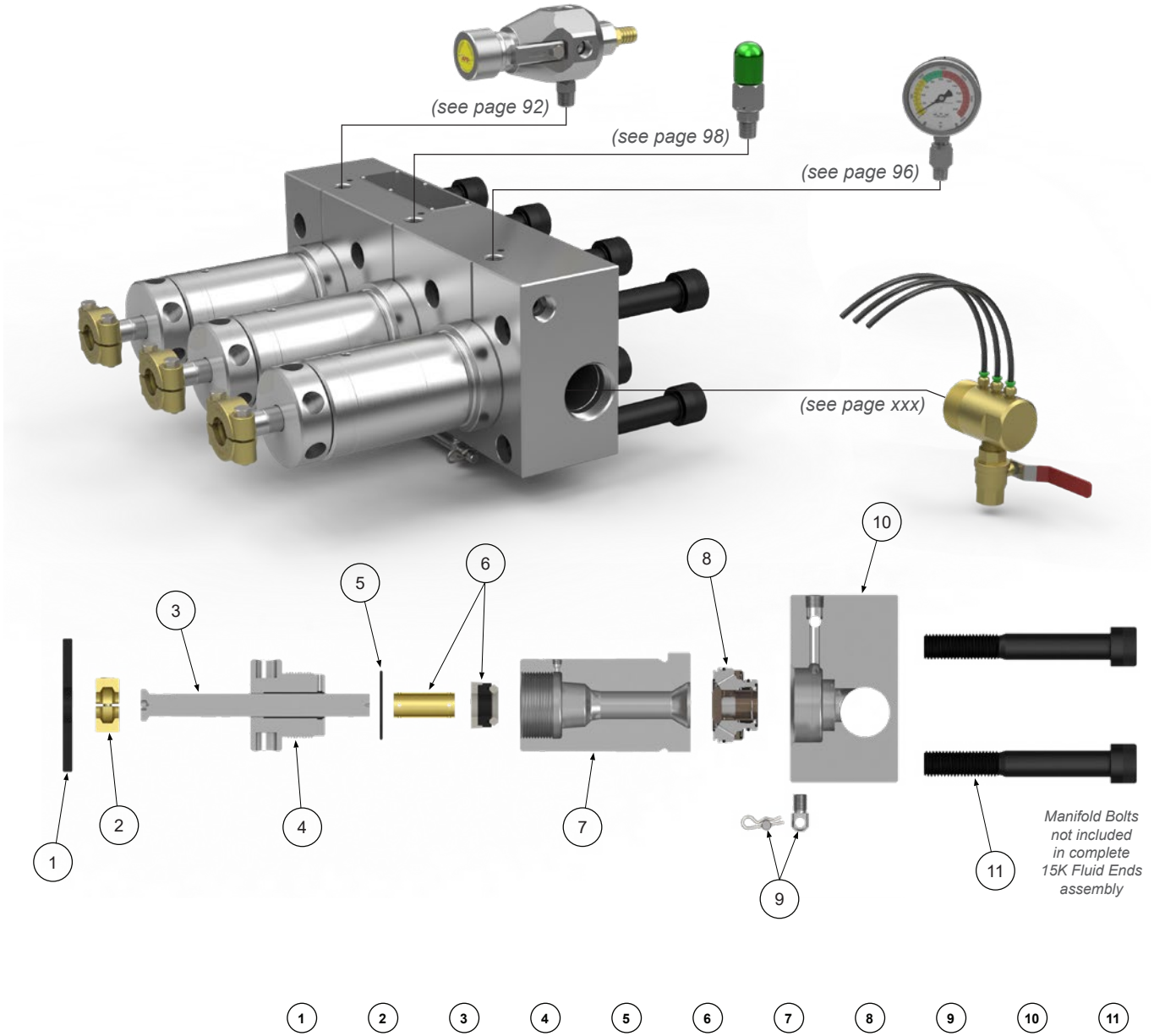

Manifold Bolts
not included
in complete
15K Fluid Ends
assembly

Part No. Complete Assembly	Fluid Ends Type	Plunger Size	Deflector	Plunger Coupling	Plunger	Gland Nut	Gland Nut O-Ring	Packing Set	Stuffing Box	Valve	Trunnion	Manifold	Manifold Bolts
25-004-648	4215HF	10	25-004-641	25-004-613	25-004-604	25-004-616	25-004-643	25-004-627	25-004-635	25-004-458	25-004-645	25-004-600	25-004-656
25-004-649	4215HF	11	25-004-641	25-004-613	25-004-605	25-004-617	25-004-643	25-004-628	25-004-635	25-004-458	25-004-645	25-004-600	25-004-656
25-004-650	4215HF	12	25-004-641	25-004-613	25-004-606	25-004-618	25-004-643	25-004-629	25-004-636	25-004-458	25-004-645	25-004-600	25-004-656
25-004-651	4215HF	13	25-004-641	25-004-613	25-004-607	25-004-619	25-004-643	25-004-630	25-004-636	25-004-458	25-004-645	25-004-600	25-004-656
25-004-652	4215HF	15	25-004-641	25-004-613	25-004-608	25-004-620	25-004-643	25-004-631	25-004-636	25-004-458	25-004-645	25-004-600	25-004-656
25-004-647	3615HF	9	25-004-641	25-004-613	25-004-603	25-004-615	25-004-643	25-004-626	25-004-635	25-004-458	25-004-645	25-004-600	25-004-656
25-004-648	3615HF	10	25-004-641	25-004-613	25-004-604	25-004-616	25-004-643	25-004-627	25-004-635	25-004-458	25-004-645	25-004-600	25-004-656
25-004-649	3615HF	11	25-004-641	25-004-613	25-004-605	25-004-617	25-004-643	25-004-628	25-004-635	25-004-458	25-004-645	25-004-600	25-004-656
25-004-650	3615HF	12	25-004-641	25-004-613	25-004-606	25-004-618	25-004-643	25-004-629	25-004-636	25-004-458	25-004-645	25-004-600	25-004-656
25-004-651	3615HF	13	25-004-641	25-004-613	25-004-607	25-004-619	25-004-643	25-004-630	25-004-636	25-004-458	25-004-645	25-004-600	25-004-656
25-004-652	3615HF	15	25-004-641	25-004-613	25-004-608	25-004-620	25-004-643	25-004-631	25-004-636	25-004-458	25-004-645	25-004-600	25-004-656

PART NUMBER CROSSOVER TABLE (APS to J/S)

Types 3615HF & 4215HF

Part No. Complete Assembly		Fluid Ends Type	Plunger Size	Plunger		Gland Nut		Packing Set		Stuffing Box		Uni-Valve		Manifold	
J/S	APS			J/S	APS	J/S	APS	J/S	APS	J/S	APS	J/S	APS	J/S	APS
53090	25-004-648	4215HF	10	51721	25-004-604	51647	25-004-616	50658	25-004-627	52872	25-004-635	52870	25-004-458	52864	25-004-600
53095	25-004-649	4215HF	11	51722	25-004-605	51651	25-004-617	50659	25-004-628	52872	25-004-635	52870	25-004-458	52864	25-004-600
53100	25-004-650	4215HF	12	51723	25-004-606	51707	25-004-618	50660	25-004-629	52873	25-004-636	52870	25-004-458	52864	25-004-600
53105	25-004-651	4215HF	13	51724	25-004-607	51744	25-004-619	50661	25-004-630	52873	25-004-636	52870	25-004-458	52864	25-004-600
53110	25-004-652	4215HF	15	51726	25-004-608	51746	25-004-620	50662	25-004-631	52873	25-004-636	52870	25-004-458	52864	25-004-600
53085	25-004-647	3615HF	9	51808	25-004-603	51809	25-004-615	51802	25-004-626	52872	25-004-635	52870	25-004-458	52864	25-004-600
53090	25-004-648	3615HF	10	51721	25-004-604	51647	25-004-616	50658	25-004-627	52872	25-004-635	52870	25-004-458	52864	25-004-600
53095	25-004-649	3615HF	11	51722	25-004-605	51651	25-004-617	50659	25-004-628	52872	25-004-635	52870	25-004-458	52864	25-004-600
53100	25-004-650	3615HF	12	51723	25-004-606	51707	25-004-618	50660	25-004-629	52873	25-004-636	52870	25-004-458	52864	25-004-600
53105	25-004-651	3615HF	13	51724	25-004-607	51744	25-004-619	50661	25-004-630	52873	25-004-636	52870	25-004-458	52864	25-004-600
53110	25-004-652	3615HF	15	51726	25-004-608	51746	25-004-620	50662	25-004-631	52873	25-004-636	52870	25-004-458	52864	25-004-600

These components are typical for all 15K & 20K psi Fluid Ends

Deflector		Plunger Coupling		Gland Nut O-Ring		Trunnion		Trunnion Rod		Manifold Bolt		Lube Harness	
J/S	APS	J/S	APS	J/S	APS	J/S	APS	J/S	APS	J/S	APS	J/S	APS
26487	25-004-641	51736	25-004-613	26387	25-004-643	51659	25-004-645	50295	25-004-646	26500	25-004-656	51975	25-004-646

TYPES 3620 & 4220 FLUID ENDS SPECS

APS Fluid Ends are the latest in our comprehensive line of water blasting equipment solutions and is the new gold standard in precision machined pump parts. Superior quality, combined with the experience and know-how at APS, enables us to provide cost-effective products that outperform other industry manufacturers. Models available up to 20K psi (1379 bar). The APS Fluid Ends are available as replacements for outdated models or as an upgrade to lower pressure rated systems.

Features:

- Quick change valve assemblies make field replacement simple
 - Valves and plungers are cartridge format for easy servicing
 - Special tools and equipment are not required
 - High volumetric efficiency
 - Simple design requires fewer spare parts
- APS manufacturing assures superior quality

Fluid End Part No.	Fluid End Model	Plunger Size	Plunger Diameter in. / (mm)	Plunger Stroke in. / (mm)	RPM Range	Power HP / (kW)	Pressure psi / (bar)	Flow gpm / (lpm)
25-004-653	Type-4220	8	0.800 / (20.32)	4.25 / (108)	520	186 / (139)	20K / (1379)	14.44 / (55)
25-004-654	Type-4220	9	0.900 / (22.86)	4.25 / (108)	520	235 / (175)	20K / (1379)	18.27 / (69)
25-004-655	Type-4220	10	0.980 / (20.32)	4.25 / (108)	520	280 / (209)	20K / (1379)	21.66 / (82)
25-004-658	Type-4220	11	1.100 / (27.94)	4.25 / (108)	520	325 / (242)	20K / (1379)	25.22 / (95)
25-004-653	Type-3620	8	0.800 / (20.32)	3.63 / (92)	550	168 / (125)	20K / (1379)	15.27 / (58)

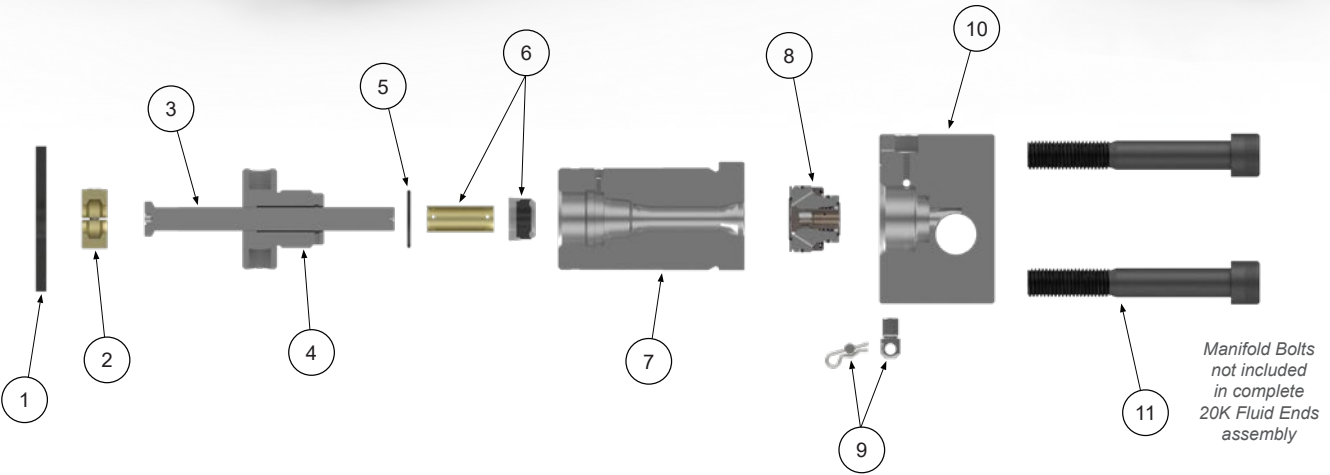
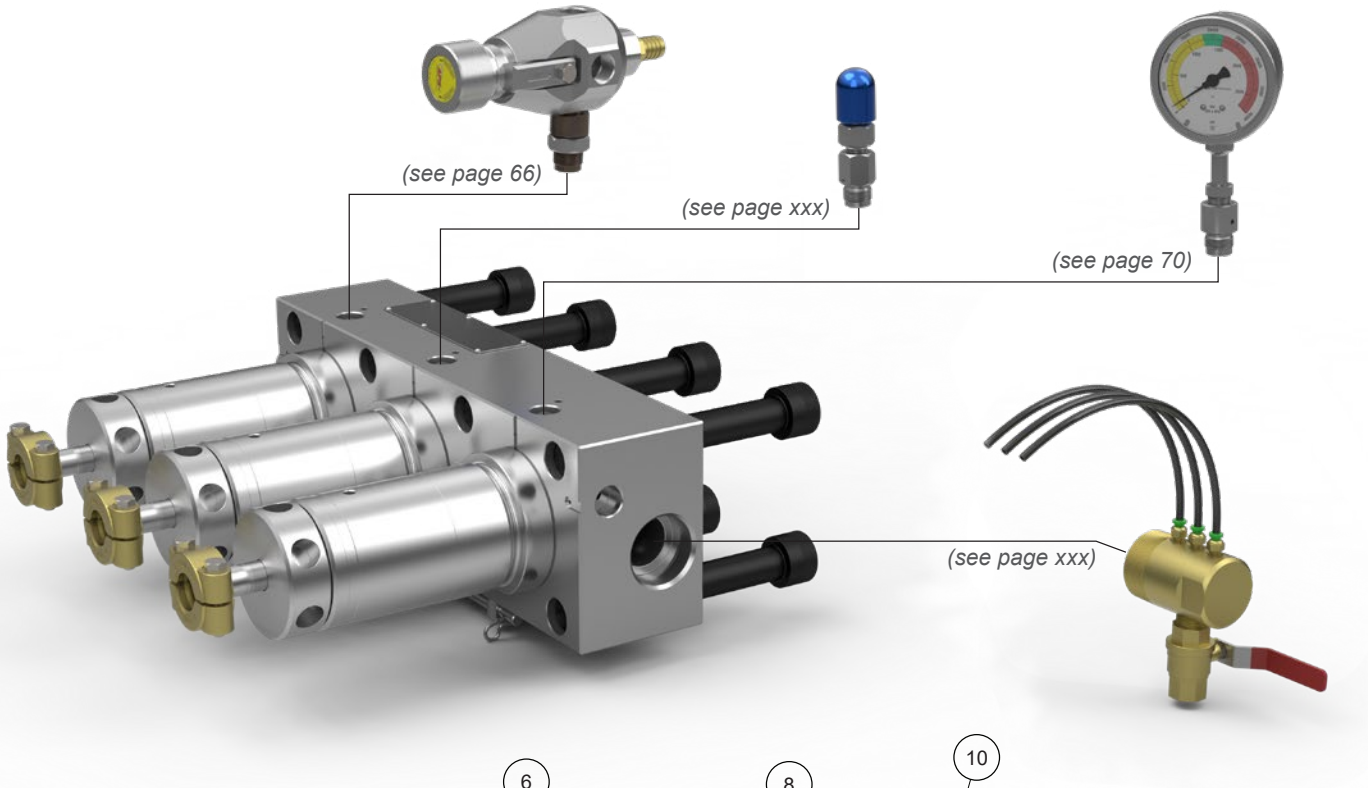

- 1
- 2
- 3
- 4
- 5
- 6
- 7
- 8
- 9
- 10
- 11

Part No. Complete Assembly	Fluid Ends Type	Plunger Size	Deflector	Plunger Coupling	Plunger	Gland Nut	Gland Nut O-Ring	Packing Set	Stuffing Box	Valve	Trunnion	Manifold	Manifold Bolts
25-004-653	4220	8	25-004-641	25-004-613	25-004-609	25-004-644	25-004-625	25-004-632	25-004-639	25-004-407	25-004-645	25-004-601	25-004-656
25-004-654	4220	9	25-004-641	25-004-613	25-004-610	25-004-622	25-004-625	25-004-633	25-004-639	25-004-407	25-004-645	25-004-601	25-004-656
25-004-655	4220	10	25-004-641	25-004-613	25-004-611	25-004-623	25-004-625	25-004-634	25-004-640	25-004-407	25-004-645	25-004-601	25-004-656
25-004-658	4220	11	25-004-641	25-004-613	25-004-612	25-004-624	25-004-625	25-004-614	25-004-640	25-004-407	25-004-645	25-004-601	25-004-656
25-004-653	3620	8	25-004-641	25-004-613	25-004-609	25-004-644	25-004-625	25-004-632	25-004-639	25-004-407	25-004-645	25-004-601	25-004-656

PART NUMBER CROSSOVER TABLE (APS to J/S)

Types 4220 & 3620

Part No. Complete Assembly		Fluid End Type	Plunger Size	Plunger		Gland Nut		Packing Set		Stuffing Box		Uni-Valve		Manifold	
J/S	APS			J/S	APS	J/S	APS	J/S	APS	J/S	APS	J/S	APS	J/S	APS
51995	25-004-653	4220	8	50301	25-004-609	51832	25-004-644	51857	25-004-632	50306	25-004-639	51790	25-004-407	51818	25-004-601
52000	25-004-654	4220	9	51828	25-004-610	51829	25-004-622	51826	25-004-633	50306	25-004-639	51790	25-004-407	51818	25-004-601
52506	25-004-655	4220	10	52504	25-004-611	52501	25-004-623	52509	25-004-634	52502	25-004-640	51790	25-004-407	51818	25-004-601
54965	25-004-658	4220	11	54966	25-004-612	54828	25-004-624	55877	25-004-614	52502	25-004-640	51790	25-004-407	51818	25-004-601
51995	25-004-653	3620	8	50301	25-004-609	51832	25-004-644	51857	25-004-632	50306	25-004-639	51790	25-004-407	51818	25-004-601

These components are typical for all 15K & 20K Fluid Ends

Deflector		Plunger Coupling		Gland Nut O-Ring		Trunnion		Trunnion Rod		Manifold Bolt		Lube Harness	
J/S	APS	J/S	APS	J/S	APS	J/S	APS	J/S	APS	J/S	APS	J/S	APS
26487	25-004-641	51736	25-004-613	26387	25-004-643	51659	25-004-645	50295	25-004-646	26500	25-004-656	51975	25-004-646

PRESSURE GAUGES

We offer a complete range of pressure gauges designed specifically for water blasting applications.



PART NO.	PRESSURE GAUGES	INLET	MAX PRESSURE
35-001-003	4" STAINLESS STEEL 0-20K RANGE GF BOTTOM MOUNT PRESSURE GAUGE (NUOVA FIMA) (GDWJ TYPE: 77512020) (J/S TYPE: 25771) (NLB TYPE: 2008)	1/2" NPTM	15K psi (1034 bar)
35-001-004	6" STAINLESS STEEL 0-20K RANGE GF BOTTOM MOUNT PRESSURE GAUGE (NUOVA FIMA)	1/2" NPTM	15K psi (1034 bar)
35-001-024	4" STAINLESS STEEL 0-20K RANGE BOTTOM MOUNT PRESSURE GAUGE	1/2" BSPPM	15K psi (1034 bar)
35-001-033	4" STAINLESS STEEL 0-30K RANGE GF BOTTOM MOUNT PRESSURE GAUGE (NUOVA FIMA)	1/2" NPTM	15K psi (1034 bar)
35-001-005	4" STAINLESS STEEL 0-40K RANGE GF BOTTOM MOUNT PRESSURE GAUGE (NUOVA FIMA)	1/4" HPF	20K psi (1379 bar)
35-001-025	4" STAINLESS STEEL 0-40K RANGE GF TUBE NIPPLE BOTTOM MOUNT PRESSURE GAUGE (NUOVA FIMA) (GDWJ TYPE: 77512019) (J/S TYPE: 52498)	9/16" HP	20K psi (1379 bar)
35-001-007	6" STAINLESS STEEL 0-60K RANGE GF BOTTOM MOUNT PRESSURE GAUGE (NUOVA FIMA)	1/4" HPF (9/16"-18 RHF)	40K psi (2758 bar)
35-001-012	4" STAINLESS STEEL 0-60K RANGE GF BOTTOM MOUNT PRESSURE GAUGE (NUOVA FIMA) (NLB TYPE: 5008)	1/4" HPF	40K psi (2758 bar)
35-001-027	4" STAINLESS STEEL 0-60K RANGE GF TUBE NIPPLE BOTTOM MOUNT PRESSURE GAUGE (NUOVA FIMA)	9/16" HPM	40K psi (2758 bar)
35-001-028	6" STAINLESS STEEL 0-60K RANGE GF TUBE NIPPLE BOTTOM MOUNT PRESSURE GAUGE (NUOVA FIMA)	9/16" HPM	40K psi (2758 bar)

SNUBBERS

Snubbers absorb the system pressure pulses that can cause gauge fluctuations. Our Ray Snubber enhances accuracy and extends the service life of the gauge.

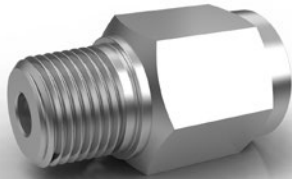

PART NO.	SNUBBERS	INLET	OUTLET	MAX PRESSURE
35-002-001	316 STAINLESS STEEL RAY SNUBBER	1/2" NPTM	1/2" NPTF	15K psi (1034 bar)

15K psi PRESSURE REGULATING VALVE

Assembly No. 65-110-015

A Pressure Regulating Valve (PRV), also called a By-Pass Valve, is used on both diesel and electric pumping units to divert a portion of the flow to a low pressure outlet. It is really a hand-adjusted needle valve and can be used to control pressure when the application requires a flow at the low end of the pumping unit operating range. For electric units a PRV is required because the speed of the drive is not adjustable.

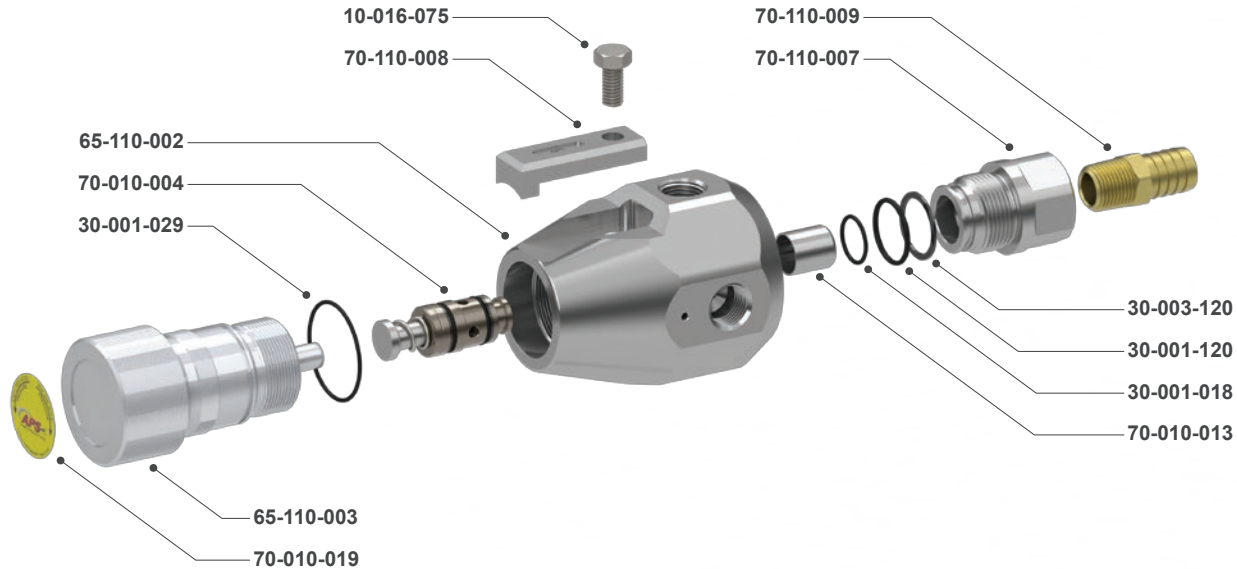

PART NO.	BILL OF MATERIALS (Assembly No. 65-110-015)	QUANTITY
10-016-075	3/8"-16 X 3/4" STAINLESS STEEL HEX HEAD BOLT	1
30-001-018	2-018 BUNA-N 90 DURO O-RING (GDWJ TYPE: 22-17046)	1
30-001-029	2-029 BUNA-N 90 DURO O-RING	1
30-001-120	2-120 BUNA-N 90 DURO O-RING (GDWJ TYPE: 77800026)	1
30-003-120	8-120 BUNA-N 90 DURO BACK-UP RING	1
65-110-002	15K J/S TYPE PRESSURE REGULATING VALVE BODY	1
65-110-003	15/20K J/S TYPE PRESSURE REGULATING VALVE ADJUSTER HANDLE	1
70-010-004	15K FLOW DIVIDER VALVE / PRESSURE REGULATING VALVE CARTRIDGE ASSEMBLY (J/S TYPE: 50234)	1
70-010-013	15/20K FLOW DIVIDER VALVE DIFFUSER (J/S TYPE: 52201)	1
70-010-019	FLOW DIVIDER VALVE / PRESSURE REGULATING VALVE ADJUSTER KNOB DECAL	1
70-110-007	1/2" NPTF 15K J/S TYPE FLOW DIVIDER VALVE DISCHARGE ADAPTER	1
70-110-008	J/S TYPE PRESSURE REGULATING VALVE HOLD DOWN CLAMP	1
70-110-009	1/2" NPTM X 3/4" BRASS HOSE BARB FITTING	1

15K psi PRESSURE REGULATING VALVE

Assembly No. 65-110-015

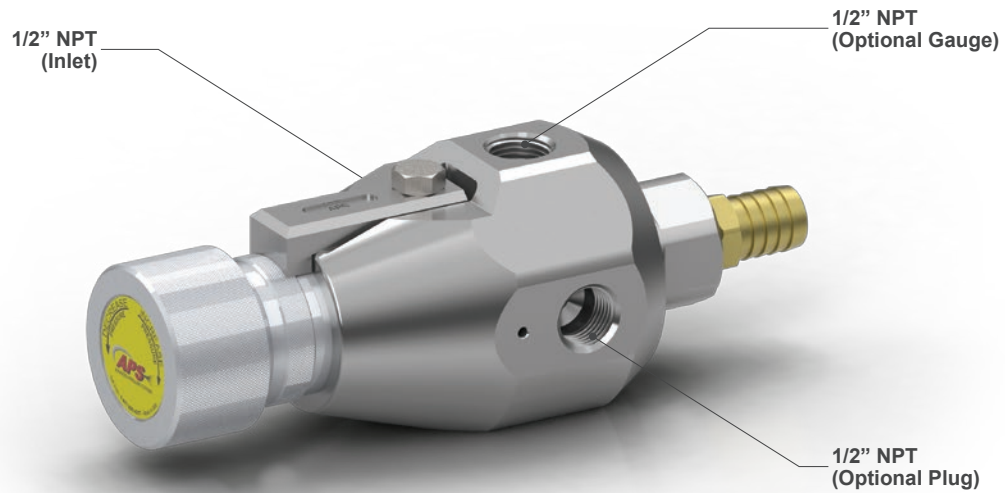

Paired for 15K psi Pressure Regulating Valve...



20-018-005

1/2" NPT STAINLESS STEEL HEX HEAD PLUG
(15K MAWP)



35-001-003

4" STAINLESS STEEL 0-20K RANGE (15K MAWP) GF 1/2" NPTM
BOTTOM MOUNT PRESSURE GAUGE



35-002-001

1/2" NPTM X 1/2" NPTF 15K 316 STAINLESS STEEL RAY SNUBBER
(GDWJ TYPE: 77512021)



70-010-004

15K FDV/PRV CARTRIDGE ASSEMBLY
(J/S TYPE: 50234)

20K psi PRESSURE REGULATING VALVE

Assembly No. 65-120-015

A Pressure Regulating Valve (PRV), also called a By-Pass Valve, is used on both diesel and electric pumping units to divert a portion of the flow to a low pressure outlet. It is really a hand-adjusted needle valve and can be used to control pressure when the application requires a flow at the low end of the pumping unit operating range. For electric units a PRV is required because the speed of the drive is not adjustable.

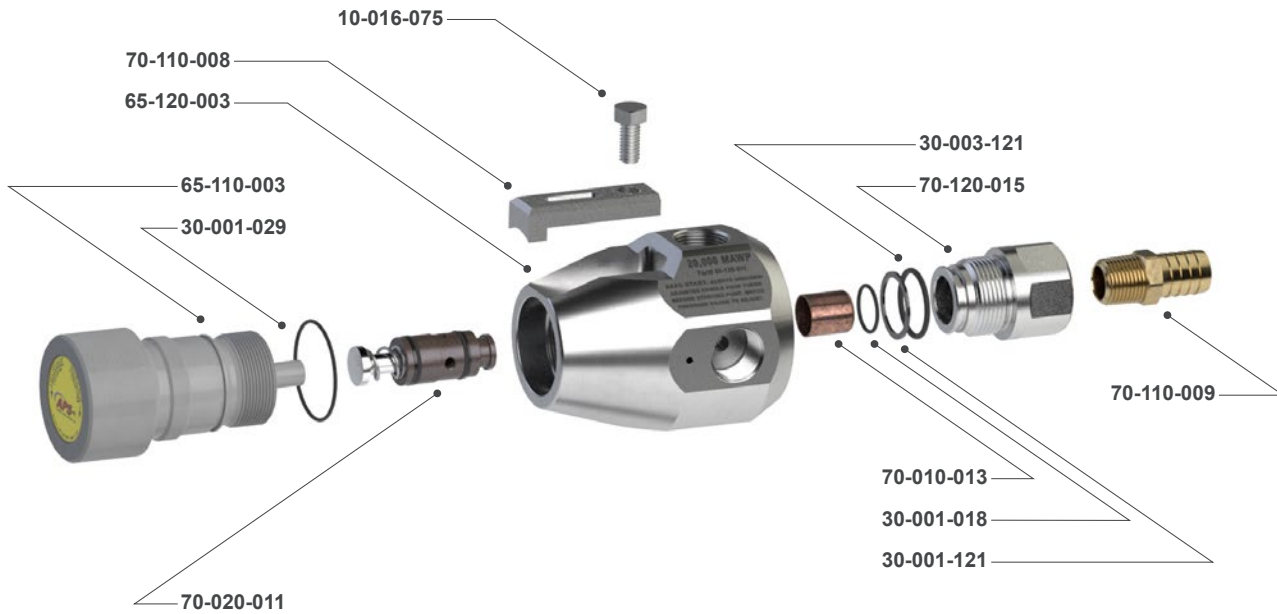

PART NO.	BILL OF MATERIALS (Assembly No. 65-120-015)	QUANTITY
10-016-075	3/8"-16 X 3/4" STAINLESS STEEL HEX HEAD BOLT	1
30-001-018	2-018 BUNA-N 90 DURO O-RING (GDWJ TYPE: 22-17046)	1
30-001-029	2-029 BUNA-N 90 DURO O-RING	1
30-001-121	2-121 BUNA-N 90 DURO O-RING	1
30-003-121	PARBAK BACK-UP RING	1
65-110-003	15/20K J/S TYPE PRESSURE REGULATING VALVE ADJUSTER HANDLE	1
65-120-003	20K J/S TYPE PRESSURE REGULATING VALVE BODY	1
70-010-013	15/20K FLOW DIVIDER VALVE DIFFUSER (J/S TYPE: 52201)	1
70-010-019	FLOW DIVIDER VALVE / PRESSURE REGULATING VALVE ADJUSTER KNOB DECAL	1
70-020-011	20K FLOW DIVIDER VALVE / PRESSURE REGULATING VALVE CARTRIDGE ASSEMBLY (J/S TYPE: 52255)	1
70-110-008	J/S TYPE PRESSURE REGULATING VALVE HOLD DOWN CLAMP	1
70-110-009	1/2" NPTM X 3/4" BRASS HOSE BARB FITTING	1
70-120-015	1/2" NPTF 20K DISCHARGE ADAPTER (J/S TYPE: 54587)	1

20K psi PRESSURE REGULATING VALVE

Assembly No. 65-120-015

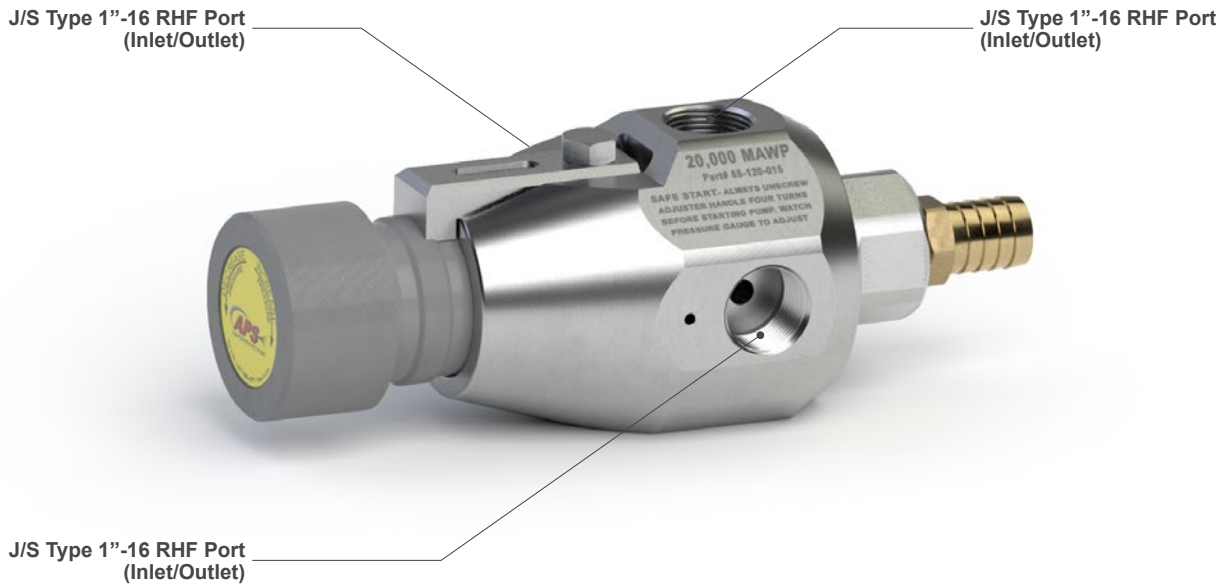

Paired for 20K psi Pressure Regulating Valve...

35-001-025
4" STAINLESS STEEL 0-40K RANGE GF 9/16" HP TUBE NIPPLE
BOTTOM MOUNT PRESSURE GAUGE (NUOVA FIMA)

65-120-005
1"-16 RHM X 9/16" MPF 20K ADAPTER W/ SEAL ASSEMBLY
(J/S TYPE: 52044)

65-120-007
1"-16 RHM J/S TYPE PLUG W/ SEAL ASSEMBLY
(J/S TYPE 52076)

65-120-037
1"-16 RHM X 1"-16 RHM 22K ADAPTER W/ SEAL ASSEMBLY
& JAM NUT (J/S TYPE: 52209)

40K psi PRESSURE REGULATING VALVE

Assembly No. 65-040-010

A Pressure Regulating Valve (PRV) is used on both diesel and electric pumping units to divert a portion of the flow to a low pressure outlet. It is a hand-adjusted needle valve and can be used to control pressure when the application requires flow at the low end of the pumping unit operating range. For electric units a PRV is required because the speed of the drive is not adjustable.

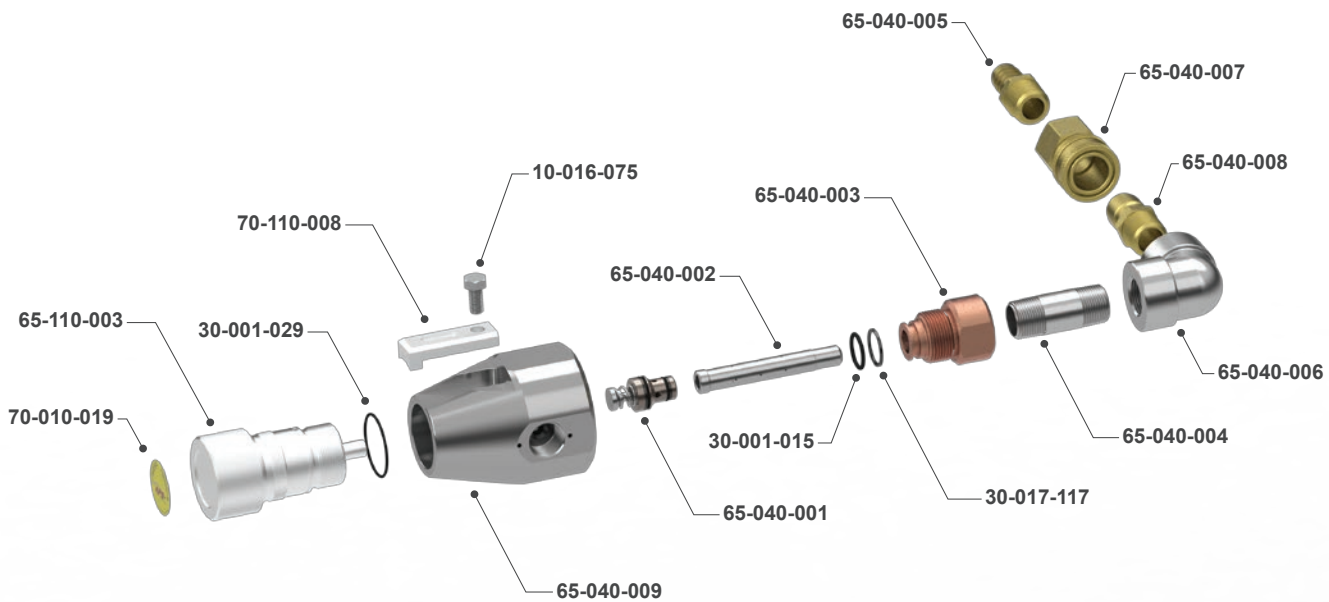

PART NO.	BILL OF MATERIALS (Assembly No. 65-040-010)	QUANTITY
10-016-075	3/8"-16 X 3/4" STAINLESS STEEL HEX HEAD BOLT	1
30-001-015	2-015 BUNA-N 90 DURO O-RING	1
30-001-029	2-029 BUNA-N 90 DURO O-RING	1
30-010-117	2-117 BUNA-N 90 DURO O-RING	1
30-017-117	015 DELRIN SPLIT BACK-UP RING	1
65-040-001	40K PRESSURE REGULATING VALVE CARTRIDGE ASSEMBLY (J/S TYPE: 53725)	1
65-040-002	40K PRESSURE REGULATING VALVE DISCHARGE DIFFUSER (J/S TYPE: 53726)	1
65-040-003	40K PRESSURE REGULATING VALVE DISCHARGE ADAPTER	1
65-040-004	3/4" NPT STAINLESS STEEL NIPPLE	1
65-040-005	3/4" NPTM X 3/4" HOSE BARB FITTING	1
65-040-006	3/4"NPT X 3/4" NPT CAST STAINLESS STEEL PRESSURE REGULATING VALVE ELBOW	1
65-040-007	3/4" NPTF PARKER QUICK DISCONNECT	1
65-040-008	3/4" NPTM PARKER QUICK DISCONNECT	1
65-040-009	40K PRESSURE REGULATING VALVE DISCHARGE BODY (J/S TYPE: 53713)	1
65-110-003	15/20K J/S TYPE PRESSURE REGULATING VALVE ADJUSTER HANDLE (J/S TYPE: 52144)	1
70-010-019	FLOW DIVIDER VALVE / PRESSURE REGULATING VALVE ADJUSTER KNOB DECAL	1
70-110-008	J/S TYPE PRESSURE REGULATING VALVE HOLD DOWN CLAMP	1

40K psi PRESSURE REGULATING VALVE

Assembly No. 65-040-010

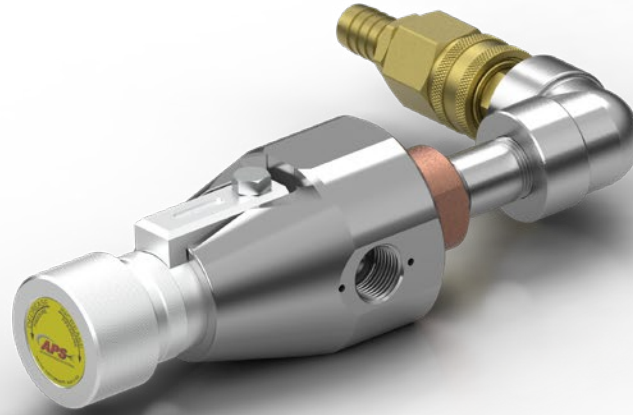

Paired for 40K psi Pressure Regulating Valve...



60-070-057

5MM TYPE M X 1"-12 J/S TYPE 40K STAINLESS STEEL PORT
ADAPTER (J/S PORT TYPE: 53571)

65-040-016

1"-12 40K J/S TYPE PORT PLUG
(J/S TYPE: 53573)

65-040-021

1"-12 40K WP J/S PORT MALE X 1"-12 J/S PORT MALE
TORPEDO ADAPTER (J/S TYPE: 53735)

15K psi FLOW DIVIDER VALVE

Assembly No. 70-022-001

The Flow Divider Valve (FDV) is for applications where two dump style guns are to be operated from one pump. The FDV will maintain full pressure to either gun when the other gun is dumping. When both guns are operating, the flow and pressure will be unaffected. These valves are made with rugged construction and are easy to set up. The only wear part is a cartridge, which can be quickly changed in the field.

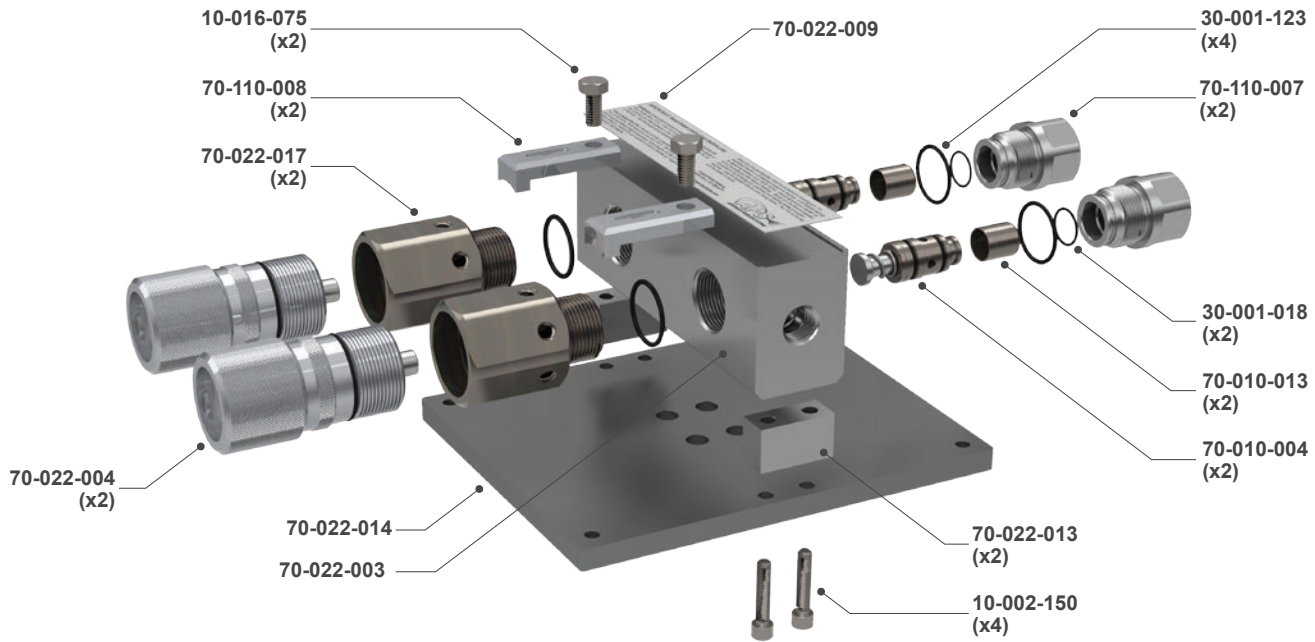

PART NO.	BILL OF MATERIALS (Assembly No. 70-022-001)	QUANTITY
10-002-150	5/16"-18 X 1-1/2" LONG STAINLESS STEEL SHCS SCREW	4
10-016-075	3/8"-16 X 3/4" STAINLESS STEEL HEX HEAD BOLT	2
30-001-018	2-018 BUNA-N 90 DURO O-RING (GDWJ TYPE: 22-17046)	2
30-001-123	2-123 BUNA-N 90 DURO O-RING	4
70-010-004	15K FDV/PRV CARTRIDGE ASSEMBLY (J/S TYPE: 50234)	2
70-010-013	15/20K FLOW DIVIDER VALVE DIFFUSER (J/S TYPE: 52201)	2
70-022-003	15K J/S TYPE MACHINED FLOW DIVIDER VALVE MANIFOLD (J/S TYPE: 51767)	1
70-022-004	15/20K FLOW DIVIDER VALVE ADJUSTER ASSEMBLY (J/S TYPE: 50900)	2
70-022-009	15/20K J/S TYPE FLOW DIVIDER VALVE INSTRUCTION NAME PLATE	1
70-022-013	15/20K J/S TYPE FLOW DIVIDER VALVE BASE PLATE RISER BLOCK	2
70-022-014	15/20K J/S TYPE FLOW DIVIDER VALVE BASE PLATE	1
70-022-017	15K J/S TYPE FLOW DIVIDER VALVE ADJUSTER ADAPTER (J/S TYPE: 517690)	2
70-110-007	1/2" NPTF J/S TYPE 15K FLOW DIVIDER VALVE DISCHARGE ADAPTER	2
70-110-008	J/S TYPE PRESSURE REGULATING VALVE HOLD DOWN CLAMP	2

15K psi FLOW DIVIDER VALVE

Assembly No. 70-022-001

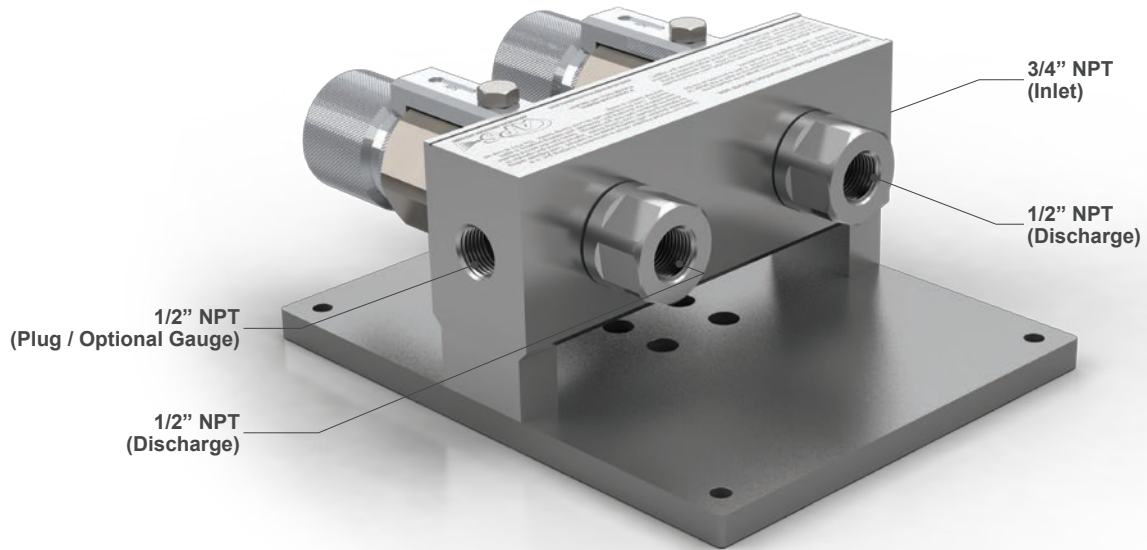

Paired for 15K psi Flow Divider Valve...



20-011-008

1/2" NPTM X 1/2" NPTM (15K MAWP) HEX NIPPLE
(GDWJ TYPE: 3432509) (J/S TYPE: 50488)

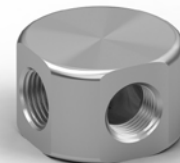

20-004-010

1/2" NPT 90° WAFER ELBOW
(15K MAWP)



20-018-005

1/2" NPT STAINLESS STEEL HEX HEAD PLUG
(15K MAWP)



35-001-003

4" 0-20K RANGE STAINLESS STEEL GF 1/2" NPTM BOTTOM
MOUNT PRESSURE GAUGE (15K MAWP)

20K psi FLOW DIVIDER VALVE

Assembly No. 70-032-001

Flow Divider Valves (FDV) are for applications where two dump style guns are to be operated from one pump. When both guns are operating, the flow and pressure will be unaffected. These valves are made with rugged construction and are easy to set up. The only wear part is a cartridge, which can be quickly changed in the field.

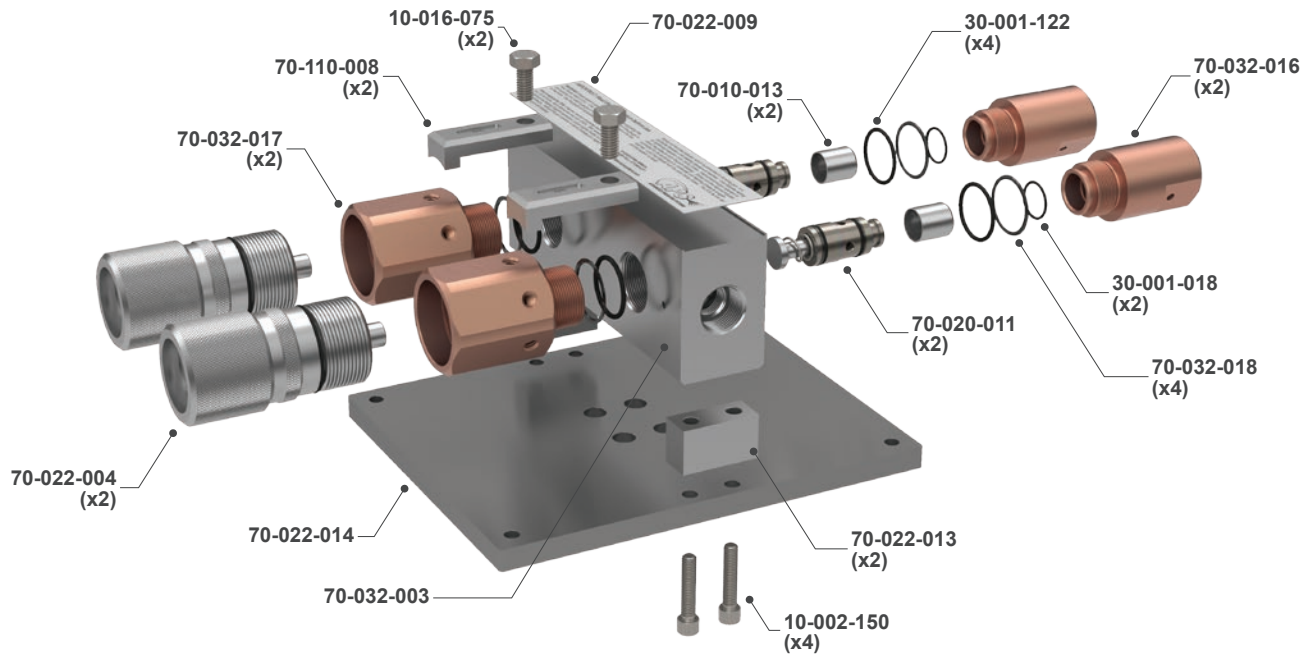

PART NO.	BILL OF MATERIALS (Assembly No. 70-032-001)	QUANTITY
10-002-150	5/16"-18 X 1-1/2" LONG STAINLESS STEEL SHCS SCREW	4
10-016-075	3/8"-16 X 3/4" STAINLESS STEEL HEX HEAD BOLT	2
30-001-018	2-018 BUNA-N 90 DURO O-RING (GDWJ TYPE: 22-17046)	2
30-001-122	2-122 BUNA-N 90 DURO O-RING (J/S TYPE: 26776)	4
70-010-013	15/20K FLOW DIVIDER VALVE DIFFUSER (J/S TYPE: 52201)	2
70-020-011	20K FLOW DIVIDER VALVE / PRESSURE REGULATING VALVE CARTRIDGE ASSEMBLY (J/S TYPE: 52255)	2
70-022-004	15/20K FLOW DIVIDER VALVE ADJUSTER ASSEMBLY (J/S TYPE: 50900)	2
70-022-009	15/20K J/S TYPE FLOW DIVIDER VALVE INSTRUCTION NAME PLATE	1
70-022-013	15/20K J/S TYPE FLOW DIVIDER VALVE BASE PLATE RISER BLOCK	2
70-022-014	15/20K J/S TYPE FLOW DIVIDER VALVE BASE PLATE	1
70-032-003	20K J/S TYPE MACHINED FLOW DIVIDER VALVE MANIFOLD (J/S TYPE: 52206)	1
70-032-016	20K J/S HIGH VOLUME FLOW DIVIDER VALVE DISCHARGE ADAPTER (3/4" MPF PORT) (J/S TYPE: J55802)	2
70-032-017	20K FLOW DIVIDER VALVE ADJUSTER ADAPTER (J/S TYPE: 52221)	2
70-032-018	FLOW DIVIDER VALVE-20 DELRIN SPLIT BACK-UP RING (J/S)	4
70-110-008	J/S TYPE PRESSURE REGULATING VALVE HOLD DOWN CLAMP	2

20K psi FLOW DIVIDER VALVE

Assembly No. 70-032-001

3/4" MPF
(Inlet/Outlet)

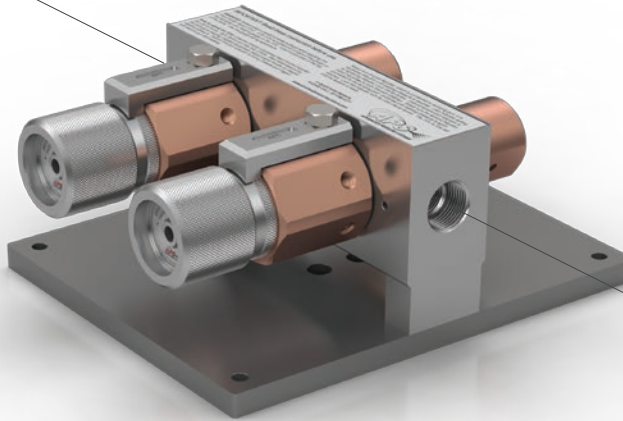

3/4" MPF
(Inlet/Outlet)

Paired for 20K psi Flow Divider Valve...



21-004-004

3/4" MEDIUM PRESSURE PLUG
20K



21-007-004

9/16" MP M X 8MM (3/4"-16) TYPE M MALE 20K STAINLESS STEEL
ADAPTER (AF 061-MP9) (GDWJ TYPE: 77211023)



21-007-008

3/4" MPM X 13MM (1"-12) TYPE M MALE 20K ADAPTER
(GDWJ TYPE: 77211026 OR AF 063-MP12)



35-001-025

4" 0-40K RANGE (20K MAWP) STAINLESS STEEL GF 9/16" HP TUBE
NIPPLE BOTTOM MOUNT PRESSURE GAUGE (NUOVA FIMA)

40K psi TRI-MODE TUMBLEBOX w/ DUAL AIR CONTROL HOSE ASSEMBLY

Assembly No. 60-070-076

The 40K Tri-Mode Valve, commonly called a Tumblebox, has been developed after extensive research aimed at identifying the features that contractors and end users need most. The air side incorporates a robust, easy-to-operate shut-off valve, and a large, easy-to-read, horizontally mounted gauge that is protected by a heavy rubber buffer. The shuttle valve is a simple cartridge type design, which is easy to service and replace.

40K psi TRI-MODE TUMBLEBOX w/ DUAL AIR CONTROL HOSE ASSEMBLY

Assembly No. 60-070-076

JETSTREAM TYPE PORT FITTINGS

The port type connection is often found on Pressure Regulating Valves and Jetstream Type Manifolds.



PART NO.	JETSTREAM TYPE PORT FITTINGS	INLET	OUTLET	MAX PRESSURE
65-120-026	J/S TYPE ADAPTER ASSEMBLY W/O SEAL	1"-16 RHM	1/2" NPTM	15K psi (1034 bar)
65-120-027	J/S TYPE ADAPTER ASSEMBLY W/ SEAL	1"-16 RHM	1/2" NPTM	15K psi (1034 bar)
65-120-003	J/S TYPE PRESSURE REGULATING VALVE BODY	--	--	20K psi (1379 bar)
65-120-011	FACE SEAL ASSEMBLY (J/S TYPE: 52040)	--	--	20K psi (1379 bar)
65-120-015	J/S TYPE PRESSURE REGULATING VALVE ASSEMBLY (J/S TYPE: 54592)	--	--	20K psi (1379 bar)
65-120-016	J/S TYPE ADAPTER ASSEMBLY W/O SEAL	1"-16 RHM	5MM (9/16"-18) TYPE M	20K psi (1379 bar)
65-120-017	J/S TYPE ADAPTER ASSEMBLY W/O SEAL	1"-16 RHM	8MM (3/4"-16) TYPE M	20K psi (1379 bar)
65-120-018	J/S TYPE ADAPTER ASSEMBLY W/O SEAL	1"-16 RHM	13MM (1"-12) TYPE M	20K psi (1379 bar)
65-120-020	J/S TYPE ADAPTER ASSEMBLY W/ SEAL (J/S TYPE: 54739)	1"-16 RHM	5MM (9/16"-18) TYPE M	20K psi (1379 bar)
65-120-021	J/S TYPE ADAPTER ASSEMBLY W/ SEAL (J/S TYPE: 54741)	1"-16 RHM	8MM (3/4"-16) TYPE M	20K psi (1379 bar)
65-120-022	J/S TYPE ADAPTER ASSEMBLY W/ SEAL (J/S TYPE 53284)	1"-16 RHM	13MM (1"-12) TYPE M	20K psi (1379 bar)
65-120-023	J/S TYPE ADAPTER ASSEMBLY W/ SEAL (J/S TYPE: 54749)	1"-16 RHM	20MM (1-5/16"-12) TYPE M	20K psi (1379 bar)
65-120-024	J/S TYPE ADAPTER ASSEMBLY (J/S TYPE: 54744)	1"-16 RHF	8MM (3/4"-16) TYPE M	20K psi (1379 bar)
65-120-025	2.5" LONG J/S TYPE ADAPTER ASSEMBLY W/O SEAL	1"-16 RHM	1"-16 RHF	20K psi (1379 bar)
65-120-028	J/S TYPE ADAPTER ASSEMBLY W/ SEAL	1"-16 RHM	M24 X 1.5M	20K psi (1379 bar)
65-120-031	J/S TYPE ADAPTER ASSEMBLY W/ SEAL (J/S TYPE: 54737)	1"-16 RHM	3/4" MPF	20K psi (1379 bar)
65-120-032	J/S TYPE ADAPTER ASSEMBLY W/ SEAL (J/S TYPE: 52354)	1"-16 RHM	9/16" MPM	20K psi (1379 bar)
65-120-037	J/S TYPE ADAPTER ASSEMBLY W/ SEAL & JAM NUT (J/S TYPE: 52209)	1"-16 RHM	1"-16 RHM	22K psi (1517 bar)
65-120-004	J/S TYPE BUSHING W/O SEAL ASSEMBLY	1"-16 RHM	9/16" MPF	--
65-120-005	J/S TYPE ADAPTER W/ SEAL ASSEMBLY (J/S TYPE: 52044)	1"-16 RHM	9/16" MPF	--
65-120-006	J/S TYPE PLUG W/O SEAL ASSEMBLY	1"-16 RHM	--	--
65-120-007	J/S TYPE PLUG W/O SEAL ASSEMBLY (J/S TYPE: 52076)	1"-16 RHM	--	--
65-120-008	J/S TYPE HIGH PRESSURE STAINLESS STEEL SEAL HOUSING	--	--	--
65-120-009	0.561" O.D. X 0.432" I.D. ANTI-EXTRUSION SPACER	--	--	--
65-120-035	2.5" LONG J/S TYPE ADAPTER ASSEMBLY W/ SEAL	1"-16 RHM	1"-16 RHF	--

LUBRICANTS

Our wide selection of lubricants makes assembling leak-tight connections even easier. Rated for use with stainless steel, titanium, aluminum, nickel-based and high-temperature alloys.

Brands:

- Blue Goop™
- Loctite®
- Jet-Lube Marine Moly™
- Yellow Lube® Waterjet Thread Protection



PART NO.	LUBRICANTS
24-001-001	BLUE GOOP, THREAD LUBRICANT 2 OZ. TUBE (GP 043)
24-001-002	NICKEL BASED ANTI-SEIZE, LOCTITE-1 LB. BRUSH CAN
24-001-003	THREAD SEALANT, LOCTITE-567 250 ML TUBE FOR SS FITTINGS
24-001-009	ANTI-SEIZE, JET-LUBE MOLYBDENUM DISULFIDE BASED (8 OZ. BRUSH CAN)
24-001-010	ANTI-SEIZE, JET-LUBE MOLYBDENUM DISULFIDE BASED (1 LB. BRUSH CAN)
24-001-011	YELLOW LUBE, THREAD LUBRICANT 6 OZ. TUBE (USE 24-001-027)

GREASE

Brands:

- **Clover Compound:** Specially formulated for lapping engine valves for optimum performance
 - **Premalube:** Multi-purpose, heavy load, extreme pressure, high temperature grease in an aluminum complex base with Moly and graphite



PART NO.	GREASE
24-001-013	COMPOUND, CLOVER 600 GRIT VERY FINE LAPPING & POLISHING SILICON CARBIDE GREASE 16 OZ.
24-001-014	COMPOUND, CLOVER 600 GRIT VERY FINE LAPPING & POLISHING SILICON CARBIDE GEL 1 LB.
24-001-015	GREASE, PREMALUBE 4099 (TUBE)

OILS

Use to lubricate bearings, cables, chains, nuts, bolts, rollers, hinges, sockets, pulleys and sliding surfaces.

Brands:

- **Anti-Seize Technology:** A blend of oils that clean, lubricate and recondition air operated power tools, air pumps, pneumatic devices and pneumatic systems
- **Tap Magic:** An ozone-friendly formula that provides outstanding performance on all cuts and all metals - even hard metals such as stainless steel.



PART NO.	OILS
24-001-020	OIL, AIR TOOL (16 OZ.)
24-001-021	TAP MAGIC, 4 OZ. SPOUT-TOP CAN

PRECISION MEASURING TOOLS

Used to determine small hole sizes / gage slots / find hole distances.



PART NO.	PRECISION MEASURING TOOLS
15-099-000	PIN GAGE SET, 0.011" - 0.060" (MINUS 0.0002") VERMONT
15-099-001	PIN GAGE SET, 0.0115" - 0.0605" (MINUS 0.0002") VERMONT
15-099-002	PIN VISE, W/ COLLET (0.000" - 0.055") RANGE
15-099-003	PIN VISE, W/ COLLET (0.025" - 0.075") RANGE

TOOL CLEANERS

Tip cleaners and micro pick set.

Brands:

- **Wypro:** Primarily designed for the cleaning of welding and cutting tips, they also can be used to clean sprinkler and shower heads, gas range burners and desoldering tools, and to allow for precision hole deburring
- **Griot's Garage:** Ideal for positioning, adjusting and retrieving small parts, separating wires, removing small fuses and O-rings, as well as cleaning out gummed-up grooves, channels or conduits



PART NO.	TOOL CLEANERS
15-099-125	TIP CLEANER, WYPO STANDARD (SIZES #6 - #26) (SIZES 0.018" - 0.102")
15-099-126	MICRO PICK SET, 5 PIECES W/ POUCH

MACHINE THREADING DIES

Used to create or rethread external threads.



PART NO.	MACHINE THREADING DIES
24-018-043	DIE, 1/4"-28 LH X 1-1/2" O.D. PREMIUM THREAD
24-018-044	DIE, 3/8"-24 LH X 1-1/2" O.D. PREMIUM THREAD
24-018-045	DIE, 9/16"-18 LH X 1-1/2" O.D. PREMIUM THREAD (GDWJ TYPE: 77513132)
24-018-048	DIE, 1/4"-28 RH X 1-1/2" O.D. PREMIUM OSG THREAD
24-018-049	DIE, 3/8"-24 RH X 1-1/2" O.D. PREMIUM THREAD
24-018-050	DIE, 9/16"-18 RH X 1-1/2" O.D. PREMIUM OSG THREAD (GDWJ TYPE: 77513142)

CONING & THREADING TOOL KITS

MaxPro Technologies offers a complete line of coning and threading tool kits for manually coning and threading 1/4" O.D. to 9/16" O.D. tubing.

There are three different tool kit versions: the "Medium" Pressure, "High" Pressure, and the "Complete Kit" that contains both the Medium and the High Pressure tools. All items are conveniently packaged in a sturdy hand carry tool case with removable top tray. The unique coning and threading tool designs allows for interchange ability between components, eliminating multiple tool inventories.



PART NO.	CONING & THREADING TOOL KITS
24-117-010	1/4" HP MAXIMATOR CONING TOOL ASSEMBLY W/ COLLET & BLADE
24-117-011	3/8" HP MAXIMATOR CONING TOOL ASSEMBLY W/ COLLET & BLADE
24-117-012	9/16" HP MAXIMATOR CONING TOOL ASSEMBLY W/ COLLET & BLADE
24-119-007	1/4" MP/HP MAXIMATOR THREADING TOOL ASSEMBLY W/ LH DIE & BUSHING
24-119-008	3/8" MP/HP MAXIMATOR THREADING TOOL ASSEMBLY W/ LH DIE & BUSHING
24-119-009	9/16" MP/HP MAXIMATOR THREADING TOOL ASSEMBLY W/ LH DIE & BUSHING

15K psi RUPTURE DISC HOLDER w/ SAFETY SHROUD

Assembly No. 35-008-025

A rupture disc is an essential component in any system that contains a positive displacement pump. It provides protection against excessive pressure building up in the water blasting equipment connected to a pump. Our rugged, compact rupture disc holder offers safety features to prevent the use of coins or other disc substitutes, which may prove dangerous to operators or cause damage to the blasting equipment. The domed deflector minimizes spray in the event of a disc rupturing, and it is simple to replace a disc.

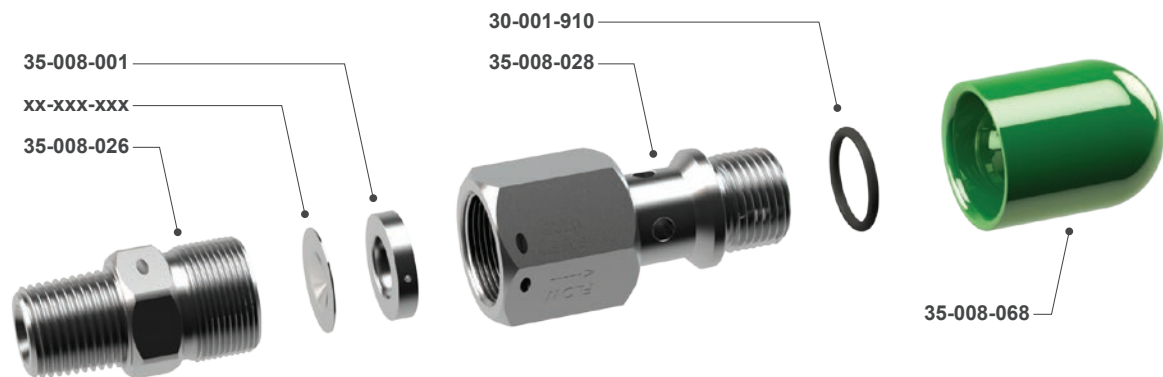

PART NO.	RUPTURE DISC HOLDER
30-001-910	3-910 BUNA-N 90 DURO O-RING
35-008-000	1/2" NPTM 15K COMPLETE RUPTURE DISC ASSEMBLY (GDWJ TYPE: 77512042)
35-008-001	1/2" 15K RUPTURE DISC HOLD DOWN RING (GDWJ TYPE: 77512009)
35-008-026	1/2" NPTM 15K RUPTURE DISC HOLDER BODY
35-008-028	1/2" 15K RUPTURE DISC HOLDER HOLD DOWN NUT
35-008-068	1/2" 15K RUPTURE DISC SAFETY SHROUD (GREEN)
xx-xxx-xxx	REFER TO RUPTURE DISC TABLE ON THE RIGHT

PART NO.	REPLACEMENT RUPTURE DISCS
35-005-030	1/2" STD 3.0K BURST RUPTURE DISC (0.875" DIAMETER)
35-005-040	1/2" STD 4.0K BURST RUPTURE DISC (0.875" DIAMETER)
35-005-055	1/2" STD 5.5K BURST RUPTURE DISC (0.875" DIAMETER)
35-005-065	1/2" STD 6.5K BURST RUPTURE DISC (0.875" DIAMETER)
35-005-070	1/2" STD 7.0K BURST RUPTURE DISC (0.875" DIAMETER)
35-005-075	1/2" STD 7.5K BURST RUPTURE DISC (0.875" DIAMETER)
35-005-088	1/2" STD 8.8K BURST RUPTURE DISC (0.875" DIAMETER)
35-005-100	1/2" STD 10.0K BURST RUPTURE DISC (0.875" DIAMETER)
35-005-105	1/2" STD 10.5K BURST RUPTURE DISC (0.875" DIAMETER)
35-005-117	1/2" STD 11.7K BURST RUPTURE DISC (0.875" DIAMETER)
35-005-125	1/2" STD 12.5K BURST RUPTURE DISC (0.875" DIAMETER) (GDWJ TYPE: 3132001125 OR 77512068-12.5K)
35-005-148	1/2" STD 14.8K BURST RUPTURE DISC (0.875" DIAMETER)
35-005-175	1/2" STD 17.5K BURST RUPTURE DISC (0.875" DIAMETER) (GDWJ TYPE: 3132001175 OR 77512069-17.5K)
35-005-188	1/2" STD 18.8K BURST RUPTURE DISC (0.875" DIAMETER) (GDWJ TYPE: 3132001188)

40K psi ARTICULATED FLEX LANCE SAFETY STOP

Assembly No. 36-015-089

The Articulated Flex Lance Safety Stop takes the Hand-Held Flex Lance Safety Grip to the next level. This versatile lance stop/anti-withdrawal device attaches easily to the tube sheet for safer pipe cleaning operations. It features adaptability to vertical or horizontal applications, and its wide range of expansion accommodates any size of tube sheet. Construction is galvanized steel with aluminum handles and includes a Lexan® splash guard.

The stops for six sizes of lances are provided by a quick-change insert, which is built in to the design, eliminating the problem of lost lance stops and makes changing to a different diameter quick and easy.

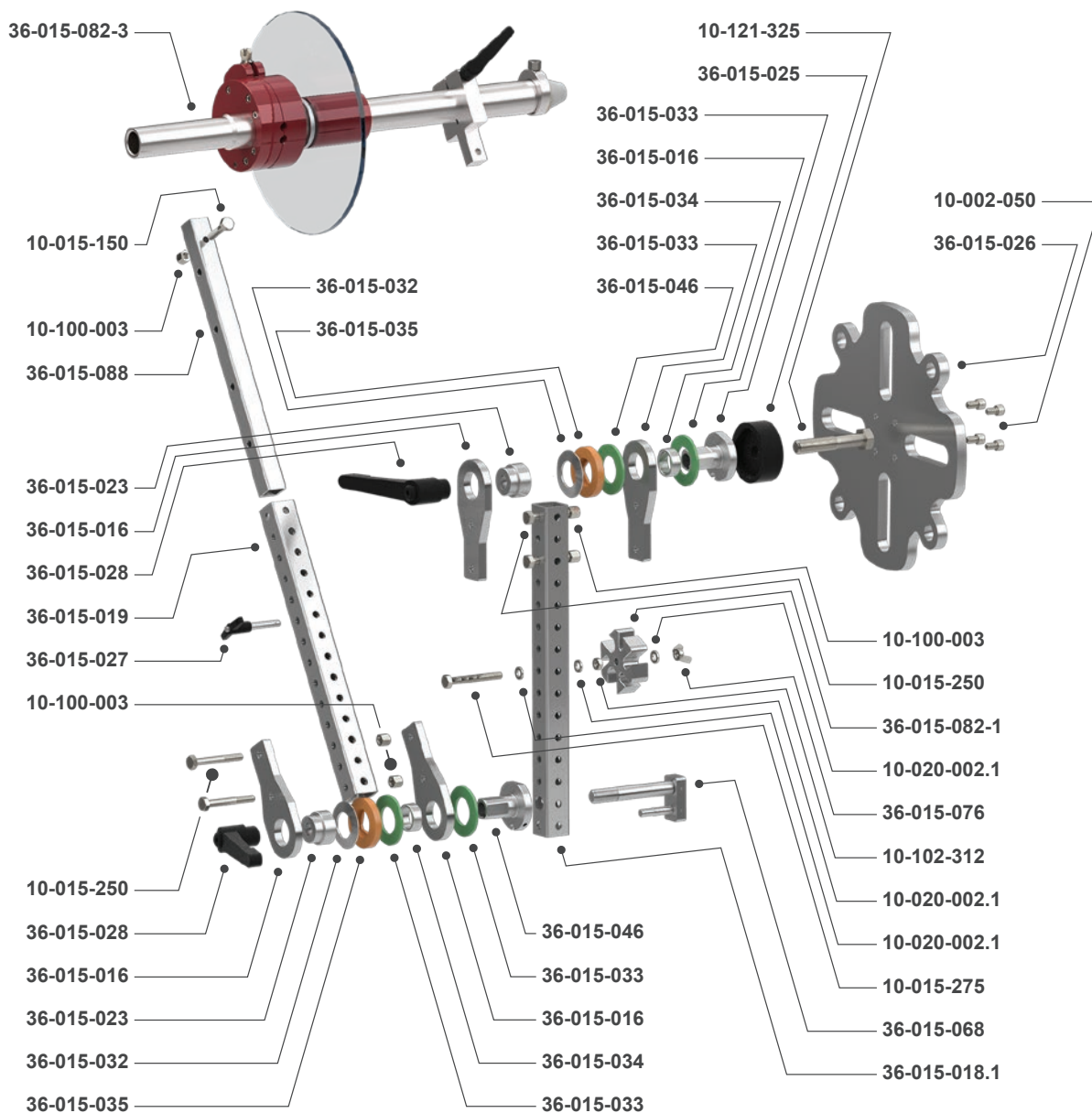

40K psi ARTICULATED FLEX LANCE SAFETY STOP

Assembly No. 36-015-089



PART NO.	BILL OF MATERIALS (Assembly No. 36-015-089)	QUANTITY
10-002-050	5/16"-18 X 1/2" LONG STAINLESS STEEL SHCS SCREW	4
10-015-150	5/16"-18 X 1-1/2" STAINLESS STEEL HEX HEAD BOLT	1
10-015-250	5/16"-18 X 2-1/2" STAINLESS STEEL HEX HEAD BOLT	4
10-020-002	5/16" STAINLESS STEEL LOCK WASHER	3
10-060-275	5/16"-18 X 2-3/4" LONG STAINLESS STEEL (FULL THREAD) TAP BOLT	1
10-100-003	5/16"-18 STAINLESS STEEL NYLON LOCK NUT	5
10-100-006	5/16"-18 316 STAINLESS STEEL JAM NUT	1
10-121-325	5/8"-11 X 3-1/4" C/S ZINC PLATED (GRADE 8) HEX HEAD BOLT	1
36-015-016	AWD PIVOT MOUNT PLATE (VL 113)	4
36-015-018.1	TELESPAR ARM ONE F/ WELDMENT ASSEMBLY (VL 115.1)	1
36-015-019	TELESPAR ARM TWO (VL 120)	1
36-015-023	TORQUE LIMITER SPACER (VL 135)	2
36-015-025	DALTON CLUTCH MOUNTING ADAPTER F/ MAIN PLATE	1
36-015-026	CHICKEN WING ADAPTER MOUNTING PLATE	1
36-015-027	5/16" X 1-1/2" LONG QUICK RELEASE PIN (VL 228)	1
36-015-028	5/8"-11 UNC THREADED ADJUSTABLE HANDLE NUT (VL 229)	2
36-015-032	TORQUE LIMITER BELLVILLE SPRING WASHER	2
36-015-033	TORQUE LIMITER FIBER WASHER	4
36-015-034	TORQUE LIMITER BEARING	2
36-015-035	ORANGE TORQUE LIMITER SPACER	5
36-015-046	AWD MODIFIED TORQUE LIMITER	2
36-015-068	PIVOT PIN & LOCKING PLATE ASSEMBLY	1
36-015-076	5/16"-18 STAINLESS STEEL WING NUT	1
36-015-082-3	VARIABLE LANCE STOP ASSEMBLY F/ CHICKEN WING (NEW)	1
36-015-088	TELESPAR EXTENSION ARM (NEW)	1

40K psi VARIABLE LANCE STOP ASSEMBLY

Assembly No. 36-015-082-3

The Variable Lance Stop Assembly attaches to the end of the arm of the Flex Lance Safety Device, commonly referred to as a Chicken Wing. It provides slotted inserts that can prevent the withdrawal of a flex lance from a tube sheet while under pressure. Two inserts are included in the assembly to cover six diameters for both Parker and Spir Star lances.

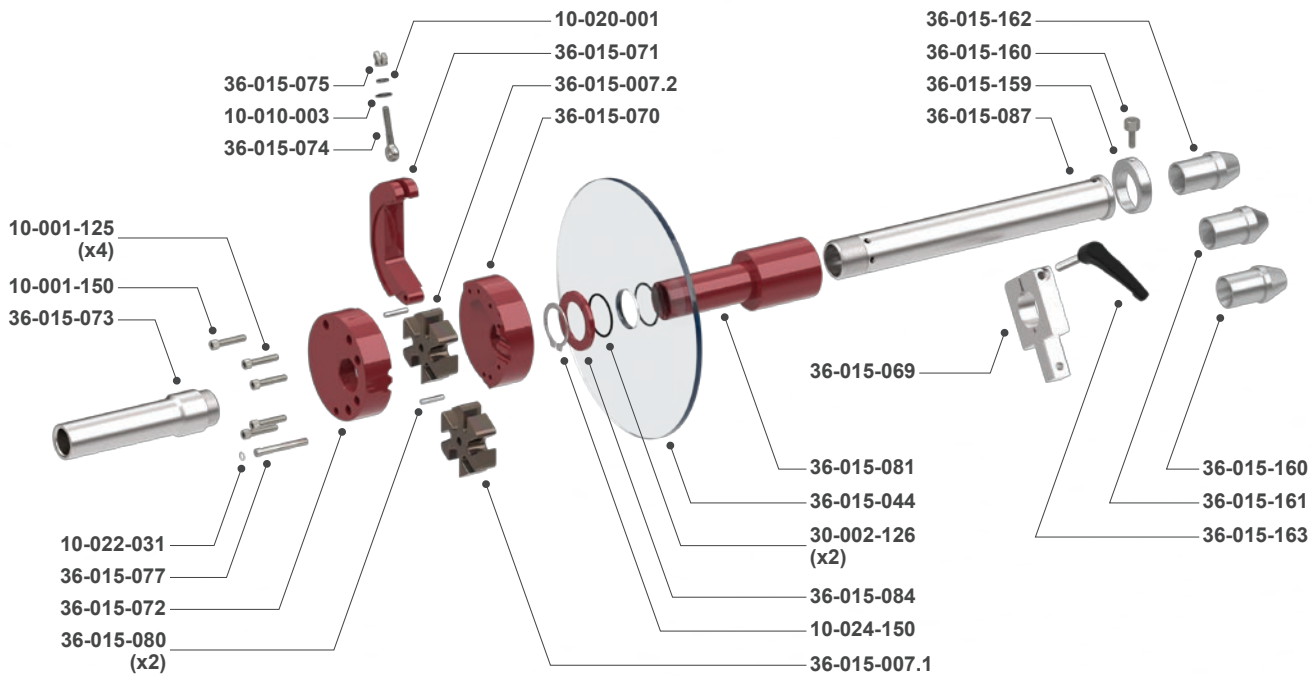

PART NO.	BILL OF MATERIALS (Assembly No. 36-015-082-3)	QUANTITY
10-001-125	1/4"-20 X 1-1/4" LONG STAINLESS STEEL SHCS SCREW (MIN YIELD 70K)	4
10-001-150	1/4"-20 X 1-1/2" LONG STAINLESS STEEL SHCS SCREW (MIN YIELD 70K)	1
10-010-003	1/4" FLAT STAINLESS STEEL WASHER	1
10-020-001	1/4" STAINLESS STEEL LOCK WASHER	1
10-022-031	TRUARC N5000-31 SS (INTERNAL) RETAINING RING	1
10-024-150	EXTERNAL STAINLESS STEEL RETAINING RING (5100-150)	1
30-002-126	2-126 BUNA-N 70 DURO O-RING	2
36-015-007.1	STAINLESS STEEL PARKER MULTIPLE LANCE STOP INSERT	1
36-015-007.2	SPIR STAR MULTIPLE LANCE STOP INSERT	1
36-015-031	5/16"-18 X 1.96" LONG THREAD ADJUSTABLE HANDLE (HRS 530)	1
36-015-044	1.500" SIZE SPLASH SHIELD	1
36-015-069	CHICKEN WING CLAMP (NEW STYLE)	1
36-015-070	LANCE BODY STOP (PART 1)	1
36-015-071	LANCE STOP HOLDER LATCH	1
36-015-072	LANCE BODY STOP (PART 2)	1

40K psi VARIABLE LANCE STOP ASSEMBLY

Assembly No. 36-015-082-3

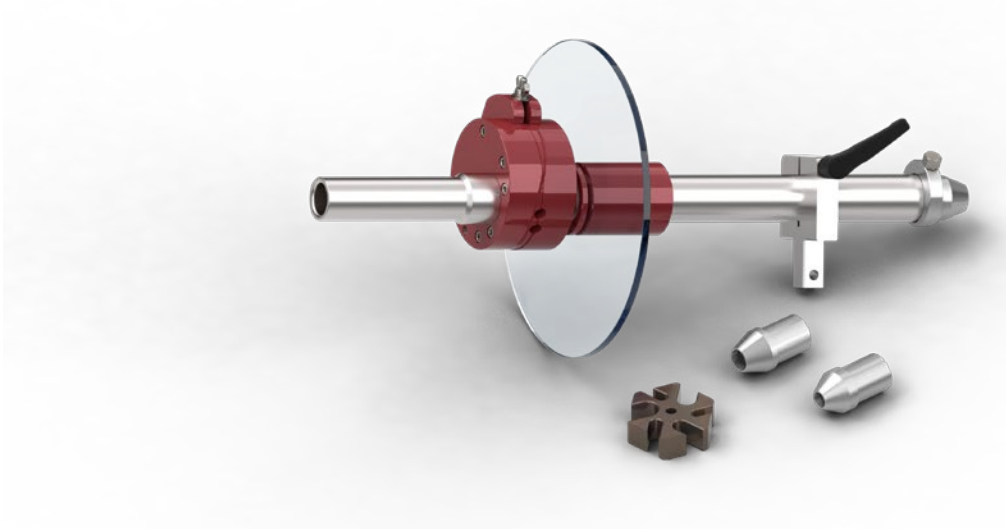

PART NO.	BILL OF MATERIALS (Assembly No. 36-015-082-3... Continued)	QUANTITY
36-015-073	LANCE GUIDE TUBE	1
36-015-074	1/4"-20 STAINLESS STEEL LATCH EYE BOLT	1
36-015-075	1/4"-20 STAINLESS STEEL WING NUT	1
36-015-077	RETAINER LATCH PIVOT PIN	1
36-015-080	3/16" DIAMETER X 1" LONG STAINLESS STEEL DOWEL PIN	2
36-015-081	EXTENSION TUBE HOLDER	1
36-015-084	SPLASH SHIELD RETAINING RING	1
36-015-087	1-1/2" X 12" STAINLESS STEEL EXTENSION TUBE ASSEMBLY	1
36-015-159	ECCENTRIC CHICKEN WING FLEX LANCE RETAINING RING	1
36-015-160	CHICKEN WING HEX HEAD THUMB SCREW	1
36-015-161	CHICKEN WING FLEX LANCE GUIDE BUSHING (0.625" I.D.)	1
36-015-162	CHICKEN WING FLEX LANCE GUIDE BUSHING (0.750" I.D.)	1
36-015-163	CHICKEN WING FLEX LANCE GUIDE BUSHING (0.437" I.D.)	1

EUROPEAN & SCREW TYPE SAFETY SHROUDS

Safe operation of hand-held control guns requires the use of a safety shroud to guard the operator from failure of the hose fitting at the point where it is connected to the gun. Both of these shrouds have a nitrite outer cover, which resists oil, water, and many solvents, and an inner layer of braided stainless steel. Safety shrouds are essential equipment and should be used in conjunction with a whip hose, which allows for connection to different high pressure sources without the need to make frequent connections to the gun.

The European Type Shroud, which will fit virtually any gun, is held in place by an adjustable strap. It is lightweight, has universal application, and it is a popular alternative to the standard screw type shroud.

The Screw Type Shroud is held in place by a shroud adapter. This style is customized to specific guns and is very reliable and durable.

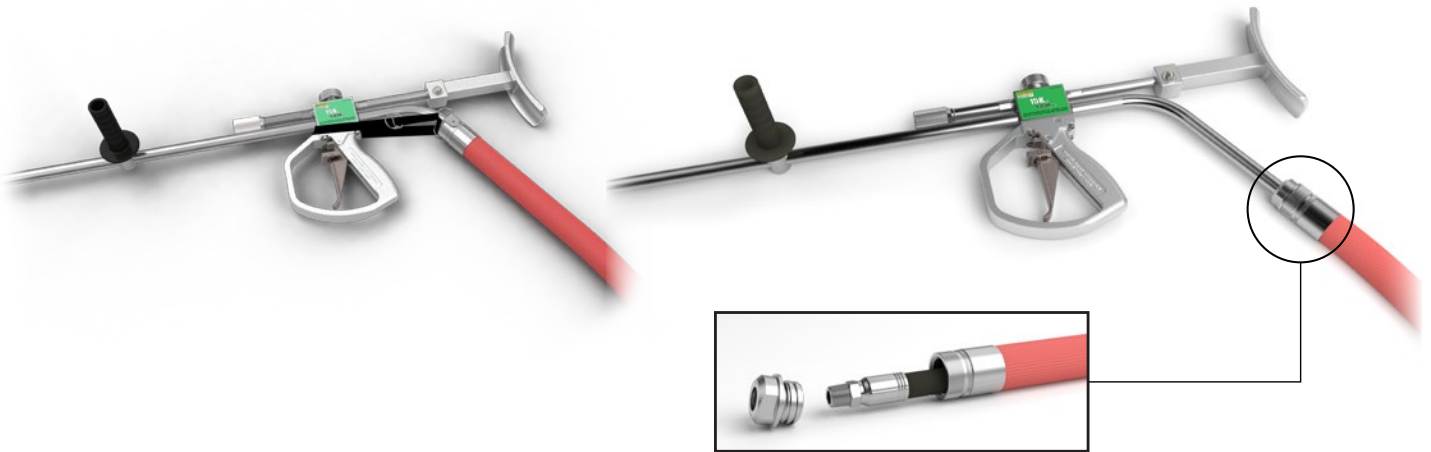

PART NO.	EUROPEAN TYPE SAFETY SHROUDS
44-021-050	15-40K EURO STYLE SAFETY SHROUD X 3' W/ MOUNTING STRAP (SHROUD ONLY)
44-021-054	15-40K EURO STYLE SAFETY SHROUD X 10' W/ MOUNTING STRAP (SHROUD ONLY)
44-021-055	15-40K EURO STYLE SAFETY SHROUD X 6' (1.83 METERS) W/ MOUNTING STRAP (40.6 MM I.D.) (SHROUD ONLY)

PART NO.	SCREW TYPE SAFETY SHROUDS
43-004-006	WHIP HOSE, 1/2" NPT B/E X 6' 15K RUBBER WATERBLAST (CERTIFIED & TESTED)
44-020-003	ASSEMBLY, 15K SAFETY SHROUD, ADAPTER & 1/2" NPT 15K WHIP HOSE X 6' (GDWJ TYPE: 77516032)
44-020-006	ASSEMBLY, 15K X 10' SAFETY SHROUD, ADAPTER & 1/2" NPT WHIP HOSE

HOSE WHIP RESTRAINTS

We strongly recommend the use of a whip check hose restrainer in any water jetting operation. These are perhaps the simplest and least expensive safety measure to implement. A whip check can be attached at any point where two hoses are joined, to a pump’s fluid end at the discharge side, or where a hose attaches to any piece of water jetting equipment, such as a water blasting lancing or cutting system.

When a high pressure hose is joined to a piece of equipment, the whip check should be used to restrain the movement of the pressurized hose, should it become uncoupled, thereby allowing operators to get away and perform a safe, orderly system shut-down.



PART NO.	HOSE WHIP RESTRAINTS
43-010-001	SAFETY WHIP CHECK, 21" GALVANIZED WIRE (1/8") & SS SPRINGS (1/2"-1/1/4" HOSE)
43-010-002	SAFETY WHIP CHECK, NYLON 1-PLY W/ RUBBER GROMMET STOPS (APPROXIMATELY 31-1/2" LONG)
43-010-003	SAFETY WHIP CHECK, 38" CS PLATED WIRE (1/4") & SPRINGS (1-1/2" - 3" HOSE)
43-010-004	SAFETY WHIP CHECK, NYLON 2-PLY W/ RUBBER GROMMET STOPS (APPROXIMATELY 64" LONG)
43-010-005	SAFETY WHIP CHECK, NYLON 2-PLY W/ RUBBER GROMMET STOPS (APPROXIMATELY 44" LONG)

TURTLESKIN® COVERALL™ COMPLETE SUIT

The WaterArmor CoverAll is a two-piece suit with full protection for hydroblasting over the entire front of the suit. It is tested with straight single nozzles, which are far more dangerous than dual nozzle rotating units. We also test with 20,000psi (1400 bar) high flow hydrodemolition nozzle to ensure your safety. The WaterArmor CoverAll product consists of three parts: the Bunker Pants, the Jacket and Neck Guard. The whole system is built around the same high performance WaterArmor protection - now within a rain-suit format, so it is really fast to gear-on and gear-off on the job.



TURTLESKIN® COVERALL™ COMPLETE JACKET

The jacket has a center opening zipper and has protection for left and right side of the torso. With the bib panel in the bunker pants, this system provides full hydroblasting protection across the critical chest area, including the vulnerable zipper area.

The WaterArmor CoverAll Jacket has 2 armor panels on each side of the zipper. In addition the Coverall has Arm and Neck protection that integrates smoothly with the Jacket garment.



PART NO.	COVERALL™ COMPLETE SUIT
55-002-001-SM	WAC0-S000, SMALL COVERALL COMPLETE SUIT (JACKET, NECK, ARMS & PANTS)
55-002-001-MED	WAC0-S000, MEDIUM COVERALL COMPLETE SUIT (JACKET, NECK, ARMS & PANTS)
55-002-001-LRG	WAC0-S000, LARGE COVERALL COMPLETE SUIT (JACKET, NECK, ARMS & PANTS)
55-002-001-XL	WAC0-S000, EXTRA LARGE COVERALL COMPLETE SUIT (JACKET, NECK, ARMS & PANTS)
55-002-001-XXL	WAC0-S000, XX LARGE COVERALL COMPLETE SUIT (JACKET, NECK, ARMS & PANTS)

PART NO.	COVERALL™ COMPLETE JACKET
55-002-002-SM	WAC0-CJ00, SMALL COVERALL COMPLETE JACKET
55-002-002-MED	WAC0-CJ00, MEDIUM COVERALL COMPLETE JACKET
55-002-002-LRG	WAC0-CJ00, LARGE COVERALL COMPLETE JACKET
55-002-002-XL	WAC0-CJ00, EXTRA LARGE COVERALL COMPLETE JACKET
55-002-002-XXL	WAC0-CJ00, XX LARGE COVERALL COMPLETE JACKET

TURTLESKIN® COVERALL™ JACKET

The jacket has a center opening zipper and has protection for left and right side of the torso. With the bib panel in the bunker pants, this system provides full hydroblasting protection across the critical chest area, including the vulnerable zipper area. The jacket has options for integrated arm protection and is setup to carry an optional neck protector. Like the pants, all of the armor panels are removable for service and cleaning of the jacket.

The WaterArmor CoverAll Jacket has 2 armor panels on each side of the zipper. In addition the Coverall has optional Arm and Neck protection that integrates smoothly with the Jacket garment.



PART NO.	COVERALL™ JACKET
55-002-003-SM	WAC0-J000, SMALL COVERALL JACKET (NO NECK OR ARMS)
55-002-003-MED	WAC0-J000, MEDIUM COVERALL JACKET (NO NECK OR ARMS)
55-002-003-LRG	WAC0-J000, LARGE COVERALL JACKET (NO NECK OR ARMS)
55-002-003-XL	WAC0-J000, EXTRA LARGE COVERALL JACKET (NO NECK OR ARMS)
55-002-003-XXL	WAC0-J000, XX LARGE COVERALL JACKET (NO NECK OR ARMS)

TURTLESKIN® COVERALL™ BUNKER PANTS

The pants are bunker style with suspenders. The pants carry protection for the legs, groin and center chest. There are knee pockets for integral knee pads. The armor panels are all removable for cleaning and service of the pants.

The CoverAll bunker pants carry the armor elements for the legs the center chest and the groin. The sequence of snaps allows the user to move the chest armor and groin armor up and down. This lets the user adjust the bunker pants for maximum protection and all day comfort.

* Does NOT include gaiters shown in picture.



PART NO.	COVERALL™ BUNKER PANTS
55-002-004-SM	WAC0-P000, SMALL COVERALL PANTS
55-002-004-MED	WAC0-P000, MEDIUM COVERALL PANTS
55-002-004-LRG	WAC0-P000, LARGE COVERALL PANTS
55-002-004-XL	WAC0-P000, EXTRA LARGE COVERALL PANTS
55-002-004-XXL	WAC0-P000, XX LARGE COVERALL PANTS

TURTLESKIN® COVERALL™ ARM INSERTS

The armor panels are carried inside the nylon shell and are easily removed for cleaning and maintenance. Suit cleaning and repair can be done by your local repair service, or you can send it back to us at the factory. This feature keeps your CoverAll suit in top working condition.



PART NO.	COVERALL™ ARM INSERTS
xx-xxx-xxx	INSERT HERE

TURTLESKIN® COVERALL™ NECK ATTACHMENT

The new CoverAll Neck protection mounts to the shoulders of the jacket and is designed to protect operators from hose or fitting failures when running the supply hose over their shoulder. Remember, no PPE system can make up for poor equipment maintenance. Keep your hoses and lance connections in good working order, and replace worn or damaged parts.



PART NO.	COVERALL™ NECK ATTACHMENT
55-002-005	WAC0-N000, COVERALL NECK ATTACHMENT (ONE SIZE ONLY)

TURTLESKIN® MFA WATERARMOR™ SUIT

WaterArmor MFA is higher protection than all our other waterblast and hydrodemolition PPE. Because it uses a stainless steel mosaic system it weighs a little more than our other products. However, you are getting serious levels of protection for this increase in mass.



PART NO.	MFA WATERARMOR™ SUIT
55-001-003	TWA-40K, FULL BODY WATERJET SUIT, SINGLE TORSO PANEL & CHAPS, TURTLESKIN
55-001-015	FULL BODY WATERSUIT ASSEMBLY (INCLUDES 1 PC SINGLE TORSO PANEL & CHAPS / 1 PC GAUNTLET - PAIR / 1 PC GAITERS - PAIR)

TURTLESKIN® MFA WATERARMOR™ TORSO ONLY

WaterArmor MFA is higher protection than all our other waterblast and hydrodemolition PPE. Because it uses a stainless steel mosaic system it weighs a little more than our other products. However, you are getting serious levels of protection for this increase in mass.



PART NO.	MFA WATERARMOR™ TORSO ONLY
55-001-004	TWA-TORSO, TORSO ONLY, TURTLESKIN

TURTLESKIN® MFA WATERARMOR™ CHAPS

TurtleSkin MFA WaterArmor is engineered from a new lightweight composite with a higher level of resistance from exposure to UHP water jet swipes.

Waterjetting contractors rely on TurtleSkin WaterArmor to ensure a safe work environment, protect operators from accidental swipes at extreme high pressure, and reduce insurance rates.

With more than 75 documented saves, TurtleSkin WaterArmor is proven safe for the prevention of injury.



PART NO.	MFA WATERARMOR™ CHAPS
55-001-005	TWA-CHAPS, TURTLESKIN

TURTLESKIN® MFA WATERARMOR™ GAITERS

The gaiter is a flexible multi-component assembly made to conform to your boots and fit snugly and tightly to your favorite rubber boots. The MFA gaiter panels are built so that they provide full flexibility for walking, climbing, and kneeling. What makes the WaterArmor Gator design special is the triangular stainless steel mosaic. MFA stands up to longer hits with higher pressures and higher flows.

The classic WaterArmor Gaiter design has stood the test of time and has proven to be easy to use, easy to mount and it standing up to years of water blasting service.



PART NO.	MFA WATERARMOR™ GAITERS
55-001-002	TGT-40K, GAITERS - PAIRS, TURTLESKIN
55-001-010	TOE-TGT, GAITER TURTLESKIN
55-001-011	GAITER REPLACEMENT KIT, TURTLESKIN (INCLUDES STRAPS, BUCKLES & HARDWARE)

TURTLESKIN® MFA WATERARMOR™ GAUNTLETS

The WaterArmor MFA Max system also includes arm and hand protection. This gauntlet and glove combination keeps hands and arms safe while providing exceptional grip to enable users to use equipment safely.



PART NO.	MFA WATERARMOR™ GAUNTLETS
55-001-001	TWA-ARM-40K, WATERJET ARM PROTECTION, GAUNTLET - PAIRS, TURTLESKIN
55-001-012	GAUNTLET, LEFT GLOVE INSERT
55-001-013	GAUNTLET, RIGHT GLOVE INSERT
55-001-014	GAUNTLET, GLOVE (SET)

TST-SWEDEN® OVERALLS W/ HAND PROTECTION

Protection against water jets on the whole front of the legs and up to the waist, on the forearms and the integrated Hand Protections. The neoprene collar seals well around the neck while maintaining freedom of movement.



TST-SWEDEN® HAND PROTECTORS

The Hand Protection protects the hand and the forearm. The entire area around the arm is protected. Easy to put on and a thumb strap keeps it in place. Specific right and left hand designs.



PART NO.	HAND PROTECTORS
97-5100047-L	TST 10/28 HAND PROTECTOR (LEFT)
97-5100047-R	TST 10/28 HAND PROTECTOR (RIGHT)
97-5100068-L	TST 20/30 HAND PROTECTOR (LEFT)
97-5100068-R	TST 20/30 HAND PROTECTOR (RIGHT)

PART NO.	OVERALLS W/ HAND PROTECTION
97-5144047-S	TST 10/28 OVERALL W/ HAND PROTECTION (S)
97-5144047-2XL	TST 10/28 OVERALL W/ HAND PROTECTION (2XL)
97-5144047-3XL	TST 10/28 OVERALL W/ HAND PROTECTION (3XL)
97-5144047-L	TST 10/28 OVERALL W/ HAND PROTECTION (L)
97-5144047-M	TST 10/28 OVERALL W/ HAND PROTECTION (M)
97-5144047-XL	TST 10/28 OVERALL W/ HAND PROTECTION (XL)
97-5144068-2XL	TST 20/30 OVERALL W/ HAND PROTECTION (2XL)
97-5144068-3XL	TST 20/30 OVERALL W/ HAND PROTECTION (3XL)
97-5144068-L	TST 20/30 OVERALL W/ HAND PROTECTION (L)
97-5144068-M	TST 20/30 OVERALL W/ HAND PROTECTION (M)
97-5144068-S	TST 20/30 OVERALL W/ HAND PROTECTION (S)
97-5144068-XL	TST 20/30 OVERALL W/ HAND PROTECTION (XL)

TST-SWEDEN® JACKETS W/ HAND PROTECTION

The Jacket provides effective full front protection as well as around the neck and shoulders. It also has integrated Hand Protections. Ideally combined with Head Protection 20/30, Trousers and Gaiters or Boots 3000 for maximum protection.



PART NO.	JACKETS W/ HAND PROTECTION
97-5122047-L/XL	TST 10/28 JACKET W/ HAND PROTECTION
97-5122068-L/XL	TST 20/30 JACKET W/ HAND PROTECTION

TST-SWEDEN® WAISTCOATS

The Waistcoat offers effective protection and optimal comfort. Often used in combination with Head Protection 20/30, Hand Protections, Trousers, Overall and Gaiters or Boots 3000.



PART NO.	WAISTCOATS
97-5120047-3XL	TST 10/28 WAISTCOAT-3XL
97-5120047-M/2XL	TST 10/28 WAISTCOAT-M/2XL
97-5120068-3XL	TST 20/30 WAISTCOAT-3XL
97-5120068-M/2XL	TST 20/30 WAISTCOAT-M/2XL

TST-SWEDEN® WAISTCOATS W/ APRON

A thoughtful combination between Waistcoat and Apron, giving superior freedom of movement and comfort, but still offering effective protection for the whole front of the body. The construction with a Waistcoat on top helps spreading the weight of the protective garment. Hand Protections and Gaiters or Boots 3000 are suitable complements for extended protection.

The height of the Apron can be adjusted, and the size of the Waistcoat can be adjusted with hook & loops - this means that it can be used by different operators or for different purposes.



PART NO.	WAISTCOATS W/ APRON
97-5123547	TST 10/28 WAISTCOAT WITH APRON (ONE SIZE)
97-5123568	TST 20/30 WAISTCOAT WITH APRON (ONE SIZE)

TST-SWEDEN® APRONS

The full area of the Apron has built-in protection. The position of the Apron can be changed through the adjustable shoulderband. The special construction of this band helps the spreading of the weight of the Apron which is an import comfort detail.

The Apron can be upfolded and fastened for easier work in stairs and on ladders. The Apron is very easy to put on and off. Recommended for work on flat surfaces and is often used in combination with the Hand Protections and Gaiters or Boots 3000.



PART NO.	APRONS
97-5123047	TST 10/28 APRON (ONE SIZE)
97-5123068	TST 20/30 APRON (ONE SIZE)

TST-SWEDEN® TROUSERS

The Trousers are fitted with a full front protection up to the waist. The zips on the outside of the legs are protected by a sealing flap and a hook & loops flap. Wide adjustable braces in stretch material. Elastic part in the rear waist and a belt which helps to distribute weight and improves the comfort. Trousers are very popular among workers who move a lot, climb and crawl.

For work in warm environments, Trousers can be ordered with ventilation, which distributes fresh air in the legs and up the front. Needs to hook up to an air compressor.



PART NO.	TROUSERS
97-5132047-L-XL	TST 10/28 TROUSERS
97-5132068-L-XL	TST 20/30 TROUSERS

TST-SWEDEN® DELTA COMPLETE KITS

Delta Complete Kits come with the following:

- Waistcoat
- Trousers
- Hand Protection



PART NO.	DELTA COMPLETE KITS
97-51K10047-L-XL	TST 10/28 L/XL DELTA COMPLETE KIT: WAISTCOAT, TROUSERS & HAND PROTECTION
97-51K10068-3XL	TST 20/30 2XL/3XL DELTA COMPLETE KIT: WAISTCOAT, TROUSERS & HAND PROTECTION
97-51K10068-L-XL	TST 20/30 L/XL DELTA COMPLETE KIT: WAISTCOAT, TROUSERS & HAND PROTECTION

TST-SWEDEN® SIGMA COMPLETE KITS

Sigma Complete Kits come with the following:

- Waistcoat
- Overall w/ Integrated Hand Protection



PART NO.	SIGMA COMPLETE KITS
97-51K20047-2XL	TST 10/28 2XL SIGMA COMPLETE KIT: WAISTCOAT & OVERALL W/ INTEGRATED HAND PROTECTION
97-51K20047-3XL	TST 10/28 3XL SIGMA COMPLETE KIT: WAISTCOAT & OVERALL W/ INTEGRATED HAND PROTECTION
97-51K20047-L	TST 10/28 L SIGMA COMPLETE KIT: WAISTCOAT & OVERALL W/ INTEGRATED HAND PROTECTION
97-51K20047-M	TST 10/28 M SIGMA COMPLETE KIT: WAISTCOAT & OVERALL W/ INTEGRATED HAND PROTECTION
97-51K20047-S	TST 10/28 S SIGMA COMPLETE KIT: WAISTCOAT & OVERALL W/ INTEGRATED HAND PROTECTION
97-51K20047-XL	TST 10/28 XL SIGMA COMPLETE KIT: WAISTCOAT & OVERALL W/ INTEGRATED HAND PROTECTION
97-51K20068-3XL	TST 20/30 3XL SIGMA COMPLETE KIT: WAISTCOAT & OVERALL W/ INTEGRATED HAND PROTECTION
97-51K20068-XL	TST 20/30 XL SIGMA COMPLETE KIT: WAISTCOAT & OVERALL W/ INTEGRATED HAND PROTECTION

TST-SWEDEN® GAMMA COMPLETE KITS

Gamma Complete Kits come with the following:

- Trousers
- Jacket w/ Integrated Hand Protection



PART NO.	GAMMA COMPLETE KITS
97-51K30047-L/XL	TST 10/28 L/XL GAMMA COMPLETE KIT: TROUSERS & JACKET W/ INTEGRATED HAND PROTECTION
97-51K30068-2XL/3XL	TST 20/30 2XL/3XL GAMMA COMPLETE KIT: TROUSERS & JACKET W/ INTEGRATED HAND PROTECTION
97-51K30068-L/XL	TST 20/30 L/XL GAMMA COMPLETE KIT: TROUSERS & JACKET W/ INTEGRATED HAND PROTECTION
97-51K30068-S/M	TST 20/30 S/M GAMMA COMPLETE KIT: TROUSERS & JACKET W/ INTEGRATED HAND PROTECTION

TST-SWEDEN® GAITERS

The Gaiters are to be worn outside of the user's regular protective boots. The entire are around the leg and the foot is protected. Three clips and hook and loops in the rear, and an easily adjustable strap under the sole, ensures that the Gaiters stay in place. Very comfortable and light to wear. Only in 20/30 protection level. Sold in pairs.



PART NO.	GAITERS
97-5158068	TST 20/30 GAITERS

TST-SWEDEN® 30/30 BOOTS 3000

Boots 3000 withstands "everything" within waterjetting on account of its fixed aluminum gaiters. The gaiters are molded and jointed, which gives both excellent comfort and mobility. Not suitable on uneven ground and is sensitive to small stones. (For that we recommend the Gaiter.)

The Boots conform to the requirement set out in BGR 191.



PART NO.	30/30 BOOTS 3000
97-5052080-10	TST 30/30 BOOT 3000 (SIZE 10)
97-5052080-11	TST 30/30 BOOT 3000 (SIZE 11)
97-5052080-12	TST 30/30 BOOT 3000 (SIZE 12)

TST-SWEDEN® BALACLAVA

The Balaclava, which is made of neoprene, is designed to keep the body dry. The breast lap is made of Cordura fitted with adjustable straps to hold it in place.

The Balaclava offers no protection against water jets.



PART NO.	BALACLAVA
97-5010000	TST BALACLAVA (ONE SIZE)

TST-SWEDEN® HEAD PROTECTION HELMET W/ VISOR & HEARING PROTECTORS

All Helmet with Visor and Hearing Protectors parts are tested and certified for protection against liquids with pressure up to 3000 bar / 43,500 psi. Helmet also meets the requirements for Industrial safety helmets.

The interior is comfortable and can be adjusted to a very good fit. The Visor meets the requirements for Eye protection, and it is replaceable and can be set in either the folded or up position.

Hearing Protectors are classified. They can be adjusted vertically and set in different positions against the head for optimal protection and fit. A three-point chin strap is provided in the Head Protection Kit.



PART NO.	HEAD PROTECTION HELMET
97-51K0216890	TST 20/30, 3000 BAR / 43,500 PSI HEAD PROTECTION HELMET WITH VISOR AND HEARING PROTECTORS

TST-SWEDEN® HOSE PROTECTION

To further improve the safety of the operator, it is recommended to use a Hose Protection / Shroud. The Hose Protection is placed on the hose at the connection to the lance, closest to the lance, where the hose is likely to break. There is 250mm / 9.8" solid steel collar.

This provides effective protection for the operator as it has been tested for 3000 bar / 43,500 psi. An adjustable strap holds the Hose Protection / Shroud to the lance. The Hose Protection / Shroud is smooth and flexible.



PART NO.	HOSE PROTECTION
97-5060040-0750	HOSE PROTECTION, MODEL 5920 TST (750MM LONG X 36MM ID)
97-5060060-0750	HOSE PROTECTION, MODEL 5920 TST (750MM LONG X 59MM ID)
97-5060040-1400	HOSE PROTECTION, MODEL 5940 TST (1400MM LONG X 36MM ID)
97-5060060-1400	HOSE PROTECTION, MODEL 5940 TST (1400MM LONG X 59MM ID)
97-5060050-1400	HOSE PROTECTION, MODEL 5942 TST (1400MM LONG X 47MM ID)
97-5060040-1800	HOSE PROTECTION, MODEL 5960 TST (1800MM LONG X 36MM ID)
97-5060060-1800	HOSE PROTECTION, MODEL 5960 TST (1800MM LONG X 59MM ID)

TST-SWEDEN® GREASE REMOVER, 0.50-LITER

Grease Remover, specially formulated for TST clothing. Mixed with water and applied to the soiled garment with a brush.



PART NO.	GREASE REMOVER, 0.50-LITER
97-5092000	TST GREASE REMOVER, .50 LITER

FOOT & SHIN GUARDS

Aluminum guards used to protect your feet and shins while waterblasting.

One size fits all.

STEEL TOE PVC BOOTS

Steel toe protective rubber boots. Puncture resistant and waterproof.

Sizes 6-14.

PART NO.	FOOT & SHIN GUARDS
97-001-010	ALUMINUM FOOT & SHIN GUARD (PAIR) (METATARSAL)

PART NO.	STEEL TOE PVC BOOTS	SIZE
97-001-011	16" STEEL TOE PVC BOOT	6
97-001-012	16" STEEL TOE PVC BOOT	7
97-001-013	16" STEEL TOE PVC BOOT	8
97-001-014	16" STEEL TOE PVC BOOT	9
97-001-015	16" STEEL TOE PVC BOOT	10
97-001-016	16" STEEL TOE PVC BOOT	11
97-001-017	16" STEEL TOE PVC BOOT	12
97-001-018	16" STEEL TOE PVC BOOT	13
97-001-019	16" STEEL TOE PVC BOOT	14

METATARSAL BOOTS

Features:

- Specialized compound prevents ozone deterioration for longer life of your footwear
- SAFE-STEP puncture resistant steel midsoles for maximum puncture protection
- Heavy Trac Tread™ sole and heel and knurled protective overlays are tough and durable providing longer life to your footwear to help reduce purchasing spend
- Ultra composite shank is longer, wider and positioned for optimal support to help prevent foot pain when standing all day
- SAFE-TOE steel toe protects worker from crush and impact hazards
- Removable Foot Form contour cushion insoles provide support and wick away moisture to keep workers feet dry



PART NO.	METATARSAL BOOTS	SIZE
97-001-001	METATARSAL BOOT (LACROSSE)	6
97-001-002	METATARSAL BOOT (LACROSSE)	7
97-001-003	METATARSAL BOOT (LACROSSE)	8
97-001-004	METATARSAL BOOT (LACROSSE)	9
97-001-005	METATARSAL BOOT (LACROSSE)	10
97-001-006	METATARSAL BOOT (LACROSSE)	11
97-001-007	METATARSAL BOOT (LACROSSE)	12
97-001-008	METATARSAL BOOT (LACROSSE)	13
97-001-009	METATARSAL BOOT (LACROSSE)	14
97-001-015	METATARSAL BOOT	15
97-001-016	METATARSAL BOOT	16

RAIN SUITS

We sell rain suits.

PART NO.	RAIN SUITS	SIZE
97-001-121	YELLOW RAIN SUIT	SMALL
97-001-122	YELLOW RAIN SUIT	MEDIUM
97-001-123	YELLOW RAIN SUIT	LARGE
97-001-124	YELLOW RAIN SUIT	X-LARGE
97-001-125	YELLOW RAIN SUIT	XX-LARGE

FACE SHIELDS

Lightweight economical visor provides superior protection, without the big price tag.

- Easy-to-attach impact-resistant visor provides full face protection
- Complies with ANSI Z87.1 standards when used with headgear item# 20124, or hard hat visor carrier item# 24245, both sold separately
- 0.040 clear polycarbonate construction
- 8" x 15"
- Please Note: Visors must be worn with the appropriate visor headgear or hard hat visor carrier, and ANSI approved eyewear for complete OSHA compliance



PART NO.	FACE SHIELDS
97-001-131	BRACKET, FACE SHIELD, MODEL H
97-001-132	FACE SHIELD, UNIVERSAL

SAFETY GLASSES

- Lightweight frameless protection
- Scratch resistant polycarbonate lens provides 99% UVA/B/C protection
- Anti-fog coated lens reduces fogging



PART NO.	SAFETY GLASSES
97-001-161	HARMONY 3550-C-C SAFETY GLASSES, GRAY
97-001-162	CLEAR CHEMICAL SPLASH GOGGLES

HARD HATS

Provide workers with head protection that's easy to adjust and comfortable to wear.

- Lightweight high-density polyethylene shell ensures extra durability
- Fas-Trac® III 4-point ratchet suspension offers absorbent sweatband that fully covers the headband and wearer's forehead, provides 3 levels of nape strap adjustment, lower nape strap cradles the head, and smooth ratchet rotation for easy adjustability
- Compatible with welding helmets, faceshields, and ear muffs
- Fits hat sizes 6.5 to 8
- Complies with ANSI Z89.1, Type I, Class E and G standards
- Easy to adjust
- SEI certified



PART NO.	HARD HATS
97-001-171	HARD HAT, FULL BRIM W/ RATCHET MSA - WHITE
97-001-172	HARD HAT, FULL BRIM W/ RATCHET MSA - BLUE

EAR PLUGS

- Soft, slow recovery foam seals ear canal for effective hearing protection
- Bell shape offers easy fitting and removal
- NRR 33 dB provides excellent protection
- Convenient dispenser box assures easy access
- 1 pair per polybag, 100 pair per dispenser box



PART NO.	EAR PLUGS
97-001-181	EAR PLUG W/ CORD, MAX 30

PVC GLOVES

These gloves come in handy for a multitude of projects and daily chores. Whether you're doing yard work, cleaning up around the house or working on the car you'll always find a time where these gloves make your everyday duties a lot easier. Protect your hands from dirt and harsh chemicals that can damage your skin and hands.

CAUTION & SAFETY TAPE

Made of high strength 2 mm polyethylene, caution tape provides the durability and premium thickness you need to be visible and safe - and with 1,000 feet there is plenty to use.

PART NO.	PVC GLOVES
97-001-151	12" PVC GLOVE

PART NO.	CAUTION & SAFETY TAPE
97-001-141	RED & BLACK DANGER TAPE
97-001-142	YELLOW & BLACK CAUTION TAPE - 3 INCHES X 1000 FT

Banshee tube cleaning nozzles use high pressure water as a liquid bearing, thereby eliminating ball bearings, seals or lubricant used in conventional rotary tools. Each tool is easily configured to suit any application by choosing from a variety of replaceable heads and inlet options.



Tool Model	Tube I.D. Range	Max Pressure	Max Pressure (BSPP Inlet)	Flow Range	Inlet Connections	Diameter	Length
BN9.5	0.47 - 0.63 in. 12 - 16 mm	22K psi 1500 bar	N/A	4.50 - 8 GPM 17 - 30 l/min	M7, 1/16" NPT, 1/4" LH or 1/4" RH	0.37 in. 9.50 mm	2.60 in. 65 mm
BN13	0.60 - 1.00 in. 15 - 25 mm	22K psi 1500 bar	18K psi 1250 bar	7 - 10 GPM 27 - 38 l/min	1/8" NPT, 1/8" BSPP, 1/4" LH, 1/4" RH, 3/8" LH or 3/8" RH	0.50 in. 13 mm	2.90 in. 74 mm
BN15	0.75 - 1.20 in. 19 - 30 mm	22K psi 1500 bar	18K psi 1250 bar	8 - 10 GPM 30 - 38 l/min	1/8" NPT, 1/8" BSPP, 3/8" LH or 3/8" RH	0.60 in. 15mm	3.00 in. 76 mm
BN18	0.87 - 1.30 in. 22 - 33 mm	22K psi 1500 bar	20K psi 1400 bar	8 - 14 GPM 30 - 53 l/min	1/4" NPT, 1/4" BSPP, 9/16" LH or 9/16" RH	0.69 in. 18 mm	3.80 in. 97 mm
BN24	1.10 - 2.00 in. 28 - 51 mm	22K psi 1500 bar	22K psi 1500 bar	12 - 25 GPM 45 - 95 l/min	3/8" NPT, 3/8" BSPP, 9/16" LH or 9/16" RH	0.93 in. 24 mm	5.10 in. 130 mm
BN33	1.50 - 2.4 in. 38 - 60 mm	22K psi 1500 bar	15K psi 1000 bar	12 - 49 GPM 45 - 190 l/min	1/2" NPT, 1/2" BSPP or 9/16" MP	1.3 in. 33 mm	6.90 in. 180 mm
BT12	0.60 - 1.00 in. 15 - 25 mm	22K psi 1500 bar	N/A	Up to 8.50 GPM 32 l/min	P1, M7, MPL4, MPR4	0.50 in. 13 mm	1.30 in. 33 mm
BT18	0.87 - 1.30 in. 22 - 33 mm	22K psi 1500 bar	18K psi 1250 bar	Up to 11 GPM 42 l/min	P1, P2, BSPP2, MPL6, MPR6, MPL4, MPR4	0.69 in. 18 mm	1.50 in. 39 mm
BT25	1.20 - 3.00 in. 30 - 76 mm	8 - 22K psi 550 - 1500 bar	N/A	8 - 20 GPM 30 - 76 l/min	1/8" NPT, 1/4" NPT, 1/4" BSPP, 3/8"-28 LH or 3/8"-28 RH, 9/16"-18 LH or 9/16"-18 RH	1.00 in. 26 mm	1.90 in. 48 mm

BARRACUDA®

Rotary Shotgun Tools

Barracuda self-rotary tools are the industry standard for rotary shotgunning. Excellent for irregular surfaces where an operator using a hand-held tool can more efficiently maneuver. Also used on automated and hands-free equipment.

Features:

- Effective shotgunning for a wide range of pressure
- Jet reaction creates rotation - no need for compressed air
- Light weight eases operator fatigue
- Field maintainable and easily rebuilt at a low cost
- Four port heads for tin, harder deposits can be configured to two port applications for thicker, softer deposits



Tool Model	Pressure Range	Flow Range	Inlet Connections	Weight	Max Water Temperature
BC-K	2 - 22K psi 140 - 1500 bar	4.40 - 11 GPM 17 - 42 l/min	9/16" MP	2.70 lb 1.20 kg	160° F 70° C
BC-K-P2	5 - 22K psi 340 - 1500 bar	4 - 13 GPM 16 - 49 l/min	9/16" MP	2.70 lb 1.20 kg	160° F 70° C
BC-H9-C	20 - 40K psi 1400 - 2800 bar	5 - 7.40 GPM 19 - 28 l/min	9/16" HP	2.90 lb 1.30 kg	160° F 70° C
BC-H9LF-C	20 - 40K psi 1400 - 2800 bar	2.90 - 4.80 GPM 11 - 18 l/min	9/16" HP	2.90 lb 1.30 kg	160° F 70° C
BC-H9XXLF-C-TI	20 - 40K psi 1400 - 2800 bar	1.70 - 3.10 GPM 6 - 12 l/min	9/16" HP	3.20 lb 1.45 kg	160° F 70° C

2" BADGER®*Self-Rotary Swivel*

The 2" Badger is a self-rotating swivel designed for cleaning 2–4 in. (51–102 mm) pipes with bends and long radius elbows, such as U-Tubes and process lines. The latest design includes a spring-loaded pin that ratchets the head to machined edges on the shaft. Therefore, the head can only be removed with a special head removal tool and not while in operation.

Features:

- The only self-rotary tool on the market that can navigate 2 in. (50 mm) pipes with bends
 - The only tool in the industry with head locking technology for increased safety
 - Unique compact design allows the tool to easily navigate pipe bends
- Multiple jetting options allow the tool to be optimized for a variety of pump pressure and flows - unplug, polish, or run longer lines based on jetting
 - Optional fairing available to streamline tool during retrieval
 - Pair with the ABX-PRO for hands-free mole lining



Tool Model	Pressure Range	Flow Range	Inlet Connections	Weight	Max Water Temperature
BA-LK-P4 BA-LK-BSPP4	2 - 15K psi 140 - 1000 bar	3 - 20 GPM 11 - 76 l/min	1/4" NPT or 1/4" BSPP	0.45 lb 0.20 kg	250° F 120° C
BA-LK-MP9L BA-LK-MP9R	12 - 22K psi 830 - 1500 bar	3 - 15 GPM 11 - 57 l/min	9/16" MP or M24	0.45 lb 0.20 kg	250° F 120° C

4" BADGER®

Self-Rotary Swivel

The 4" Badger self-rotary tool makes cleaning pipes with elbows easy, navigating 4 in. (102 mm) bends with controlled rotation which is important for efficiently cleaning larger pipes. The operator can choose between two rotation speeds by selecting fast or slow viscous fluid.

Features:

- Different jetting configurations allow for increased or decreased pull and forward hitting power
- Designed to pair with the AutoBox ABX-500 hose handling system for hands-free pipe cleaning
- Navigates elbows as small as 4 in. (102 mm)
- Self-rotary, speed control provides complete internal coverage, while speed control provides optimum jet delivery
- Two speeds to choose from to maximize cleaning: slower speeds for hard to clean or plugged pipes, and faster speeds for polishing easy to clean pipes with a single tool
- Multiple jetting options optimize the tool for a variety of pumps pressures and flows - unplug, polish, or run longer lines based on jetting



Tool Model	Pressure Range	Flow Range	Inlet Connections	Rotation Speed	Weight
BA-P6 BA-BSPP6	2 - 15K psi 140 - 1000 bar	13 - 30 GPM 49 - 110 l/min	3/8" NPT or 3/8" BSPP	20 - 100 RPM (Slow Fluid) 75 - 250 RPM (Fast Fluid)	3.00 lb 1.40 kg
BA-TM12	12 - 22K psi 830 - 1500 bar	12 - 25 GPM 45 - 95 l/min	3/4" Type M Male	20 - 100 RPM (Slow Fluid) 75 - 250 RPM (Fast Fluid)	3.00 lb 1.40 kg
BA-H6	43.5K psi 3000 bar	4.5 - 12 GPM 17 - 45.5 l/min	3/8" HP Female	100 - 400 RPM	4.00 lb 1.80 kg

6" BADGER®*Self-Rotary Swivel*

The 6" Badger features adjustable speed control which allows operators to meet the demands of the task at hand – slower speeds for tough deposits and plugs, faster rotation for easier jobs or polishing.

Features:

- Only rotary pipe cleaning tool on the market with adjustable speed control for fine-tuning to specific requirements
 - Different jetting configurations allow for more or less pull and forward hitting power
 - Navigates elbows as small as 6 in. (152 mm)
- Speed controlled rotary tools provide complete internal coverage, while providing optimum jet delivery
- Maximize cleaning by choosing slower speeds for hard to clean or plugged pipes and faster speeds for polishing easy to clean pipes with a single tool
 - Optimize the tool for a variety of pumps pressure and flows with multiple jetting options
 - Pair with the ABX-500 for hands-free pipe cleaning



Tool Model	Pressure Range	Flow Range	Rotation Speed	Inlet Connections	Weight	Max Operating Temperature
BA-P8	2 - 15K psi 140 - 1000 bar	15 - 55 GPM 57 - 208 l/min	50 - 300 RPM (Adjustable)	1/2" NPT	8.00 lbs 3.60 kg	250° F 120° C
BA-MP9 BA-M24	12 - 22K psi 840 - 1500 bar	14 - 43 GPM 53 - 163 l/min	50 - 300 RPM (Adjustable)	9/16" MP or M24	8.00 lbs 3.60 kg	250° F 120° C

GOPHER™

Self-Rotary Swivel

The Gopher self-rotary tool is ideal for cleaning evaporator tubes and a variety of process lines. It is ideal for cutting through coke, polymers, coatings and latex. The Gopher is offered in two pressure ranges up to 40K psi (2800 bar).

The Gopher can be paired with StoneAge® automated tube cleaning systems to facilitate hands-free lancing of large diameter tubes such as those found in industrial evaporators and condensers.

Features:

- Self-rotary, speed control provides complete internal coverage, while speed control provides optimum jet delivery
- Two head options available: 7-port unplugging option for maximum forward hitting power, and a 6-port polishing head for IRIS inspection polishing
- Multiple jetting configurations means the same tool can be re-jetted to match a wide variety of cleaning applications - great for when you need more pulling force or forward hitting power



Tool Model	Pressure Range	Flow Range	Rotation Speed	Inlet Connections	Weight	Max Operating Temperature
GO-MP9	2 - 22K psi 140 - 1500 bar	18 - 25 GPM 30 - 95 l/min	600 - 1000 RPM	9/16" MP	3.00 lbs 1.36 kg	160° F 70° C
GO-H9-C	22 - 40K psi 1500 - 2800 bar	4 - 10 GPM 15 - 40 l/min	600 - 1000 RPM	9/16" HP	3.30 lbs 1.50 kg	160° F 70° C

BJV™ SERIES*Self-Rotary Swivel*

The BJV family is our most versatile line of pipe cleaning tools, designed for the widest range of configurations. A variety of head choices allow for pulling ring connections, customized porting, and multiple jetting options. Different viscous fluid options give operators the ability to change the rotation speed for hard or easy applications. BJV tools can be used with a wide range of centralizers and back-out preventers for added safety, and they are also highly effective tank and stack cleaners.

Features:

- Clean 6 in. (152 mm) pipes to 15 ft (4.5 m) diameter tanks with simple modifications
 - Interchangeable heads allow the tool to be used on any type of pump
- Multiple head options to allow for flush mounted nozzles, extension arms, plugs, and pulling rings
 - Simple nozzle changes allow operators to configure for many cleaning applications
 - Easy to pair with AutoBox ABX-500 for hands-free pipe cleaning



Tool Model	Pressure Range	Flow Range	Rotation Speed	Inlet Connections	Weight	Max Water Temperature
BJV-P16	2 - 10K psi 140 - 700 bar	20 - 200 GPM 76 - 757 l/min	20 - 80 RPM (Slow Fluid) 50 - 200 RPM (Fast Fluid)	1" NPT	9.20 lbs 4.20 kg	160° F 70° C
BJV-P12	2 - 15K psi 140 - 1000 bar	12 - 100 GPM 45 - 380 l/min	20 - 80 RPM (Slow Fluid) 40 - 200 RPM (Fast Fluid)	3/4" NPT	8.60 lbs 3.90 kg	160° F 70° C
BJV-M24	2 - 22K psi 140 - 1500 bar	12 - 100 GPM 45 - 380 l/min	20 - 80 RPM (Slow Fluid) 40 - 200 RPM (Fast Fluid)	M24	9.00 lbs 4.10 kg	160° F 70° C
BJV-MP12	2 - 22K psi 140 - 1500 bar	10 - 60 GPM 38 - 230 l/min	20 - 50 RPM (Slow Fluid) 70 - 300 RPM (Fast Fluid)	3/4" MP	9.40 lbs 4.30 kg	160° F 70° C
BJV-H9	20 - 40K psi 1400 - 2800 bar	3.40 - 20 GPM 13 - 76 l/min	20 - 60 RPM (Slow Fluid) 90 - 250 RPM (Fast Fluid)	9/16" HP	9.30 lbs 4.40 kg	160° F 70° C

RAPTOR™

Self-Rotary Swivel

The Raptor 2-D self-rotating tool is used to clean process drains, totes, closed head drums, water well screens, ducts, and exhaust stacks. Combined with a centralizer, it cleans pipes from 3–12 in. (76–305 mm) in diameter and can clean straight tubes as small as 2.25 in. (57 mm) in diameter.

The Raptor uses viscous fluid speed control and operates with 2, 4, or 6 jets in balance. We recommend using a centralizer to protect the head and improve jet action on the wall being cleaned.

Features:

- High flow range aids in removing thick, tough deposits
- Controlled rotation for longer jet dwell times for difficult deposits
- Multiple jetting options allows for fine tuning heads to optimize cleaning
- Optional pull ring connection aids in jobs where tool needs to be pulled through the pipe
- Multiple head options available
- Optional entering devices available



Tool Model	Pressure Range	Flow Range	Rotation Speed	Inlet Connections	Length	Weight
RPT	Up to 22K psi 1500 bar	Up to 60 GPM 230 l/min	15 - 60 RPM (Slow Fluid) 50 - 250 RPM (Fast Fluid)	1/2" NPT, 9/16" MP or M24	9.5 in. 240 mm	5.50 lb 2.50 kg

SPITFIRE®*Shotgun Swivel*

The Spitfire rotary shotgun tool is designed for cleaning difficult and irregular surfaces where manual shotgun cleaning is required. The extra lightweight Spitfire requires little maintenance, reducing down time and increasing productivity.

Features:

- Handles a wide range of pressure rating from 2 - 22K psi (140 - 1500 bar)
- Fewer tools to buy to cover all applications and less downtime changing or rebuilding tools
 - High speed rotation is excellent for removing thin coatings
- Angled jets allow for broader impact for quicker, more effective cleaning of large surfaces and odd shapes
 - Fewer parts and no seals to stock or replace - reduced costs and maintenance downtime
- Short overall tool length and light weight makes for easy handling, reducing operator fatigue
 - External shield option protects the tool from damage caused by lateral impacts



Tool Model	Pressure Range	Flow Range	Rotation Speed	Inlet Connections	Weight	Max Water Temperature
SPFR-P8-S SPFR-P8-B	5 - 15K psi 340 - 1000 bar	2 - 15 GPM 8 - 58 l/min	3000 - 5000 RPM	1/2" NPT	1.50 lb / 0.70 kg (S) 1.70 lb / 0.80 kg (B)	212° F 100° C
SPFR-MP9-S SPFR-MP9-B	5 - 22K psi 340 - 1500 bar	4 - 13 GPM 16 - 49 l/min	3000 - 5000 RPM	9/16" MP	1.50 lb / 0.70 kg (S) 1.70 lb / 0.80 kg (B)	250° F 120° C

ATTACK TIPS™

Waterblast Accessories

StoneAge Attack Tips are the highest quality, longest lasting nozzles available for low and medium pressure applications up to 22K psi (1500 bar). Flow straighteners correct turbulence, ensuring excellent jetting results.

Pressure Range:

- 2 - 22K psi (140 - 1500 bar)

Flow Range:

- 0.60 - 46.00 gpm (2.27 - 174 l/min)

Orifice I.D.		Pressure Continuum												Flow Rating
<i>in.</i>	<i>mm</i>	2K psi 140 bar	4K psi 280 bar	6K psi 410 bar	8K psi 550 bar	10K psi 700 bar	12K psi 830 bar	14K psi 970 bar	15K psi 1000 bar	16K psi 1100 bar	18K psi 1200 bar	20K psi 1400 bar	22K psi 1500 bar	<i>gpm</i>
0.018	0.46	0.39	0.55	0.68	0.78	0.87	0.96	1.00	1.10	1.10	1.20	1.20	1.30	0.60
0.020	0.51	0.48	0.68	0.83	0.96	1.10	1.20	1.30	1.30	1.50	1.50	1.50	1.60	0.70
0.022	0.56	0.58	0.82	1.00	1.20	1.30	1.40	1.50	1.60	1.60	1.70	1.80	1.90	0.80
0.024	0.61	0.69	0.98	1.20	1.40	1.60	1.70	1.80	1.90	2.00	2.10	2.20	2.30	1.00
0.026	0.66	0.81	1.20	1.40	1.60	1.80	2.00	2.10	2.20	2.30	2.40	2.60	2.70	1.10
0.029	0.74	1.00	1.40	1.70	2.00	2.30	2.50	2.70	2.80	2.90	3.00	3.20	3.40	1.40
0.032	0.81	1.20	1.70	2.10	2.50	2.80	3.00	3.30	3.40	3.50	3.70	3.90	4.10	1.70
0.035	0.89	1.50	2.10	2.60	3.00	3.30	3.60	3.90	4.00	4.20	4.40	4.70	4.90	2.10
0.038	0.97	1.70	2.50	3.00	3.50	3.90	4.30	4.60	4.80	4.90	5.20	5.50	5.70	2.50
0.042	1.07	2.10	3.00	3.70	4.20	4.70	5.20	5.60	5.80	6.00	6.40	6.70	7.00	3.00
0.047	1.19	2.70	3.80	4.60	5.30	5.90	6.50	7.00	7.30	7.50	8.00	8.40	8.80	3.80
0.052	1.32	3.30	4.60	5.60	6.50	7.30	8.00	8.60	8.90	9.20	9.80	10.00	11.00	4.60
0.057	1.45	3.90	5.50	6.80	7.80	8.70	9.60	10.00	11.00	11.00	12.00	12.00	13.00	5.50
0.063	1.60	4.80	6.80	8.30	9.60	11.00	12.00	13.00	13.00	14.00	14.00	15.00	16.00	6.80
0.069	1.78	5.70	8.10	9.90	12.00	13.00	14.00	15.00	16.00	16.00	17.00	18.00	19.00	8.10
0.075	1.91	6.80	9.60	12.00	13.00	15.00	17.00	18.00	19.00	19.00	20.00	21.00	23.00	9.60
0.082	2.08	8.10	12.00	14.00	16.00	18.00	20.00	21.00	22.00	23.00	24.00	26.00	27.00	12.00
0.090	2.29	9.80	14.00	17.00	20.00	22.00	24.00	26.00	27.00	28.00	29.00	31.00	32.00	14.00
0.098	2.49	12.00	16.00	20.00	23.00	26.00	28.00	31.00	32.00	33.00	35.00	37.00	38.00	16.00
0.106	2.69	14.00	19.00	23.00	27.00	30.00	33.00	36.00	37.00	38.00	41.00	43.00	45.00	19.00
0.115	2.92	16.00	23.00	28.00	32.00	36.00	39.00	42.00	44.00	45.00	48.00	50.00	53.00	23.00
0.125	3.18	17.00	27.00	33.00	38.00	42.00	46.00	50.00	52.00	53.00	56.00	60.00	62.00	27.00
0.135	3.43	22.00	31.00	38.00	44.00	49.00	54.00	58.00	60.00	62.00	66.00	69.00	73.00	31.00
0.145	3.68	25.00	36.00	44.00	51.00	57.00	62.00	67.00	69.00	72.00	76.00	80.00	84.00	36.00
0.155	3.94	29.00	41.00	50.00	58.00	65.00	71.00	77.00	79.00	82.00	87.00	92.00	96.00	41.00
0.165	4.19	33.00	46.00	57.00	66.00	73.00	80.00	87.00	90.00	93.00	98.00	104.00	109.00	46.00

OC8 CARBIDE INSERTS*Waterblast Accessories*

We recommend using our OC8 Holders and OC8 Carbide Inserts where filtration is poor, abrasive solids are present or very high flows. Replaceable carbide inserts are available in large orifice diameters to handle high flows and contain a long taper to provide excellent jet quality.

Pressure Range:

- 2 - 22K psi (140 - 1500 bar)

Flow Range:

- 7 - 106 gpm (26.50 - 401 l/min)

Orifice I.D.		Pressure Continuum												Flow Rating
<i>in.</i>	<i>mm</i>	2K psi 140 bar	4K psi 280 bar	6K psi 410 bar	8K psi 550 bar	10K psi 700 bar	12K psi 830 bar	14K psi 970 bar	15K psi 1000 bar	16K psi 1100 bar	18K psi 1200 bar	20K psi 1400 bar	22K psi 1500 bar	<i>gpm</i>
0.063	1.60	4.80	6.70	8.20	9.50	11.00	12.00	13.00	13.00	14.00	14.00	15.00	16.00	7.00
0.075	1.91	6.80	9.60	12.00	14.00	15.00	17.00	18.00	19.00	19.00	20.00	21.00	22.00	10.00
0.085	2.16	8.70	12.00	15.00	17.00	19.00	21.00	23.00	24.00	25.00	26.00	28.00	29.00	12.00
0.095	2.41	11.00	15.00	19.00	22.00	24.00	27.00	29.00	30.00	31.00	33.00	33.00	36.00	15.00
0.105	2.67	13.00	19.00	23.00	27.00	30.00	33.00	35.00	36.00	38.00	40.00	42.00	44.00	19.00
0.125	3.18	19.00	27.00	33.00	38.00	42.00	46.00	50.00	52.00	53.00	56.00	60.00	62.00	27.00
0.145	3.68	25.00	36.00	44.00	50.00	57.00	62.00	67.00	69.00	72.00	76.00	80.00	84.00	36.00
0.165	4.19	33.00	46.00	56.00	66.00	73.00	80.00	87.00	90.00	93.00	98.00	104.00	109.00	46.00
0.175	4.45	37.00	52.00	64.00	74.00	82.00	90.00	98.00	101.00					52.00
0.190	4.83	43.00	61.00	75.00	87.00	97.00	106.00	115.00	119.00					61.00
0.200	5.08	48.00	68.00	83.00	96.00	108.00	118.00	127.00	132.00					68.00
0.215	5.46	56.00	79.00	96.00	111.00	124.00								78.00
0.235	5.97	66.00	94.00	115.00	133.00	149.00								94.00
0.250	6.35	75.00	106.00	130.00	150.00	168.00								106.00

SAPPHIRE NOZZLES

Waterblast Accessories

These nozzles are used for high pressure jetting applications where water filtration of 10 micron or better is required. Jeweled orifices make the best quality, longest lasting jets possible, especially for ultra-high pressures.

Pressure Range:

- 20 - 40K psi (1400 - 2800 bar)

Flow Range:

- 0.20 - 4.80 gpm (0.75 - 18 l/min)

Orifice I.D.		Pressure Continuum											Availability		
in.	mm	20K psi 1400 bar	22K psi 1500 bar	24K psi 1700 bar	26K psi 1800 bar	28K psi 1900 bar	30K psi 2100 bar	32K psi 2200 bar	34K psi 2300 bar	36K psi 2500 bar	38K psi 2600 bar	40K psi 2800 bar	OS4	OS6	OS7
0.009	0.23	0.20	0.20	0.20	0.30	0.30	0.30	0.30	0.30	0.30	0.30	0.30		•	
0.010	0.25	0.30	0.30	0.30	0.30	0.30	0.30	0.40	0.40	0.40	0.40	0.40	•	•	
0.011	0.28	0.30	0.40	0.40	0.40	0.40	0.40	0.40	0.40	0.50	0.50	0.50		•	•
0.012	0.30	0.40	0.40	0.40	0.40	0.50	0.50	0.50	0.50	0.50	0.60	0.60	•	•	•
0.013	0.33	0.50	0.50	0.50	0.50	0.60	0.60	0.60	0.60	0.60	0.60	0.70	•	•	•
0.014	0.36	0.50	0.60	0.60	0.60	0.60	0.70	0.70	0.70	0.70	0.70	0.80	•	•	•
0.015	0.38	0.60	0.70	0.70	0.70	0.70	0.80	0.90	0.80	0.80	0.90	0.90	•	•	•
0.016	0.41	0.70	0.70	0.80	0.80	0.80	0.90	0.90	0.90	1.00	1.00	1.00	•	•	•
0.017	0.43	0.80	0.80	0.90	0.90	0.90	1.00	1.00	1.00	1.10	1.10	1.10	•	•	•
0.018	0.46	0.90	0.90	1.00	1.00	1.10	1.10	1.10	1.20	1.20	1.20	1.30	•	•	•
0.019	0.48	1.00	1.00	1.10	1.10	1.20	1.20	1.30	1.30	1.30	1.40	1.40	•	•	•
0.020	0.51	1.10	1.20	1.20	1.30	1.30	1.40	1.40	1.40	1.50	1.50	1.60	•	•	•
0.021	0.53	1.20	1.30	1.30	1.40	1.40	1.50	1.50	1.60	1.60	1.70	1.70	•	•	•
0.022	0.56	1.30	1.40	1.50	1.50	1.60	1.60	1.70	1.70	1.80	1.80	1.90	•	•	•
0.023	0.58	1.50	1.50	1.60	1.70	1.70	1.70	1.80	1.90	1.90	2.00	2.00	•	•	•
0.024	0.61	1.60	1.70	1.70	1.80	1.90	1.90	2.00	2.10	2.10	2.20	2.20	•	•	•
0.025	0.64	1.70	1.80	1.90	2.00	2.00	2.10	2.20	2.20	2.30	2.40	2.40	•	•	•
0.026	0.66	1.90	1.90	2.00	2.10	2.20	2.30	2.30	2.40	2.50	2.60	2.60	•	•	
0.027	0.69	2.00	2.10	2.20	2.30	2.40	2.50	2.50	2.60	2.70	2.80	2.80	•	•	
0.028	0.71	2.20	2.30	2.40	2.50	2.60	2.50	2.70	2.80	2.90	3.00	3.10	•	•	•
0.029	0.74	2.30	2.40	2.50	2.60	2.80	3.00	3.20	3.40	3.50	3.60	3.70	•	•	
0.031	0.79	2.60	2.80	2.90	3.00	3.10	3.20	3.30	3.40	3.60	3.80	4.00	•	•	•
0.033	0.84	3.00	3.10	3.30	3.40	3.50	3.70	3.80	3.90	4.00	4.10	4.20			•
0.034	0.86	3.20	3.30	3.50	3.60	3.80	3.90	4.00	4.20	4.30	4.40	4.50	•	•	
0.035	0.89	3.40	3.50	3.70	3.80	4.00	4.10	4.30	4.40	4.50	4.60	4.80	•		•
0.036	0.91	3.60	3.70	3.90	4.00	4.20	4.40	4.50	4.60	4.80	4.90	5.00	•	•	•
0.037	0.94	3.70	3.90	4.10	4.30	4.40	4.60	4.80	4.90	5.00	5.20	5.30		•	•
0.039	0.99	4.20	4.40	4.60	4.70	4.90	5.10	5.30	5.40	5.60	5.70	5.90	•	•	•
0.047	1.20	6.10	6.40	6.60	6.90	7.20	7.40	7.70	7.90	8.10	8.40	8.60		•	•

EXTENSION NIPPLES*Waterblast Accessories*

Maximize jet power and removal rates by placing nozzles close to the target surface. Extension nipples also enhance jet quality by improving upstream conditions. Standard lengths in stock for all StoneAge tools.

Custom lengths available.

Type	Part No.	MAWP	Threads	O.D.	I.D.
9/16" MP Tubing	SA 567-P4P2*	22K psi (1500 bar)	1/4" NPTM x 1/8" NPTF	0.56 in. (14 mm)	0.31 in. (8 mm)
9/16" MP Tubing	SA 567-MP9P2	22K psi (1500 bar)	9/16" MP x 1/8" NPTF	0.56 in. (14 mm)	0.31 in. (8 mm)
9/16" MP Tubing	SA 567-MP9MP9	22K psi (1500 bar)	9/16" MP x 9/16" MP	0.56 in. (14 mm)	0.31 in. (8 mm)
1/2" Scheduled 160 Pipe	SA 356-P8P4**	15K psi (1000 bar)	1/2" NPTM x 1/4" NPTF	0.84 in. (21 mm)	0.47 in. (12 mm)
1/2" Scheduled 160 Pipe	SA 356-P8P8	15K psi (1000 bar)	1/2" NPTM x 1/2" NPTM	0.84 in. (21 mm)	0.47 in. (12 mm)
3/4" Scheduled 160 Pipe	SA 366-P12P12	15K psi (1000 bar)	3/4" NPTM x 3/4" NPTM	1.10 in. (27 mm)	0.61 in. (16 mm)
3/4" MP Tubing	SA 577-MP12LMP12L-19	22K psi (1500 bar)	3/4" MP x 3/4" MP	0.75 in. (19 mm)	0.44 in. (11 mm)
3/4" MP Tubing	SA 577-MP12LP4-10	22K psi (1500 bar)	3/4" MP x 1/4" NPTF	0.75 in. (19 mm)	0.44 in. (11 mm)
3/4" MP Tubing	SA 577-G12P4**	22K psi (1500 bar)	3/4" G12 x 1/4" NPTF	0.75 in. (19 mm)	0.44 in. (11 mm)
9/16" HP Tubing	SA 569-G9S6*	40K psi (2800 bar)	9/16" G9 x 3/8"-24 F	0.56 in. (14 mm)	0.19 in. (5 mm)

TUBE NOZZLE DRILL PATTERNS

Use these handy reference for jet locations when designing your custom drilled orifice patterns. Our support staff can offer their extensive knowledge and experience to help you in the selection process.

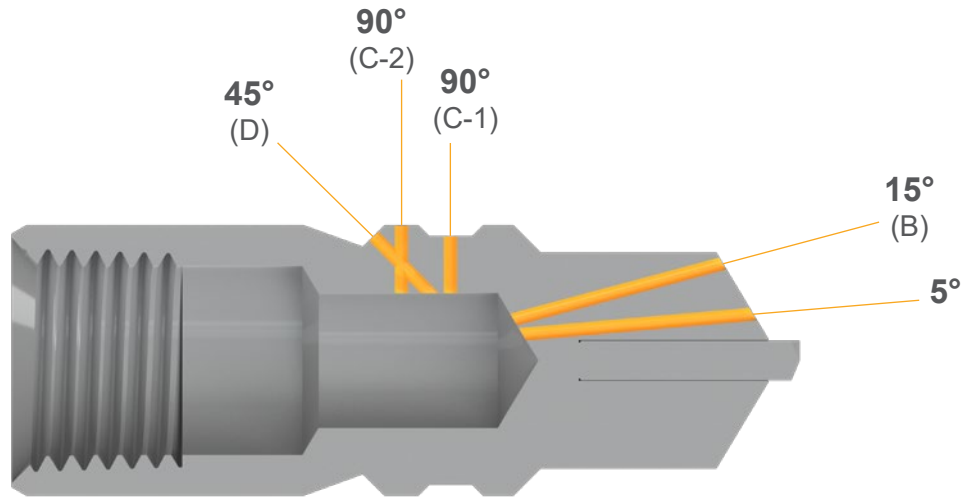

STANDARD NOZZLES W/ CARBIDE BLADE DRILL PATTERNS

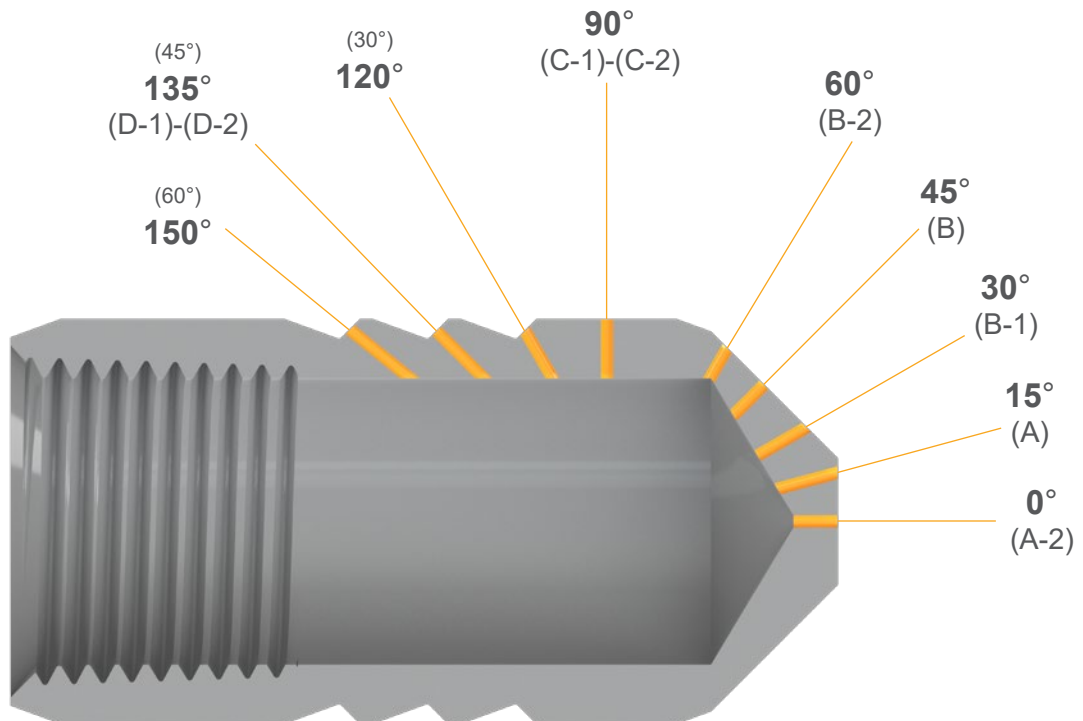

TYPICAL TUBE NOZZLE DRILL PATTERNS

Conditions of Sale & Warranty

You are responsible for your own safety. Advanced Pressure Systems (APS) publishes guides for the safe use of water blasting equipment. Please read them.

We also strongly advise that all personnel are fully conversant with the “*Recommended Practices for the Use of Manually Operated High Pressure Water Jetting Equipment*”, published by the Water Jet Technology Association. These may be obtained free of charge by contacting Advanced Pressure Systems, LLC.

General: These terms and conditions, the terms and conditions included in the quotations or order acknowledgment (if any) are applicable to all products offered for sale by APS Pressure Systems, LLC (“APS”), constitute the “Agreement” between APS and the Purchaser and may not be varied, except as agreed in writing by APS.

Terms of Sale:

1. The Purchaser agrees to hold APS harmless for any and all claims arising from the misuse or misapplication of any product manufactured or supplied by APS.
2. Products returned for credit will be subject to 15% restocking charge. Only standard Products will be accepted for restocking. All sales of non-standard items are final.
3. Payment may be made by credit cards issued by VISA or MASTERCARD. Payment by credit cards issued by AMERICAN EXPRESS will be subject to 3% service or charge.

Delivery: Unless otherwise specified by APS, delivery will be made DAP (Delivery at Place, Incoterms® 2010), at the Purchaser’s location or facility. Title and risk of loss or damage passes to Purchaser on delivery.

Warranty: The following classes of products carry the warranty indicated. Any component included in an assembled product which is subject to wear is not warranted. Products which have been subject to abuse including misapplication, corrosion, excessive pressure, over-tightening and galling screw threads will not be accepted for replacement under warranty.

Products not manufactured by APS will carry the warranty of the respective manufacturer.

1. **Hoses:** Not warranted. Coupling may be warranted by manufacturer.
2. **Rigid Lances:** Ninety (90) days from date of shipment.
3. **Plungers & Pump Packing:** Not warranted.
4. **Control Guns, Flow Divider Valves & Flow Control Valves:** Ninety (90) days from date of shipment.
5. **Relief Valves:** One-hundred eighty (180) days from date of shipment.
6. **Nozzles & Nozzle Inserts / Orifices:** Not warranted.
7. **Fittings, Connectors & Couplings:** One-hundred eighty (180) days from date of shipment.

Limitation of Warranties: EXCEPT AS PROVIDED IN THE WARRANTY SECTION ABOVE, APS MAKES NO OTHER WARRANTIES TO PURCHASER, EXPRESSED OR IMPLIED, AND HEREBY EXPRESSLY DISCLAIMS ANY WARRANTY OF MERCHANTABILITY OR FITNESS FOR A PARTICULAR PURPOSE.

Shipping Costs: Orders may be shipped prepaid by any regularly available means, and the cost will be paid by the Purchaser. Other costs, including but not limited to: insurance for the full retail value of the products, packaging, crating and any other handling costs will be billed to the Purchaser. If the Purchaser collects the products from APS' Houston plant there will not be any shipping charges.

Payment: All invoices are due net 30 days from date of shipment. Any invoices which are more than 30 days past due will result in the account of the Purchaser to be placed on hold.

Taxes: In addition to any prices specified by APS in the Agreement, Purchaser shall bear, pay and be responsible for the gross amount of any present or future taxes, duties or levies, of a sales, use, excise, value added, goods and services or other similar nature, applicable to or assessable on the price, sale or delivery of any products or services furnished under the Agreement or to their use by APS or Purchaser or otherwise applicable to the transactions under the Agreement, or Purchaser shall furnish APS with evidence of exemption acceptable to the taxing authorities.

Limitation of Damages: APS SHALL NOT BE LIABLE FOR INCIDENTAL OR CONSEQUENTIAL DAMAGES INCLUDING, BUT NOT LIMITED TO, LOSS OF PROFITS, LOSS OF USE, LOSS OF PRODUCTION, DAMAGE TO OTHER EQUIPMENT, COST OF CAPITAL OR INTEREST. APS' LIABILITY IS LIMITED TO REPAIR OR REPLACEMENT OF THE EQUIPMENT AND THE DETERMINATION, REGARDING WHICH OF THESE IS APPROPRIATE, SHALL BE AT APS' SOLE DISCRETION. THE PARTIES AGREE THAT THE FOREGOING REMEDY IS REASONABLE AND DOES NOT CAUSE THE AGREEMENT TO FAIL IN ITS ESSENTIAL PURPOSE.

Intellectual Property: No ownership of any patent, copyright, trade secret, technical data or other industrial or intellectual property is transferred to Purchaser under this Agreement. No products sale is to be construed as the grant by APS to the Purchaser of any license to copy, modify, revise or reconstruct anything falling within the scope of patents, copyrights, trade secrets, technical data, or other industrial property of APS or third parties.

Applicable Law: Any question concerning the validity, construction, or performance of this Agreement will be governed by the laws of the State of Texas, USA.

We place a high degree of emphasis on Quality Assurance for our products. Our inspection processes for in-house manufactured components follow industry best practices for machine shops. First article, in process and final inspections are carried out using cutting edge technology as well as the traditional and time-tested equipment and methods.

Inspection Equipment:

- OPTIV 3 Classic Optical Coordinate Measuring Machine (CMM)
- Keyence IM-6020 Image Dimension Measuring System (IM)
- Thermo Scientific Niton XRF Analyzer
- Mitutoyo PH-A14 Optical Comparator
- Wilson Rockwell Tester
- Faro Arm
- Mitutoyo SJ0201 Profilometer
- Sunnen Precision Bore Gauges PG-810 and PG-700
- Mitutoyo Linear Height 600
- *And a full complement of precision micrometers, calipers, surface plates, digital height indicators, standard plug, ring & thread gauges*

