

ZWR fan units

USER'S MANUAL

GRAPHIC SYMBOLS



important information



3D file or preview available



you will need tools, sub parts, accessories



keep away from source of high temperature



warnings, important notes



use respiratory protective equipment



protect from noise or eye damage



switch off before proceeding

General information	3
Equipment arrival	3
Product application and reservations	3
Construction	4
Dimensions	4
Technical data	5
Fan performance curves	5
Installation	6
Start-up	7
Maintenance	7
Troubleshooting	8

General information

This instruction manual contains ZWR fan units use and maintenance information. ZWR fan user should become acquainted with contents of this publication to learn about unit construction, principles of operation and means of its safe use. Manufacturer is not responsible for any consequences arising from the use of the unit against its intended purpose. Manufacturer reserves the right to make changes to improve performance and operational qualities of the product in the future without prior notice.

Equipment arrival

Upon arrival the user needs to thoroughly inspect the equipment and make sure there was no damage caused by the shipping carrier. If there is damage, the user needs to immediately contact their dealer. Transport of the device on a pallet can be done with a manually lifted forklift or a self-propelled lift truck.

The user should ensure that the following parts are provided in the ZWR sets:

- user manual
- fan outlet fitting
- fasteners for a self assembly of the fan outlet fitting

In case of lack of any listed items, please contact the dealer.



If the package or device is damaged upon delivery the user needs to immediately contact the dealer and draw up a protocol with a representative of the shipping company (many shipping companies consider acceptance of the shipment to be sufficient to avoid liability for damage caused during shipping).

Product application and reservations

ZWR fans are designed for extraction of air from the dry dust (with particular emphasis on the processes of welding, grinding, polishing, pouring, dispensing, cutting metals and plastics). ZWR extraction fans are perfect for fume and dust extraction especially with at-point extraction products such as fume extraction arm, extension booms, sliding rails, car exhaust hose reels or hose drops. ZWR fan units can be operated without restriction in the technical areas intended for permanent human habitation.



Manufacturer does not recommend use of the unit for:

- extraction of aggressive fumes and gases (e.g. from acids, from alkaline, from soldering paste containing lithium)
- extraction of hot gases (more than 40°C/104°F continuously)
- extraction of cement, saw dust, wood dust etc.
- explosive environments or explosive substances/gases
- cleaning air from dusts containing asbestos, cadmium, beryllium, chemically aggressive dusts explosion prone.



Store in dry and airy rooms. Protect against possibility of shifting during transport.

Construction

1. Fan housing
2. Motor
3. Fan outlet fitting (for self assembly)
4. Outlet
5. Inlet

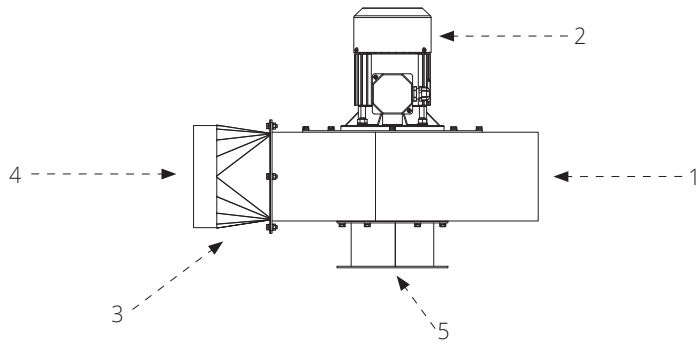

Dimensions

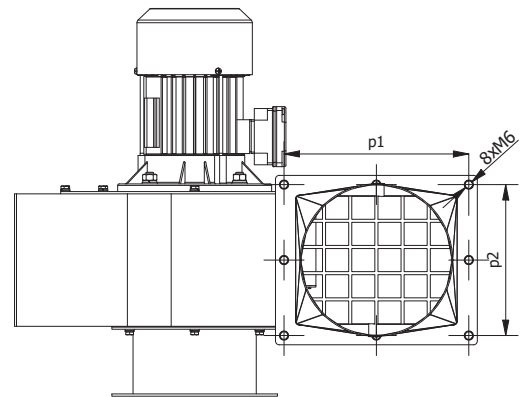
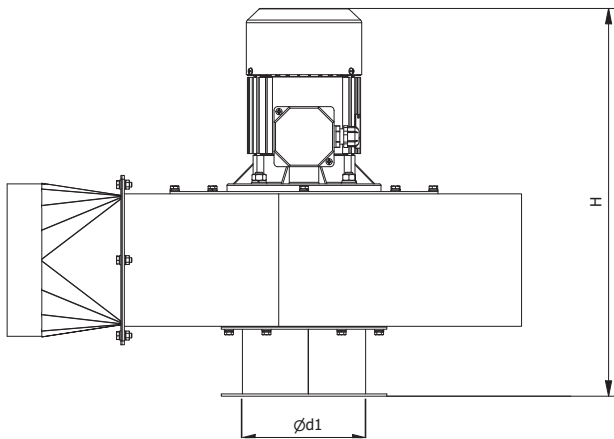
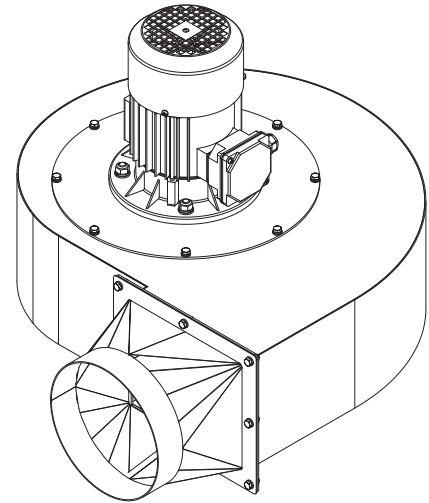
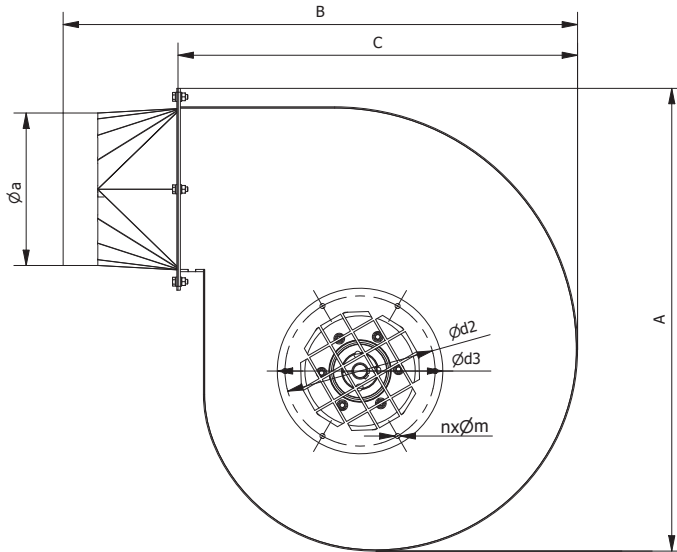

Fan	A [mm]	B [mm]	C [mm]	H* [mm]	d1 [mm]	d2 [mm]	d3 [mm]	a [mm]	p1 [mm]	p2 [mm]	n [qty.]	m [mm]
ZWR-03	537	609	465	483	160	195	215	160**	200	175	6	6,5
ZWR-04	601	668	519	504	160	195	215	200	240	196	6	6,5
ZWR-05	674	724	580	559	200	246	275	200	250	180	8	8,5

* Overall height can differ depending on configuration and motor supplier

** For fan with 460V and 110/220V motor, the diameter is 150mm

Technical data

Fan	Maximal airflow [CFM]	Power [HP]	Power supply [V] / [Hz]	RPM [1/min]	Degree of protection	Noise level* [dB(A)]	Weight [lbs]
ZWR-03	1130	1.5	3x208-230/480/60 (110/220)/60	3600	IP54	79	67
ZWR-04	1400	2	3x208-230/480/60 (110/220)/60	3600	IP54	81	89
ZWR-05	2120	3	3x208-230/480/60 (110/220)/60	3600	IP54	82	111

* The noise level may vary depending on the fan operating point



Maximum air temperature at the work place should not exceed 40°C. Fans with a three-phase motor, can cooperate with a frequency converter. The noise level is for a fan with ducted outlet and inlet.

Fan performance curves

ZWR -03-04-05 60Hz

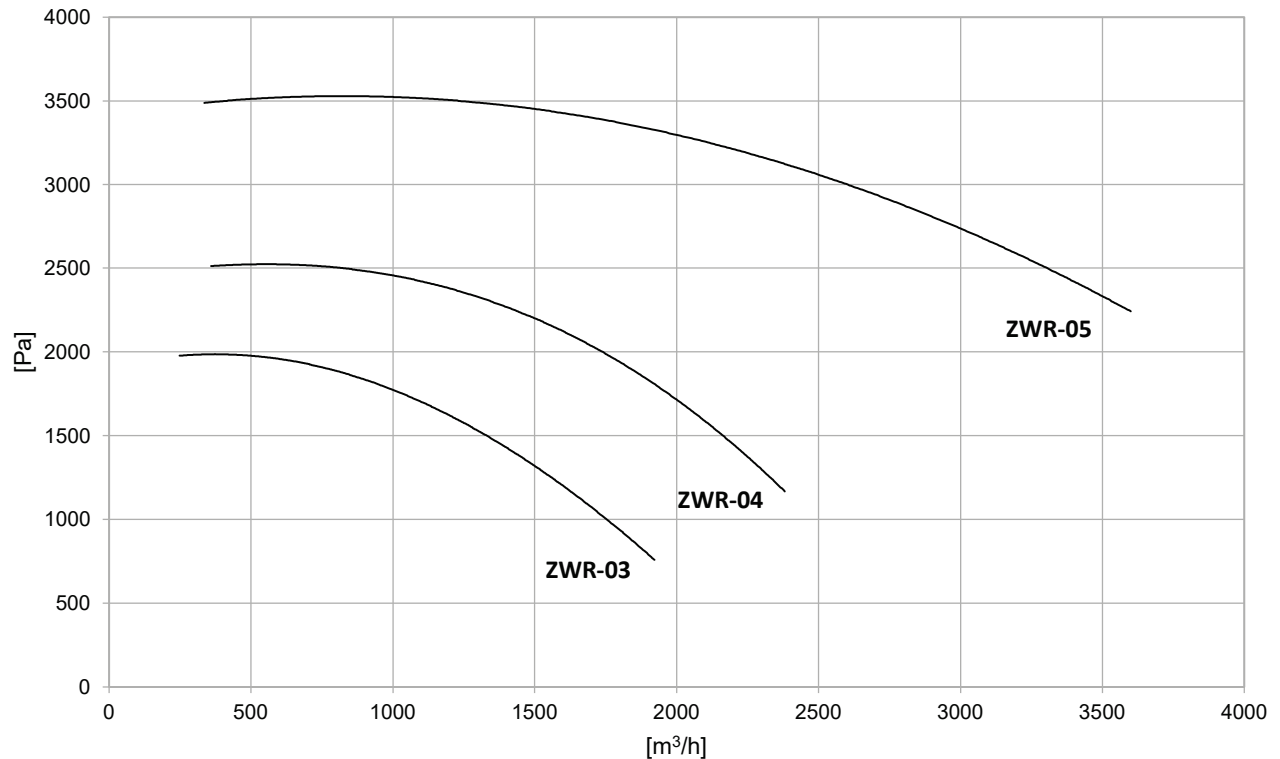

Installation

ZWR fan units are equipped with a connection flange (at the inlet), allowing installation directly to the mounting bracket and swivel of the extraction arm (available on separate order). The air outlet is adapted to be connected with circular ventilation ducts through the provided outlet fitting - it requires self assembly.

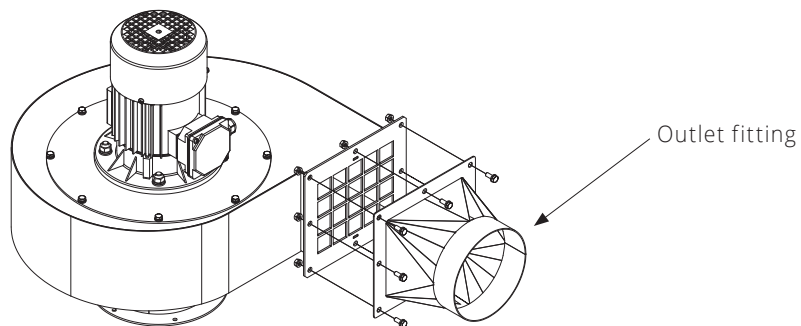

Use the fasteners included in the kit to screw the outlet fitting.

Start-up

The user of the ZWR connects the fan according to wiring diagram by the motor's junction box. Additionally the user, selects the appropriate type and cross section of electric wires and appropriate protection against short-circuits and overloads.



In case of fans equipped with three phase motor the incorrect sequence of phase cables in the power socket will cause improper rotation of the fan impeller and its efficiency. Check that the voltage and frequency of the power supply correspond to the parameters on the motor's rating nameplate.



Appropriate health and safety protection should be applied. All electrical work must be carried out by qualified personnel.

Maintenance

DAILY	MONTHLY	YEARLY
Overall control of connection tightness	Visual inspection for signs of corrosion	Inspection of electrical wiring Clean the interior of the device Check the cleanliness of the inlet grate



Appropriate health and safety protection should be applied. All electrical work must be carried out by qualified personnel

Troubleshooting

SYMPTOMS	POSSIBLE REASONS	PROCEDURE
Low air flow	Wrong motor rotation direction	Change direction of the motor by changing the phases in power supply socket
	Foreign objects (blocking the air flow) at the inlet grate	Disconnect the fan from the power supply system and remove the obstacle
Vibrations	Unbalanced impeller	Balance the fan to achieve the G 6.3 level in the AMCA standard or replace with a new one
	Worn or damaged bearings	Replace the bearings
	Loose bolts	Tighten the bolts
	Obstacle objects got stack at the impeller	Disconnect the fan from the power supply system and clean the impeller
Loud operation	Loose or damaged bearings	Replace the bearings
	Foreign item blocking the impeller	Remove the foreign item, clean the interior of the device and check the device for damage



Room capacity, partition walls material, architecture of the interior, installation place of the device and other installed machines may increase the total sound pressure level at workplace.



In case of discovering unusual phenomena such as increased noise, vibrations or smoke you should:

- disconnect the device from the power source*
- try to suppress the possible flame source by using a powder extinguisher*
- notify relevant services at the workplace*

Authorised representative