

PRODUCT NAME	Macaron	DESIGNER	Silvia Ceñal
---------------------	----------------	-----------------	---------------------

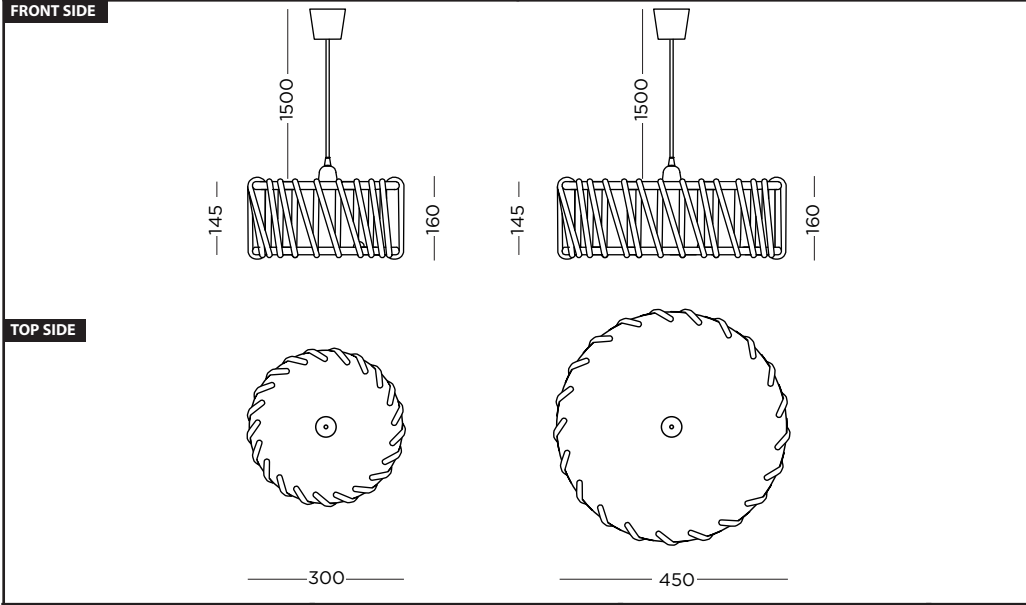

DIMENSIONS & WEIGHTS

Macaron D30
 General Dimensions : W.300, D.300, H.145mm, 1.5kg

package:
 W.335, D.325, H.190mm, 3kg

Macaron D45
 General Dimensions : W.450, D.450, H.145mm, 2.7kg

package:
 W.485, D.475, H.190mm, 4kg



CODE

MCH30black MCH30blue MCH30red MCH30white MCH30yellow



CODE

MCH45black MCH45blue MCH45red MCH45white MCH45yellow

PRODUCT DETAILS

Assembly -	Partial assembly required
Instruction Included-	Yes
Frame-	nonflammable MDF 12mm, oak veneered 6mm
Finish-	nonflammable lacquer SM3000-0025
Wooden sticks-	3 birch sticks, Ø8 mm stained oak color
Ceiling Lamp Base-	White plastic
Rope-	Ø8 mm, 7m; Duguva company
Lamp-	MAX 1x40 W
MACARON WHITE BULB NOT INCLUDED	
Lamp holder -	thermoplastic black E27
Cable-	1.5 m; Merlotti company
Package-	1 pcs.
Guarantee-	24 months



Lacquer certificate:

DIN 4102 -1

Testing certificate no. P-MPA-E-01-682

Determination of heat of combustior Qpcs according to DIN EN ISO 1716:2010

Cable certificate :

CEI 20-19 part 2 art.8 according to the standard document CENELEC HD 22.2 S2/92 art.8 for braid's heat resistance test.

CEI 20-20 Ed. 90 according to the standard document CENELEC HD 21.1 S2/92, 21.2 S2/92

and 21.3 S2/92 referred to H05V-K cables.

Certificate of following activites:

Desing and production of lampholders, household plugs and sockets, switches for appliances, connecting devices, semi lunaires, insulators, cord anchorages, low voltage PVC insulated cables, incandescent and halogen dimmer, electronic ballast for fluarescent lamps, led moduls, power supplies for led, led controllers and electronic systems for led.

Has implemented and maintance a quality management systems which fulfills requirements of following standard ISO 9001 : 2008

