

## Remote Control

- Patent Pending -



**Thank you for your purchase! Please read the instructions thoroughly BEFORE beginning the installation.**

<https://GeezerEngineering.com/pages/instructions>

Copyright © 2021 by GeezerEngineering LLC – All Rights Reserved  
Publication, duplication, or distribution prohibited without the written consent of GeezerEngineering LLC

GeezerEngineering Remote Control must be used exclusively with door openers manufactured after 1993 that utilize photoelectric sensors. The photoelectric sensors are always located at or near the bottom of the door track.

## Instructions

1. Installation on your motorcycle
2. Programming the sending unit of
  - A. garage door openers with 'Learn' or 'Programming' button
  - B. Fixed code garage door openers (typically older products)

### Note:

- **Make sure the harness is NOT pinched between switch and clutch control. Push it in together with the OEM harness and make sure it remains there. A pinched harness is NOT covered by our warranty. more information in our instructions and installation videos.**
- We recommend having a qualified professional workshop install this product.
- Original remote control or a clone programmed to your garage door opener. If you do not have a functioning remote control you will need to get one so you can copy its code into the GeezerEngineering Remote Control.
- Your GeezerEngineering Remote Control comes with a connector that plugs into the accessories port. The type of connector depends on the model and year you have ordered. If your motorcycle does not have an accessory port, we recommend having it added by a qualified professional workshop. We offer a 4-pin Deutsch connector with pigtail that can be spliced into your existing wiring harness. Make sure there is an adequately sized fuse inline factoring in all electrical accessories you may connect.
- Please use zip ties (not included) to secure harness and remote sending unit.
- Please do not disassemble any portion of your GeezerEngineering remote control as it will damage the waterproof seal. This voids the warranty.

## Installation on your motorcycle

**Tip:** Before installing everything on your motorcycle we suggest you plug the product together and into your accessory port. Then you can program the codes from your OEM remote control as described in chapter 2. Programming. It works either way but is more convenient because the remote sending unit is directly accessible.

**Installing the handlebar remote control switch** – it replaces the mounting bracket of your clutch control commonly found on Harley-Davidson motorcycles since model year 1996.

The round switch can be installed in Harley touring models with fairing in place of the power outlet (“cigarette lighter socket”) or in any flat panel after drilling a hole with 22mm or 7/8” diameter. This requires a hole saw (not included).

Handlebar switch:

Secure the clutch control assembly and remove the OEM mounting bracket. The two Torx 27 bolts will be reused to attach your GeezerEngineering handlebar switch. It is designed to either run the harness along the outside of the handlebars or on the inside. *In either case make sure to not pinch the harness when tightening the switch housing to the clutch control.* Many OEM handlebars are generously dimpled, and the harness should be easy to route safely towards the GeezerEngineering remote control sending unit. Certain aftermarket handlebars may require additional clearance. Make sure to remove any sharp edges that could be in contact with the harness to avoid damage. Also make sure the remote control harness does not interfere with any other parts to avoid damage and safety hazards. GeezerGlide remote controls include two peel-and-stick pads – one .5mm thickness and the other one is .8mm thick. These can be put on the inside of the remote control switch to add another layer of waterproofing. If needed, the pads also compensate for variances in handlebar diameters on some OEM and aftermarket handlebars. In most cases the .5mm pad will be the right size. Use zip ties to secure the harness on your handlebars.



<https://GeezerEngineering.com/pages/instructions>

Copyright © 2021 by GeezerEngineering LLC – All Rights Reserved

Publication, duplication, or distribution prohibited without the written consent of GeezerEngineering LLC



Round switch:

Remove outer fairing shell and remove power socket. Install round switch in the opening and route the switch harness to the location where the remote sending unit is installed.



If a new opening is drilled, please make sure it is accessible to complete the switch installation and that the areas behind is clear to avoid damage.

**Installing the remote control sending unit** – different Harley models and other vehicles offer different locations for the installation. As a general rule, it is best to install the remote sending unit in an accessible place in case programming is required. The remote control sending unit is

<https://GeezerEngineering.com/pages/instructions>

Copyright © 2021 by GeezerEngineering LLC – All Rights Reserved

Publication, duplication, or distribution prohibited without the written consent of GeezerEngineering LLC

completely waterproof and has no serviceable parts, so it doesn't need protection against the elements. Do not pressure wash the components as this could damage seals and damage the product. Our recommendations:

**Touring models:** many models and model years have a plastic caddy for the main wiring harness running along the backbone of the frame. A great location to install the remote control sending unit is at the very front inside of the caddy, right under the front of your fuel tank. It is a secure and hidden place but accessible for programming.

- Refer to your OEM service manual on how to remove seat and tank.
- Carefully pry open the harness caddy.



- Plug the switch harness (6-pin, keyed) into the black connector on the sending unit. Make sure to line up the keys properly. There's a small arrow on both harness plugs that make alignment easy. The plug sits tight to ensure it is waterproof. Please ensure proper alignment and do not use excessive force as pins may get bent or broken off. This kind of damage is not covered by our warranty.





- Plug the power harness (3-pin, keyed, orange inside) into the orange color connector and route the power harness from the front of the harness caddy towards the starter battery.
- Secure both harnesses and the remote sending unit with zip ties.
  - Note: To prevent wear and to maintain waterproof connections please keep the number of times you plug and unplug the harnesses to an absolute minimum.

- **1996-2013 Touring:** locate the accessory Deutsch connector in front of the starter battery and plug in the power harness. If you've never used it – look for a Deutsch connector with a rubber plug in it:



- Excess harness length is best hidden in the area in front of the starter battery. Secure with zip ties.



- **2014-2016 Touring:** The connector is blind-plugged into the battery box, on the right side under the side cover and under your ABS pump. Carefully pry back the retainer clip on the connector and pull the connector out of the receptacle. Picture of the location:

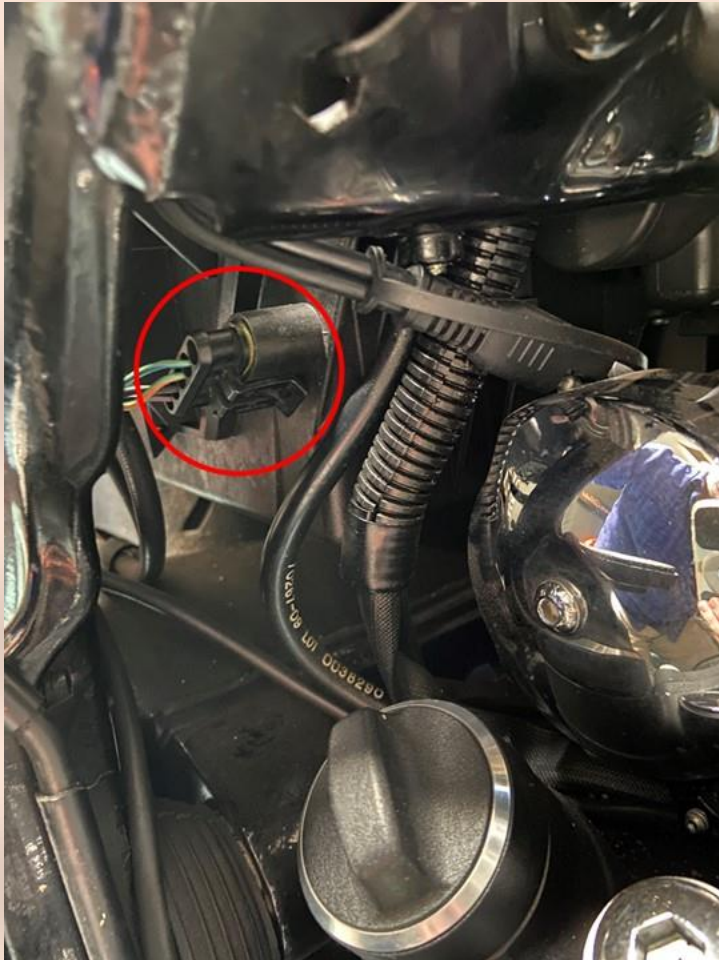

- **2017-later Touring:** The connector is blind-plugged into the battery box, right next to your ABS pump. Carefully pry back the retainer clip on the connector and pull the connector out of the receptacle. Picture of the location:

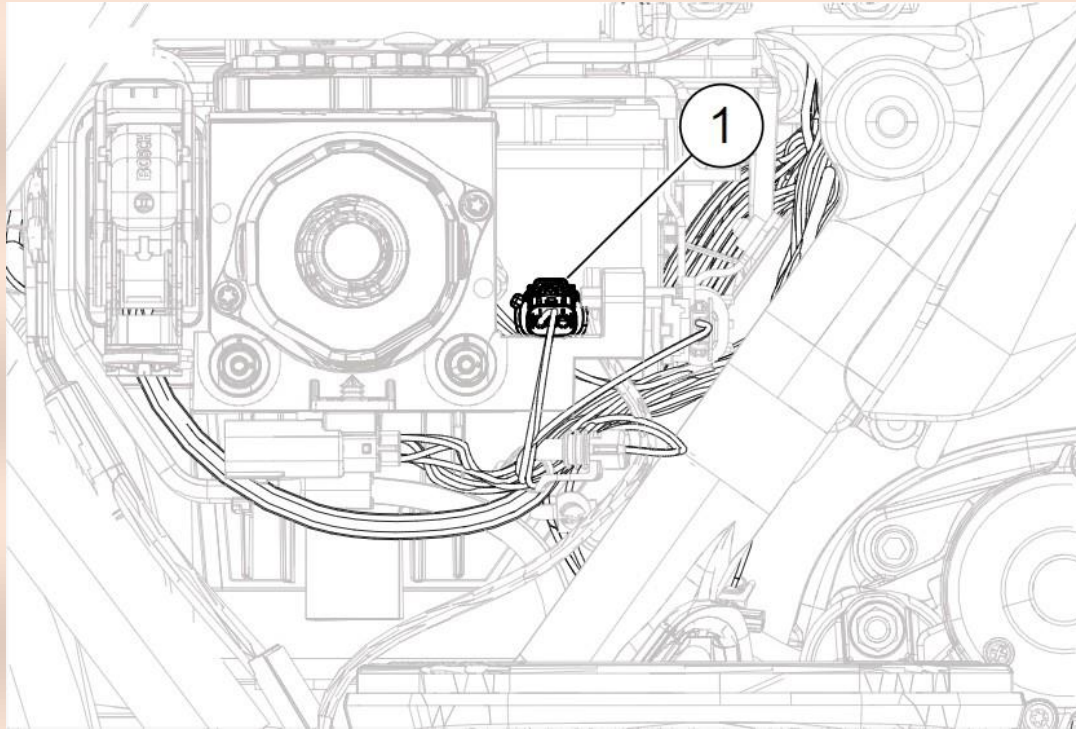

- Check that all parts are secured properly, route the blue antenna wire to the outside left (clutch side) and reinstall the top of the harness caddy.
- We suggest securing the antenna wire with a zip tie or a piece of black electric tape. The antenna wire optimizes the reach of your GeezerEngineering remote control signal.
- The installation is complete. Before reinstalling tank and seat, we recommend proceeding to programming your GeezerEngineering remote control.
- Once programming is complete reinstall seat and tank according to instructions in your OEM service manual.

## 2017-later Softail models

Use the same connector as 2017-up touring models but the connector is located under the left side cover in the seat area:

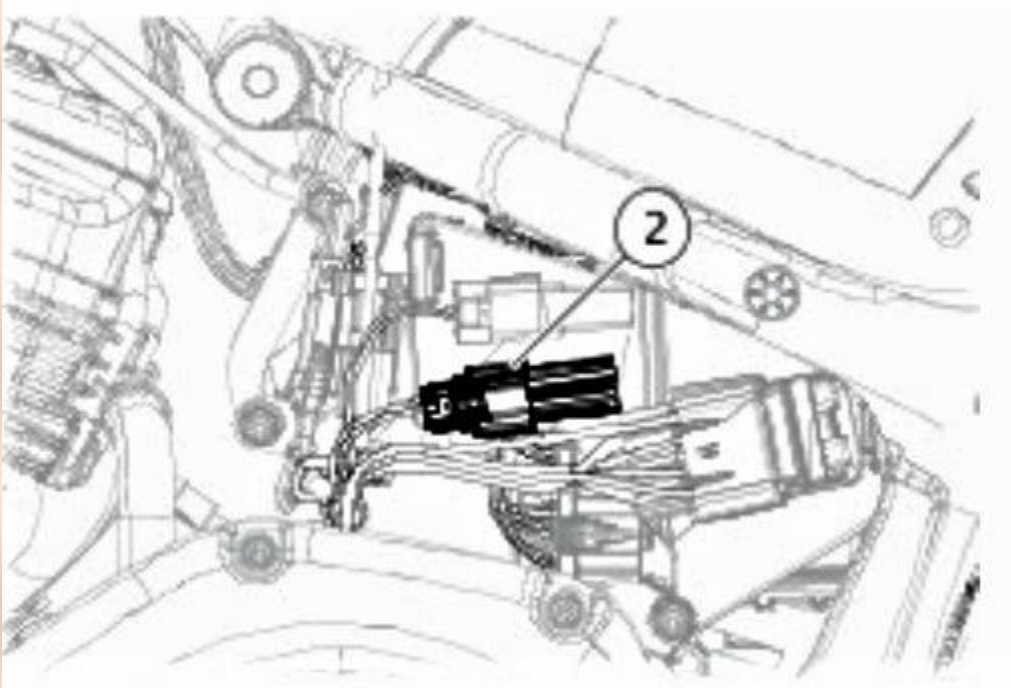

**Dyna** models – shown on 2016 FXDB Street Bob

Pictures and description curtesy of our customer Bob Odenkirk Thanks!!! 'I installed mine on a 2016 FXDB Street Bob. It's attached to the frame of the motorcycle underneath the gas tank on the right hand side. Just behind the wire grommet. I also wired it internally in the handlebars.'

<https://GeezerEngineering.com/pages/instructions>

Copyright © 2021 by GeezerEngineering LLC – All Rights Reserved

Publication, duplication, or distribution prohibited without the written consent of GeezerEngineering LLC





<https://GeezerEngineering.com/pages/instructions>



<https://GeezerEngineering.com/pages/instructions>

Copyright © 2021 by GeezerEngineering LLC – All Rights Reserved

Publication, duplication, or distribution prohibited without the written consent of GeezerEngineering LLC





Well done, Bob! And thanks again for sharing your project pictures.



**Softail** models 2011 - 2016 use a 6-pin Deutsch connector that is located under the left side cover below the seat. Also used on 15-later XG, 14-later XL, 12-17 FXD

**Softail** models 2017 - later use the same 3-pin Molex connector as 2017 – later touring models. The connector that is located under the left side cover below the seat

Evo-style: install between tanks under the dash cover



**Sportster** models – t.b.d.

**VRSC** models – t.b.d.

<https://GeezerEngineering.com/pages/instructions>

Copyright © 2021 by GeezerEngineering LLC – All Rights Reserved

Publication, duplication, or distribution prohibited without the written consent of GeezerEngineering LLC

If you have found a great location for the sending unit on your bike, we'd love to know about it. We'll be happy to include your pictures on our web site or in these instructions. Please email [contact@GeezerEngineering.com](mailto:contact@GeezerEngineering.com) with year, model and pictures.

<https://GeezerEngineering.com/pages/instructions>

Copyright © 2021 by GeezerEngineering LLC – All Rights Reserved

Publication, duplication, or distribution prohibited without the written consent of GeezerEngineering LLC

# Programming

- a. On your GeezerEngineering handlebar switch we refer to the top button as button 1, the one at the bottom is button 2.
- b. On our round switch product the left button is button 1 and the right is button 2.
- c. There are two LED's built in. The **blue** LED flashes every time a button is pushed to indicate it is sending a signal. The **red** LED is **only** used in programming mode.
- d. GeezerEngineering Remote Control is a multi-frequency cloning device, meaning a remote control that is set up to control your garage door opener is required so its code can be transferred into your GeezerEngineering Remote Control.
- e. GeezerEngineering Remote Control can be used with hundreds of models and brands of electric door openers. This manual describes how to program GeezerEngineering Remote Control of the most commonly installed garage door openers in North America, among those are: Chamberlain, LiftMaster, Craftsman, Genie, Overhead Door and other compatible brands and models. For a complete list of compatible products and brands please contact us or download our list at <https://GeezerEngineering.com/pages/instructions>

## Notes:

- As with any remote control – at any time when using your *GeezerEngineering Remote Control* always make sure your garage door is clear of any obstructions and no person is near it to avoid damage to property, bodily injuries or even death.
- The remote control sending unit is IP67 waterproof so it can be safely installed in a location on your motorcycle where it is exposed to water. The control switches are designed to comply with at least IP65 rating. Please avoid hitting the switches with high pressure water as it may damage the seal. This type of damage is NOT covered by our warranty.
- *GeezerEngineering Remote Control* can be re-programmed whenever needed.





Garage door openers with “LEARN” button (*Chamberlain, LiftMaster, Genie, Sears Craftsman, Do-it, Raynor and many others*)

## DUPLICATING PROCEDURE

1. Set ignition switch to the ON position (if the accessory power port is used)
2. While pressing button 1 of the handlebar or round switch (**blue** LED lights up), press button 2 four times. Now the **red** LED emits a flash every 2 seconds.
3. Release both buttons. Your GeezerEngineering remote control is now in programming mode. (The sending unit will exit programming mode automatically after a while. If that occurs repeat from 2.).
4. While the **red** LED is flashing place the original remote control close to the GeezerEngineering remote sending unit installed on your bike at about 1” – 2” of distance.
5. Press and retain pressing the button of the original remote control you want to copy until the GeezerEngineering remote's **red** led will turn off and the **blue** LED blinks. This confirms the code of your original remote control has been copied into the memory of your GeezerEngineering remote control sending unit.

*Note: if the **red** LED does not go out and the **blue** LED is not coming on then programming has to be repeated. In this case repeat the previous steps. Try turning the OEM remote control as its internal antenna may be too far away from the GeezerEngineering remote sending unit. In some cases, disconnecting power from the GeezerEngineering and then reconnecting it helps as this resets it. If this is not successful, please change the battery on your OEM remote control.*

6. Immediately press and hold the handlebar switch of your GeezerEngineering Remote Control you want to store the original remote code you just copied until the LED turns off.
7. After successfully finishing up the procedure it is time to ‘introduce’ your GeezerEngineering Remote Control to the receiver of your garage door opener. Please push the “LEARN” button if applicable or by following the manufacturer’s procedure in the respective

<https://GeezerEngineering.com/pages/instructions>

Copyright © 2021 by GeezerEngineering LLC – All Rights Reserved  
Publication, duplication, or distribution prohibited without the written consent of GeezerEngineering LLC

owner's manual for your garage door opener. On this rolling code model of a Chamberlain garage door opener (left) the “LEARN” button is purple and on the LiftMaster units used in our workshop on the right it is yellow. Our Genie test unit has a “PRGM” button.

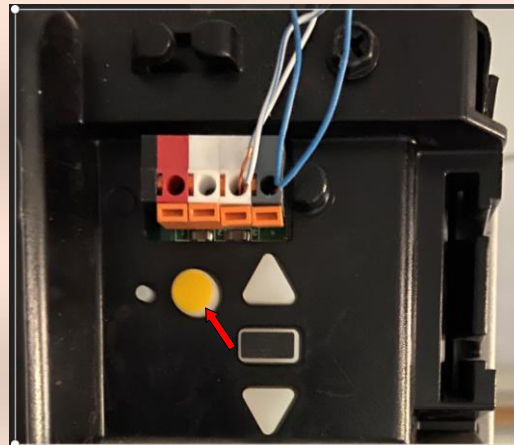
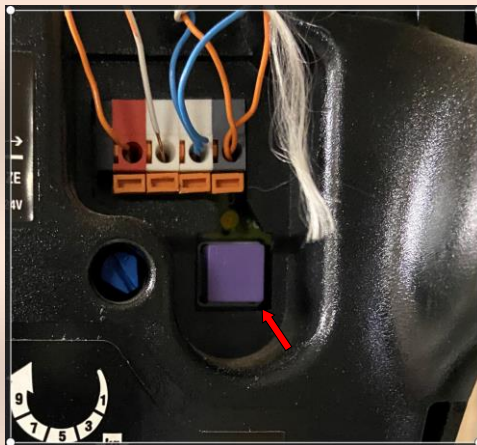

The procedure of programming is identical but activation of programming or “LEARN” mode on the garage door openers varies slightly. Pushing the “LEARN” button once initiates our Chamberlain and LiftMaster units’ programming mode. Our Genie test unit needs a push and hold on the “PRGM” button to do the same. Please refer to the manufacturer’s instructions for further information on the ‘learn’ or programming function. The described procedures in these instructions are meant as examples to illustrate the concept. In most cases this will be sufficient to program your GeezerEngineering Remote Control. Please note that different brands and models may have different colors for the “LEARN” button on the garage door opener. There is a list of garage door opener brands and models compatible with GeezerEngineering remote control available for download at

<https://GeezerEngineering.com/pages/instructions>

8. After pushing the “LEARN” button the garage opener will temporarily stay in “LEARN” mode, usually for about 30 seconds (LED lit or blinking), please push the button on your GeezerEngineering handlebar switch you just programmed until your garage door opener flashes, beeps or both. Programming is complete. To program the second button please repeat all steps until complete.

<https://GeezerEngineering.com/pages/instructions>

Copyright © 2021 by GeezerEngineering LLC – All Rights Reserved  
Publication, duplication, or distribution prohibited without the written consent of GeezerEngineering LLC

Note: to disable the programmed code follow steps 1) through 6) using your OEM remote control *but do not push the “LEARN” button on your garage door opener*. This generates a new rolling code for your GeezerEngineering remote control, which is not known to the garage door opener.



**FIXED CODE** (no “LEARN” button, typically older models) - if your garage door opener has a ‘LEARN’ button please skip this section and proceed to the next section

## DUPLICATING PROCEDURE

1. Set ignition switch to the ON position (if the accessory power port is used)
2. While pressing the button 1 of the switch (**blue** LED lights up), press button 2 four times. Now the **red** LED emits a flash every 2 seconds.
3. Release both buttons. Your GeezerEngineering remote control is now in programming mode. *(The sending unit will exit programming mode automatically after a while. If that occurs repeat from 2.)*
4. While the **red** LED is flashing place the original remote control close to the GeezerEngineering remote control sending unit installed on your bike at about 1” – 2” of distance.
5. Press and retain pressing the button of the original remote control you want to copy until the GeezerEngineering remote's **red** led turns off and the **blue** LED blinks. This confirms the code of your original remote control has been copied into the memory of your GeezerEngineering remote control sending unit.
6. While the **blue** LED is flashing, press the handlebar button of your GeezerEngineering remote control (button 1 or button 2) you want to store the original remote code to. Keep the button pressed until the LED turns off.

*Note: if the **red** LED does not go out and the **blue** LED is not coming on then programming has to be repeated. In this case repeat the previous steps. Try turning the OEM remote control as its internal antenna may be too far away from the GeezerEngineering remote sending unit. In some cases, disconnecting power from the GeezerEngineering and then reconnecting it helps as this resets it. If this is not successful, please change the battery on your OEM remote control.*

7. Programming is complete. Please verify proper function of your GeezerEngineering remote control.

### Note:

- *If the **red** LED flashes only 3 times and then turns off, then the code hasn't been copied properly. In this case please repeat the procedure from the beginning. Make sure to hold your original remote control no further away than 2” from the GeezerEngineering remote control sending unit.*
- *The memory of the remote is completely re-writable - you can reprogram the remote any time with a different code.*
- *To duplicate a second button, repeat the procedure.*
- *Fixed code garage door openers do not have a “LEARN” button on the receiver part of the garage door opener.*

<https://GeezerEngineering.com/pages/instructions>

Copyright © 2021 by GeezerEngineering LLC – All Rights Reserved  
Publication, duplication, or distribution prohibited without the written consent of GeezerEngineering LLC

# Disclaimer

GeezerEngineering products part numbers, product packaging and corresponding printed matter are not intended to imply that any of these parts are Harley-Davidson® original equipment or endorsed by Harley-Davidson® Inc. The words, Enforcer, Rushmore, Buddy Seat, Disc Glide, Dyna Glide®, Electra Glide®, Evolution®, Fat Boy®, HD®, H-D®, Harley®, Harley-Davidson® Heritage® Softail®, Heritage® Springer®, Hugger®, Low Rider, Night Train®, Road Glide®, Road King®, Roadster®, Softail®, Softail® Deuce™, Sport Glide®, Sportster®, Springer®, Sturgis®, Super Glide®, Tour-Pak, Tour Glide®, Ultra Classic™ and Wide Glide® are registered trademarks of Harley-Davidson®, Inc., Milwaukee, Wisconsin, U.S.A. The words, Bad Boy®, Convertible, Duo Glide®, Hydra Glide®, V-Fire III and VROD™ are trademarks of Harley-Davidson®, Inc., Milwaukee, Wisconsin, U.S.A.

The following model designations for Harley-Davidson® motorcycles are used on this website for reference only: EL, FL, FLH, FLHR, FLHRCI, FLHS, FLHT, FLHTC, FLHTC Ultra Classic, FLHTC-I, FLHTCUI, FLHX, FLST, FLSTC, FLSTF, FLSTN, FLSTS, FLSTSC/I, FLT, FLTC, FLTC Ultra Classic, FLTCU, FLTR, FLTRI, FLTRSEI, FX, FXB, FXD, FXDB, FXDC, FXDG, FXDL, FXDS-CON, FXDWG, FXDX, FXDXT, FXE, FXEF, FXLR, FXR, FXRC, FXRD, FXRDG, FXRP, FXRS, FXRS-CON, FXRSE, FXRS-SP, FXRT, FXS, FXSB, FXST, FXSTB, FXSTC, FXSTD, FXSTD-I, FXSTS, FXSTSB, FXWG, GE, K, KH, VROD™, VRSCA, VRSCB, WL, WLA, XL, XL1100, XL1200, XL1200C, XL1200R, XL1200S, XL883, XL883C, XL883R, XLCH, XLCR, XLH, XLH1100, XLH1200, XLH1200, XLH1200S, XLH883, XLR, XLS, XLS, XLT, XLX, XLX, XR1000 and their connection to Harley-Davidson® factory part numbers, as well as any printed matter, are not intended to imply that any of these parts are Harley-Davidson® original equipment. Although the quality of most of the items listed here equals or exceeds OEM specifications, none of these items are manufactured by Harley-Davidson® Motor Company.

**All parts listed on the GeezerEngineering.com website are either designed by GeezerEngineering or from independent aftermarket sources. All GeezerEngineering products are aftermarket products and are not necessarily endorsed or recommended by any other manufacturer. None of GeezerEngineering branded parts illustrated were manufactured by the original equipment manufacturer of the motorcycles they are intended for or under their supervision or control.**

**All other brand names or trademarks or registered trademarks used in any GeezerEngineering publication are the property of their respective holders and are used for reference purposes only. GeezerEngineering is in no way, shape or form associated with Harley-Davidson® Motor Company – neither stated nor implied. Any products with a trademark, name, word, O.E.M. number used on our web site, digital documents, printed media and videos by GeezerEngineering is strictly intended to be used solely as a reference only to usage to that particular part. All GeezerEngineering parts are designed to comply with or exceed D.O.T. standards. None of the parts and accessories are D.O.T. approved unless noted otherwise. We have total confidence in our product quality. We strongly suggest test fitting all parts prior to any modifications or painting.**

To comply with FCC and or Industry Canada (IC) rules, adjustment or modifications of this device are prohibited, except for changing the code setting. THERE ARE NO USER SERVICEABLE PARTS. GeezerEngineering remote control has been tested to comply with FCC Standards FOR HOME OR OFFICE USE. FCC Part 15.19 Operation is subject to the following two conditions:

1. this device may not cause harmful interference, and
2. this device must accept any interference received, including interference that may cause undesired operations.

<https://GeezerEngineering.com/pages/instructions>

Copyright © 2021 by GeezerEngineering LLC – All Rights Reserved  
Publication, duplication, or distribution prohibited without the written consent of GeezerEngineering LLC