

PARTS			
PART	DESCRIPTION	PART NO.	QTY
A	LEFT SIDE ASSEMBLY	SA-00286	1
B	RIGHT SIDE ASSEMBLY	SA-00287	1
C	SPREADER	PRT-00580	4
D	TABLE TOP ASSEMBLY	SA-00284	1

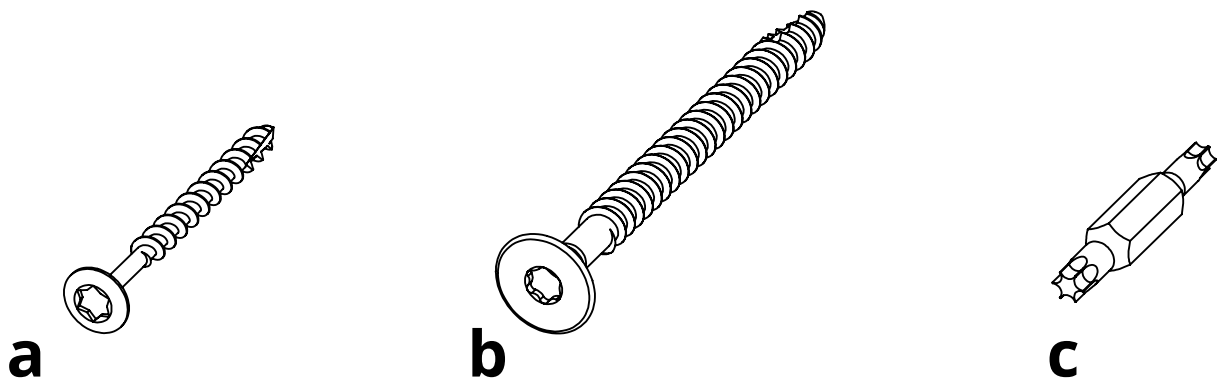

HARDWARE			
PART	DESCRIPTION	PART NO.	QTY
a	#8 X 2" TORX SCREW	H-0000-S82	4
b	1/4-10 x 3" LAG	H-0000-S103	10
e	T20 & T25 TORX BIT	H-0000-CTD	1

Suggested Tools: Drill, Plastic Mallet

Please read entire instructions before beginning

1. Attach Part C to Part B using Hardware b

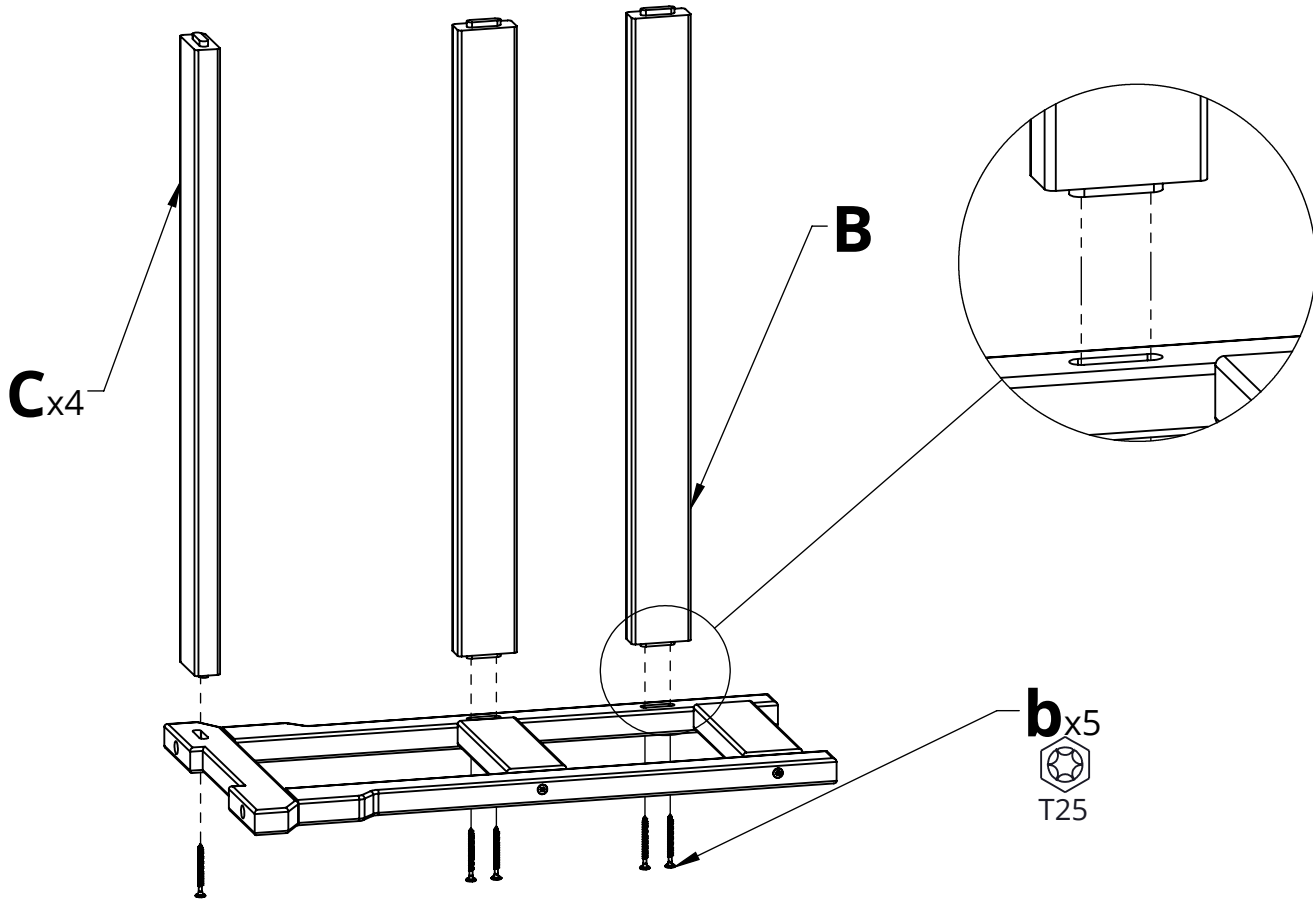

2. Attach Part A to assembled piece from Step 1;
Repeat Step 1

3. Attach assembled piece from Step 2 onto Part D using Hardware a

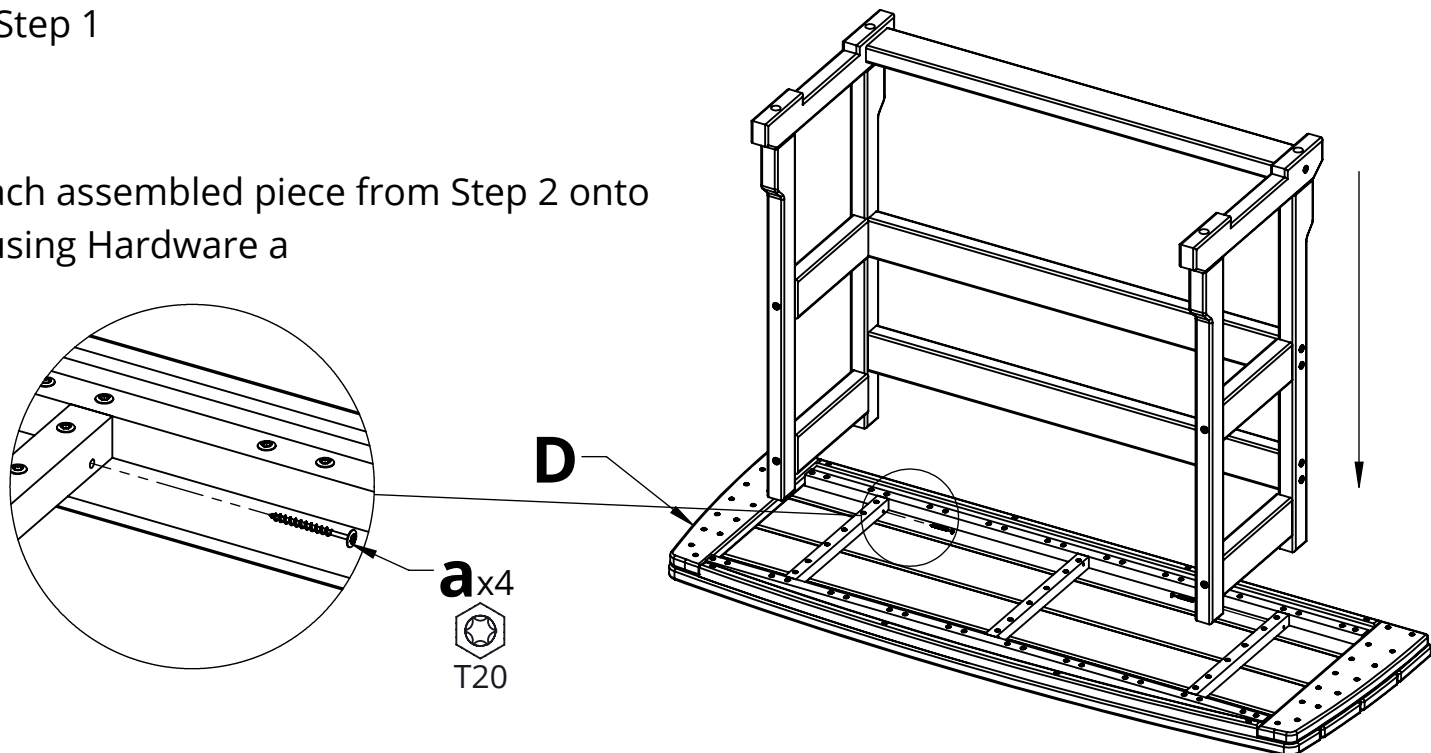

May be easier if assembled upside down