

DESPIECE

DISASSEMBLY



ACTUADOR NEUMÁTICO DE ALUMINIO
ALUMINIUM PNEUMATIC ACTUATOR



PA70: Doble Efecto / Double Acting
PA70S: Simple Efecto / Spring Return

Nº	Descripción Description	Cant. Quant.	Material Material
1	TORNILLO ALLEN ALLEN SCREW	20	ACERO INOXIDABLE AISI-304 AISI-304 STAINLESS STEEL
2	TAPA CAP	2	ALEACIÓN ALUMINIO (2) + (1) ALUMINIUM ALLOY (2) + (1)
3	JUNTA TÓRICA TAPA CAP-O-RING	2	N.B.R. N.B.R.
4	ÉMBOLO PISTON	2	ALEACIÓN ALUMINIO ALUMINIUM ALLOY
5	CILINDRO CYLINDER	1	ALEACIÓN ALUMINIO (2) + (1) ALUMINIUM ALLOY (2) + (1)
6	ARANDELA WASHER	1	POLIAMIDA 6 POLYAMIDA 6
7	ANILLO DE SEGURIDAD SPRING CLIP	1	ACERO (2) STEEL (2)
8	INDICADOR VISUAL POSITION INDICATOR	1	POLIAMIDA POLYAMIDE
9	GUIA ÉMBOLO PISTON GUIDE	4	NYLON NYLON
10	ANILLO GUIA GUIDE RING	2	P.T.F.E + BRONCE P.T.F.E + BRONZE
11	JUNTA TÓRICA ÉMBOLO PISTON O-RING	4	N.B.R. N.B.R.
12	JUNTA TÓRICA EJE SHAFT O-RING	2	N.B.R. N.B.R.
13	JUNTA TÓRICA EJE SHAFT O-RING	2	N.B.R. N.B.R.
14	MUELLES PRECARGADOS PRELOADED SPRINGS	12	DIN-17223-C (2) (4) DIN-17223-C (2) (4)
15	LEVA CAM	1	ACERO (2) STEEL (2)
16	EJE SHAFT	1	ACERO (2) STEEL (2)
17	JUNTA TÓRICA PLACA PLATE O-RING	2	N.B.R. N.B.R.
18	JUNTA TÓRICA TAPA CAP O-RING	2	N.B.R. N.B.R.
19	PLACA CONEXIÓN NEUMÁTICA PNEUMATIC CONNECTION PLATE	1	ACERO INOXIDABLE CF8M CF8M STAINLESS STEEL
20	TORNILLO ALLEN PLACA PLATE ALLEN SCREW	2	ACERO INOXIDABLE AISI-304 AISI-304 STAINLESS STEEL
21	TORNILLO HEXAGONAL HEXAGONAL SCREW	2	ACERO (3) STEEL (3)
22	TUERCA NUT	2	ACERO INOXIDABLE AISI-304 AISI-304 STAINLESS STEEL
23	ARANDELA BUSHING	2	ACERO INOXIDABLE AISI-303 AISI-303 STAINLESS STEEL
24	JUNTA TÓRICA O-RING	2	N.B.R. N.B.R.
25	PIÑÓN GEAR	1	ALEACION DE ALUMINIO (5) ALUMINIUM ALLOY (5)
26	ARANDELA WASHER	20	ACERO INOXIDABLE AISI-304 AISI-304 STAINLESS STEEL
27	ARGOLLA HOOP	2	ACERO INOXIDABLE AISI-304 AISI-304 STAINLESS STEEL

- (1) RECUBRIMIENTO CON POLIAMIDA.
COVERED WITH POLYAMIDE.
- (2) RECUBRIMIENTO POR CATAFORESIS.
COVERED BY CATHAPHORESIS.
- (3) PASIVADO DE CROMO TRIVALENTE.
TRIVALENT Cr PASSIVATION.
- (4) CANTIDAD VARIABLE. CONSULTAR
TABLAS PARES SIMPLE EFECTO.
VARIABLE QUANTITY, PLEASE SEE THE
SPRING RETURN TORQUE CHART.
- (5) BRUÑIDO CON BOLAS.
BALL BURNISHING.

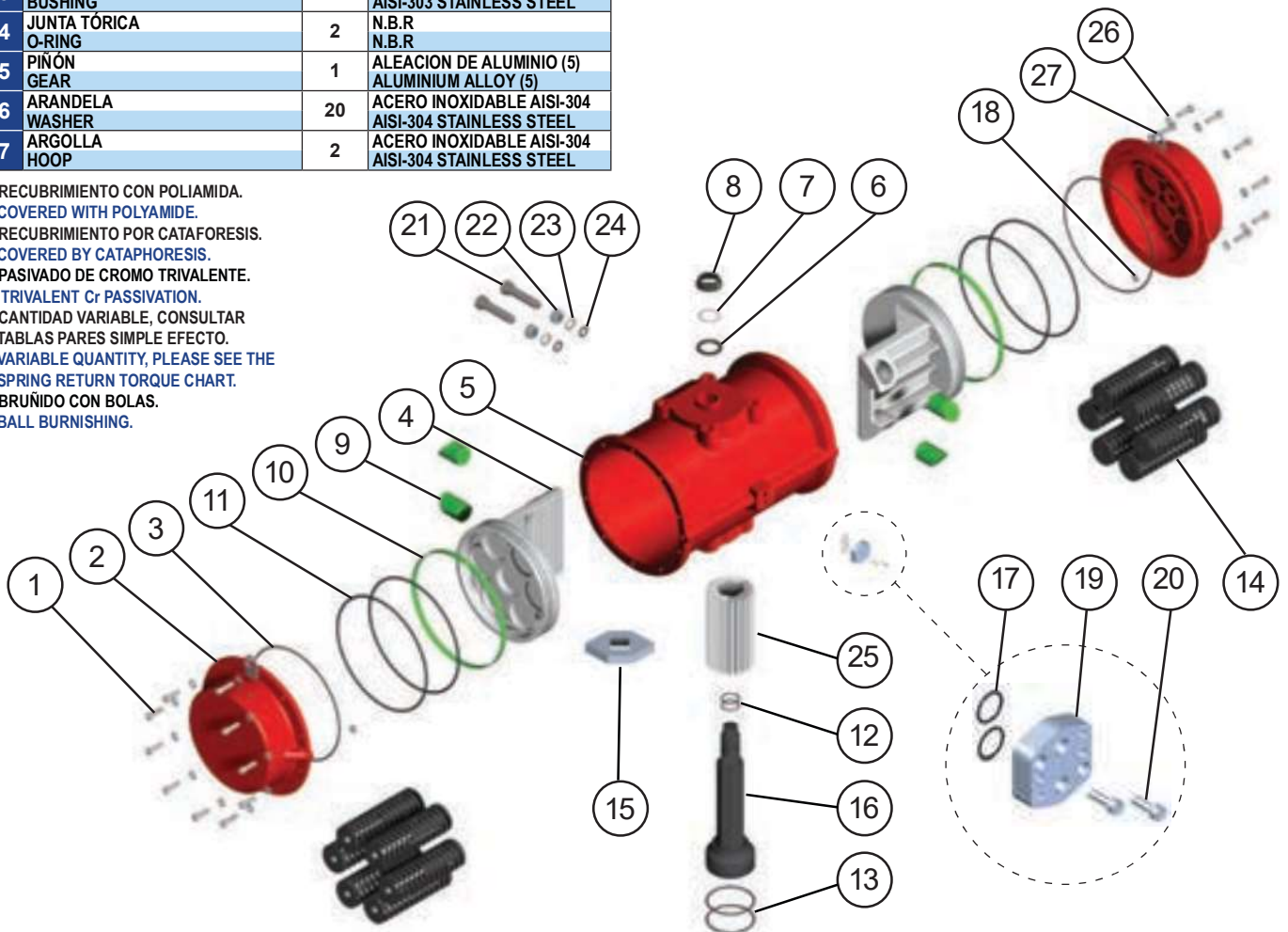

MODELOS MODELS	TIEMPO DE MANIOBRA EN SEG. CYCLE TIME IN SECS.		PESOS WEIGHTS		CAPACIDAD EN LITROS CAPACITY IN LITRES	
	PARA ABRIR TO OPEN	PARA CERRAR TO CLOSE	Kg.	Lb.	PARA ABRIR TO OPEN	PARA CERRAR TO CLOSE
PA70	4	4	77,9	171,74	31	30
PA70S	8	6	118,2	260,59	31	

Tiempo de maniobra sin par resistente a 6 bar.
Cycle time w/o resistant torque at 6 bar.

Dimensiones en mm.
Dimensions in mm.

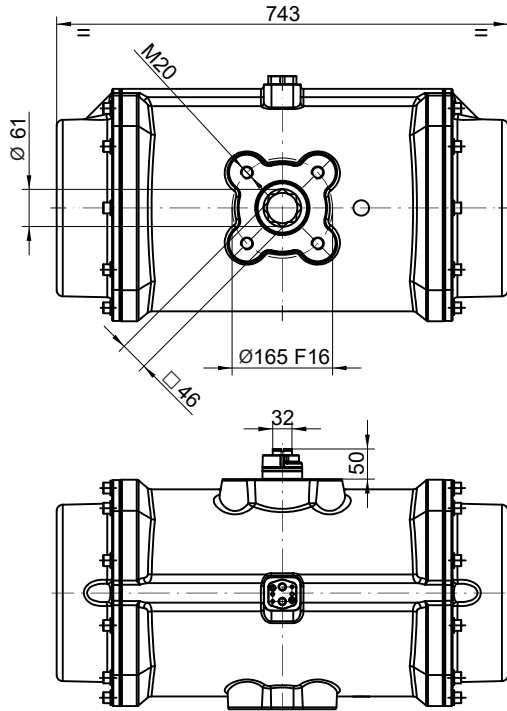

Para calcular el consumo, multiplicar las cifras del cuadro por la presión real de trabajo.

To calculate the consumption, multiply the above figures by the real working pressure.

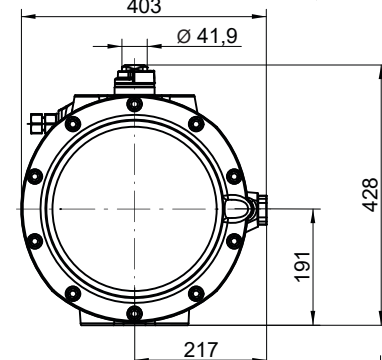
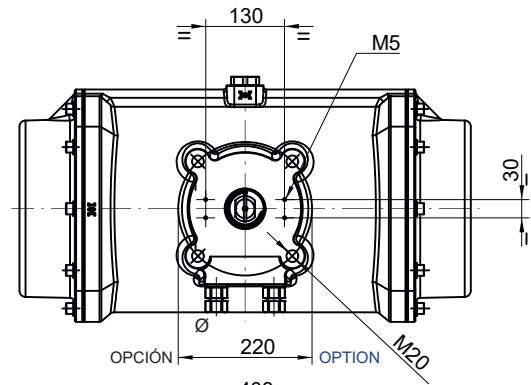

PARES DOBLE EFECTO DOUBLE ACTING TORQUES

PA70	PRESION AIRE AIR PRESSURE							
bar	3	4	4,5	5	5,5	6	7	8
p.s.i	43,5	58	65,3	72,5	79,8	87	101,5	116
Nm	2.389	3.273	3.715	4.158	4.600	5.043	5.927	6.812
Lb.in	21.141	28.971	32.886	36.801	40.716	44.631	52.461	60.291

NORMA NAMUR E.V
SOLENOID NAMUR NORM

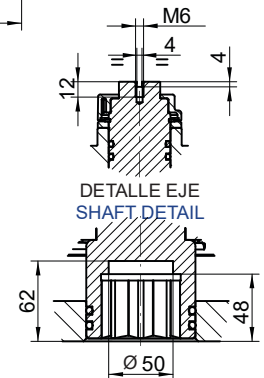
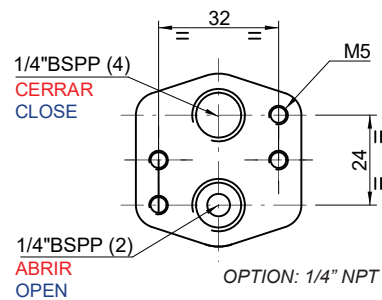

PARES SIMPLE EFECTO SPRING RETURN TORQUES

PA70S	PAR MUELLES SPRING TORQUES		PAR A LA PRESIÓN INDICADA AIR TORQUE AT INDICATED PRESSURE																bar
			3		4		4,5		5		5,5		6		7		8		
N	INICIAL INITIAL	FINAL END	INICIAL INITIAL	FINAL END	INICIAL INITIAL	FINAL END	INICIAL INITIAL	FINAL END	INICIAL INITIAL	FINAL END	INICIAL INITIAL	FINAL END	INICIAL INITIAL	FINAL END	INICIAL INITIAL	FINAL END	INICIAL INITIAL	FINAL END	
6*	3.539	1.769							2.389	619	2.831	1.062	3.273	1.504	4.158	2.389	5.043	2.273	Nm
	31.320	15.660							21.142	5.481	25.056	9.396	28.971	13.311	36.801	21.141	44.632	28.971	Lb.in
5	2.949	1.475					2.240	766,5	2.684	1.209	3.126	1.651	3.568	2.094	4.453	2.978	5.338	3.683	Nm
	26.100	13.050					19.836	6.786	23.751	10.701	27.666	14.616	31.580	18.531	39.411	26.361	47.241	34.191	Lb.in
4	2.359	1.180			2.094	914	2.535	1.356	2.978	1.799	3.421	2.241	3.863	2.684	4.748	3.568	5.632	4.453	Nm
	20.880	10.440			18.531	8.091	22.446	12.006	26.361	15.922	30.276	19.836	34.190	23.751	42.021	31.581	49.851	39.411	Lb.in
3	1.769	885	1.504	619	2.389	1.504	2.830	1.946	3.273	2.389	3.716	2.831	4.158	3.273	5.043	4.158			Nm
	16.660	7.830	13.311	5.481	21.141	13.311	25.056	16.226	28.971	21.142	32.886	25.056	36.800	28.971	44.631	36.801			Lb.in
2	1.180	590	1.799	1.209	2.684	2.094	3.125	2.535	3.568	2.978	4.011	3.421	4.453	3.863					Nm
	10.440	5.220	15.921	10.701	23.751	18.531	27.666	22.446	31.581	26.361	35.496	30.276	39.411	34.190					Lb.in

N: Número de muelles por banda
Number of springs per side

* Número de muelles estándar
* Standard number of springs