

DESPIECE

DISASSEMBLY

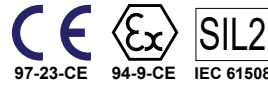

Nº	Descripción Description	Cant. Quant.	Material Material
1	TORNILLO ALLEN ALLEN SCREW	12	ACERO INOXIDABLE AISI-304 AISI-304 STAINLESS STEEL
2	TAPA CAP	2	ALEACIÓN ALUMINIO (2) + (1) ALUMINIUM ALLOY (2) + (1)
3	JUNTA TÓRICA TAPA CAP-O-RING	2	N.B.R. N.B.R.
4	ÉMBOLO PISTON	2	ALEACIÓN ALUMINIO (2) ALUMINIUM ALLOY (2)
5	CILINDRO CYLINDER	1	ALEACIÓN ALUMINIO (2) + (1) ALUMINIUM ALLOY (2) + (1)
6	ARANDELA WASHER	1	POLIAMIDA 6 POLYAMIDA 6
7	ANILLO DE SEGURIDAD SPRING CLIP	1	ACERO (2) STEEL (2)
8	INDICADOR VISUAL POSITION INDICATOR	1	POLIAMIDA POLYAMIDE
9	GUIA ÉMBOLO PISTON GUIDE	4	P.T.F.E + CARBONO P.T.F.E + CARBON
10	ANILLO GUIA GUIDE RING	2	P.T.F.E + BRONCE P.T.F.E + BRONZE
11	JUNTA TÓRICA ÉMBOLO PISTON O-RING	4	N.B.R. N.B.R.
12	JUNTA TÓRICA EJE SHAFT O-RING	2	N.B.R. N.B.R.
13	JUNTA TÓRICA EJE SHAFT O-RING	2	N.B.R. N.B.R.
14	MUELLES PRECARGADOS PRELOADED SPRINGS	12	DIN-17223-C (2) (4) DIN-17223-C (2) (4)
15	LEVA CAM	1	ACERO (2) STEEL (2)
16	EJE SHAFT	1	ACERO (2) STEEL (2)
17	JUNTA TÓRICA PLACA PLATE O-RING	2	N.B.R. N.B.R.
18	JUNTA TÓRICA TAPA CAP O-RING	2	N.B.R. N.B.R.
19	PLACA CONEXIÓN NEUMÁTICA PNEUMATIC CONNECTION PLATE	1	ACERO INOXIDABLE CF8M CF8M STAINLESS STEEL
20	TORNILLO ALLEN PLACA PLATE ALLEN SCREW	2	ACERO INOXIDABLE AISI-304 AISI-304 STAINLESS STEEL
21	TORNILLO HEXAGONAL HEXAGONAL SCREW	2	ACERO INOXIDABLE AISI-304 AISI-304 STAINLESS STEEL
22	TUERCA NUT	2	ACERO INOXIDABLE AISI-304 AISI-304 STAINLESS STEEL
23	ARANDELA BUSHING	2	ACERO INOXIDABLE AISI-303 AISI-303 STAINLESS STEEL
24	JUNTA TÓRICA O-RING	2	N.B.R. N.B.R.
25	PIÑÓN GEAR	1	ALEACION DE ALUMINIO (5) ALUMINIUM ALLOY (5)
26	ARANDELA WASHER	12	ACERO INOXIDABLE AISI-304 AISI-304 STAINLESS STEEL
27	ARGOLLA HOP	2	ACERO INOXIDABLE AISI-304 AISI-304 STAINLESS STEEL
28	CASQUILLO CAP	1	POLIACETAL POLYCETAL

- (1) RECUBRIMIENTO CON POLIAMIDA.  
COVERED WITH POLYAMIDE.
- (2) RECUBRIMIENTO POR CATAFORESIS.  
COVERED BY CATAPHORESIS.
- (4) CANTIDAD VARIABLE, CONSULTAR  
TABLAS PARES SIMPLE EFECTO.  
VARIABLE QUANTITY, PLEASE SEE THE  
SPRING RETURN TORQUE CHART.
- (5) BRUÑIDO CON BOLAS.  
BALL BURNISHING.

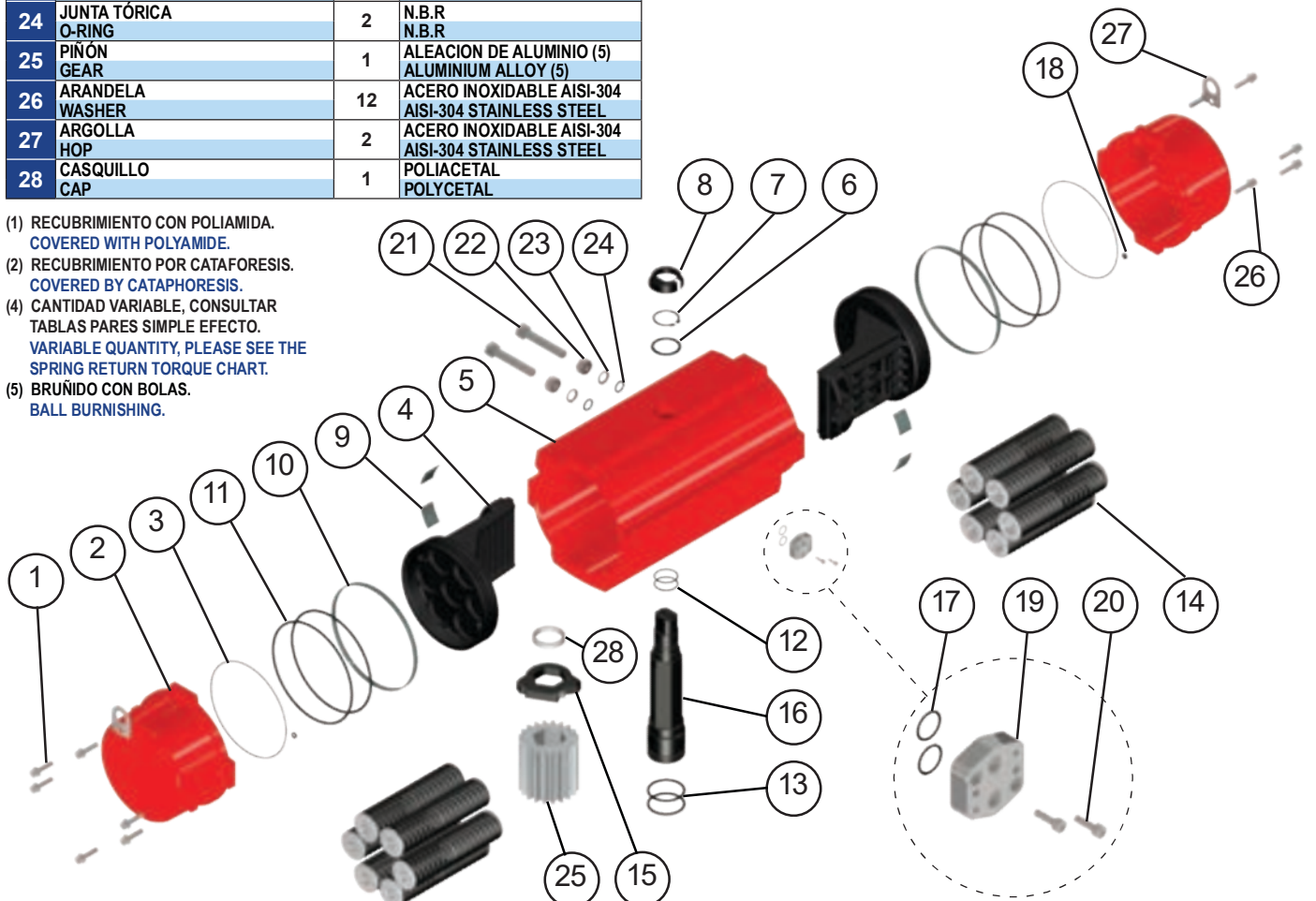

ACTUADOR NEUMÁTICO DE ALUMINIO  
ALUMINIUM PNEUMATIC ACTUATOR

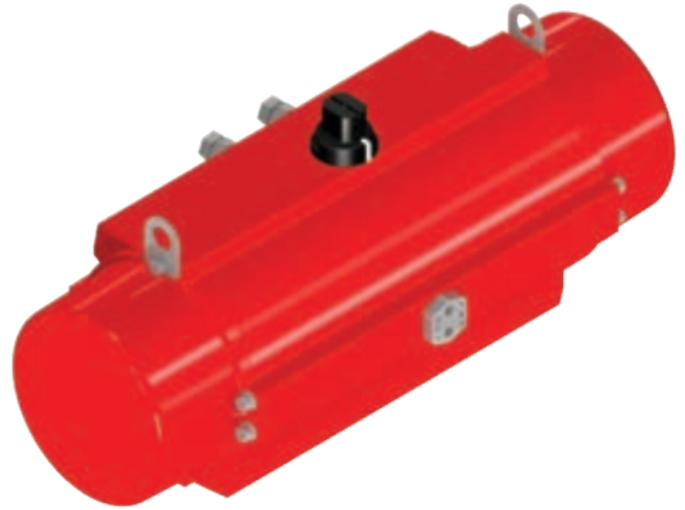

PA50: Doble Efecto / Double Acting

PA50S: Simple Efecto / Spring Return

MODELOS MODELS	TIEMPO DE MANIOBRA EN SEG. CYCLE TIME IN SECS.		PESOS WEIGHTS		CAPACIDAD EN LITROS CAPACITY IN LITRES	
	PARA ABRIR TO OPEN	PARA CERRAR TO CLOSE	Kg.	Lb.	PARA ABRIR TO OPEN	PARA CERRAR TO CLOSE
PA50	3	2,5	35	77,2	10,5	14,1
PA50S	3,7	2,9	53	116,9	10,5	

Tiempo de maniobra sin par resistente a 6 bar.  
Cycle time w/o resistant torque at 6 bar.

Dimensiones en mm.  
Dimensions in mm.

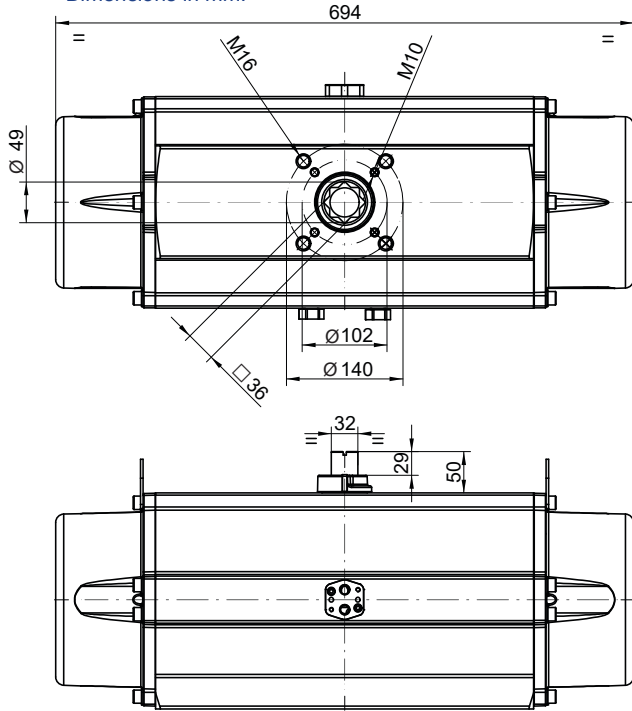

Para calcular el consumo, multiplicar las cifras del cuadro por la presión real de trabajo.

To calculate the consumption, multiply the above figures by the real working pressure.

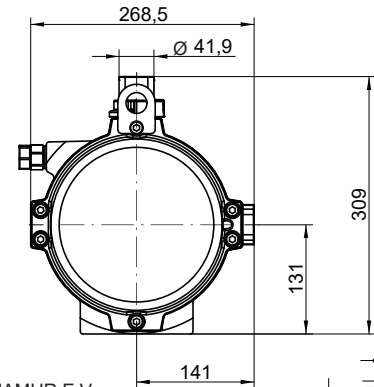
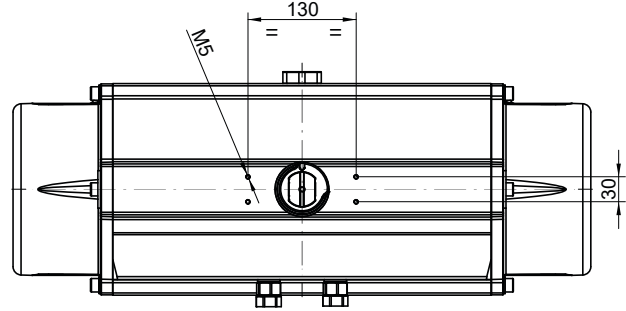

NORMA NAMUR E.V  
SOLENOID NAMUR NORM

1/4"BSPP (4)  
CERRAR  
CLOSE

1/4"BSPP (2)  
ABRIR  
OPEN

OPTION: 1/4" NPT

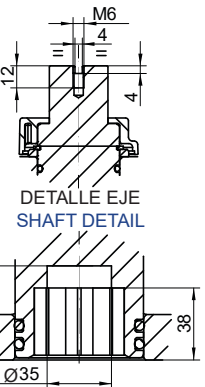

### PARES DOBLE EFECTO DOUBLE ACTING TORQUES

PA50	PRESION AIRE AIR PRESSURE							
bar	3	4	4,5	5	5,5	6	7	8
p.s.i	43,5	58	65,3	72,5	79,8	87	101,5	116
Nm	998	1.354	1.532	1.711	1.889	2.067	2.424	2.780
Lb.in	8.833	11.987	13.564	15.142	16.721	18.296	21.451	24.605

### PARES SIMPLE EFECTO SPRING RETURN TORQUES

PA50S	PAR MUELLES SPRING TORQUES		PAR A LA PRESIÓN INDICADA AIR TORQUE AT INDICATED PRESSURE																
			3		4		4,5		5		5,5		6		7		8		bar
N	INICIAL INITIAL	FINAL END	INICIAL INITIAL	FINAL END	INICIAL INITIAL	FINAL END	INICIAL INITIAL	FINAL END	INICIAL INITIAL	FINAL END	INICIAL INITIAL	FINAL END	INICIAL INITIAL	FINAL END	INICIAL INITIAL	FINAL END	INICIAL INITIAL	FINAL END	p.s.i
7**	1.663 14.718	956,1 8.462									932,9 8.256	226 2.000	1.111 9.831	404 3.575	1.468 12.990	761 6.734	1.824 16.141	1.117 9.885	Nm Lb.in
6*	1.425 12.614	819,5 7.253					712,5 6.306	107 944,3	891,5 7.890	286 2.528	1.070 9.465	464 4.104	1.248 11.040	642 5.679	1.605 14.200	999 8.838	1.961 17.350	1.355 11.989	Nm Lb.in
5	1.187 10.511	682,9 6.044			671,1 5.939	167 1.472	849,1 7.515	345 3.047	1.028 9.099	524 4.631	1.206 10.674	702 6.207	1.384 12.249	880 7.782	1.741 15.409	1.237 10.941	2.097 18.559	1.593 14.092	Nm Lb.in
4	989,7 8.759	569,1 5.037			784,9 6.946	364,3 3.224	962,9 8.522	542,3 4.799	1.142 10.106	721,3 6.384	1.320 11.681	899,3 7.959	1.498 13.256	1.077 9.534	1.855 16.416	1.434 12.694	2.211 19.566	1.790 15.844	Nm Lb.in
3	824,8 7.299	474,2 4.197	523,8 4.636	173,2 1.533	879,8 7.786	529,2 4.683	1.058 9.362	707,2 6.259	1.237 10.946	886,2 7.843	1.415 12.521	1.064 9.418	1.593 14.096	1.242 10.993	1.950 17.256	1.599 14.153	2.306 20.406	1.955 17.304	Nm Lb.in
2	687,3 6.083	395,2 3.498	602,8 5.335	310,7 2.750	958,8 8.485	666,7 5.900	1.137 10.061	844,7 7.476	1.316 11.645	1.024 9.060	1.494 13.220	1.202 10.635	1.672 14.795	1.380 12.210	2.029 17.955	1.737 15.370	2.385 21.105	2.093 18.520	Nm Lb.in

N: Número de muelles por banda  
Number of springs per side

\* Número de muelles estándar  
\* Standard number of springs

\*\* Opcional (bajo pedido)  
\*\* Optional (on request)