

DESPIECE

DISASSEMBLY



ACTUADOR NEUMÁTICO DE ALUMINIO
ALUMINIUM PNEUMATIC ACTUATOR



PA20: Doble Efecto / Double Acting

PA20S: Simple Efecto / Spring Return

Nº	Descripción Description	Cant. Quant.	Material Material
1	TORNILLO ALLEN TAPA CAP ALLEN SCREW	8	ACERO INOXIDABLE AISI-304 AISI-304 STAINLESS STEEL
2	TAPA CAP	2	ALEACIÓN ALUMINIO (2) + (7) ALUMINIUM ALLOY (2) + (7)
3	JUNTA TÓRICA TAPA CAP-O-RING	2	N.B.R. N.B.R.
4	ÉMBOLO PISTON	2	ALEACIÓN ALUMINIO (2) ALUMINIUM ALLOY (2)
5	CILINDRO CYLINDER	1	ALEACIÓN DE ALUMINIO (2) + (1) ALUMINIUM ALLOY (2) + (1)
6	ARANDELA WASHER	1	POLIACETAL POLYACETAL
7	ANILLO DE SEGURIDAD SPRING CLIP	1	ACERO (3) STEEL (3)
8	INDICADOR VISUAL POSITION INDICATOR	1	POLIAMIDA POLYAMIDE
9	GUIA ÉMBOLO PISTON GUIDE	2	POLIACETAL + Mb POLYACETAL + Mb
10	ANILLO GUIA GUIDE RING	2	POLIACETAL + Mb POLYACETAL + Mb
11	JUNTA TÓRICA ÉMBOLO PISTON O-RING	2	N.B.R. N.B.R.
12	JUNTA TÓRICA EJE SHAFT O-RING	2	N.B.R. N.B.R.
13	JUNTA TÓRICA EJE SHAFT O-RING	2	N.B.R. N.B.R.
14	MUELLES PRECARGADOS PRELOADED SPRINGS	12	DIN-17223-C (6) (4) DIN-17223-C (6) (4)
15	LEVA CAM	1	ACERO (2) STEEL (2)
16	EJE SHAFT	1	ACERO (2) STEEL (2)
17	JUNTA TÓRICA PLACA PLATE O-RING	2	N.B.R. N.B.R.
18	TUERCA NUT	4	ACERO INOXIDABLE AISI-304 AISI-304 STAINLESS STEEL
19	PLACA CONEXIÓN NEUMÁTICA PNEUMATIC CONNECTION PLATE	1	POLIAMIDA + FV POLYAMIDE + FG
20	TORNILLO ALLEN PLACA PLATE ALLEN SCREW	2	ACERO INOXIDABLE AISI-304 AISI-304 STAINLESS STEEL
21	TORNILLO HEXAGONAL HEXAGONAL SCREW	2	ACERO INOXIDABLE AISI-304 AISI-304 STAINLESS STEEL
22	TUERCA NUT	2	ACERO INOXIDABLE AISI-304 AISI-304 STAINLESS STEEL
23	ARANDELA BUSHING	2	ACERO INOXIDABLE AISI-316 AISI-316 STAINLESS STEEL
24	JUNTA TÓRICA O-RING	2	N.B.R. N.B.R.
25	PIÑÓN GEAR	1	ALEACIÓN ALUMINIO (5) ALUMINIUM ALLOY (5)
26	ARANDELA TAPA CAP WASHER	8	ACERO INOXIDABLE AISI-304 AISI-304 STAINLESS STEEL

- (1) RECUBRIMIENTO CON POLIAMIDA.
COVERED WITH POLYAMIDE.
- (2) RECUBRIMIENTO POR CATAFORESIS.
COVERED BY CATHORESIS.
- (3) RECUBIERTO CON NÍQUEL-TEFLON.
COVERED BY NIKEL-P.T.F.E.
- (4) CANTIDAD VARIABLE, CONSULTAR
TABLAS PARES SIMPLE EFECTO.
VARIABLE QUANTITY, PLEASE SEE THE
SPRING RETURN TORQUE CHART.
- (5) BRUÑIDO CON BOLAS.
BALL BURNISHING.
- (6) PASIVADO DE CROMO TRIVALENTE.
TRIVALENT CHROMINIUM PASSIVATION.
- (7) RECUBRIMIENTO CON POLIURETANO.
COVERED WITH POLYURETHANE.

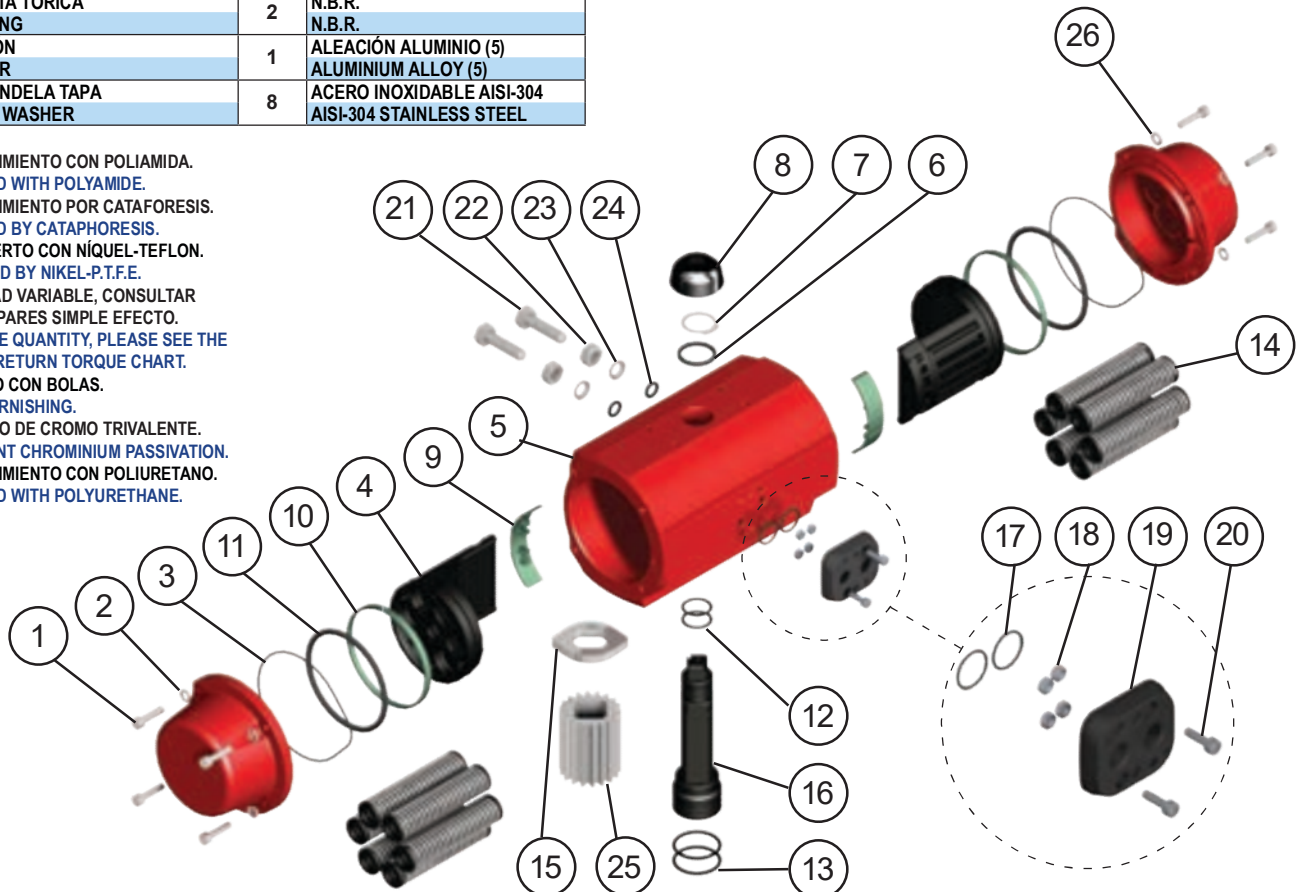

MODELOS MODELS	TIEMPO DE MANIOBRA EN SEG. CYCLE TIME IN SECS.		PESOS WEIGHTS		CAPACIDAD EN LITROS CAPACITY IN LITRES	
	PARA ABRIR TO OPEN	PARA CERRAR TO CLOSE	Kg.	Lb.	PARA ABRIR TO OPEN	PARA CERRAR TO CLOSE
PA20	0,4	0,4	5,61	12,36	0,8	1,15
PA20S	0,5	0,5	6,63	14,61	0,8	

Tiempo de maniobra sin par resistente a 6 bar.
Cycle time w/o resistant torque at 6 bar.

Dimensiones en mm.
Dimensions in mm.

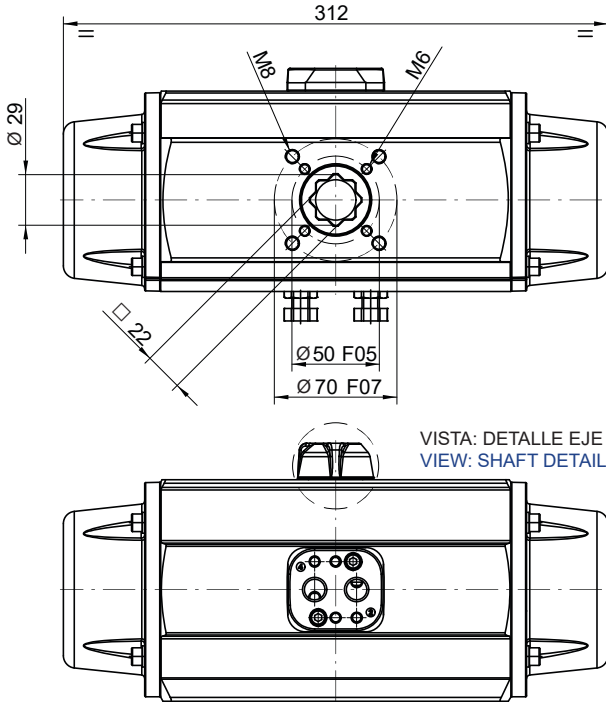

Para calcular el consumo, multiplicar las cifras del cuadro por la presión real de trabajo.

To calculate the consumption, multiply the above figures by the real working pressure.

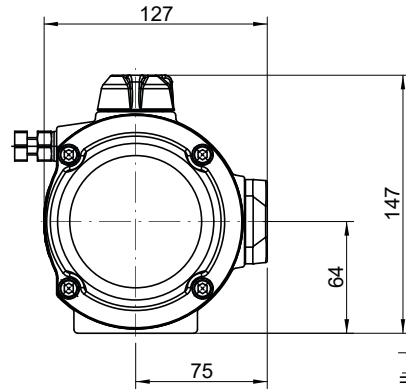
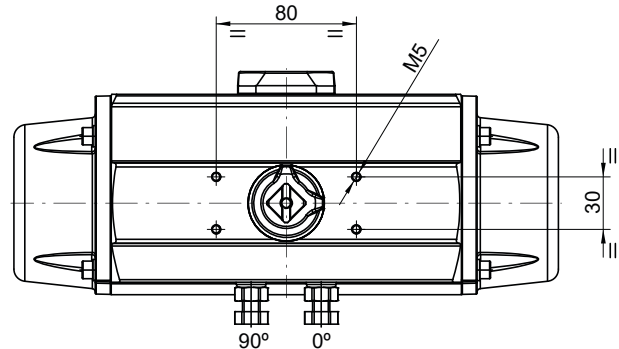

PARES DOBLE EFECTO DOUBLE ACTING TORQUES

PA20	PRESION AIRE AIR PRESSURE							
bar	3	4	4,5	5	5,5	6	7	8
p.s.i	43,5	58	65,3	72,5	79,8	87	101,5	116
Nm	77,7	107	121,7	136,3	151	165,5	194,8	224
Lb.in	688	947	1.076	1.206	1.336	1.465	1.724	1.983

PARES SIMPLE EFECTO SPRING RETURN TORQUES

PA20S	PAR MUELLES SPRING TORQUES		PAR A LA PRESIÓN INDICADA AIR TORQUE AT INDICATED PRESSURE																		
			3		4		4,5		5		5,5		6		7		8		bar		
N	INICIAL INITIAL	FINAL END	43,5		58		65,3		72,5		79,8		87		101,5		116		p.s.i		
6*	104,7	65,8							55,9	17	70,5	31,6	85,2	46,3	99,7	60,8	129	90,1	158,2	119,3	Nm
	926,7	582,4							494,1	149,8	624	279,7	754,1	409,8	882,4	538,1	1.142	797	1.400	1.056	Lb.in
5	87,2	54,8			52,2	19,8	66,9	34,5	81,5	49,1	96,2	63,8	110,7	78,3	140	107,6	169,2	136,8			Nm
	771,8	485			462	175	591,5	304,7	721,3	434,6	851,4	564,7	980	693	1.239	952,3	1.497	1.211			Lb.in
4	69,8	43,9	33,8	8	63,1	37,2	77,8	51,9	92,4	66,5	107,1	81,2	121,6	95,7	150,9	125	180,1	154,2			Nm
	617,8	388,5	299,2	69,9	558,5	329,2	688	458,7	817,8	588,6	947,9	718,7	1.076	847	1.336	1.106	1.594	1.365			Lb.in
3	52,3	32,9	44,8	25,4	74,1	54,7	88,8	69,4	103,4	84	118,1	98,7	132,6	113,2	161,9	142,5					Nm
	462,9	291,2	396,5	224,8	655,8	484,1	785,3	613,6	915,2	743,5	1045	873,6	1.174	1.002	1.433	1.261					Lb.in
2	34,9	21,9	55,8	42,8	85,1	72,1	99,8	86,8	114,4	101,4	129,1	116,1	143,6	130,6							Nm
	308,9	193,8	493,9	378,8	753,2	638,1	882,7	767,6	1.012	897,5	1.143	1.027	1.271	1.156							Lb.in

N: Número de muelles por banda
Number of springs per side

* Número de muelles estándar
* Standard number of springs

