

DESPIECE

DISASSEMBLY



Nº	Descripción Description	Cant. Quant.	Material Material
1	TORNILLO AVELLANADO TAPA CAP COUNTERSUNK SCREW	8	ACERO INOXIDABLE AISI-304 AISI-304 STAINLESS STEEL
2	TAPA CAP	2	ALEACIÓN ALUMINIO (2) + (7) ALUMINIUM ALLOY (2) + (7)
3	JUNTA TÓRICA TAPA CAP-O-RING	2	N.B.R. N.B.R.
4	ÉMBOLO PISTON	2	ALEACIÓN ALUMINIO (2) ALUMINIUM ALLOY (2)
5	CILINDRO CYLINDER	1	ALEACIÓN DE ALUMINIO (2) + (1) ALUMINIUM ALLOY (2) + (1)
6	ARANDELA WASHER	1	POLIACETAL POLYACETAL
7	ANILLO DE SEGURIDAD SPRING CLIP	1	ACERO INOXIDABLE STAINLESS STEEL
8	INDICADOR VISUAL POSITION INDICATOR	1	POLIAMIDA POLYAMIDE
9	GUIA ÉMBOLO PISTON GUIDE	2	POLIACETAL + Mb POLYACETAL + Mb
10	ANILLO GUIA GUIDE RING	2	POLIACETAL + Mb POLYACETAL + Mb
11	JUNTA TÓRICA ÉMBOLO PISTON O-RING	2	N.B.R. N.B.R.
12	JUNTA TÓRICA EJE SHAFT O-RING	2	N.B.R. N.B.R.
13	JUNTA TÓRICA EJE SHAFT O-RING	2	N.B.R. N.B.R.
14	MUELLES PRECARGADOS PRELOADED SPRINGS	12	DIN-17223-C (6) (4) DIN-17223-C (6) (4)
15	LEVA CAM	1	ACERO (2) STEEL (2)
16	EJE SHAFT	1	ACERO (2) STEEL (2)
17	JUNTA TÓRICA PLACA PLATE O-RING	2	N.B.R. N.B.R.
18	TUERCA NUT	4	ACERO INOXIDABLE AISI-304 AISI-304 STAINLESS STEEL
19	PLACA CONEXIÓN NEUMÁTICA PNEUMATIC CONNECTION PLATE	1	POLIAMIDA + FV POLYAMIDE + FG
20	TORNILLO ALLEN PLACA PLATE ALLEN SCREW	2	ACERO INOXIDABLE AISI-304 AISI-304 STAINLESS STEEL
21	TORNILLO HEXAGONAL HEXAGONAL SCREW	2	ACERO INOXIDABLE AISI-304 AISI-304 STAINLESS STEEL
22	TUERCA NUT	2	ACERO INOXIDABLE AISI-304 AISI-304 STAINLESS STEEL
23	ARANDELA BUSHING	2	ACERO INOXIDABLE AISI-316 AISI-316 STAINLESS STEEL
24	JUNTA TÓRICA O-RING	2	N.B.R. N.B.R.

- (1) RECUBRIMIENTO CON POLIAMIDA.
COVERED WITH POLYAMIDE.
- (2) RECUBRIMIENTO POR CATAFORESIS.
COVERED BY CATAPHORESIS.
- (4) CANTIDAD VARIABLE, CONSULTAR
TABLAS PARES SIMPLE EFECTO.
VARIABLE QUANTITY, PLEASE SEE THE
SPRING RETURN TORQUE CHART.
- (6) PASIVADO DE CROMO TRIVALENTE.
TRIVALENT CHROMINIUM PASSIVATION.
- (7) RECUBRIMIENTO CON POLIURETANO.
COVERED WITH POLYURETHANE.

ACTUADOR NEUMÁTICO DE ALUMINIO
ALUMINIUM PNEUMATIC ACTUATOR



PA05: Doble Efecto / Double Acting
PA05S: Simple Efecto / Spring Return

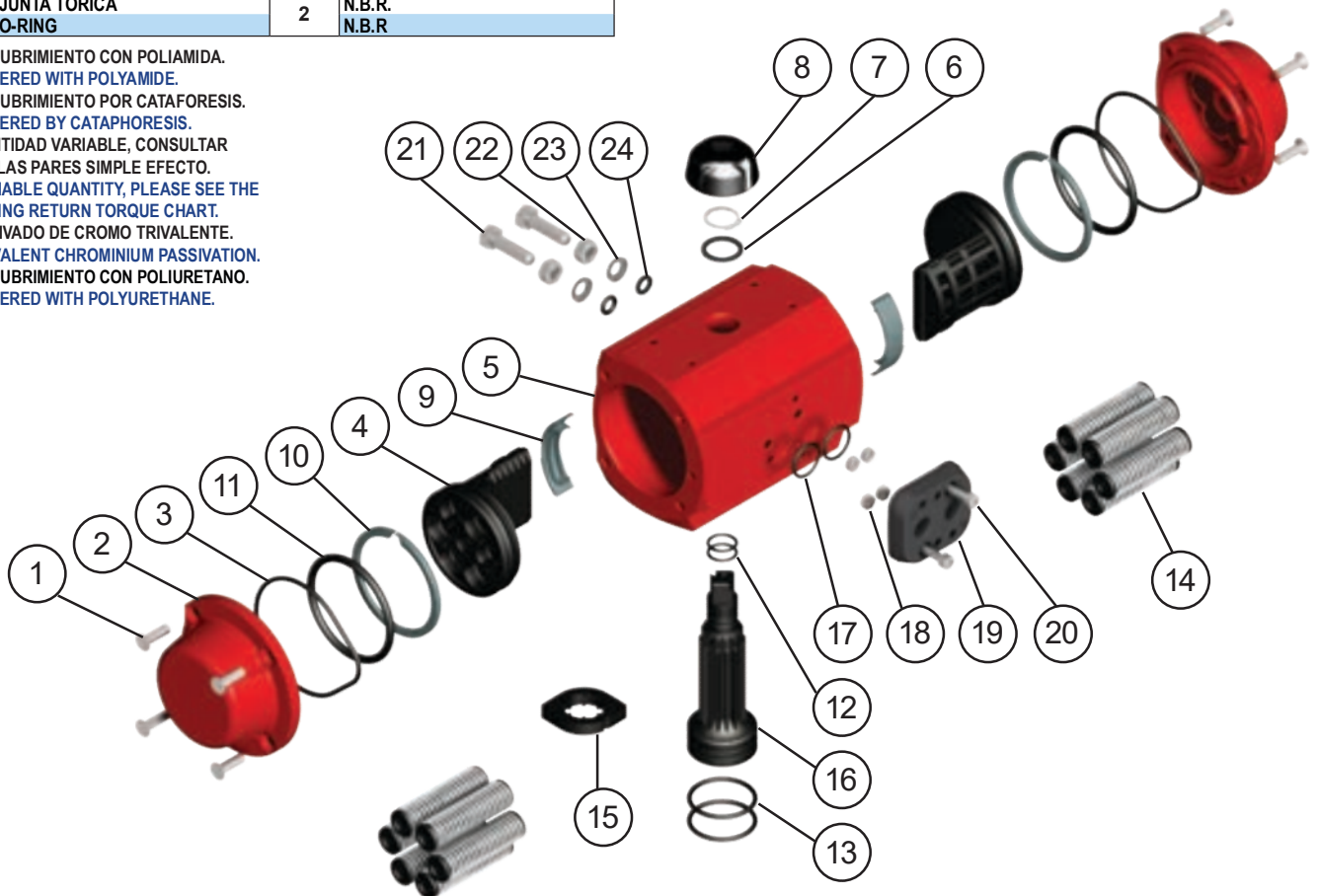

MODELOS MODELS	TIEMPO DE MANIOBRA EN SEG. CYCLE TIME IN SECS.		PESOS WEIGHTS		CAPACIDAD EN LITROS CAPACITY IN LITRES	
	PARA ABRIR TO OPEN	PARA CERRAR TO CLOSE	Kg.	Lb.	PARA ABRIR TO OPEN	PARA CERRAR TO CLOSE
PA05	0,2	0,2	2,57	5,67	0,28	0,37
PA05S	0,25	0,25	2,94	6,49	0,28	

Tiempo de maniobra sin par resistente a 6 bar.
Cycle time w/o resistant torque at 6 bar.

Dimensiones en mm.
Dimensions in mm.

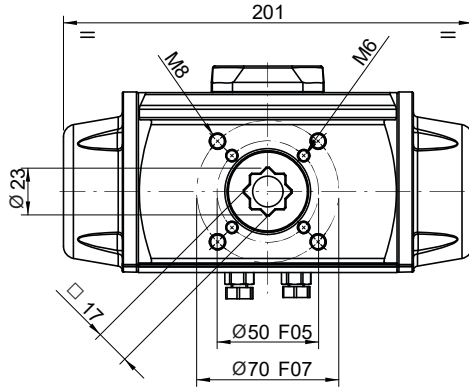

Para calcular el consumo, multiplicar las cifras del cuadro por la presión real de trabajo.

To calculate the consumption, multiply the above figures by the real working pressure.

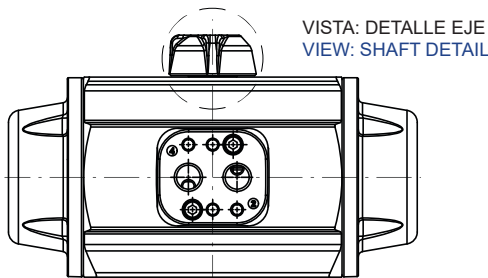
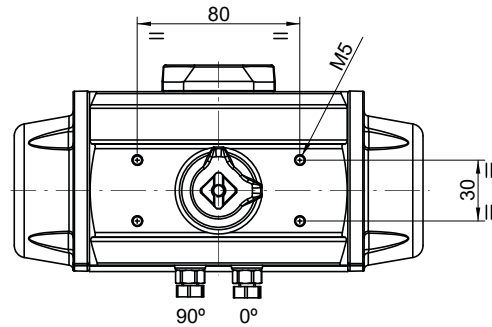

VISTA: DETALLE EJE
VIEW: SHAFT DETAIL

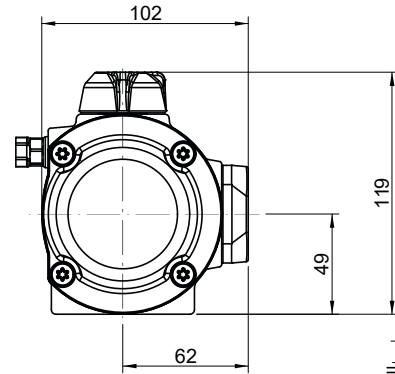

PARES DOBLE EFECTO DOUBLE ACTING TORQUES

PA05	PRESION AIRE AIR PRESSURE							
bar	3	4	4,5	5	5,5	6	7	8
p.s.i	43,5	58	65,3	72,5	79,8	87	101,5	116
Nm	23,5	32,3	36,7	41	45,3	49,7	58,4	67,1
Lb.in	208	286	324,5	363	401	440	517	594

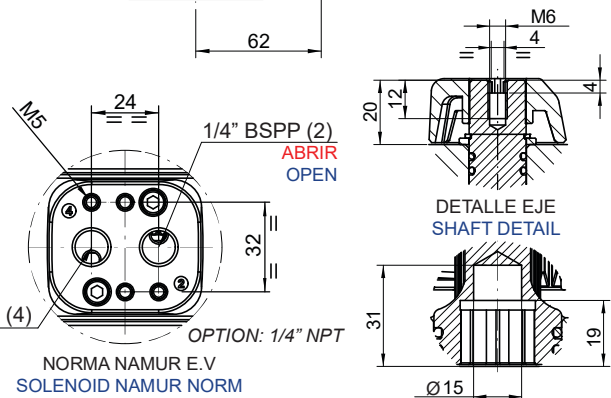

PARES SIMPLE EFECTO SPRING RETURN TORQUES

PA05S	PAR MUELLES SPRING TORQUES		PAR A LA PRESIÓN INDICADA AIR TORQUE AT INDICATED PRESSURE																		
			3		4		4,5		5		5,5		6		7		8		bar		
N	INICIAL INITIAL	FINAL END	43,5	58	65,3	72,5	79,8	87	101,5	116											
6*	31,4	20,9							15,8	5,3	20,1	9,6	24,4	13,9	28,8	18,3	37,5	27	46,2	35,7	Nm
	277,9	185							139,5	46,6	177,9	85	216	123	254,9	162	331,9	239	408,9	316	Lb.in
5	27	17,4			14,9	5,3	19,3	9,7	23,6	14	27,9	18,3	32,3	22,7	41	31,4	49,7	40,1			Nm
	239	154			131,9	46,9	170,5	85,5	208,9	123,9	246,9	162	285,9	200,9	362,9	277,5	439,9	354,9			Lb.in
4	21,8	13,9	9,6	1,7	18,4	10,5	22,8	14,9	27,1	19,2	31,4	23,5	35,8	27,9	44,5	36,6	53,2	45,3			Nm
	192,9	123	85	15	162,9	92,9	201,5	131,6	239,9	169,9	277,9	208	316,9	246,9	393,9	323,9	470,9	400,9			Lb.in
3	18,3	11,3	12,2	5,2	21	14	25,4	18,4	29,7	22,7	34	27	38,4	31,4	47,1	40,1					Nm
	162	100	108	46	185,9	123,9	224,5	162,5	262,9	200,9	300,9	239	339,9	277,9	416,9	354,9					Lb.in
2	12,2	7,8	15,7	11,3	24,5	20,1	28,9	24,5	33,2	28,8	37,5	33,1	41,9	37,5							Nm
	108	69	139	100	216,8	177,9	255,5	216,5	293,8	254,9	331,9	293	370,8	331,9							Lb.in

N: Número de muelles por banda y posición
Number of springs per side and position

* Número de muelles estándar
* Standard number of springs