

CMO Knife Gate Valve Series A – Unidirectional



HANDWHEEL with Rising Stem

OPTIONS

- Locking devices
- Extensions: stand, pipe, plates...
- ND higher than those give in the table

ACTUATOR INCLUDING

- Handwheel
- Stem
- Nut
- Stem protection hood

AVAILABLE

- Available: ND50 to ND 1200
- From ND600 the actuator is with gears.

*Other ND on request.

B = Max. width of the valve (without actuator)

P = Max. height of the valve (without actuator)

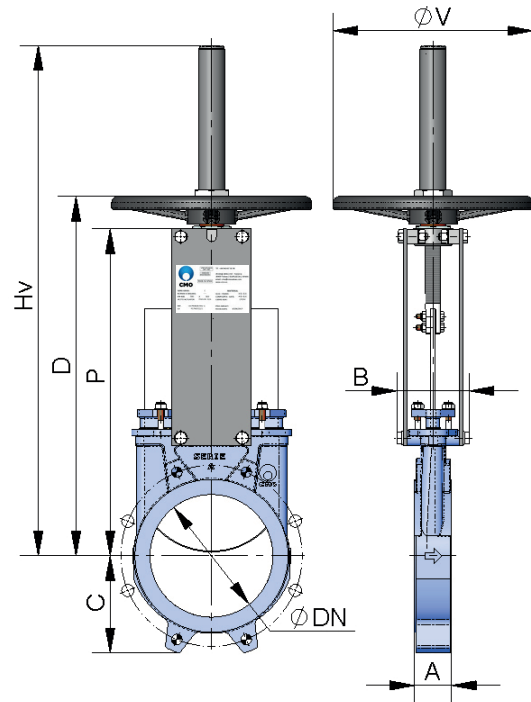

Fig. 17

ND	ΔP (kg/cm ²)	A	B	C	P	Hv	D	ØV	WEIGHT (kg.)
50	10	40	92	63	241	409	280	225	7
65	10	40	92	70	268	436	307	225	8
80	10	50	92	92	294	469	333	225	9
100	10	50	92	105	334	502	373	225	11
125	10	50	102	120	367	585	406	225	13
150	10	60	102	130	419	644	458	225	17
200	8	60	119	160	525	815	578	325	28
250	6	70	119	198	626	1016	679	325	40
300	6	70	119	234	726	1116	779	380	56
350	5	96	290	256	797	1336	906	450	94
400	5	100	290	292	903	1442	1012	450	116
450	3	106	290	308	989	1628	1098	450	162
500	3	110	290	340	1101	1738	1210	450	191
600	3	110	290	400	1307	2046	1416	450	264
700	2	110	320	453	1506	--	--	--	441
800	2	110	320	503	1720	--	--	--	568
900	2	110	320	583	1953	--	--	--	736
1000	2	110	320	613	2137	--	--	--	921
1200	2	150	340	728	2616	--	--	--	1350

Table 5