

THE GENERAL INSTRUCTIONS DURING PURCHASING OF MILK CREAM SEPARATOR

Check the complete set of supply of milk cream separator (further – separator) in concordance with CHAPTER 2 of the given manual.

Demand during purchasing the check of separator idle run.

ATTENTION!: You must carefully study the given maintenance manual  and pay special attention to safety precautions before use this centrifugal milk separator.

1. PURPOSE AND TECHNICAL FEATURES

Centrifugal milk separator “Motor Sich SCM-80-24” with electric drive efficiency not less, than 80 l/hours is intended for separation of the whole milk on cream and skim milk with simultaneous cleansing. During separator production the remanufacturing operations are performed. Therefore, the construction of particular parts can differ from registration certificate. These differences improve performance quality and maintenance of separator.

1.1 Milk productivity, l/hours, not less	90
1.2 Rotating frequency of bowl, rpm	10500±1000
1.3 Quantity of bowl disks, pcs.	10...12
1.4 Volume of milk collector, l	12
1.5 Fat content in skim milk, % not more than	0.05
1.6 Regulation of volumetric ratio of fat and skim milk	from 1:4 to 1:10
1.7 Power consumption, Wt not more than	60
1.8 Supply voltage, V	115±10%
1.9 Frequency of supply voltage, Hz	60
1.10 Temperature of milk, being separated, °C	35...40
1.11 Overall dimensions, mm, not more than dish diameter	365

height	520
1.12 Centrifugal milk separator mass, kg	6

2. SAFETY PRECAUTIONS

2.1 It is necessary to keep safety precautions in order to prevent fire possibility, electric injury and accidents during separator exploitation.

2.2 During its setting-up procedures it is necessary to carry out the next steps:

- check of completeness and security of details attachment;
- external examination (power cable and plug operability), case insulating details integrity;
- check of switch positive action;
- check of separator idle run.

ATTENTION! IT IS PROHIBITED TO OPERATE CENTRIFUGAL MILK SEPARATOR AT INITIATION OF AT LEAST ONE OF THE FOLLOWING FAULTS DURING THE OPERATION:

- damage of plug junction, power cable or its protective tube;
- inefficient switch operation;
- occurrence of smoke or smell, that are typical for the burn insulation;
- noise appearance;
- damage or crack occurrence in housing parts;
- unwanted sounds or raised vibration appearance. **Note.** It is allowed negligible jingling of the separator disks at the end of separation (i.e. operation without milk in the dish of milk collector).

2.3 It is necessary to use the separator properly.

It is prohibited to use it incorrectly, i.e. not for the operations it meant for.

2.4 It is disallowed to operate separator at loose nut of bowl (pos.6 (fig.2)).

2.5 It is prohibited to sectionalize separator until bowl full stop.

2.6 It is disallowed to:

- operate separator with defective electric wiring;

- pull plug out of the outlet by means of power cable;
- switch separator off (on) by means of pull out (plug in) (except of separator immediate halt at switch fault);
- stretch and overtwist power source cable and subject it to loads (for example to put the weight on it).

2.7 Before cleaning, it is necessary to switch separator off and pull power cable out of the outlet.

2.8 It is prohibited to open milk inlet plug earlier, than bowl reaches full rotational velocity (in 60...120 s after actuation);

2.9 It is disallowed to switch electric drive on, if cock plug is opened and milk continues passing to rotating bowl.

2.10 It is prohibited to operate separator at voltage drop less than 190 V. In the case of voltage drop less than admissible it is recommended to switch separator on via the consumer voltage stabilizer.

2.11 It is disallowed to wash separator with water jet. It is necessary to use soft fabric, wetted in cleaning solution in order to clean separator case.

2.12 Centrifugal milk separator maintenance has to be performed only in warranty repair shops and in service shops.

3. STRUCTURE AND PRINCIPLE OF OPERATION

3.1 Centrifugal milk separator (fig.1) consists of case 3 with electric motor 6, bowl 2, skim milk collector 21, cream collector 11, float 5, float bowl 4, milk collector 1, plug 10.

3.2 Switch 16 and reinforced cable are installed on case 3.

3.3 Electric motor 6 is mounted on case 3 by means of three pins and self-locking nuts 18. In order to decrease jerk during engine start and prevent bowl 2 descent from conical drive end, centrifugal milk separator is equipped with soft start device and absorbers – bushings 15 that are put in electric motor flange.

3.4 The bowl is movable operating element (fig.2). There under the action of centrifugal forces the process of milk separation on cream and skim milk occurs.

The bowl consists of disks holder 1 with set of aluminum disks 3, separating disk 4 with adjusting screw 7, cover 2, ring gasket 5, nut 6.

3.5 The device for reception and output (further – “disks”) serves for heat milk supply to the bowl and cream and skim milk output from the bowl.

Disks (fig.1) consist of milk collector with plug, float bowl, float, cream collector and skim milk collector.

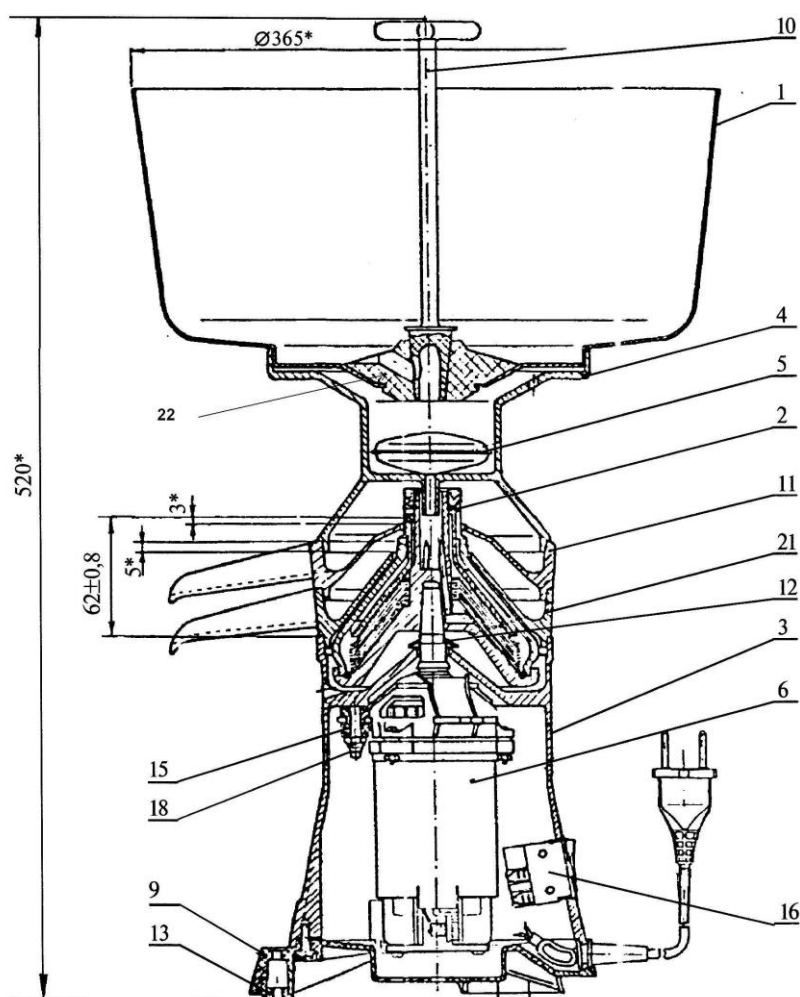

1 – milk collector, 2 – bowl, 3 – case, 4 – float bowl, 5 – float, 6 – electric motor, 9 – support, 10 – plug, 11 – cream collector, 12 – reflector, 13 - leg, 15 – bushing, 16 – switch, 18 – self-locking nut, 21 – skim milk collector, 22 – plug base.

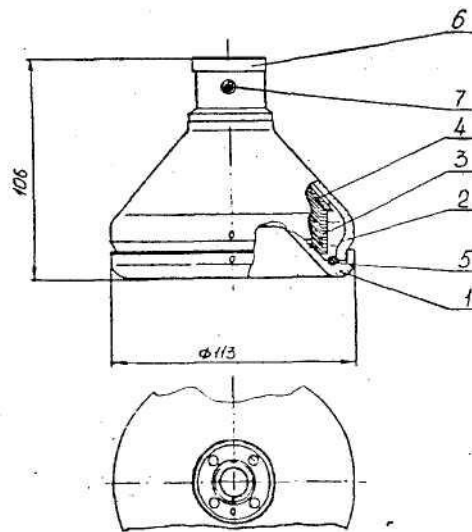
Figure 1

1 – disks holder, 2 – cover, 3 – disks of “A” and “B” type, 4 – separating disk, 5 – ring, 6 – nut, 7 – screw.

Figure 2

4. SETTING-UP PROCEDURES

4.1 The room where separator is placed has to be not dusty and dry with humidity of 65+15 %.

4.2 The installation surface has to be horizontal and smooth.

4.3 It is recommended to fasten the separator by means of three applicable screws with washers via the holes in support 9 (fig.1) to special applicable pedestal 22.

5. PLUG-IN

5.1 Before switching on it is necessary to follow the next procedure of assembly: put the bowl on conical drive end slightly holding it from the top (fig.1).

5.2 Install skim milk collector 21 and cream collector 11. Pay attention to correctness of their installations on case.

5.3 Turn over nut of the bowl and make sure that it does not touch the case and skim milk and cream collectors.

5.4 Nozzles of skim milk and cream collectors set in the correct position, place larger can for skim milk and less large for cream.

5.5 Install float bowl, put the float in cavity, install milk collector, insert plastic plug in conical hole of rubber case on milk collector bottom.

Attention! The plug in milk collector has to be in position “Closed”, i.e. sharp part of the plug handle has to be turned opposite from cavity on the edge of milk collector. Separator has to be switched only with the help of key switch.

5.6 Key switch has to be set in “0” position (i.e. turned off) before separator networking. After that put plug in the outlet.

Attention! It is prohibited to operate separator by farms without surge and short-circuit protectors.

***Note.** It is necessary to match cavity on float bowl and channel on cream collector during installation plastic float bowl.

6. MILK SEPARATION

6.1 Pour filtered whole milk in milk collector dish. Milk is separated better at once after milking or if it is heated till the temperature $(35...40)^{\circ}\text{C}$.

6.2 Turn on separator electric drive by means of switch. If rotational frequency of bowl reaches its maximal value in 60...120 s after actuation, open the cock, i.e. turn plug handle (its sharp part) to notch on the edge of milk collector.

6.3 Pour approximately 3 liters of warm water into the dish for milk in order to wash dish after separation and then leak it through the operated separator for remove the rest of skim milk and cream.

Attention! Before bowl removal make sure that separator switch is set into “0” position and plug is pulled out.

Bowl has to be removed from the electric drive shaft carefully. It is prohibited to sway bowl drastically on shaft, because it can lead to shaft deformation.

Note. It is allowed insignificant jingling of disks (without filling separator with milk), installed on case during validity check in the shop.

6.5 In order to stop the separator, turn the plug to the left or to the right of the milk collector, wait until cream and skim milk output stop and only after that disconnect electric drive by means of switch.

7. THE BOWL DISASSEMBLY PROCEDURE FOR WASHING

7.1 Bowl has to be disassembled by means of the special key (fig.3). Unscrew the nut. Usually bowl cover tightly fits on the disks holder, so bowl has to be turned over and it is necessary to hit wood board with thread segment end in the in the direction of the arrow.

It is prohibited to hit solid pedestal with thread segment end.

7.2 Opening the bowl, put separating disk off, after that put the set of disks and ribbon ring gasket off.

Note. Do not interrupt regulation of cream fat content during the bowl disassembly, i.e. do not unscrew adjusting screw in the upper part of the separating disk. Control the safety of ring gasket.

Attention! It is prohibited the bowl disassembly at nibbed adjusting screw 7 (fig.2).

7.3 Two disks types are installed in turn in the bowl: with mark "A" – 5...6 pcs. and with mark B – 5...6 pcs. Firstly the disk with mark "A" is installed on the disk holder and then disk with mark "B" etc.

Attention! It is recommended periodically (20-25 l or two fillings) to disassemble and wash the internal bowl details. At bowl assembly it is recommended to lubricate the nut with any edible fat. The periodicity depends on pollution of milk, being separated.

* Instead of the mark “A” in the low flange can be one center mark and instead of the mark “B” can be two center marks. In such a case firstly the disk with one center mark is installed on the disk holder and then disk with two center marks etc.

8. THE BOWL ASSEMBLY

8.1 The assembly is carried out in the reverse sequence to the disassembly, i.e. put the rubber ring into the cavity sequentially set the aluminum disks. During this procedure do not press on disks, because by means of slight rotation disk sits on triangle of the disk holder in need position. The set of disks has to be complete (the quantity is stated in the passport).

8.2 Cover the set of disks with separating disk in such a way, that its protuberance enters the gap of the bowl cover.

8.3 “0” mark on the bowl cover match with the same mark of the disk holder bottom (fig.2).

8.4 Tighten the screw by means of the hand. Perform the final nut tightening with special key. Execute the nut tightening till matching with “0” mark on the nut and scratch on the thread segment of the disk holder (fig.2), (fig.3).

Attention! Do not tighten the nut very strong and do not forget to perform tightening, otherwise the bowl depressurizes during operating turns.



Figure 3 – The bowl disassembly



Figure 4 – Cream fat content regulation

9. CREAM FAT CONTENT REGULATION

9.1 Regulate cream concentration by means of the screw with square hole, which is installed in the upper part of the separating disk. During regulation use square pin of the special key (fig.4).

9.2 In order to get concentrated cream, rotate the screw clockwise, in order to get not concentrated cream, rotate the screw counterclockwise. Usually it is sufficient to make one turn to one and another side for necessary regulation.

Attention! Rotate the screw carefully in order not to damage the thread in the separating disk. Thrust of the screw is not allowed the into the thread surface of bowl disk holder.

10. THE BOWL DETAILS SERVICING

10.1 It is necessary to wash the bowl details with warm water. Milk and dirt remains are removed by means of the scrub, all the channels are cleaned with brush, especially square hole of adjusting screw and also three oblique holes of the disk holder.

10.2 The bowl has to be washed after every separation. It is disallowed to apply acids and bases, because aluminum details will be covered with spots and can be destroyed.

10.3 The servicing of other separator details is the same as for the other bowl details. After washing it is necessary to wipe dry all the details with clean towel.

10.4 Pay special attention to the absence of the fat film on the driver cone and conical hole of the disk holder, because nonfulfilment of these requirements can lead to wear of the disk holder and driver cases.

11. COMPLETENESS

The separator consists of the following component parts:

Milk collector ready-assembled, pcs.	1
Bowl ready-assembled, pcs.	1
Case ready-assembled with electric drive, pcs.	1
Float bowl, pcs.	1
Float, pcs.	1
Cream collector, pcs.	1
Skim milk collector, pcs.	1
Plug, pcs.	1
Passport, pcs.	1
Pedestal, pcs.	1
Packing box, pcs.	1
Spare parts and accessories:	
a) rubber ring (for bowl sealing), pcs.	1
b) special key, pcs.	1
c) polyethylene casing, pcs.	1
d) separating disk, pcs.	1
e) bolt screw 4x40, pcs.	3

f) washer 04, pcs.

3

ELECTRICAL SCHEMATIC

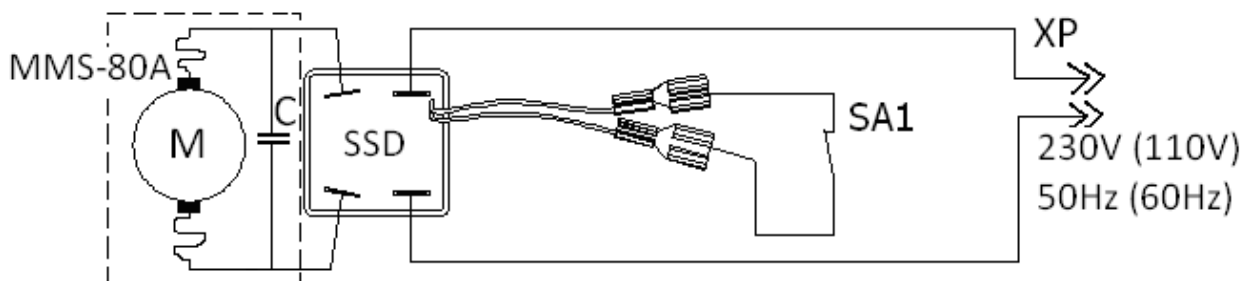

SA1 – switch BK59-19A20181-20YXJ4;

XP – reinforced cable ПBC-БП2x0,75-250-6-6 ГОСТ 28244-89;

M – electric motor ДМС-80А;

SSD – soft start device 100/240-2-120.

Figure 5

12. TEST CERTIFICATE

Separator “Motor Sich SCM-80-24” satisfy technical requirements TY Y 3.37-14307794-072-95 and is valid for exploitation.

Date of performance

Electric motor №

Inspector stamp

Packer

13. MANUFACTURER GUARANTEES

13.1 Manufacturer guarantees the separator normal operation during 12 months, passing from the date of sale by means of retail distribution network, or in case of its absence, normal operation is guaranteed during 12 months, passing from the date of performance.

13.2 If owner finds separator malfunction during the warranty period, he has a right to demand free maintenance or its replacement by manufacturing plant or by guarantee repair shop at the presence of guarantee coupons. The list of repair shops is in Appendix A.

Note. All repair works such as electric drives brushes replacement, its disassembly and assembly, cable replacement are conducted by specialists of household appliances repair shops.

13.3 Consumer has to show the factory-assembled separator for warranty repair.

Our address: 69000, Lenina Avenue 91/62, Zaporozhye, Ukraine

Telephone/fax: 00 380-61-278-11-23

Website: lk17.com