

# DIY Series

**Introducing** our very first D.I.Y. series - flatpack solid wood furniture. *Timber Actually* initiated this series with the intention to make solid wood furniture as accessible as possible for every household. Various parts can be mixed and matched to form different furniture pieces that are suited to the different needs of your dream home. It is also easy to assemble with basic tools and easy-to-follow instructions.

**The flatpack solid wood furniture** is designed to offer you a stable platform by using 100% sustainable source of solid wood material from Singapore local tree. The fabrication process of the furniture also adopts techniques that minimizes wastage, giving rise to a very affordable rate!

# NEO BENCH

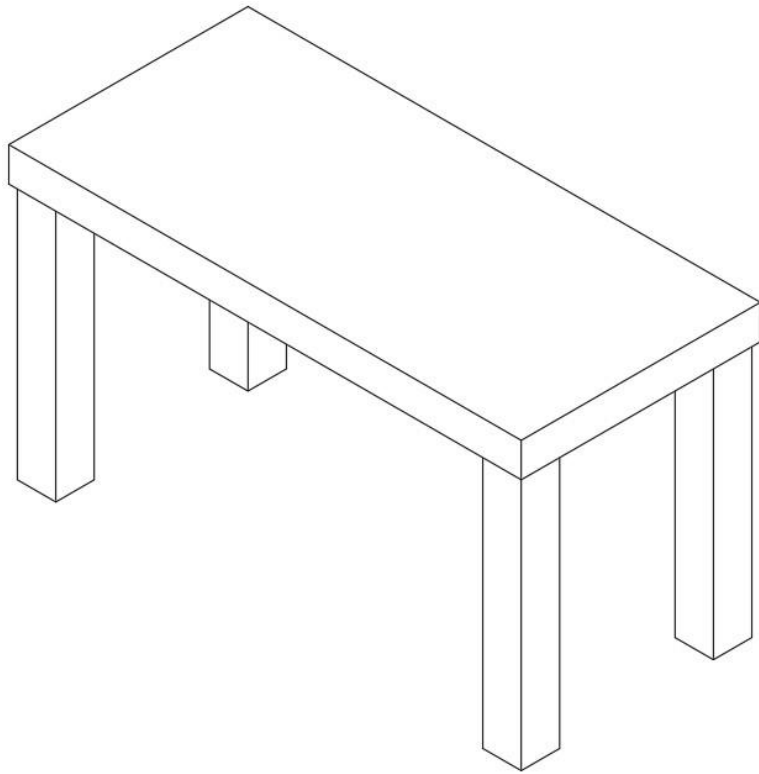

The Neo Bench is a sturdy and stylish spot for relaxation and reflection. It's sleek and streamlined design makes it versatile for any setting, ranging from homes to offices and even cafes. It not only provides comfort in any living space, but also adds a notch of prestige to any professional setting.

## Dimension:

Seat Top thickness: 40mm

Width & Length: 280mm x 400mm / 280mm x 600mm / 280mm x 900mm

Height: 240mm / 340mm / 440mm (including seat top)

## Assembly Options

**Pre-Assemble** - You will receive finished product, QC by us including glue applied, touch-up of any defects. No warranty for wear & tear.

**DIY/Self-Assemble** - You will receive material parts in loose including rubber pad which allowed you to assemble by yourself. Please purchase with a rubber mallet if you do not have one. No warranty for wear & tear during or after assembly.

Buy accessories here

[Link to Tools Website page](#)

Assembly Instructions

[Download link](#)

# Assembly Manual

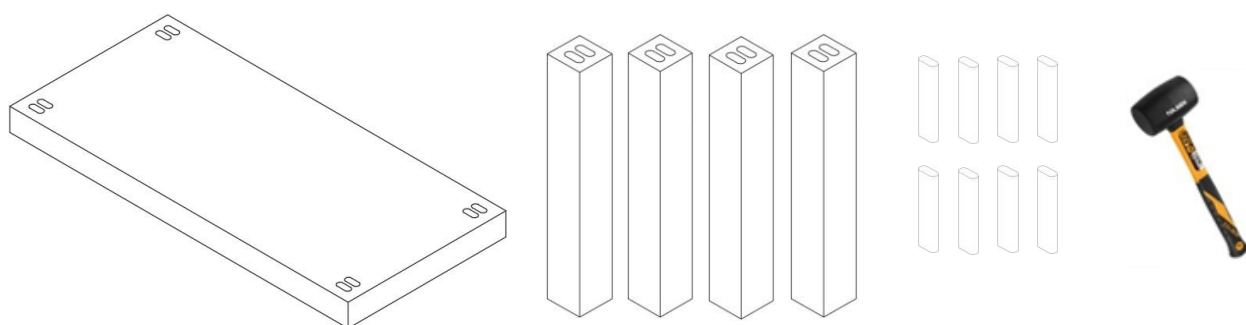

① Gather all parts & accessories needed.

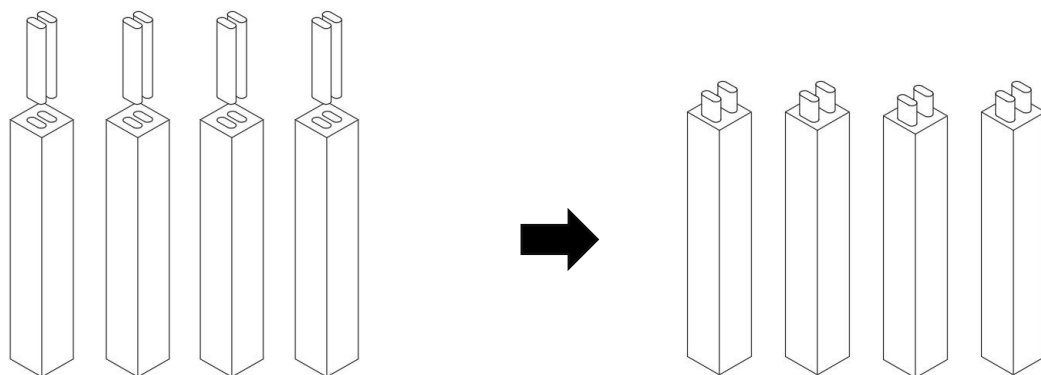

② Insert dominos into legs by using a mallet.  
(Safety Note: Beware of hitting your fingers)

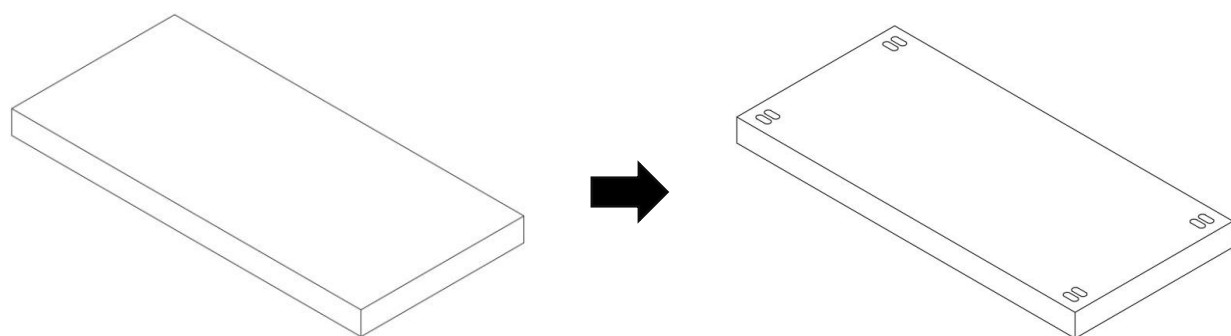

③ Place seat top upside down (domino holes facing upwards).

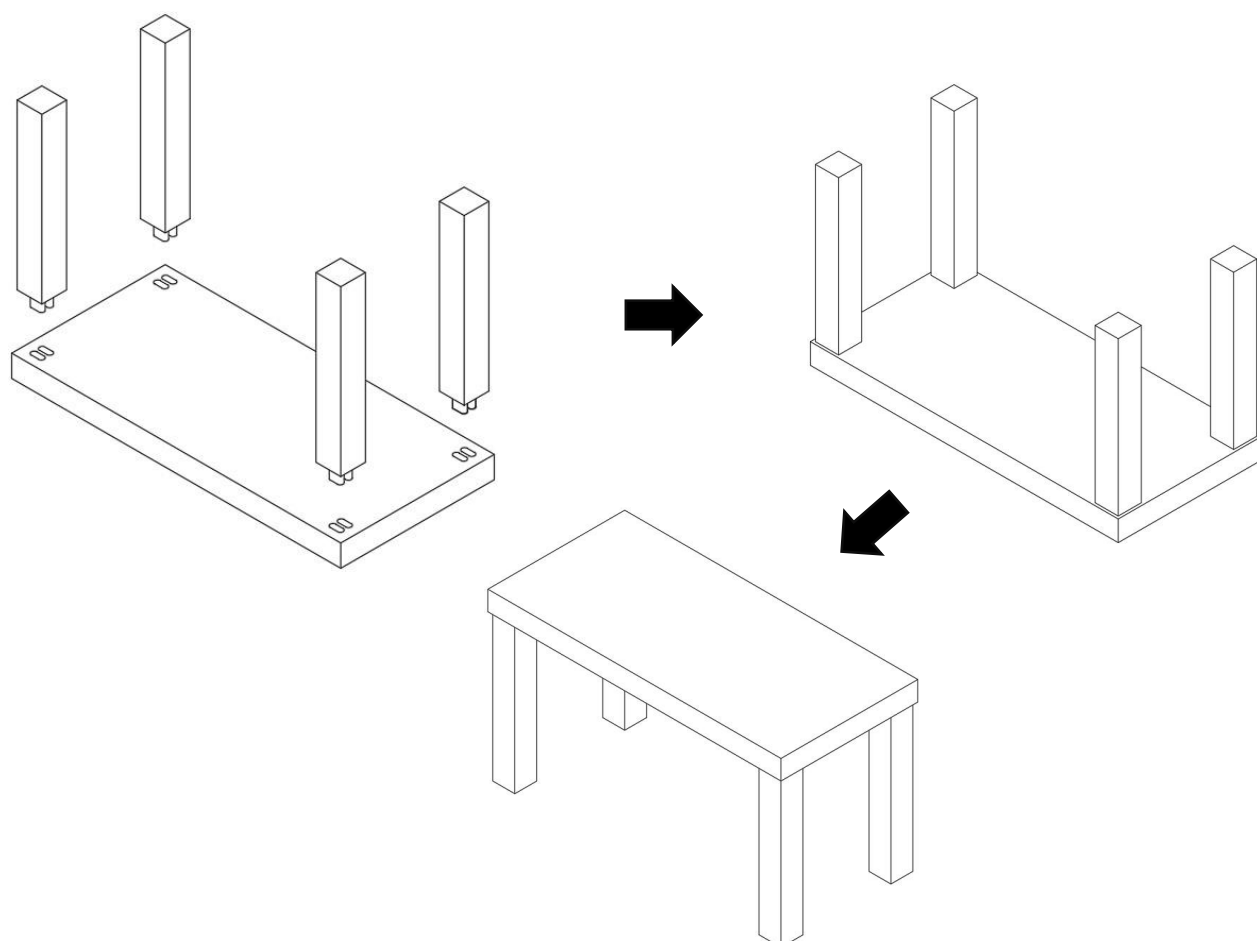

④ Join the legs with seat top and hammer with mallet till fit.  
Turn upside down, your self-assembly flat-pack stool showed up!

# ⚠ CAUTION



## **DO NOT STAND ON NEO BENCH**

Do not stand on the stool to avoid falling hazard. Stools are designed to provide support and stability when sitting, and standing on them can disrupt their intended function.



## **BEWARE OF HITTING FINGERS**

Be cautious, focus and avoid distractions while building your stool.



## **DO NOT ROCK OR SIT ON TWO LEGS**

Use in stable and balance manner. Incorrect way of sitting on bench can lead to instability and risk of the stool tipping over or even break the bench legs.