

# HÉRCULES 56"

**MASTERFAN**  
MOVIMIENTO DE AIRE

NOGAL BEAT Kingstrong



[www.nogalbeat.com](http://www.nogalbeat.com)

**40%** MÁS POTENCIA



**3 AÑOS DE GARANTIA**



DISPONIBLE EN PRESENTACIÓN TRI-PACK



**BLANCO | 3 ASPAS METAL**

COLOR DE ASPAS

BLANCO

<b>MAX 105 W</b> Consumo máximo	 127 V Voltaje	<b>105 W</b> Potencia de motor	 360 RPM	 25,000 m <sup>3</sup> /h Movimiento de aire
------------------------------------	----------------------	-----------------------------------	-------------	--

ANGULO DE ASPA

6°

OPERACION

CONTROL DE PARED

MOTOR

105W 5 VELOCIDADES 360 R/MIN

DIMENSIONES ABANICO [CM]

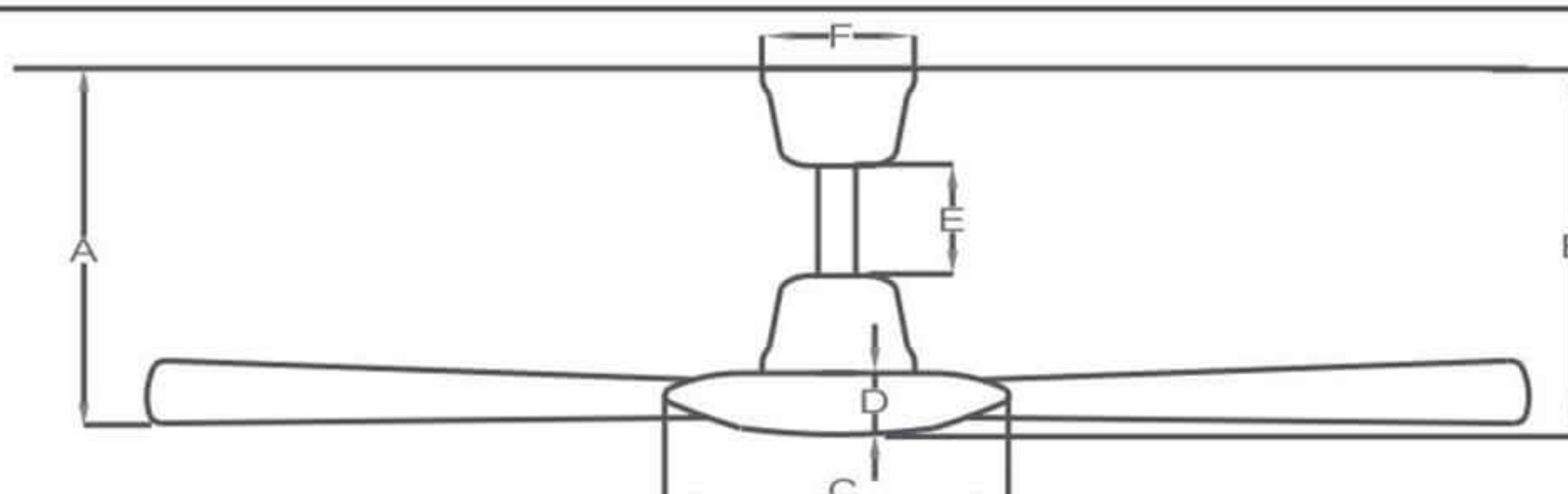

DIMENSIONES CAJA

65 x 28 x 21

MODO DE INSTALACION  
INCLUYE EXTENSION DE 12 PULGADAS



CONSUMO ENERGÉTICO

Total 105 W

**NOM**



A	B	C	D	E	F
47	50	24	9	20	10