



**Bicycles carrier**

Installation and usage instructions

EN

**Porte-vélos**

Instructions de montage et mode d'emploi

FR

**Portabicicletas**

Instrucciones de montaje y uso

ES



# CARRY-BIKE

**AIRSTREAM 75**

**02096-97A**



**AIRSTREAM**

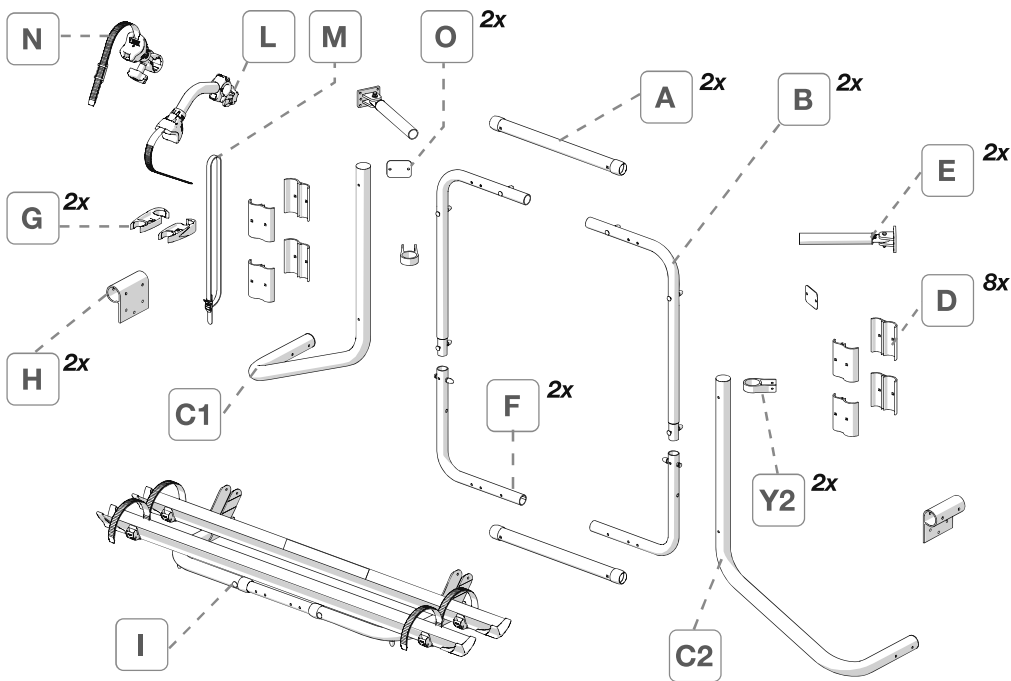

**P** 5,3x10x1  
2x

**Q** M5x50  
2x

**R** M5  
2x

**S** M5  
2x

**T** M6x50  
8x

**U** M6x65  
10x

**V** M6x60  
4x

**Z** 6,4x12,5x1,6  
22x

**W** M6  
24x

**X** M6  
24x

**K** 4x

**Y** M6x50  
2x



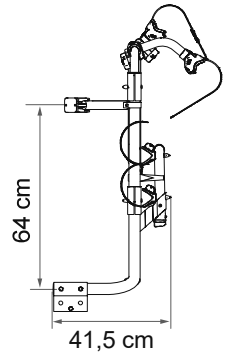
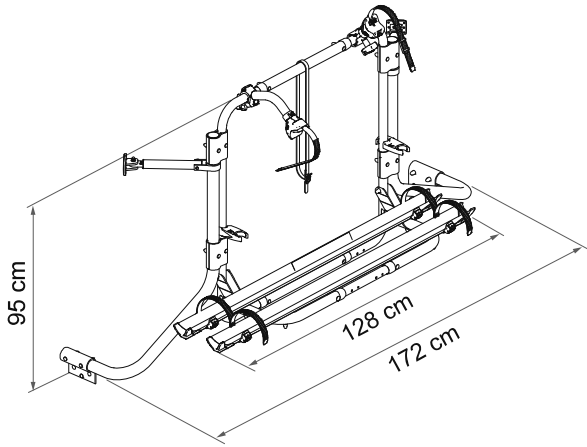

Package contents / Contenu de l'emballage / Contenido del embalaje	<b>p. 2</b>
Installation instructions / Instructions de montage / Instrucciones de montaje	<b>p. 4</b>
Instructions for use / Instructions d'installation / Instrucciones de uso	<b>p. 10</b>
Safety instructions / Consignes de sécurité / Instrucciones de seguridad	<b>p. 12</b>
Accessories / En option / Accesorios /	<b>p. 15</b>
Warranty / Garantie / Garantía	<b>p. 14</b>



**EN** Check that nothing has been damaged or deformed during transport. In the event of doubts or questions concerning the installation, use or limitations of the product, contact the dealer. **We recommend that the installation is carried out by qualified personnel and in compliance with current local regulations.**

**FR** Contrôler le contenu du colis et vérifier qu'aucune pièce n'ait été cassée ou déformée durant le transport. En cas de doutes ou de questions relatives à l'installation, l'utilisation du produit, contactez votre concessionnaire. **L'installation doit être réalisée par des personnes dûment qualifiées et conformément aux normes en vigueur dans le pays d'installation.**

**ES** Controlar que ningún detalle se haya roto o deformado durante el transporte. En caso de dudas o si tiene alguna pregunta sobre el montaje, uso y limitaciones del producto, póngase en contacto con el distribuidor. **Recomendamos que la instalación se realice por personal cualificado en conformidad con las regulaciones locales.**

1

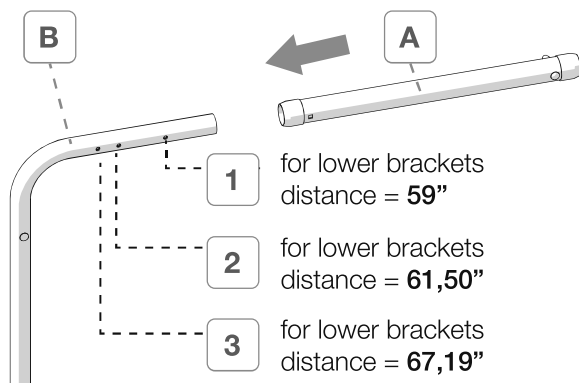
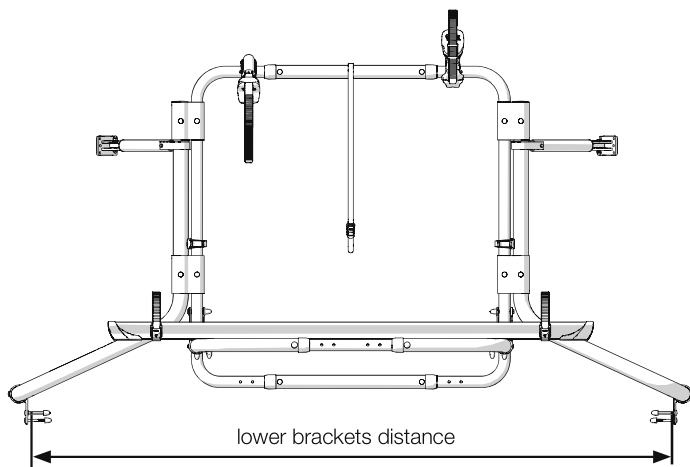

2

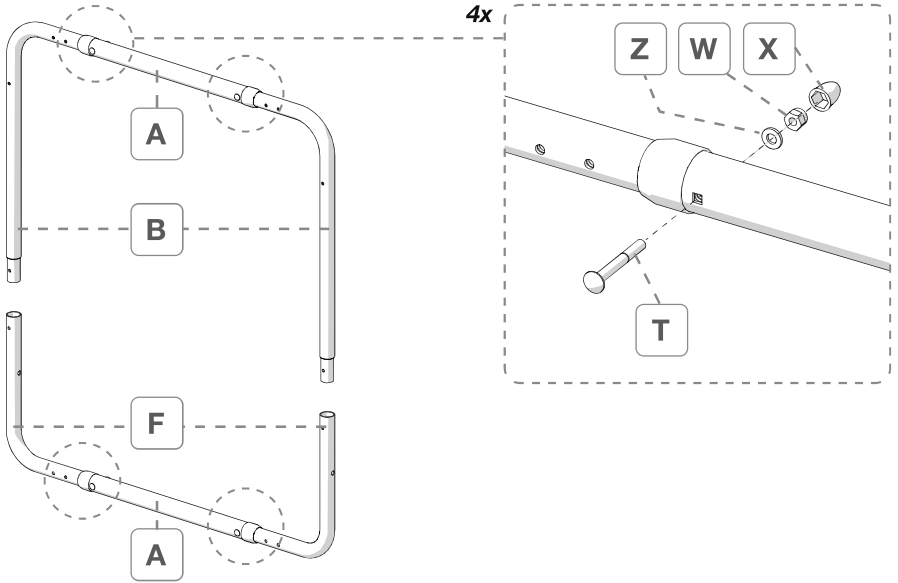

3

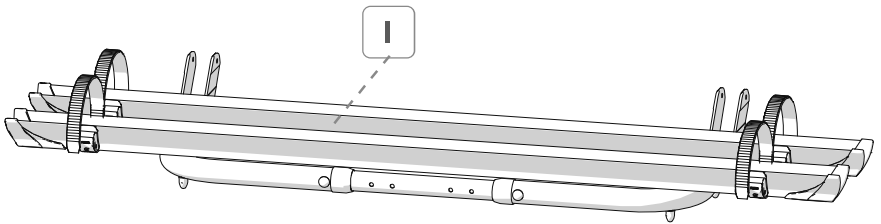

Set rack width accordingly to main structure as in step 1 (if necessary)

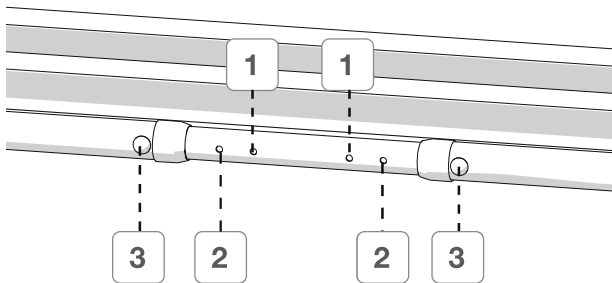

1 for lower brackets distance = 59"

2 for lower brackets distance = 61,50"

3 for lower brackets distance = 67,19"

Set both sides at the same position



**4** Adjust the rack sliding both sides to the chosen position

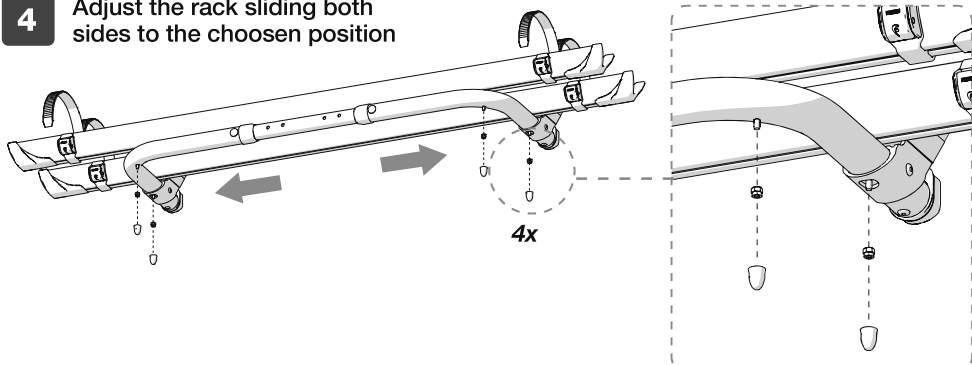

**5**

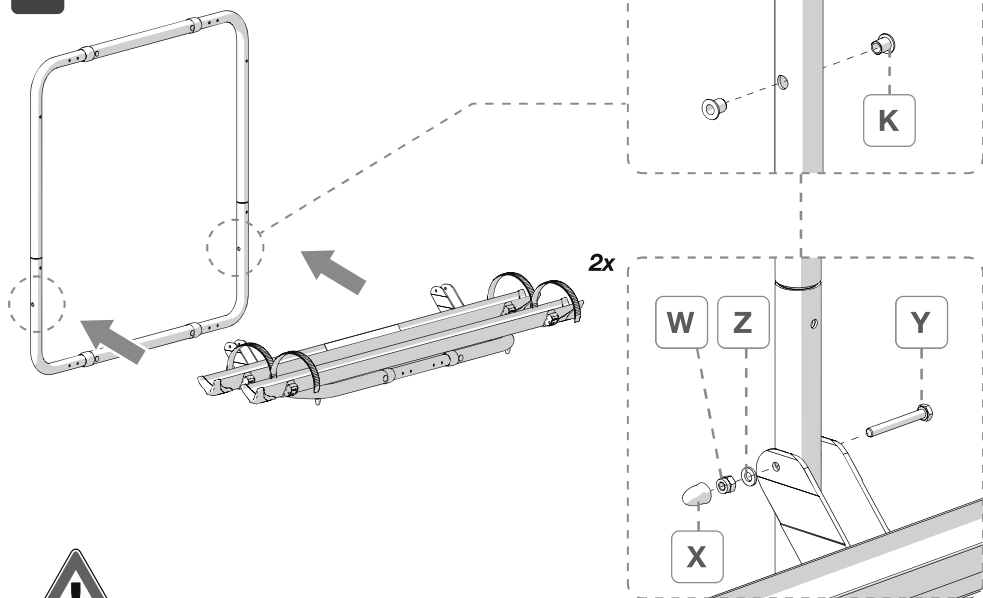

**EN** **WARNING!** Do not fully tighten the fork to the tube, leave 2mm space.

**FR** **ATTENTION!** Ne pas serrer complètement la fourche au tube, laisser un espace de 2 mm.

**ES** **ADVERTENCIA!** No apretar totalmente la horquilla al tubo, dejar 2 mm de espacio.

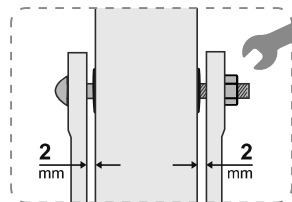

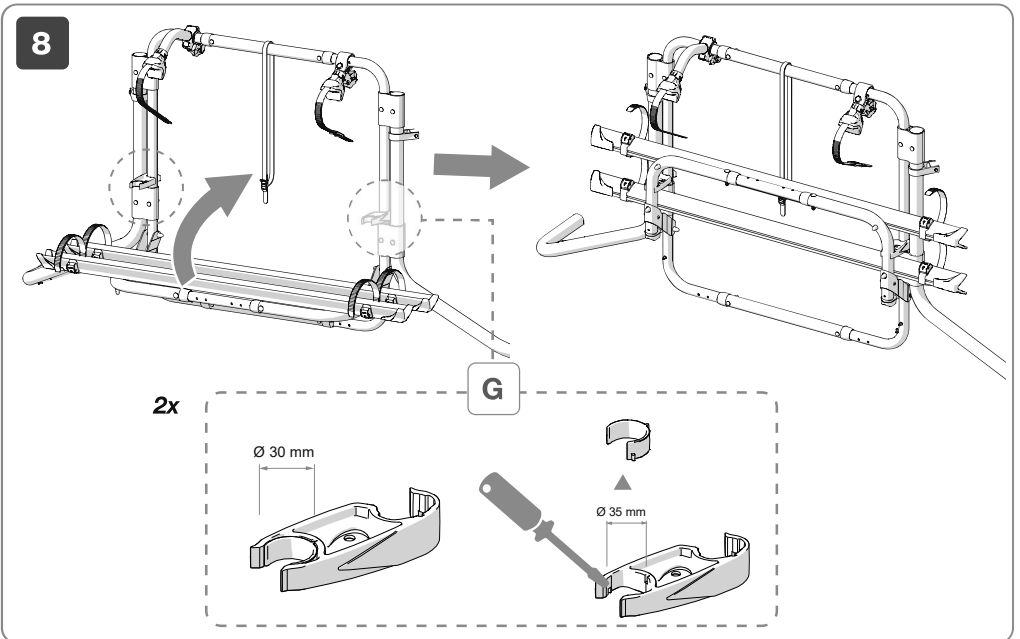
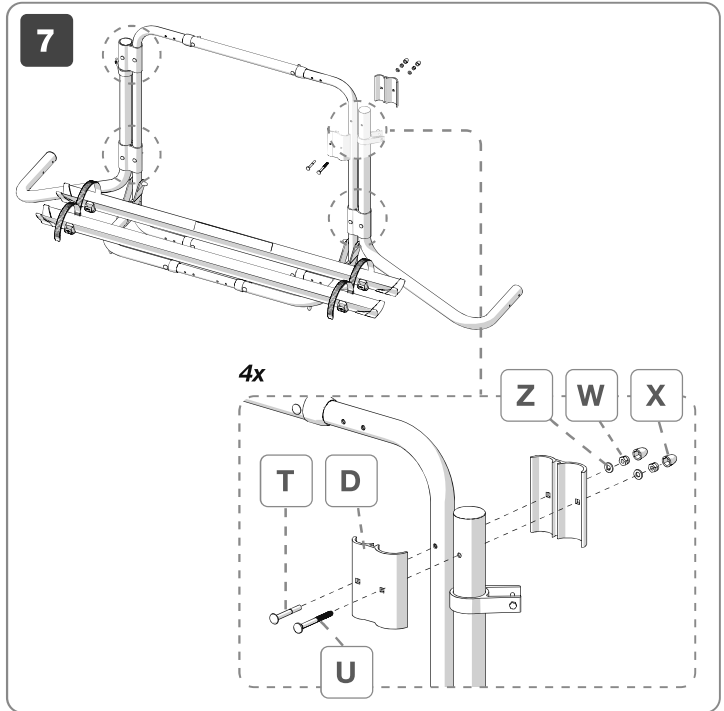
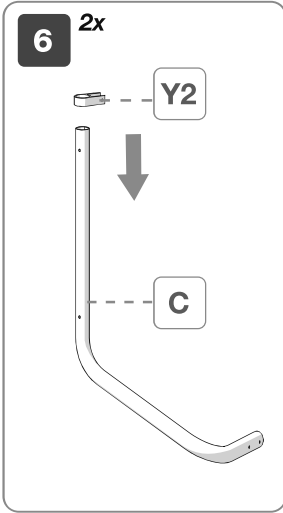



9

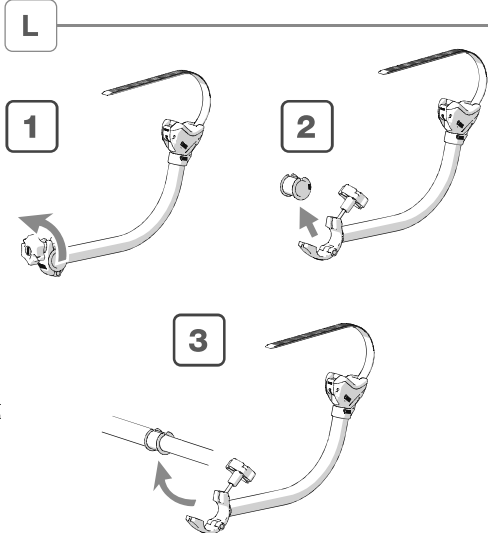
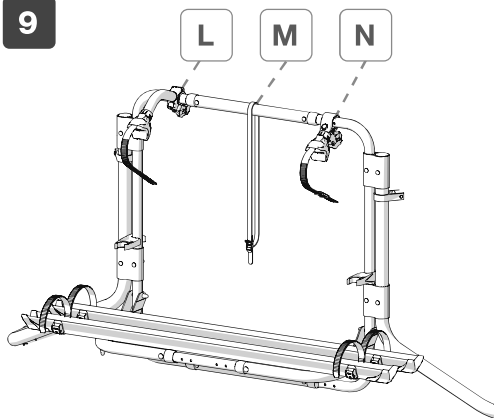

N

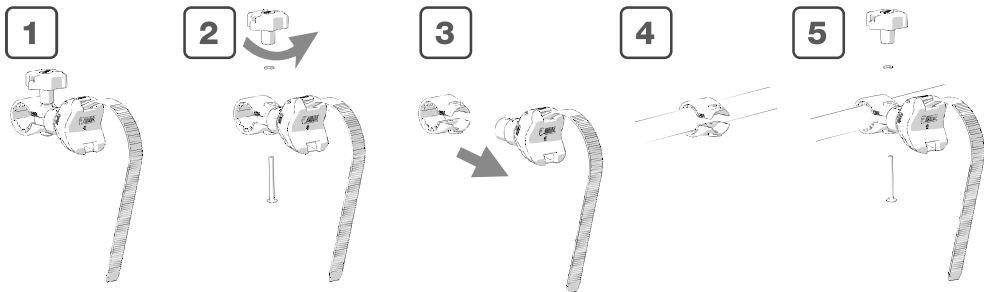

10

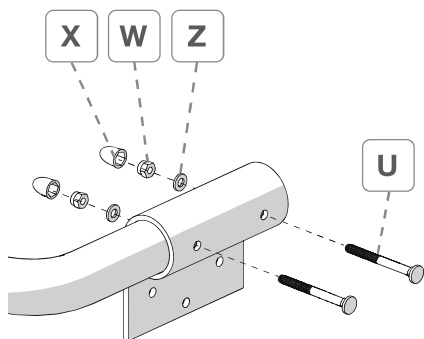
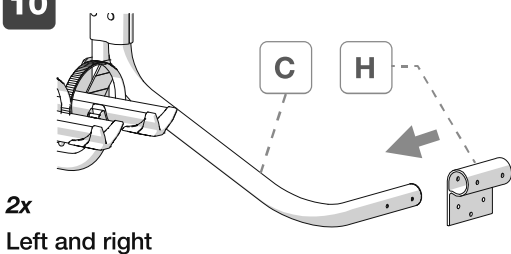



11

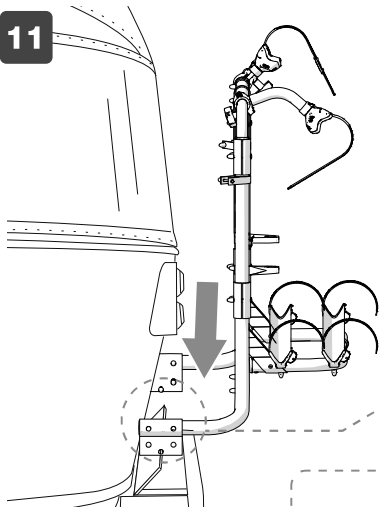

2x

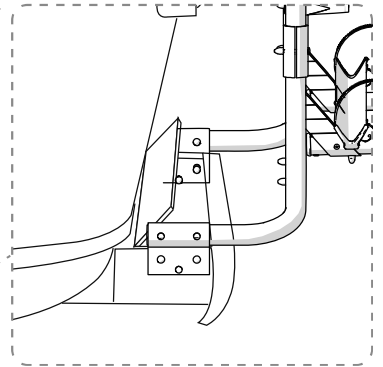

Left and right

Choose the screws set that suits the caravan structure best

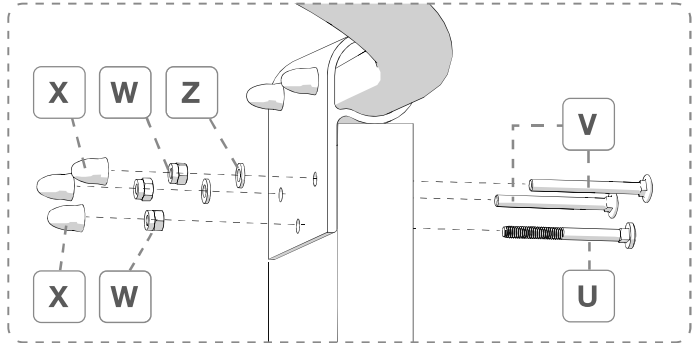

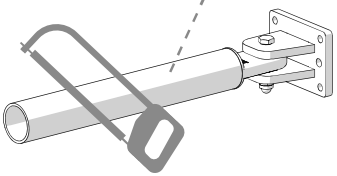

12

E

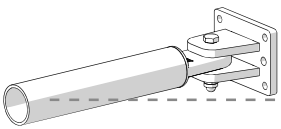

If necessary shorten pipe and make a hole



∅ 5,2 

2x

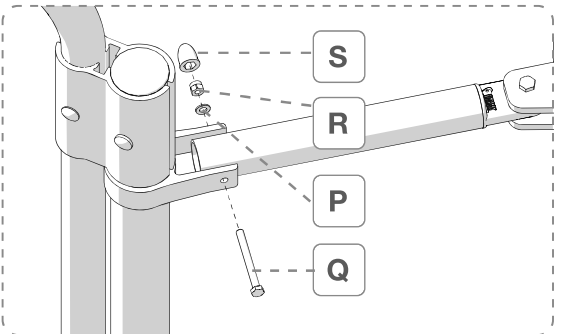

Left and right



13

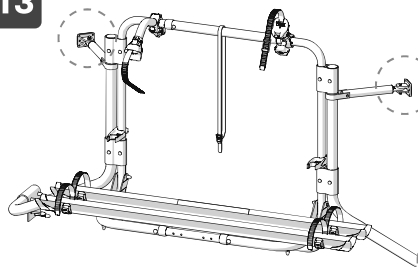

Fasten Carry-Bike to caravan  
(screws not included)

2x

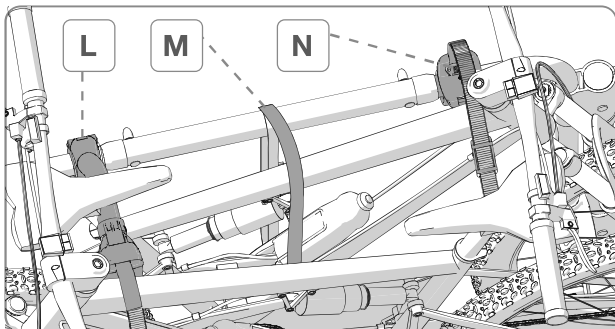
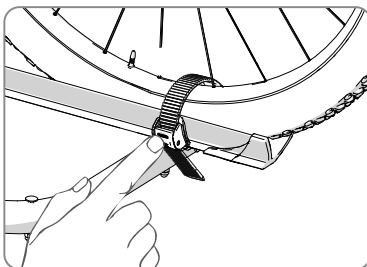
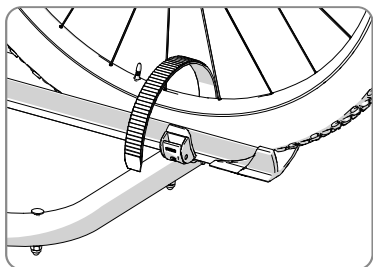
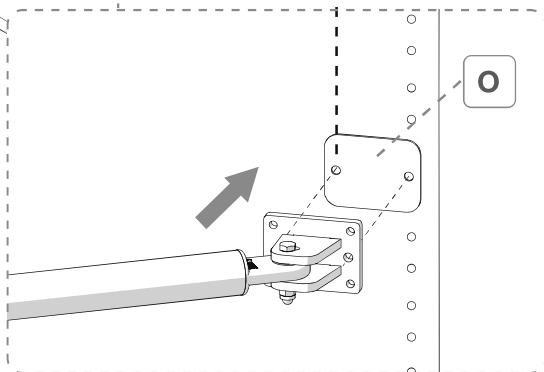

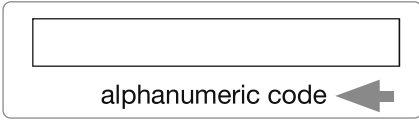

**EN** In case of problems please contact your local dealer indicating the data on the nameplate.

**FR** En cas de problème, contacter le revendeur et lui communiquer les informations reportées sur la plaquette.

**ES** En caso de cualquier problema, ponerse en contacto con su distribuidor local facilitando los datos sobre la placa.



**EN** Attention: keep the following labels and affix them to the Carry-Bike rails.

**FR** Attention : conserver les étiquettes suivantes ou collez-les sur les rails du Carry-Bike.

**ES** Atención: guardar las siguientes etiquetas o pegarlas en las guías del Carry-Bike.

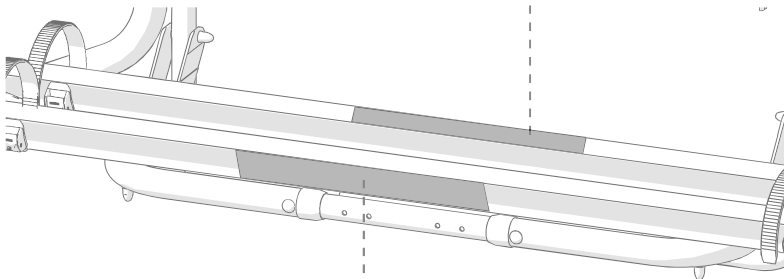
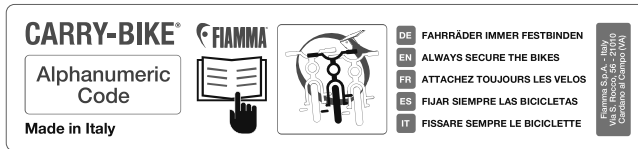

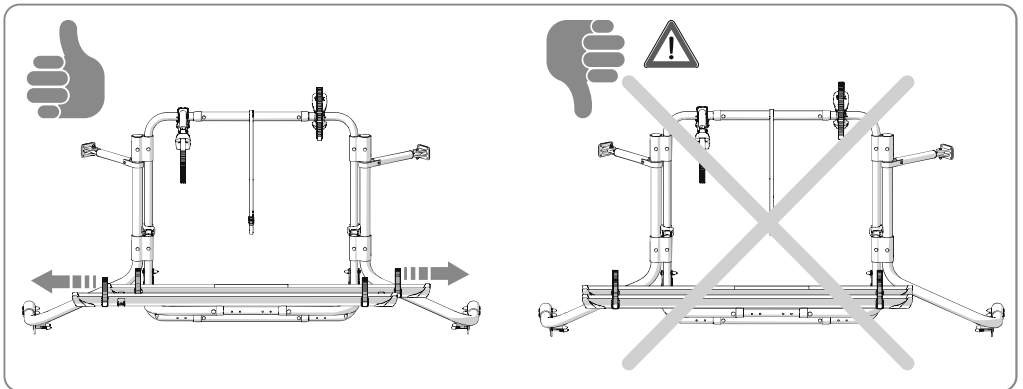
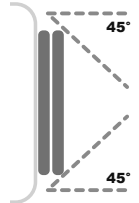
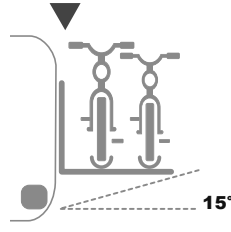
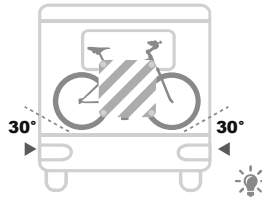
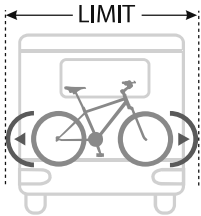
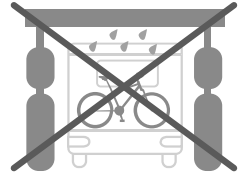
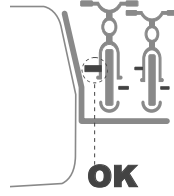
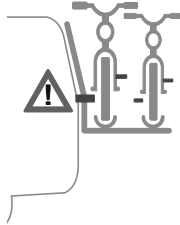
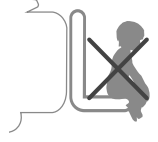
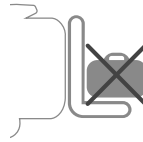
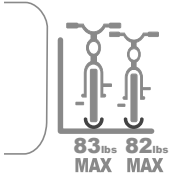



## EN

Read the following instructions and warnings carefully; failure to observe these installation and usage instructions as well as the Highway Code in the relevant country may cause severe harm or damage for which the manufacturer declines all responsibility.

In the event of an accident involving the vehicle and/or the product, ensure that the product has not been damaged. In the event of damage, contact your local retailer before moving the vehicle. Fiamma declines every responsibility for any modification of the product that may cause damage and/or injury to things and people.

Before installation, ensure compatibility with the vehicle on which the product must be installed. Checking that the wall/rear door is sufficiently solid and suitable for guaranteeing the resistance of the anchoring points is always mandatory. If not, strength and compliance with the maximum load indicated in the instructions are not guaranteed and it will be necessary to reinforce these points.

After having positioned the Carry-Bike on the rear axle of the vehicle, the normal weight distribution on both axles would be modified. This variation must not exceed the maximum permissible axle load. Never exceed the maximum permitted length and the total weight of the full-loaded vehicle.

Make sure that loading occurs following a correct weight distribution; it must be uniformly distributed (the heaviest bike must be placed near the wall of the vehicle) to ensure better stability. Always give warnings about the presence of the Carry-Bike on your vehicle, using a clearly signal for leaning loads and, in case of limited rear visibility, use the additional rear-view mirrors. Take into account the presence of the Carry-Bike, paying attention while driving and especially during reversing manoeuvres, particularly if you have a parking assist system.

Always comply with speed limits and the Highway Code. The speed should always be suitable to traffic conditions and transported load.

Check periodically the bicycle rack to make sure it is firmly attached, especially during the first kilometres from the installation and always before and after long trips, to avoid damage of the Carry-Bike/vehicle. Regularly check rubber parts under the upper and/or lower brackets, as well as the belts; if they are porous or worn, replace them immediately.

It is advisable to remove the batteries from bicycles, before loading them on the carry-bike while traveling.

## FR

Lire attentivement les instructions de montage et conseils d'utilisation suivants. Le non-respect de ces conseils d'installation ou d'utilisation mais aussi des normes relatives au code de la route du pays de circulation peuvent causer de graves dégâts qui ne pourront aucunement engager la responsabilité du fabricant.

En cas d'accident impliquant le véhicule et/ou le produit, vérifier que le produit n'a pas été endommagé. Dans le cas contraire, contacter le concessionnaire avant de déplacer le véhicule. Fiamma décline toute responsabilité quant aux éventuelles modifications apportées au produit pouvant entraîner des dommages et/ou lésions aux choses et aux personnes.

Avant de procéder au montage, s'assurer de la compatibilité du produit devant être installé sur le véhicule. Il est obligatoire de vérifier que la paroi/le hayon du véhicule est suffisamment solide ou qu'elle/il est adapté/e pour garantir la résistance des points de fixation.

Suite à l'installation du Carry-Bike sur le train arrière du véhicule, il y aura une modification du poids par rapport à une distribution normale sur les deux essieux. Cette variation ne doit pas dépasser la charge maximale autorisée par essieu. Ne jamais dépasser la longueur maximale admise et le poids total autorisé du véhicule chargé.

Dans le cas contraire, la bonne tenue et la capacité maximale de chargement ne seront plus respectées et il faudra renforcer la paroi ou le hayon. Le chargement doit se faire en respectant une correcte distribution du poids : la charge doit être distribuée de manière homogène (les vélos les plus lourds doivent être placés sur les rails les plus proches de la paroi du véhicule) pour garantir une plus grande stabilité et sans dépasser la largeur du véhicule. Toujours signaler la présence d'un porte-vélos par l'intermédiaire d'un panneau de signalisation pour chargement dépassant le gabarit du véhicule et, en cas de visibilité arrière réduite, l'utilisation de rétroviseurs supplémentaires est recommandée. Conduire avec un porte-vélos demande de savoir adapter son style de conduite en faisant tout particulièrement attention aux manœuvres de marche arrière, spécialement si le véhicule est équipé de dispositif d'aide au stationnement.



Respecter les limitations de vitesse et le code de la route. La vitesse doit toujours respecter les conditions de circulation sur route et la charge transportée.

Contrôler régulièrement l'état des éléments de fixation du porte-vélos, en particulier après avoir parcouru les premiers Km suivant l'installation et, à chaque occasion, avant et après les plus longs trajets pour éviter d'endommager le Carry-Bike et/ou au véhicule. Vérifier régulièrement les éléments en caoutchouc sous les étriers supérieurs et/ou inférieurs ainsi que les sangles; s'ils devaient s'avérer poreux ou abîmés, remplacez-les immédiatement.

Conseil pour le transport: avant de charger le vélo électrique sur le porte-vélos, il est recommandé de retirer la batterie.

**ES**

Leer atentamente las siguientes instrucciones y advertencias; el incumplimiento de estas normas de montaje y uso y de las normas del código de circulación del país por el que se circula puede causar daños graves sobre los que el fabricante declina toda responsabilidad.

En caso de accidente que afecte al vehículo o al producto, asegúrese de que el producto no haya sufrido daños. Si hay algún daño, póngase en contacto con su distribuidor local antes de mover el vehículo. Fiamma no se hace responsable de cualquier modificación del producto que pueda causar daños o lesiones a cosas y personas.

Antes del montaje, asegúrese de que el producto sea compatible con el vehículo en el que se instalará. Es obligatorio comprobar siempre la solidez suficiente de la pared/portón del vehículo y que sea adecuada para garantizar la resistencia de los puntos de anclaje. De lo contrario, la sujeción y el cumplimiento de la carga máxima indicada en las instrucciones no están garantizados y será necesario reforzarla.

A consecuencia de la instalación del Carry-Bike sobre el eje trasero de vehículo, la normal distribución de los pesos sobre los dos ejes se modifica. Es importante no sobrepasar nunca la carga máxima admisible por cada eje (verificar en el permiso de circulación). No superar nunca la longitud máxima permitida y el peso total máximo del vehículo a plena carga.

La carga tiene que estar distribuida uniformemente y según la correcta distribución del peso (las bicis más pesadas cerca de la pared del vehículo) para garantizar la máxima estabilidad, y no tiene que superar la anchura máxima del vehículo. Indicar siempre la presencia del portabicicletas con una señal de cargas salientes y en caso de visibilidad trasera reducida, es aconsejable utilizar los espejos retrovisores adicionales.

Tener en cuenta la presencia del Carry-Bike, prestando atención durante la conducción y especialmente mientras se realizan maniobras de marchas atrás, en particular si el vehículo está equipado con sensores de aparcamiento.

Respetar siempre el límite de velocidad y las normas de circulación. La velocidad debe adecuarse al estado del tráfico y a la carga que se transporta

Controlar periódicamente el estado de fijación del portabicicletas, sobre todo después de los primeros km tras el montaje y cada vez antes y después de los viajes más largos. Para evitar daños del Carry-Bike y/o del vehículo, revisar regularmente las partes de goma debajo de los soportes superiores y / o inferiores, así como las correas; sustituirías inmediatamente si están porosas o desgastadas.

Se recomienda sacar las baterías de las bicicletas, antes de cargarlas en el carry-bike durante el viaje.

**EN** **Warranty Fiamma.** In case of defects with regards to materials and manufacturing, the customer is entitled to the warranty in accordance with local laws and regulations of the country in which the product was purchased.

**FR** **Garantie Fiamma.** En cas d'un défaut de conformité du produit, le consommateur pourra faire valoir ses droits de recours en garantie selon les modalités prévues par les dispositions légales locales, pour autant que les conditions de recours soient satisfaites.

**ES** **Garantía Fiamma.** En caso de fallos o defectos de material y de fabricación, el cliente puede hacer valer la garantía de acuerdo con las leyes y reglamentaciones del país en el que el producto haya sido comprado.





**RAIL PLUS**

Item No. 98656M566

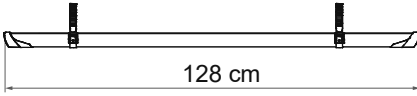

**RAIL PREMIUM**

Item No. 98656M131

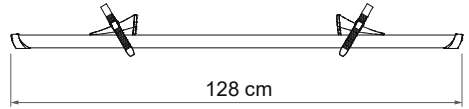

**BIKE-BLOCK PRO D**

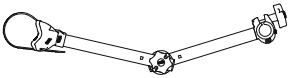

**BIKE-BLOCK PRO S**

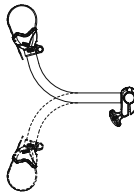

**BIKE-BLOCK PRO S D**

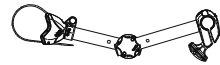

**BIKE FRAME ADAPTER**

Item No. 06602-01-



**PLASTIC SIGNAL**

Item No. 98782-005

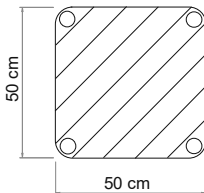

**ALU SIGNAL**

Item No. 98782-010

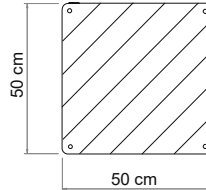

**CABLE-LOCK**

Item No. 98656-338

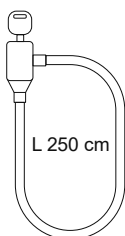

**LICENCE PLATE CARRIER**

Item No. 06146C01-

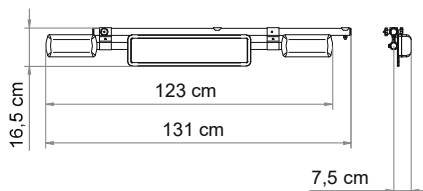



[fiamma.com](http://fiamma.com)

**Fiamma S.p.A. - Italy**

Via San Rocco, 56  
21010 Cardano al Campo (VA)

All rights reserved.  
**Fiamma S.p.A.**  
reserves the right to modify at any time,  
without notice, prices, materials,  
specifications and models or to cease  
production of any model.