



## Spike System Process Guide

### CONTENTS:

- Page 1-3: Setup
- Page 4: Mashing Tun
- Page 5-6: Sparging
- Page 7: Whirlpool
- Page 8: Drain to Conical
- Page 9: Cleaning

# PROCESSES GUIDE



# SETUP

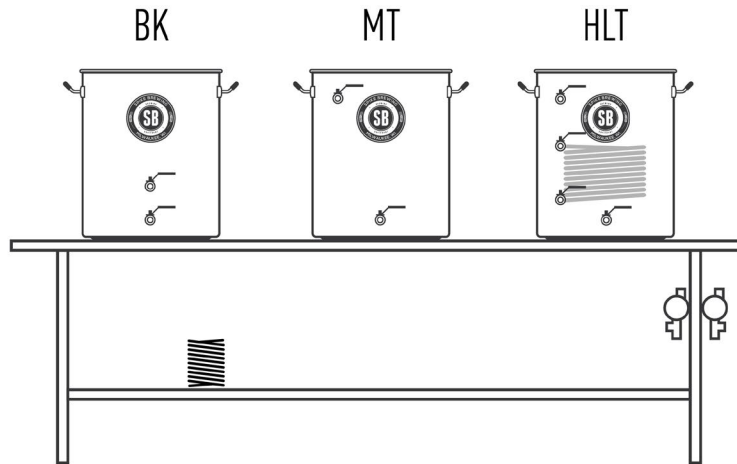

- Assemble the Spike System as shown [HERE](#).

**Pro tip:** Before you get started, make sure that you auto-tune your HLT PID controller. This insures proper calculations resulting in efficient use of the heating element. You only need to do this for your HLT PID before first use.

- To auto-tune, bring your kettle to approximately 150 degrees, once close, press the SET and < buttons until you see PASS. Enter code 0033 and press set. Select F02 and press Set. Set At to YES and press the set button again until you see your PV again. You'll see ATU blink in the bottom right while it auto tunes. The auto tune process isn't a precise period, but it typically will run about 30 to 60 minutes.
  - To set your temperature, press set once, then up or down to change the temperature accordingly, then press set until you see your temperature in PV again. Make sure all valves are closed
- Make sure all valves are closed
  - Place your false bottom in your mash tun and connect the pickup tube.
  - Set up the hoses as shown in **Figure 1**. (next page)
    - Connect a 6 ft. hose from the Mash Tun (MT) drain to the wort pump inlet (**Yellow**)
    - Connect a 6 ft. hose from the wort pump outlet to Hot Liquor Tank (HLT) bottom HERMs port (**Green**)
    - Connect a 4 ft. hose from the HLT HERMs outlet to mash tun top recirculation port (**Purple**)
    - Connect a 4 ft. hose from the drain of the HLT to the water pump inlet (**Red**)
    - Connect a 4 ft. hose from the water pump outlet to the HLT top recirculation port (**Blue**)



# SETUP

Fig. 1

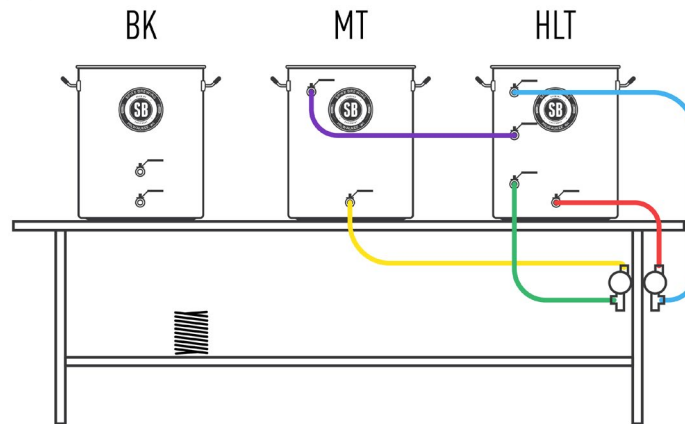

**Pro Tip:** The water pump is only used to pump clean water and therefore doesn't need cleaning at the end of your brew day.

- Determine your strike water amount for your specific brew and fill the mash tun.

**Pro Tip:** Consider the dead space under the false bottom and the amount in the HERMS coil when filling your mash tun. If this isn't accounted for, your mash will end up a little thicker than desired. For more information on efficiency visit our recommendations [HERE](#).

- Fill the HLT so your HERMs coil is covered (~75% full)
- Set your HLT roughly 10 degrees hotter than your desired mash temp using the HLT controller.
  - When you mash in this will drop your strike water temp down to your desired mash temp.
- Turn the HLT element on
- Put the lid back on the HLT

**Pro Tip:** Once your strike water and HLT are warmed up you can add any minerals to adjust your water chemistry

- Put the lid on the MT
- As shown in **Figure 2:** (next page)
  - Open your top recirculation MT valve (6)
  - Open the MT drain valve (5)
  - Open the HLT drain valve (1)
  - Open both HLT HERMs ports (2 and 3)
  - Open the top recirc port (4)



# SETUP

Fig. 2

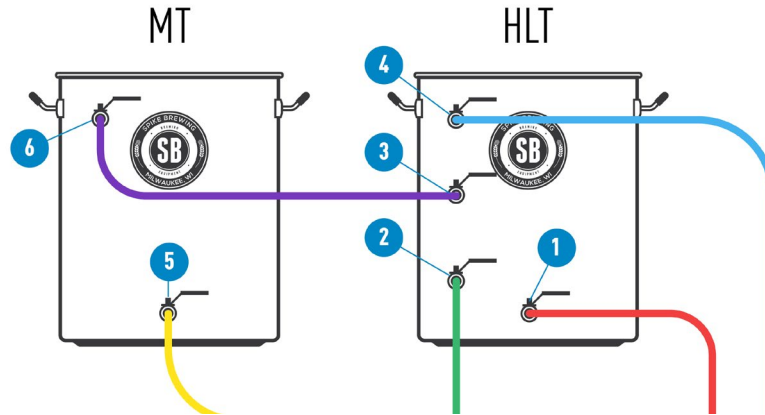

- Bleed the air from the lines of the system by opening the bleeder valve on the bottom of each pump until a solid stream flows out. The solid stream tells us all air is out of the lines and the pumps are primed.
- Open the outlet valves on each of the pumps
- Turn on your water pump. You can run the water pump wide open at this time.
- Turn on your wort pump. We usually run the wort pump wide open when heating the mash tun.
- Watch your MT PID until it gets to your desired strike temp

**Pro Tip:** The MT PID is a readout only. The MT temp is controlled by the HLT via the submerged heat exchanger. To increase the MT temp, increase the HLT temp. Set the HLT a few degrees hotter than your desired MT temperature to account for hose temperature loss.

- The wort pump can be turned off in preparation for mashing in

**Pro Tip:** Add cold water to the HLT if temperatures need to come down a few degrees above your desired mash temps.





# MASHING TUN

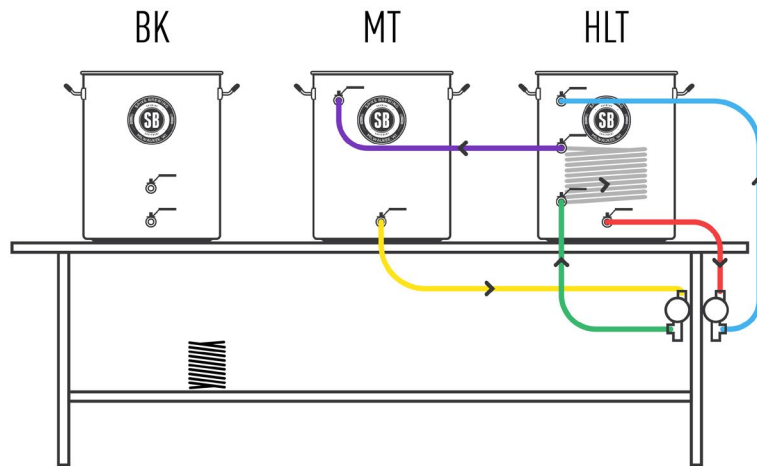

- Slowly add your grain while constantly stirring to avoid any dough balls. This will drop your strike water down to your desired mash temp.
- When recirculating the MT, you'll want to throttle the flow of the MT recirc port down to about 1/4 flow rate to prevent grain bed compaction

**Pro Tip:** Whenever you're reducing flow, you always want to throttle the valve after the pump (not before the pump); throttling the valve on the return port of the kettle is always preferred and gives the best control. Otherwise it can cause cavitation and possible damage the pump.

- Continuously recirculate the mash for your desired time frame until all starches have been converted to sugars.

**Pro Tip:** Since the Spike System uses a constantly recirculating mash technique you'll only need to mash for 30-45 minutes until full starch to sugar conversion is achieved.

**Pro Tip:** If you would like to 'mash out' you can turn the HLT up to roughly 175°F during the last 10 minutes while mashing. This will allow for mashing out at 170°F.

**Pro Tip:** Since the Spike System uses a constantly recirculated mash technique there is no need to vorlauf (clarification of wort at the end of a mash) which will save about 20 minutes on your brew day.



# SPARGING

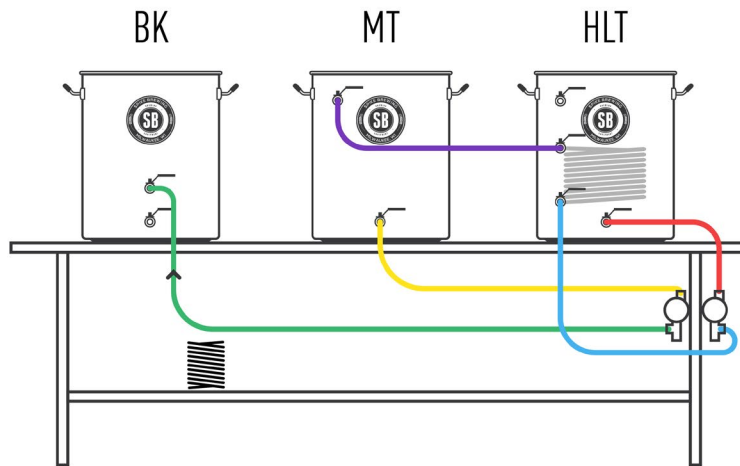

- When your mash is complete, turn off the pumps and close all the valves
- We recommend connecting 2 feet of the silicone tubing to the side pickup tube on the mash tun. The tubing will float on top of the grain bed allowing for a nice even recirculation over the grain bed.
- Move the hose attached to the inlet of the HERMs port to the Boil Kettle (BK) whirlpool port
- Move the hose attached to the HLT top recirc port down to the now vacated inlet of the HERMs port

**Pro Tip:** This will pump clean hot water through your HERMS coil clearing it of any wort and cleaning the inside at the same time

- Open the HLT drain valve and the HERMs inlet and outlet valves
- Purge the water pump
- Turn on water pump and open the valve
- Slowly open the MT top recirc valve until you have a small trickle of water over grain bed
- Leave an inch or two of water over the grain bed. This will naturally disperse your sparge water over the grain bed. As your sparge water trickles through the grain bed, it washes the sugars from the grain into the boil kettle.
- Open your MT drain valve
- Crack open the whirlpool port valve on the BK
- Purge the wort pump



# SPARGING

- Turn your wort pump on
- Slowly drain the wort from the MT to the BK
- Match the sparge and MT drain flows so the sparge in and wort out to the BK are the same. Keep them both down to a trickle

**Pro Tip:** Once the wort level is above the element in the BK, turn the BK element on. This will allow your BK to be close to boil by the time you finish your sparge and help reduce your brew day by about 30 minutes.

- To set your temperature, press set once, then up or down to change the temperature accordingly, then press set until you see your temperature in PV again.
- Do not put your lid back on the BK during the boil
- Once you've reached your pre-boil volume, turn off the pumps and close the valves
- As you reach your boiling temp, you can adjust the power % up or down to keep the perfect rolling boil and avoid any boil overs. If you see a boil over happening, you can quickly turn off the element or stir down or squirt the hot break material and adjust the power %, as stated before, when you turn the element back on.
- You can add your bittering hops now and start your boil timer
- Once the boil is completed, turn off your BK element

**Pro Tip:** There should be about 3-4 gallons of water in your HLT. Turn your HLT element back on when your boil is complete and heat water to 170°F degrees. This water will be used to CIP the system after your brewing is done.



# WHIRLPOOL

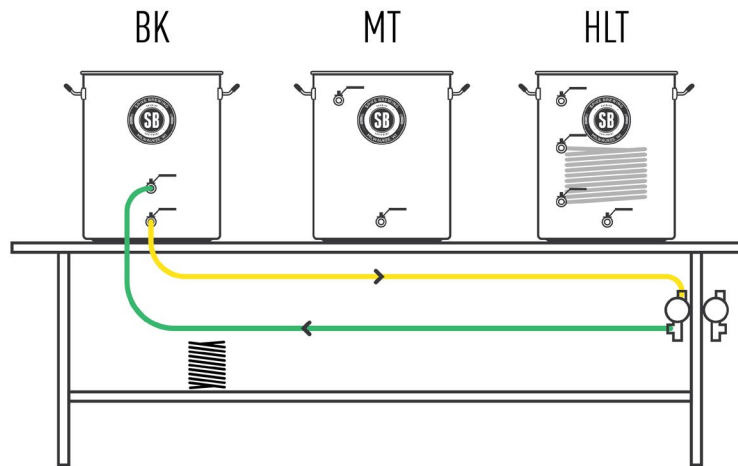

- Move the hose from the outlet of the MT to the outlet of the BK
- Open the drain and whirlpool valves on kettle
- Purge air in pump if needed
- Open the valve on wort pump
- Turn on the wort pump
- Whirlpool for 10-15 minutes to form a tight hop cone. Our specially designed stepped bottom will keep the trub material in the lower step and the side pickup on the top step will give clear wort into your fermenter
- Turn off the wort pump
- Let the wort rest for 10-15 minutes



# DRAIN TO CONICAL

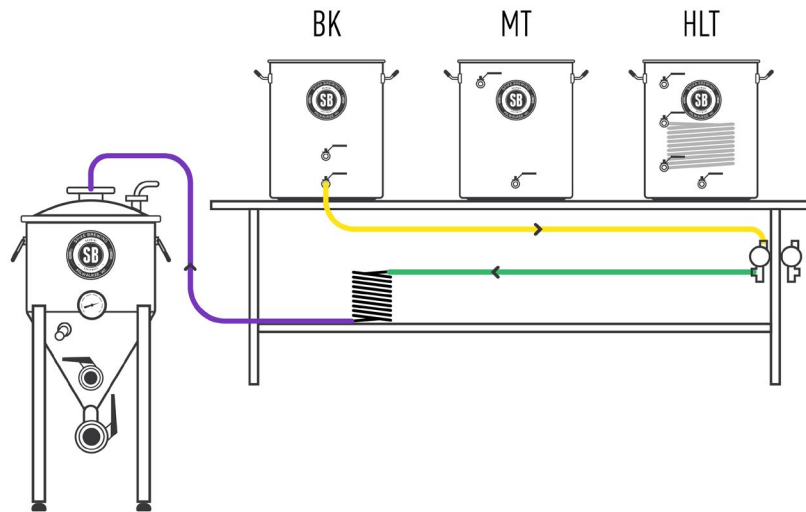

- Grab your counterflow wort chiller
- Move your hose connected to the BK whirlpool port and connect it to the inlet of the wort chiller (wort side)
- Connect a hose from the outlet of the wort chiller to your Spike Conical (wort side)
- Connect a cold-water source to the inlet of the wort chiller (water side)
- Connect a hose from the water outlet of your wort chiller into a drain (sink, floor drain, HLT, etc.) (water side)

**Pro Tip:** The first 3-4 gallons from the output of the chiller will be very hot. This water can be collected in your HLT and used to CIP reducing your water usage.

- Open your BK drain valve
- Purge your wort pump of air
- Move your mash tun temp probe to the temp probe port of the wort chiller to monitor actual temps of your wort.
- Turn on your wort pump
- Open your wort pump slowly until your desired yeast pitching temp is read on the MT PID readout
- Drain until BK is empty
- Turn off the wort pump and close all the valves
- Add yeast and seal your conical
- Learn how to use the one of our conical fermenters [HERE!](#)



# CLEANING

- Drain any wort left in your MT and hop material out of your BK
- Scoop or dump your grain out of MT
- Rinse the MT and BK
- Check that the HLT is holding at CIP temp
- Connect a 4 ft hose from the HLT drain port to the inlet of the water pump
- Connect a 6ft hose from the outlet of the water pump to the top recirculation port of the MT
- Open the valves and turn on the water pump until all the water from the HLT is transferred into the MT (you don't need to clean the HLT since it was only holding water during the brew)
- Close all the valves and turn off the water pump
- Add your brewery wash chemicals to your MT
- Scrub the MT down to remove any hop material from the sides of your kettle
- Switch the hose connected to the drain of the HLT to the outlet of the HERMs
- Connect a 4 ft hose from the drain port of the MT and connect it to the inlet of the wort pump
- Connect a 6 ft hose from the outlet of the wort pump to the inlet of the HERMs
- Open all the valves and turn on both pumps
- Open and close all the valves, including the air bleed valves, as the brewery wash is running through them
- Close all valves and turn off the pumps
- We typically go from the mash tun to the pump into the Herms coil and back into the MT while working the valves
- Then using the other pump, we go from the MT to the other pump to the BK.
- Next go from BK to chiller and then drain.
- Then rinse the system by using clean water following the above steps.

**Pro Tip:** You can add Star San with your rinse water to rinse and sanitize at the same time

VISIT [SPIKEBREWING.COM/SYSTEMS](https://spikebrewing.com/systems) TO SEE THE COMPLETE ASSEMBLY AND BREW DAY VIDEOS.