

Spike Solo System

User Guide



Congrats on securing your new Spike Solo System!

We know you're anxious to get brewing, so we made these assembly instructions and Brew Day Guide easy for you to follow and threw in a few pro tips along the way.

Grab a beer, and let's get started.

01. Assembly	2.
Kettle.....	4.
Basket.....	6.
Assembled.....	8.
Wort Chiller.....	10.
Pump.....	12.
Hoses.....	14.
02. Brew Day Guide	15.
Autotune the Control Panel.....	16.
Heat Strike Water.....	17.
Mashing.....	18.
Drain (Lauter).....	19.
Boiling.....	20.
Whirlpool.....	21.
Chill (Knockout).....	22.
Cleaning.....	23.

01.

Assembly

Ready to get your Solo up and running? This guide will show you how to assemble each piece of equipment with step-by-step instructions and key visuals.

Kettle

Basket

Assembled

Wort Chiller

Pump

Hoses

Assembly –

Before you begin

Make sure the elements are plugged in, and the power cords are fully twisted into position. We also recommend strain relieving the power cords so the full weight is not pulling down on the element connection. Taking these actions will certainly extend the life of your power cords.

All threaded NPT fittings require pipe tape for a leak-free seal. Put 3-4 wraps of pipe tape on the threads in a clockwise direction. If your fitting is not oriented correctly after tightening, try adjusting the tightness of the wrap and the amount of pipe tape.

Before installing parts into quick-connect (QC) fittings, be sure to lubricate them with water. This will allow them to slide into the QC fitting easily and prevent tearing the o-ring.

Assembly – Kettle

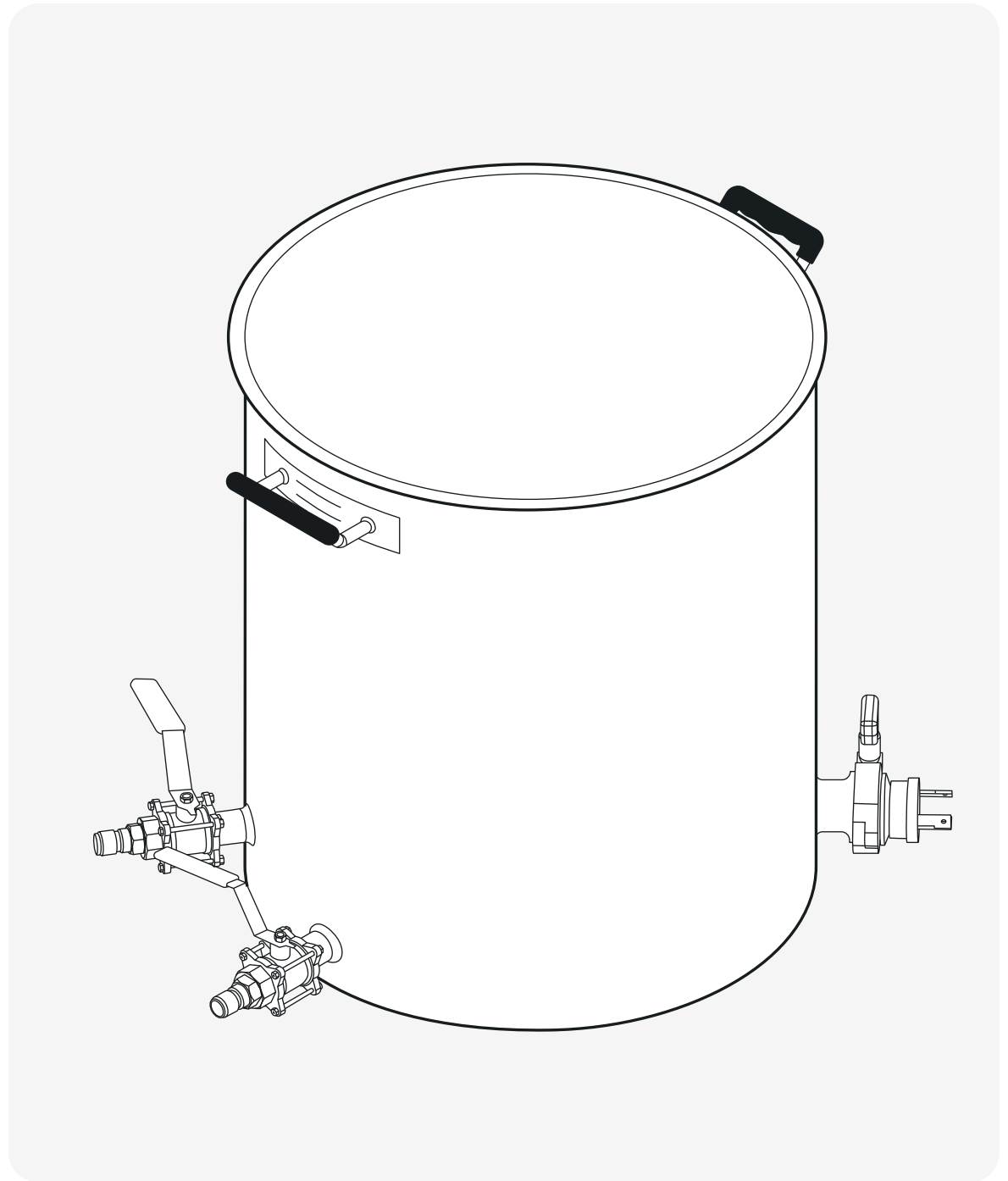

Assembly – Kettle

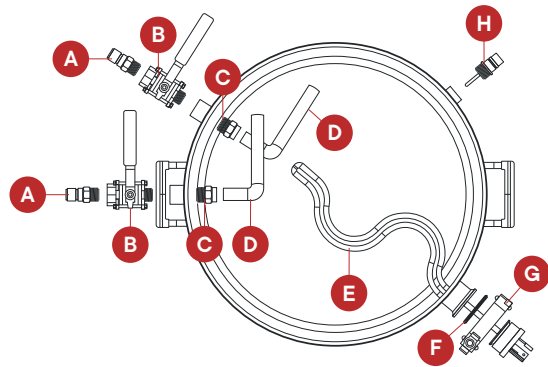

ITEM	DESCRIPTION	QTY
A	Quick Connect Fitting - MQC x MNPT	2
B	Stainless Steel Ball Valve	2
C	5/8" Quick Connect Fitting	2
D	Side Pick Up Tube	2
E	Heating Element	1
F	TC Gasket	1
G	TC Clamp	1
H	Temp Sensor	1

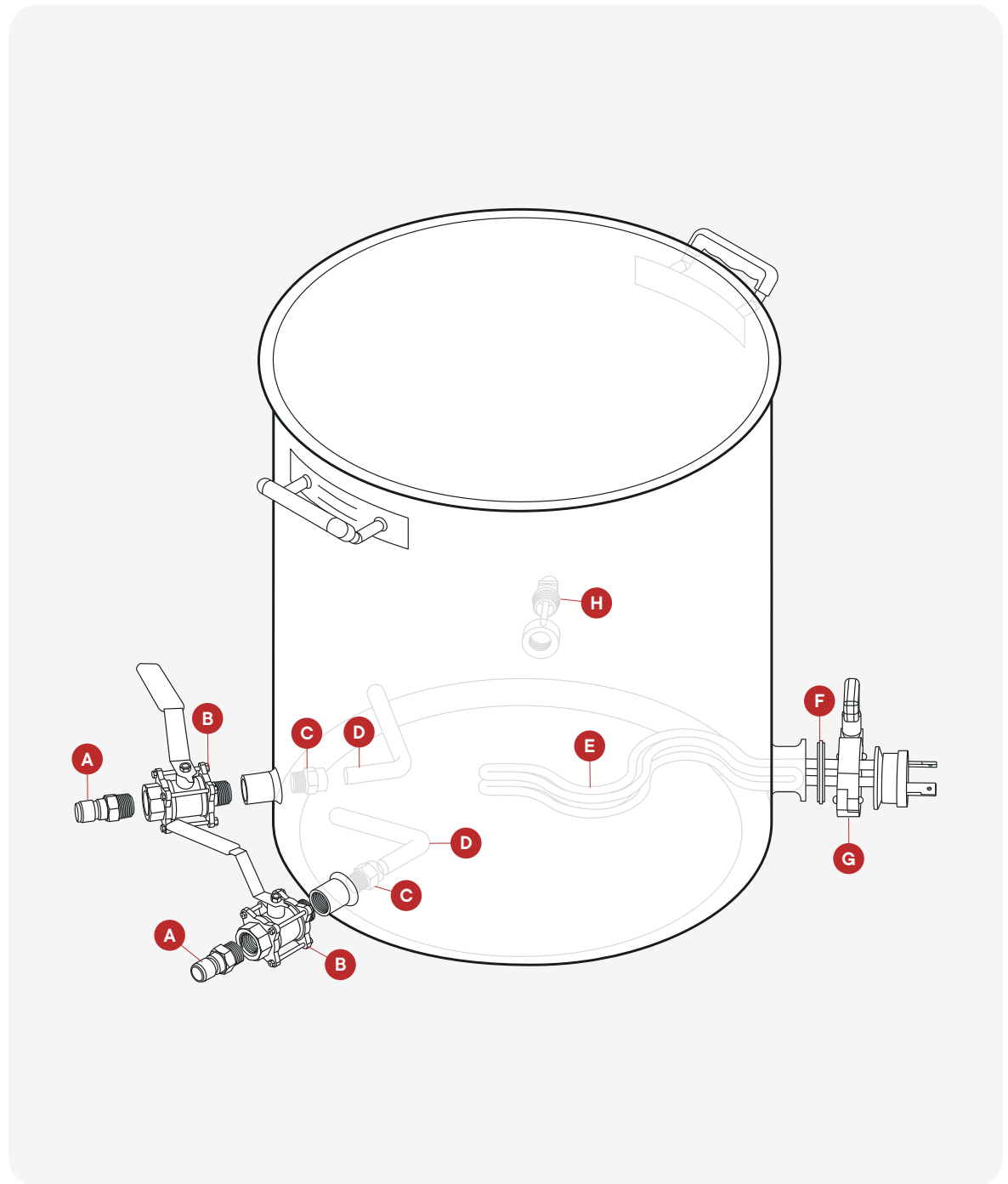

Assembly – Basket

Use 2 feet of your silicone tubing to create a sparge arm from the top recirc port. The tubing will float on top of the grain bed allowing for an even recirculation.

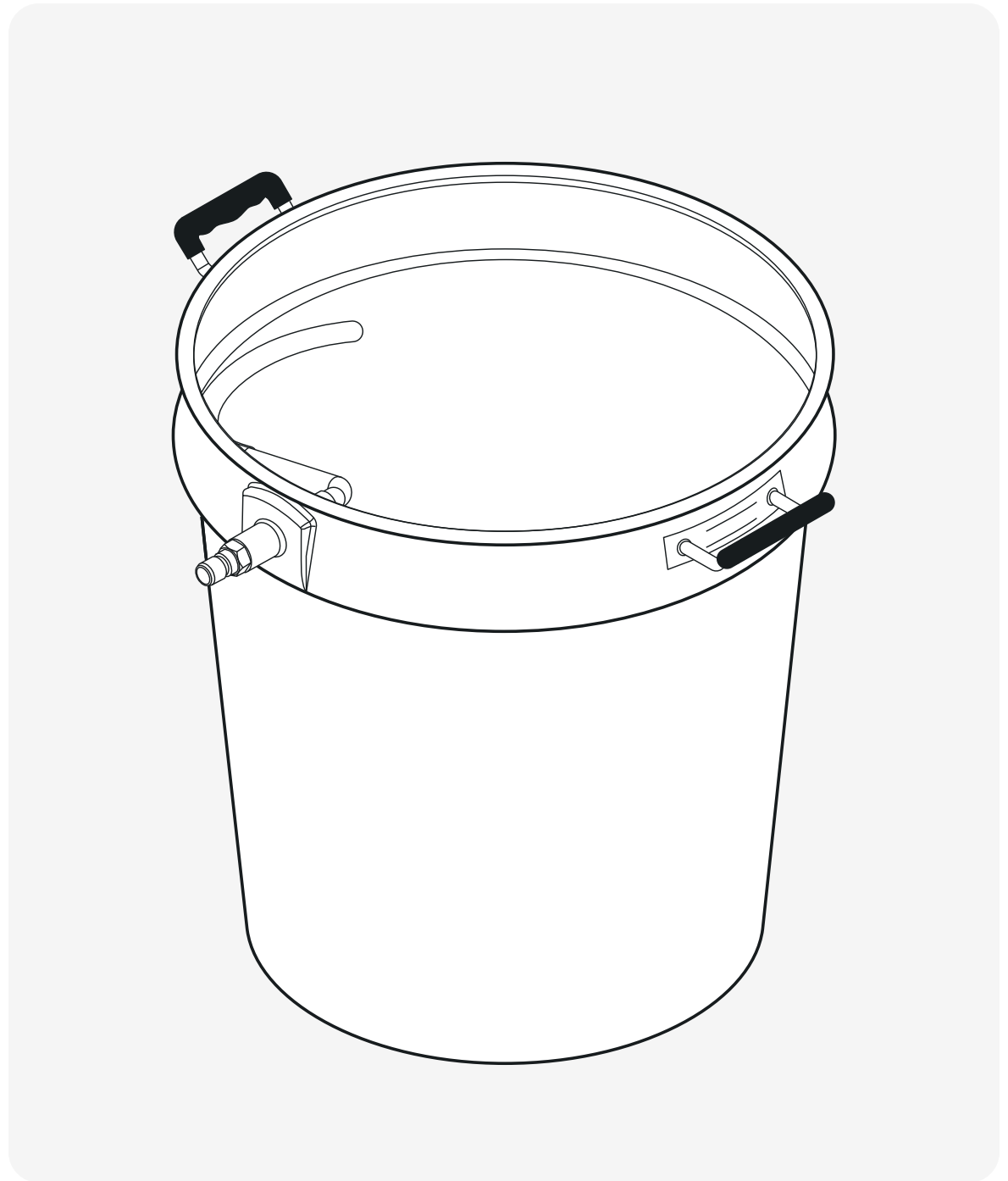

Assembly – Basket

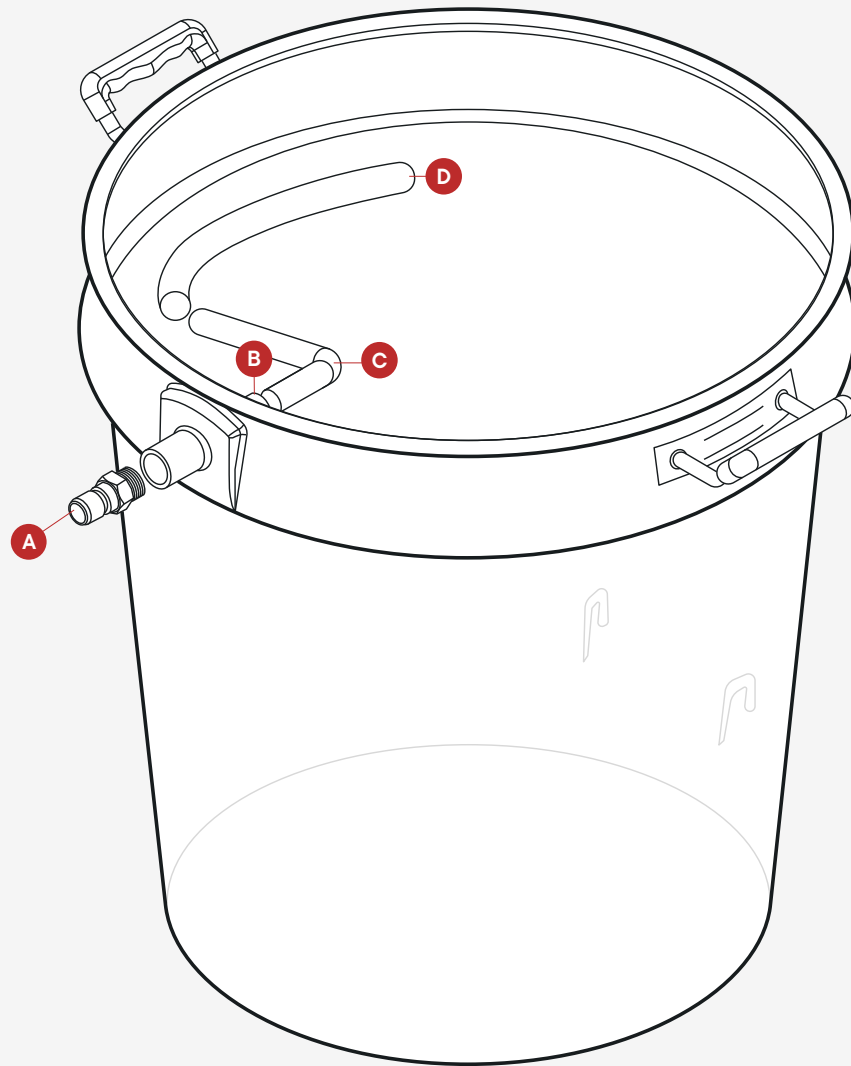
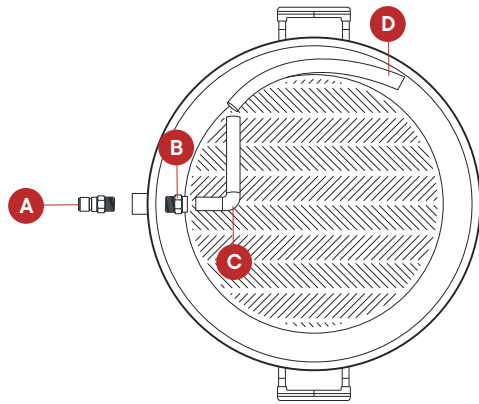

ITEM	DESCRIPTION	QTY
A	Quick Connect Fitting - MQC x MNPT	1
B	5/8" Quick Connect Fitting	1
C	Side Pick Up Tube	2
D	Mash Recirculation Hose	1

Assembly – Kettle & Basket

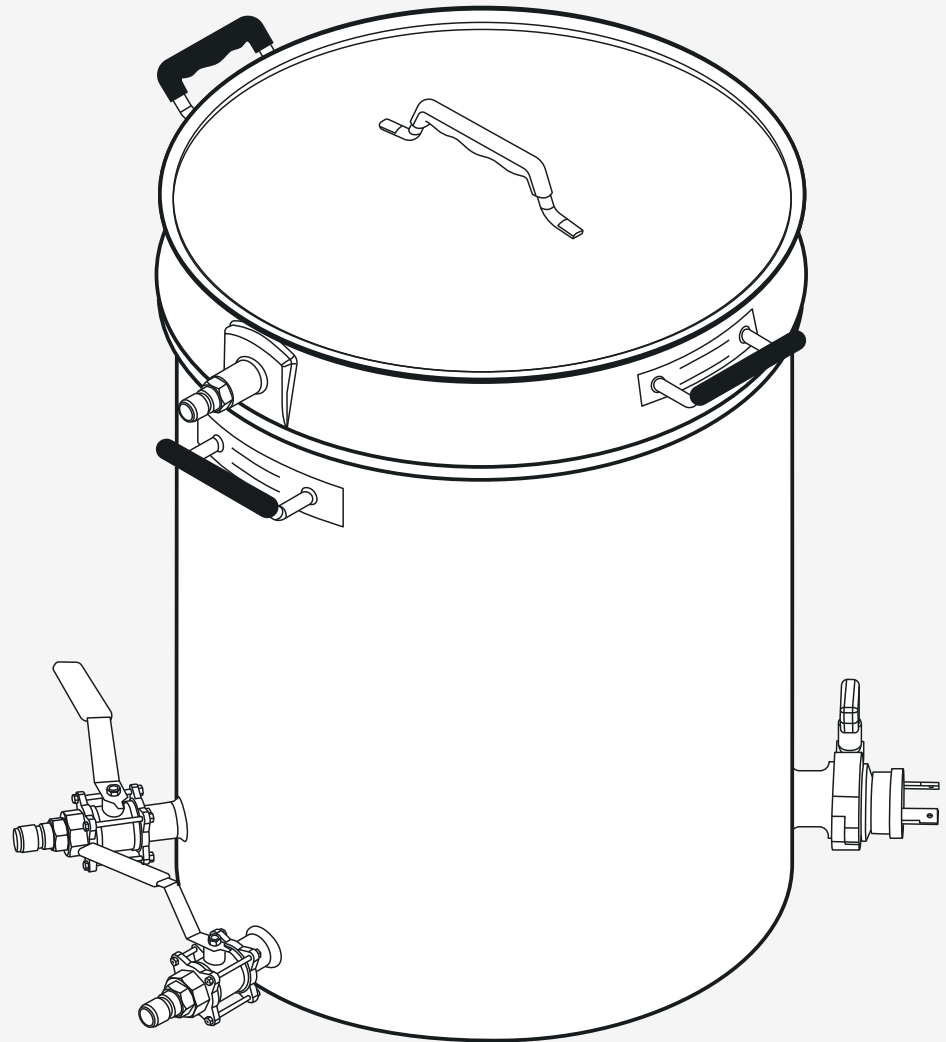

Assembly – Kettle & Basket

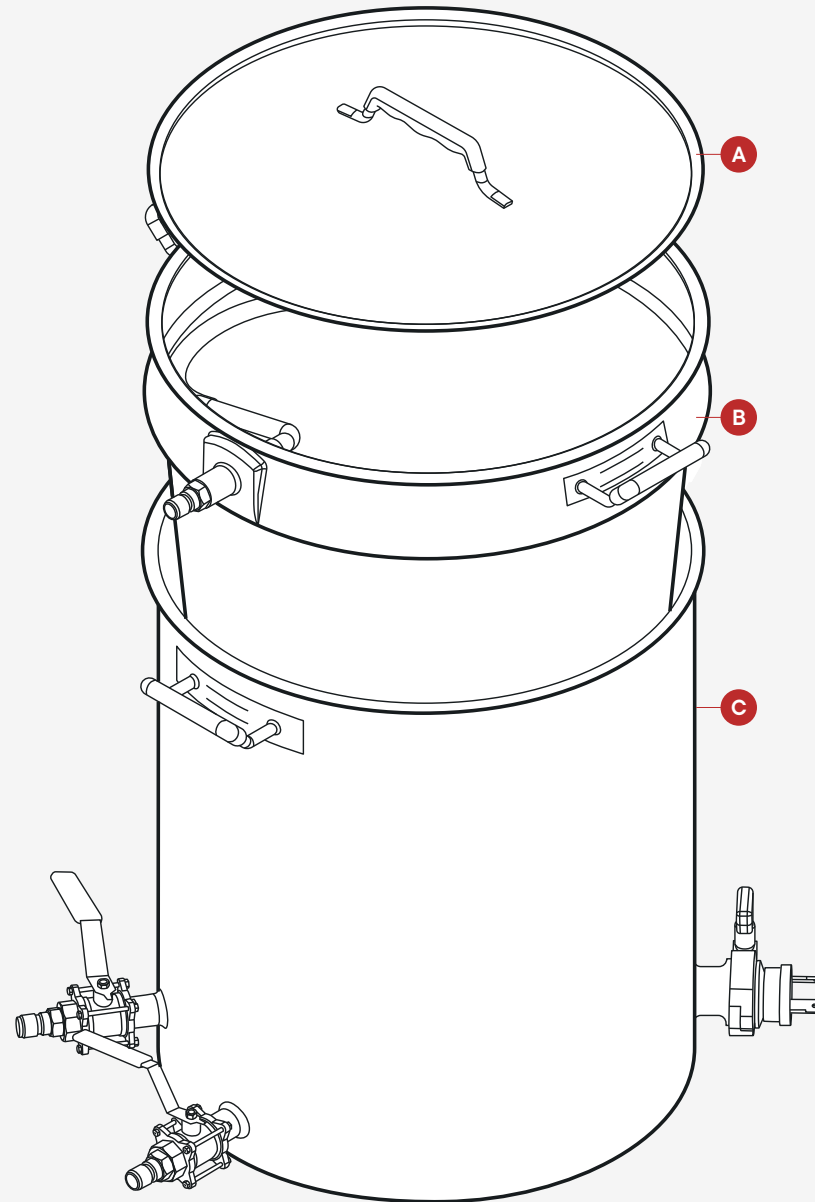
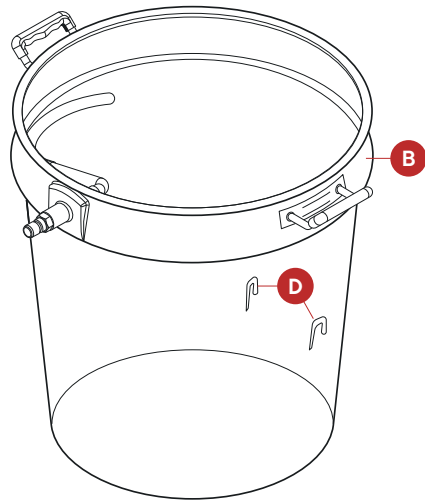

ITEM	DESCRIPTION	QTY
A	Lid	1
B	Basket	1
C	Kettle	1
D	Basket hangers	2

Assembly – Wort Chiller

Our counterflow chiller is made from super-conductive copper, which provides fast chilling speeds. The chiller comes with QC fittings, so you can quickly connect to the rest of your system. It also includes a tee fitting and additional temp sensor so you can monitor the inline chilling temps going into your fermenter.

To get started, attach the temp sensor cable from your kettle to the tee on the chiller. You'll be able to see the chiller exit temp on the control panel and adjust the flow rate to achieve your perfect yeast pitch temp.

If you have high groundwater temps, we recommend submerging your chiller in an ice water bath for the last leg of chilling.

The hot water exiting the counterflow chiller can be saved and reused for cleaning!

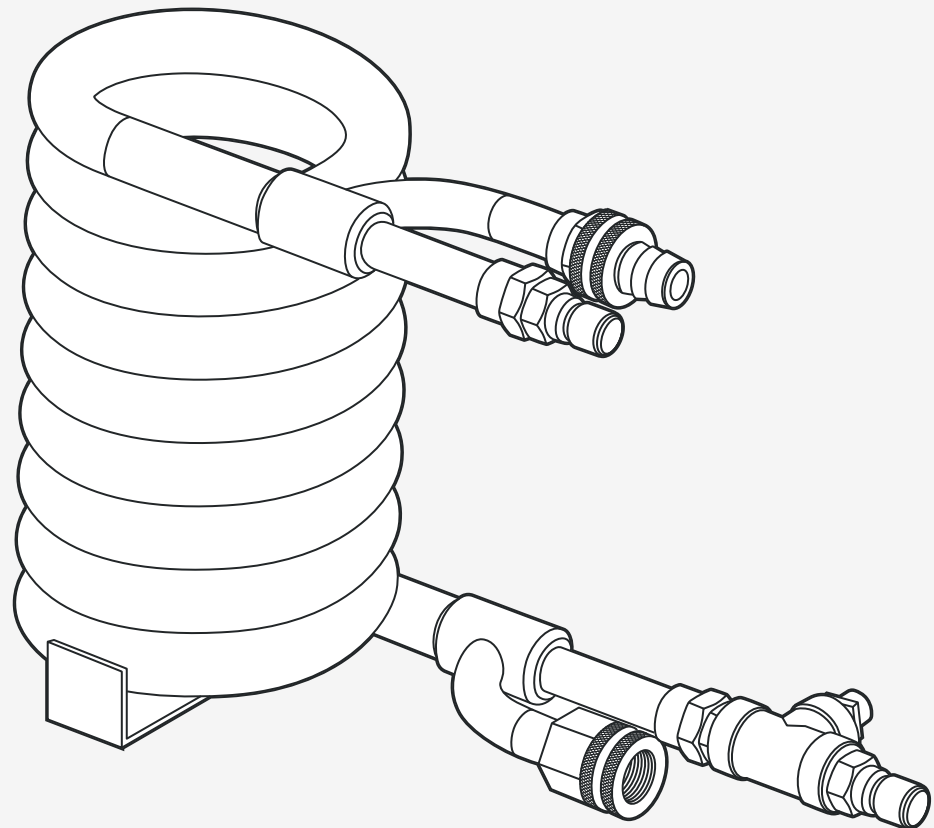

Assembly – Wort Chiller

ITEM	DESCRIPTION	QTY
A	Quick Connect Fitting - MQC x MNPT	2
B	Hose Barb	1
C	Hex Nipple	1
D	T-Fitting	1
E	Temp Sensor	1

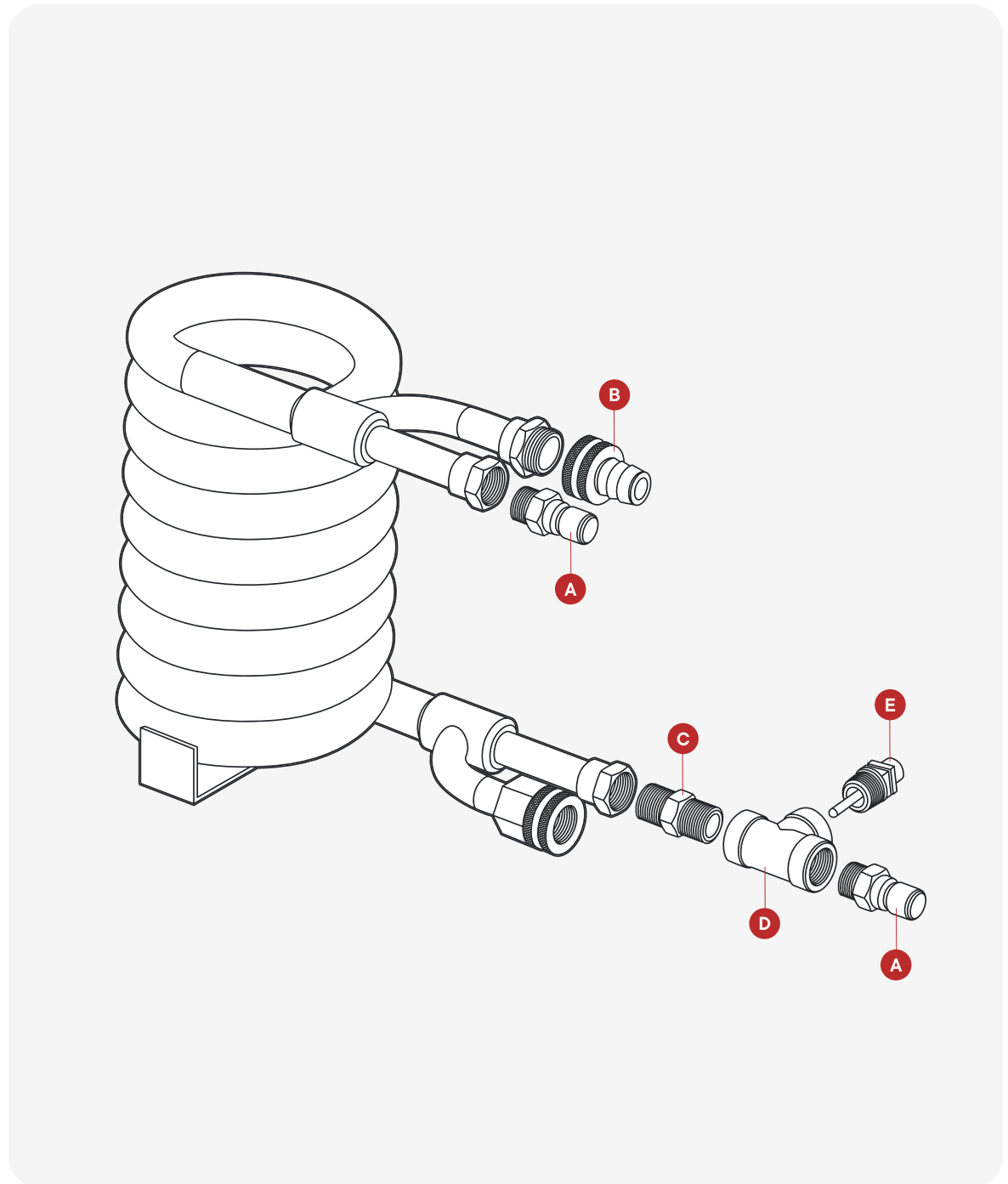

Assembly – Pump

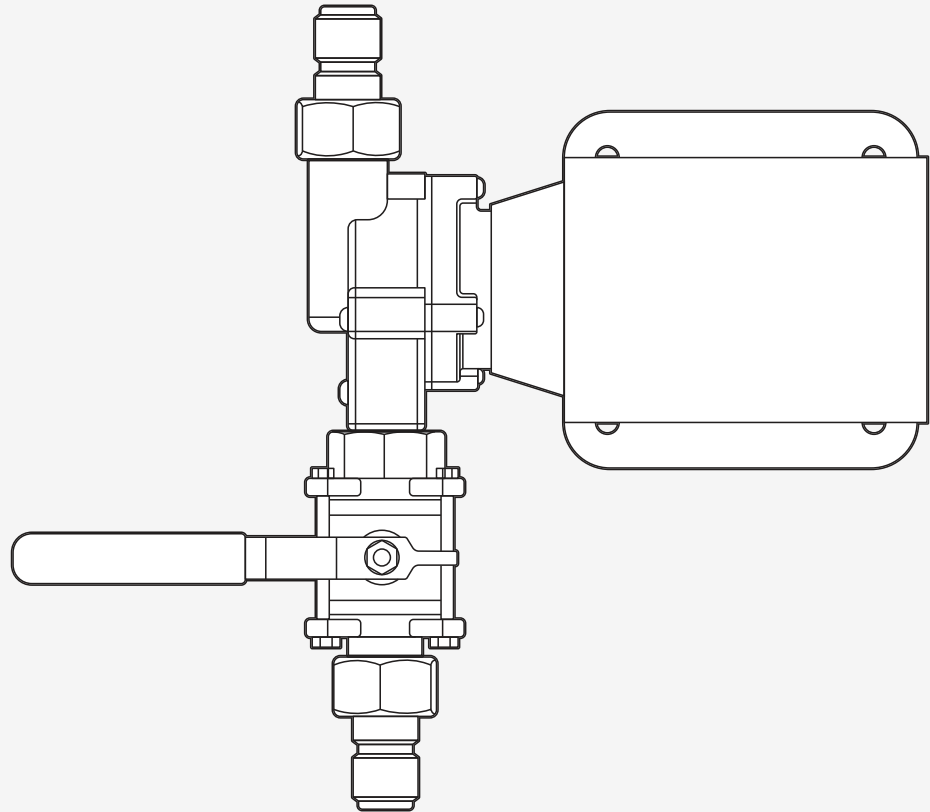

Assembly – Pump

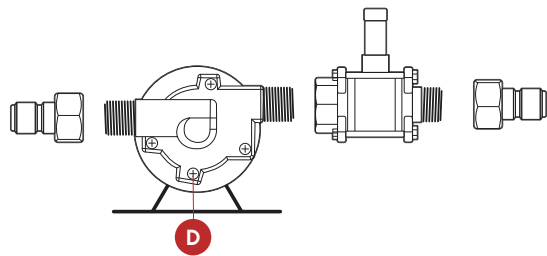

ITEM	DESCRIPTION	QTY
A	Quick Connect Fitting - FNPT x QC Fitting	2
B	Stainless Steel Ball Valve	1
C	Pump	1
D	Pump Head Screws	4

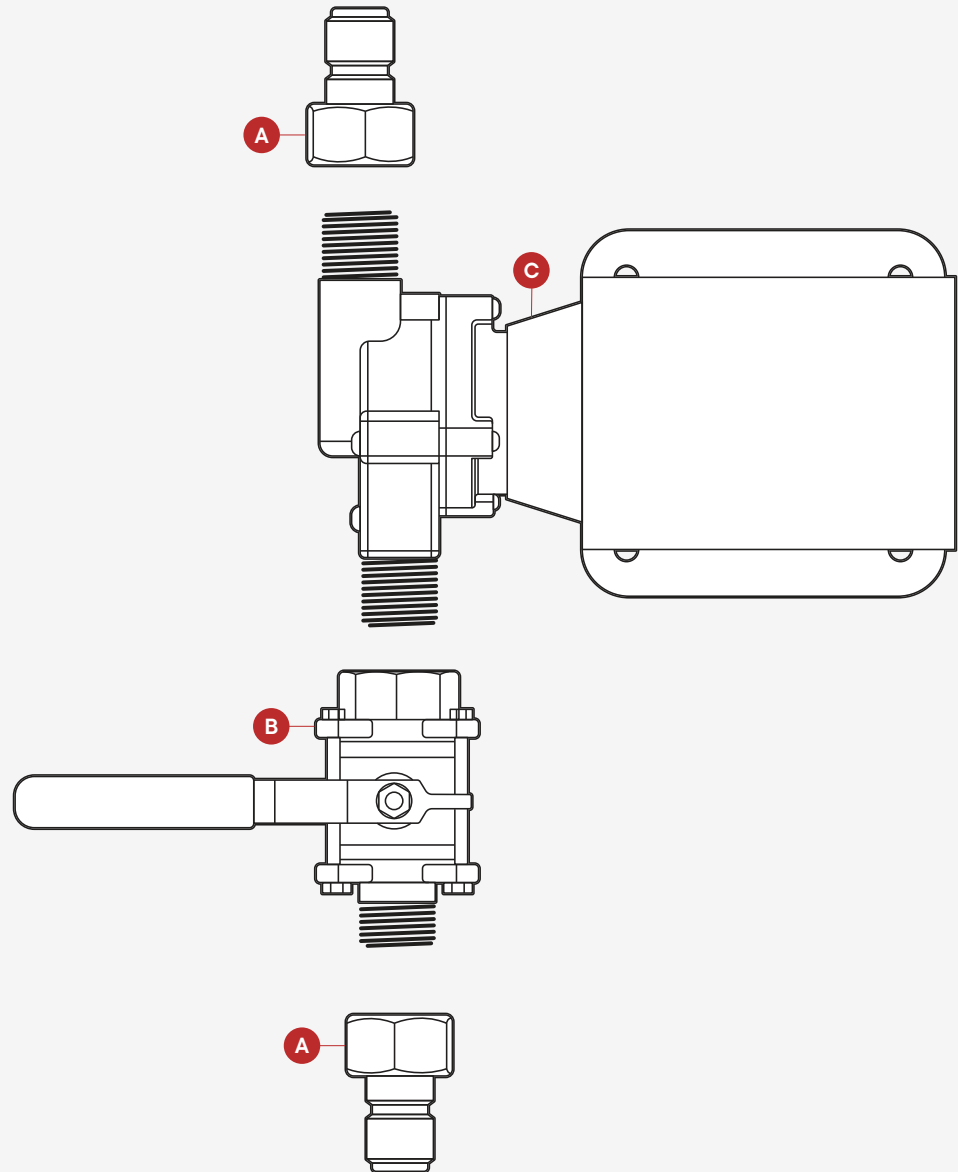

Assembly – Hoses

We use oversized barbs, which creates a secure attachment without the need for sharp hose clamps. The quick connect fittings also use a full port design which doesn't restrict the flow through the fitting resulting in a quicker brew day.

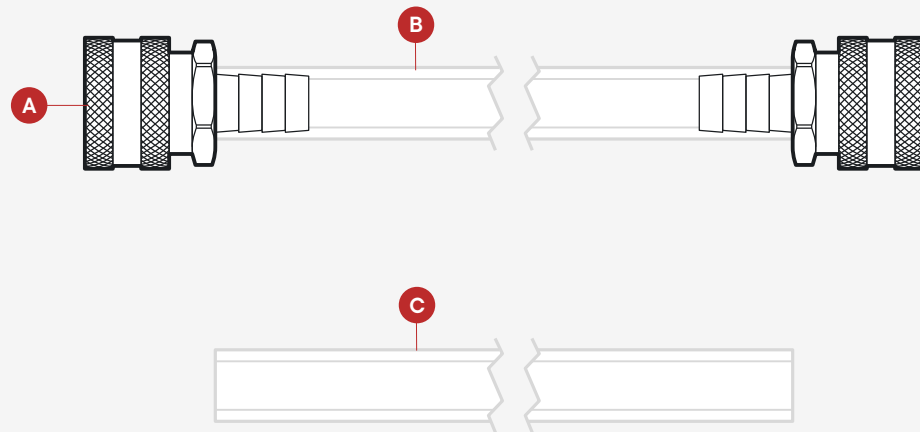

ITEM	DESCRIPTION	QTY
A	FQC x Barb	4
B	Hose - 4'	2
C	Mash Tun Recirculation Hose - 2'	1

Brew Day Guide

Now that your Solo is fully assembled, it's time to get brewing.
Follow the steps in this user guide for a simple and easy Brew Day experience.

Autotune the Control Panel

Heat Strike Water

Mashing

Drain (Lauter)

Boil

Whirl Pool

Chill (Knockout)

Cleaning

Using Your Solo Control Panel

Autotune the Control Panel

Before you get started, make sure to auto-tune your PID controller. This ensures proper system calculations and helps the heating element run as efficiently as possible.

NOTE: you only need to auto-tune your PID before your first brew

1. Fill your kettle 75% full with water.
2. On the PID, press the up arrow until you hit 150 degrees Fahrenheit.
3. Press **set** to lock in the temperature at 150F.
4. Once the PID is close to 150F turn on the pump to recirculate into the basket
5. Once water reaches 150F, press **set** and **<** at the same time.
6. Press **^** three times, then **<** once, then **^** three times to show 0033. Press **set**.
7. This will bring up F00.

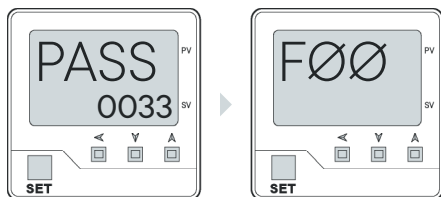

8. Press **^** two times to get F02, and hit **set**.
9. The screen will read AT (Auto Tune) on top with "no" in green at the bottom of the screen.
10. Press **^** to change from "no" to "yes".

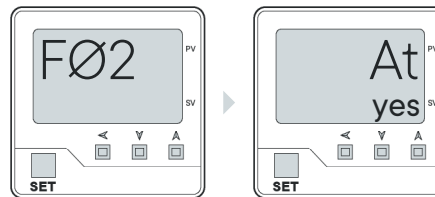

11. Press **set** and **<** at the same time.
12. "ATU" will blink on the bottom left of the screen.
13. Auto Tuning will take about an hour as the PID makes adjustments. Auto Tuning is complete when "ATU" stops blinking!

Controlling Your Boil

Ready to boil? The PID has 2 temperature control options, Auto and Manual. Auto allows you to set a specific temperature, and the heating element will hold the liquid at that temperature. Manual mode will allow us to control heating output by percentage instead of actual temperature. This works similar to dialing your gas burner up or down, but on a numeric scale of 0-100.

We recommend moving your PID to Manual mode while boiling, and keeping it in that mode at all times. To move from Auto to Manual, follow the steps below.

1. Start on the temperature readout screen, and press **set** until you see AMRS.
2. Press up to change from Auto to Manual, and press **set** again.

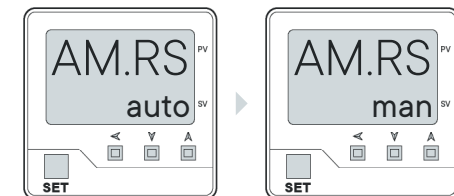

3. Click **set** twice to bring you to the Manual temp screen, and set your temperature.

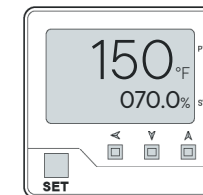

To begin your boil, make sure your elements are completely covered in liquid. We recommend setting the temperature to 100% output until you are at boil, then dial down to 70-80% for the duration of your boil.

Brew Day – Heat Strike Water

During this step you'll heat all the water needed (called strike water) to add your crushed grain which will make your mash. Since this is a single vessel, no sparge system you'll add your entire volume of strike water to your kettle during this step.

Figure 1

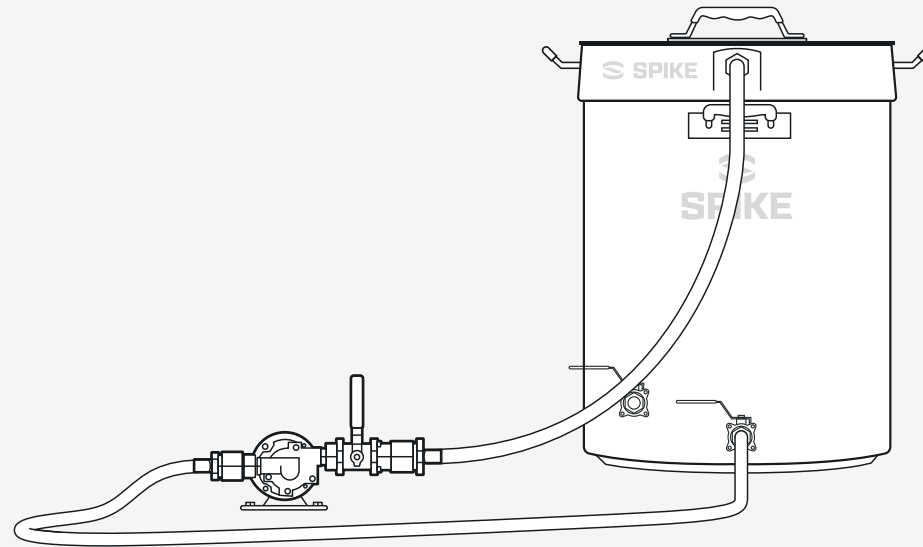

1. Fill your kettle with the entire volume of strike water as prescribed by your recipe. Use the etched volume markers inside the kettle.
2. After filling the kettle with the correct amount of strike water place the basket into the top of the kettle.
3. Connect one hose from the kettle outlet valve to the inlet on the pump.
4. Connect the other hose from the pump outlet to the inlet port on the basket. (see **Figure 1**)
5. Open the kettle drain valve and the pump valve.
6. Set your controller to the desired mash temperature and turn the element on.
7. Turn the pump on and let the kettle heat up until it reaches the desired temp. Put the lid on to help retain heat and speed up heat up times. The constant recirculation from the pump will make sure the temps are consistent throughout the entire kettle and basket.

PRO TIP: Set your controller roughly 3-5 degrees higher than your desired mash temps. Since the grain is colder than mash temps it will lower the temperature inside the kettle/basket once the grain is poured in.

PRO TIP: When priming your pump make sure the pump outlet valve and kettle valves are open so liquid can flow through the pump which will push any air out of pump head. If the pump head has air inside it will not work properly.

Brew Day – Mashing

During this step the crushed grain will be added to the hot water creating a mash. This hot water converts the starches in the grain into sugars. Eventually these sugars will be 'eaten' by the yeast and alcohol will be created.

1. Ensure your hoses are properly set up (see **Figure 2**).
2. Turn the pump off, element off and remove the lid. The lid can conveniently hang on the back kettle handle.
3. Slowly start pouring your crushed grain into the basket. Either have a brew partner stir while you pour the grain in or pour a little at a time and stir in between pours. This stirring will make sure all the grain gets into contact with the strike water and no dough balls are created.
4. Set your controller to your desired mash temps and turn the element on.
5. Turn your pump on and slowly open the ball valve on your pump. Restrict the flow to about ¼ of full flow.

PRO TIP: Always use the ball valve on the pump to restrict the flow. This valve will control the flow most accurately. Never restrict the flow to the pump as it will starve the pump of liquid and can cause premature wear.

Figure 2

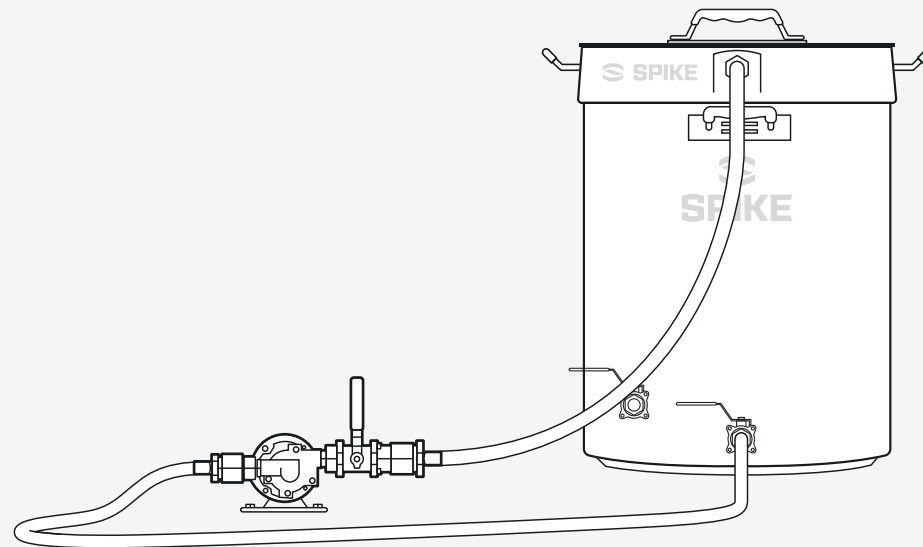

PRO TIP: We recommend a constant recirculation during the entire mash as it helps maintain the most consistent temperatures, as well as helps raise brewing efficiency.

PRO TIP: The volume in the basket should stay at roughly the same height throughout the mash. If the volume starts to increase, there is most likely a stuck mash meaning the filter at the bottom of the basket is clogged with grain. If the liquid level increases, simply turn off the pump, stir the mash for a minute and then turn the pump back on. This should unclog the filter!

PRO TIP: Turn the pump off the last 5mins to let all liquid start draining out of the basket.

PRO TIP: We recommend letting the grain rest for 5-10 minutes to fully hydrate before turning the pump and element on. This will reduce grain pass through and reduce the change of a stuck mash.

Brew Day – Drain (Lauter)

Now it's time to separate the grain from the sugar water that was created (wort). The spent grain can be used for baking, dog treats, fertilizer, etc while the wort will be boiled.

Figure 3

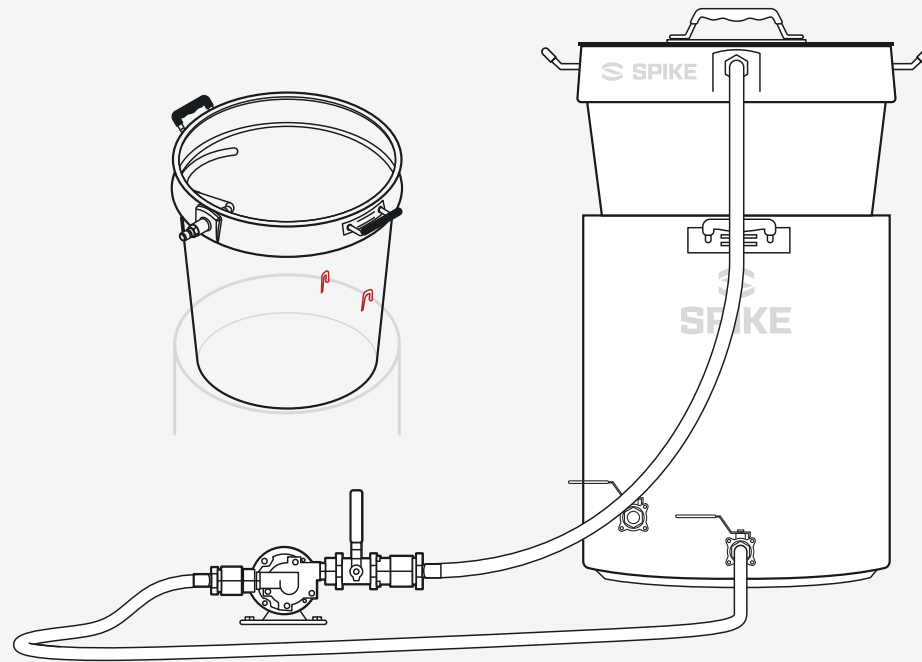

1. Turn the element and pump off.
2. Lift the basket out of the kettle and carefully rest the basket on top of your kettle with both hooks secured over the top lip of the kettle. (see **Figure 3**)

CAUTION: We recommend having two people lift the basket and placing on the kettle for safety reasons.

PRO TIP: With the basket raised out of the wort and hanging from the basket hooks the pump can be turned back on at about ¼ flow. This is called a 'vorlauf' and will help with wort clarity. The grain acts as a filter and recirculating the wort in the kettle back through the grain will allow the clear liquid to flow through while the solids are trapped in the grain bed. We recommend doing a vorlauf for 10 minutes.

3. Let the basket hang on the kettle until it stops dripping wort. This should take 5-10 minutes. However while the basket is draining you can proceed to Step 4 and turn on the element.

Brew Day – Boiling

Follow these steps to keep things rolling during the boiling step. We will boil the wort we just created, which helps evaporate off flavors and concentrate the wort.

1. Close all the valves.
2. Disconnect the hose from the basket inlet valve and attach it to the second port on the kettle. (see **Figure 4**)
3. Set your controller to manual mode, set the output to 100% and turn on the element. (see **Page 16 section: Controlling Your Boil**)

PRO TIP: The controller will be changed from 'auto' mode to 'manual' mode during this step. In auto mode the controller will precisely control the temperature which is beneficial during the mash step. However during the boil step we're more interested in getting a good rolling boil. The controller in manual mode will let you precisely adjust the output to get a good rolling boil.

4. After the basket is done dripping remove it from the kettle.
5. Allow the element to bring the wort to a boil. Once at boil the controller can be dialed back so a steady rolling boil is achieved.

Figure 4

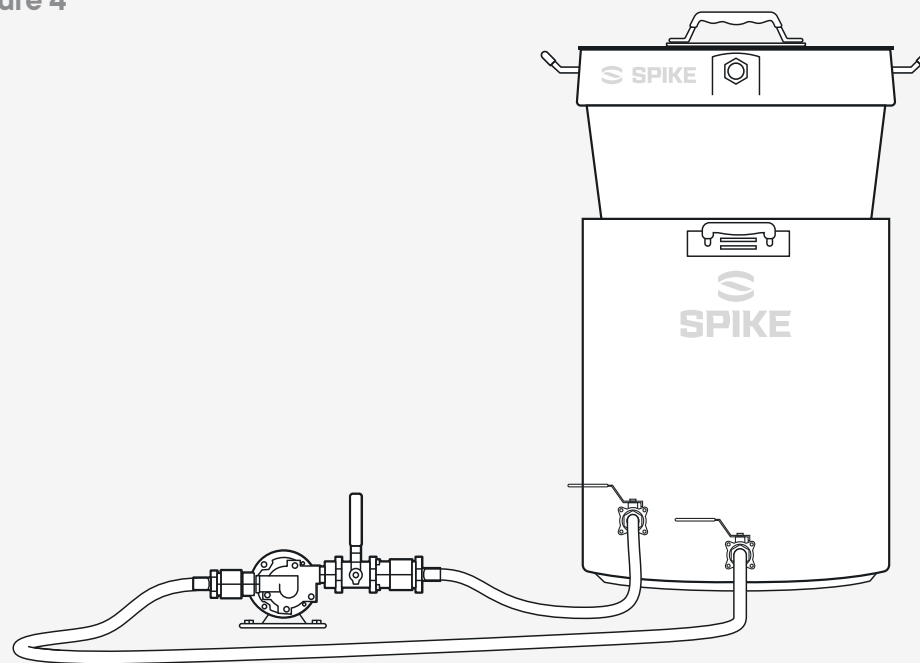

PRO TIP: When wort is about to reach boiling an issue called 'hot break' can occur. The wort can begin to rise and boil over the top of the kettle. This is very similar to boiling pasta. If this starts to happen simply turn the element off and stir the wort. You may need to repeat this a few times but it should subside once your 5 minutes into the boil.

6. Add your hops as needed and boil for the recommended time the recipe calls for.

Brew Day – Whirlpool

Let's take that wort out for a spin. During this step the wort will be run into the pump and back into the kettle at an angle. This will create a "whirlpool" inside the kettle, causing the sediment like grain, hops and proteins to collect at the bottom center of the kettle. This step allows for a clear wort transfer into your fermenter.

1. Turn off the element.
2. Open the outlet valve on the kettle, the valve on the pump and the second valve on the kettle.
3. Turn the pump on.
4. We recommend whirlpooling for 10-15 minutes.
5. Turn the pump off and close all the valves.
6. Allow the kettle to sit for 5 minutes after turning the pump off, so the whirlpool can finish dropping all sediment.

Figure 5

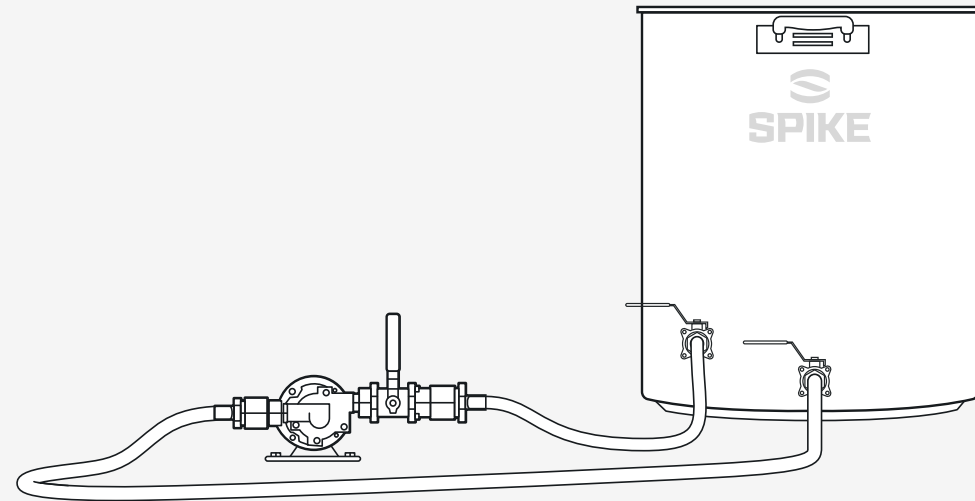

Brew Day – Chill (Knockout)

During this step the wort is cooled down from the near boiling temperatures down to what is called ‘yeast pitching’ temperatures and transferred to a fermenter. This simply means we are cooling the wort down to temperatures where yeast can be added without causing them harm. Typically 70F is a good knockout temp.

1. If you're using our optional counter flow chiller, move the hose from the whirlpool port to the wort inlet port on the chiller.
2. Make sure your chiller and fermenter are sanitized.
3. The cable from the temperature sensor on the kettle can be attached to the temperature sensor on the chiller. This will give the temperature reading of the wort exiting the chiller.
4. Open the outlet valve on the kettle and the valve on the pump so it is just cracked open. When chilling you'll want the flow rate to be very slow.

Figure 6

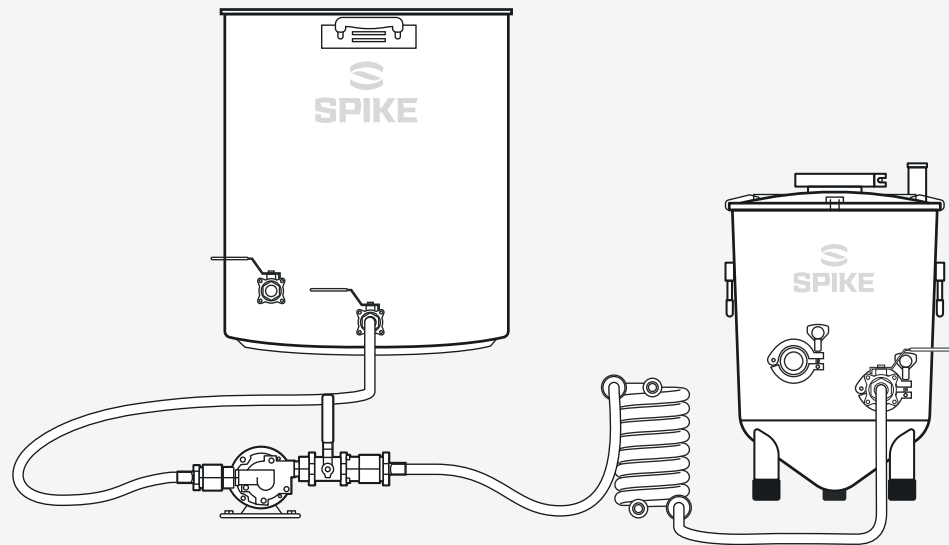

PRO TIP: If you use our optional counterflow wort chiller the outlet water will be roughly 150F which can be collected and used for cleaning your equipment while conserving water.

5. Turn the pump on.
6. Once the kettle has been completely drained into your fermenter close all the valves.

Brew Day – Cleaning

Follow these steps to speed through the cleanup process and keep your equipment running smoothly for your next Brew Day.

Kettle

1. Dump remaining trub and hop material out of your kettle.
2. Rinse the kettle out to remove large particulates.
3. Fill your kettle about 1/4 full with hot water and add your brewery wash.
4. Connect the tubing (see **Figure 7**) and open the valves.
5. Turn the pump on and allow to run for about 5 minutes while you scrub the inside of the kettle clean. This will clean the tubing, pump and hardware internals.

PRO TIP: Open and closing the valves a few times will help clean them more thoroughly.

PRO TIP: Run some of the brewery wash through the baskets inlet to help clean the hardware internals.

Figure 7

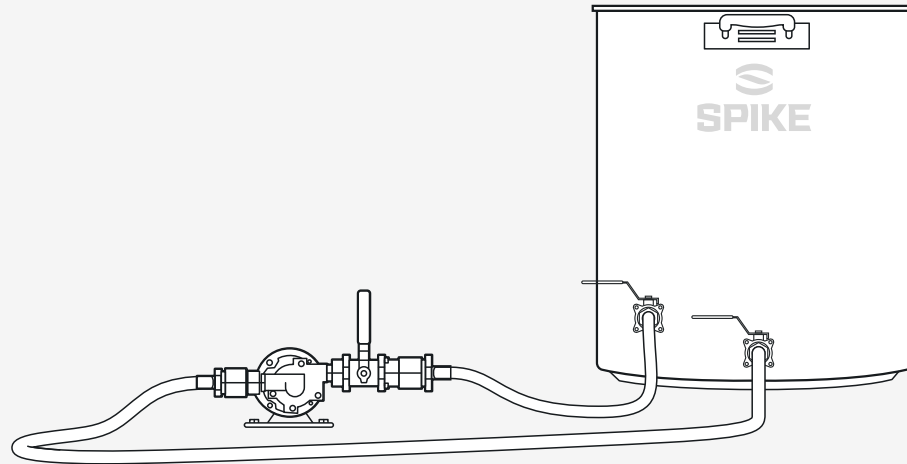

6. Once the kettle and hardware are clean, attach a hose from the pump outlet to the wort chiller outlet, and drain the kettle. This will backflush the chiller and clean it for your next brew day.
7. Repeat the above steps with clean water to rinse the cleaner.

PRO TIP: You can add Star San with your rinse water to rinse and sanitize at the same time.

Basket

1. Scoop or dump grain out of the basket.
2. Rinse the basket off.
3. Scrub the basket clean with brewery wash or dish soap.
4. Rinse the cleaner off the basket.

PRO TIP: Use BKF to shine stainless back up. Avoid logo and volume etchings as they can dull over time.