

# Steam Condensing Lid

User Guide



# Congrats on your new Steam Condensing Lid!

---

Built to transform steam into liquid during the boil, our steam condensing lid will enable you to brew inside without worrying about moisture collecting on your walls and ceiling. These lids are not only designed to fit Spike kettles, but will also work with most other kettle brands on the market.

In this guide we will walk through how to properly set up and use your new lid.

<b>01. Assembly</b> .....	<b>2.</b>
SCL Assembly .....	<b>3.</b>
<b>02. Brew Day Guide</b> .....	<b>5.</b>
Process.....	<b>6.</b>

01.

---

# Assembly

Ready to use your Steam Condensing Lid? This guide will show you how to assemble each piece of equipment with step-by-step instructions and key visuals.

Assembly –  
**Steam  
Condensing  
Lid**

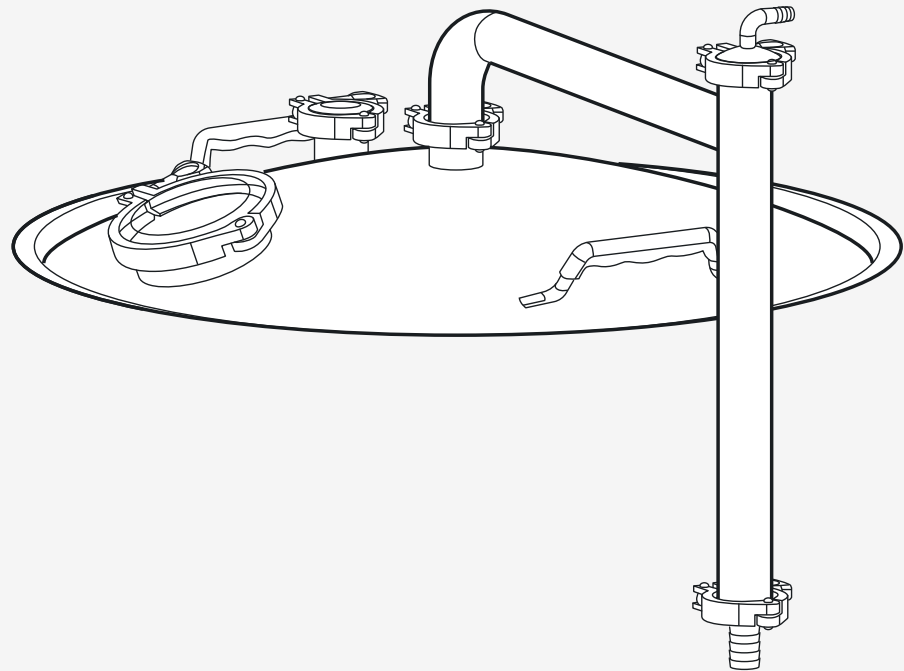

# Assembly – Steam Condensing Lid

ITEM	DESCRIPTION	QTY
A	Condensing Lid	1
B	1.5" TC Clamp	4
C	1.5" TC Gasket	4
D	1.5" TC Cap	1
E	Condenser Piping	1
F	90° Barb	1
G	Condenser Mister	1
H	4" TC Clamp	1
I	4" TC Gasket	1
J	4" TC Clear Cap	1
K	1.5" TC Barb - 3/4"	1
L	Drain Hose	1
M	Supply Hose	1
N	Water Pump	1

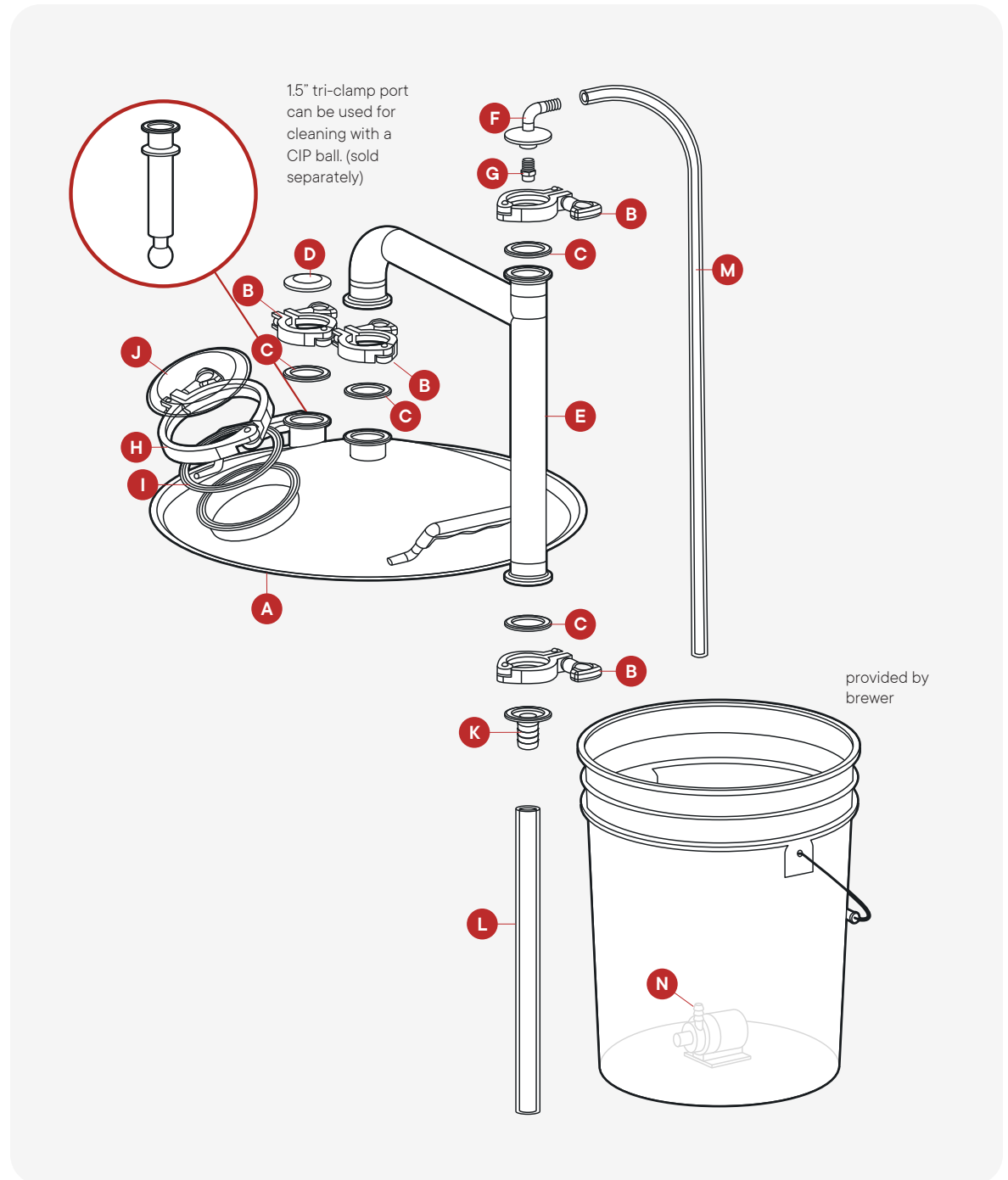

# Brew Day Guide

It's time to put your Steam Condensing Lid to work!

Follow the steps in this user guide for a simple and easy Brew Day experience.

# Brew Day – Process

## Before you start:

Make sure your kettle is on a flat, level surface. If the kettle and lid are not level, the mister liquid can flow back into the kettle. The piping is angled down to prevent this; however, it's engineered to be used on a level surface.

If you are using our equipment profile in Beersmith or Brewfather, we recommend using a boil off rate that is half of what is in the profile.

1. Grab a 5gal or larger container to use for your pump reservoir.
2. Place the submersible pump into the reservoir and stick it to the bottom using the suction feet.
3. When you are getting ready to boil, fill the container up with cold water.

**PRO TIP:** Leave the steam condensing lid off when approaching boil to avoid any boil over. Once the hot break has subsided, you can place the steam condensing lid on.

4. Place the lid on. Whether brewing with electric or gas, you'll need to reduce output as less energy is needed when boiling with the condensing lid on.
5. Run the condensing lid output hose into a floor drain or collection container.

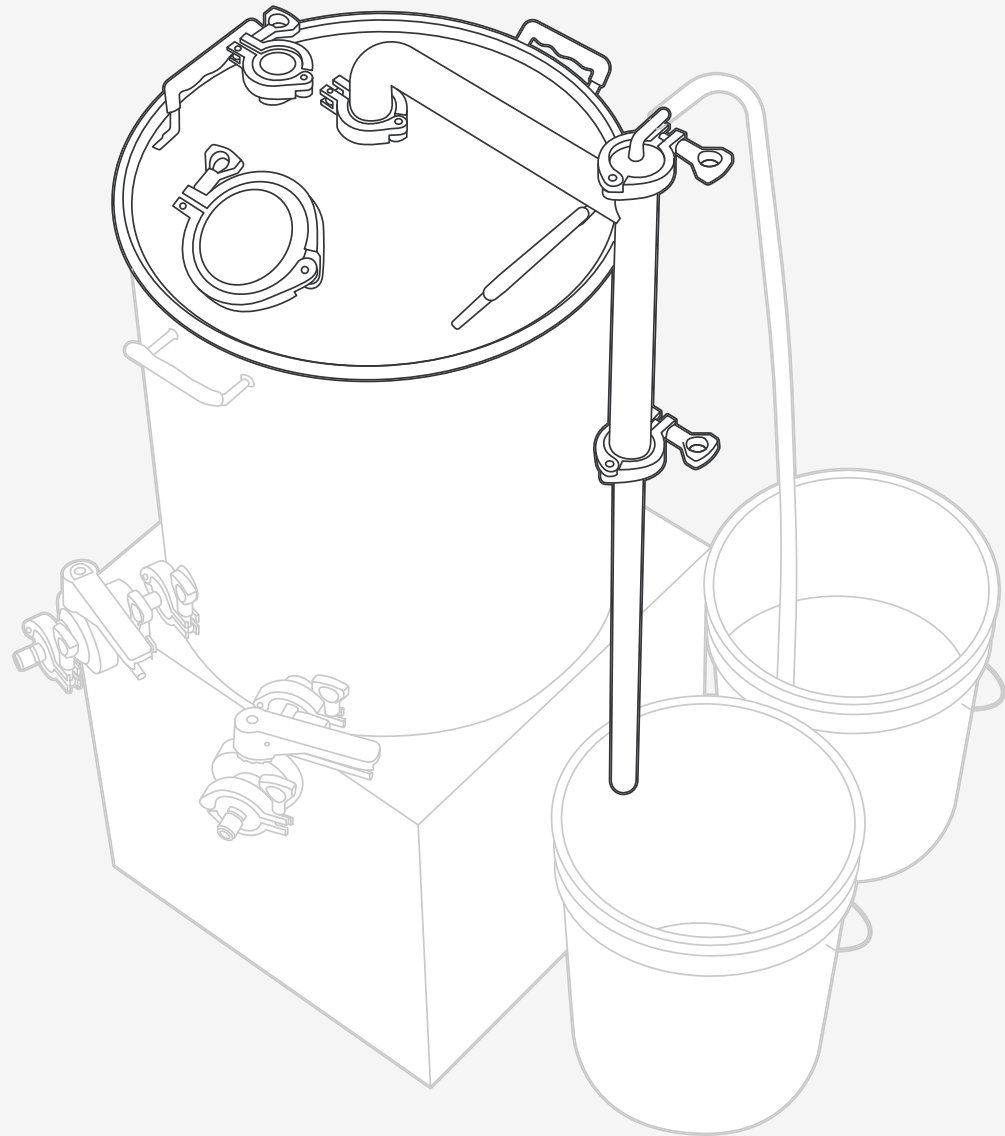

## Brew Day – Process

6. Make sure that the exit hose isn't submerged under water and can drip freely. If it's submerged, back pressure will be created and the steam will take the path of least resistance, which is out through where the lid and kettle meet.

**PRO TIP:** To reduce water usage, the supply water can be recirculated until it reaches about 120F (too hot to hold your hand in). Set that hot water aside for use with cleaning. Do not use for brewing as it contains off flavor compounds.

**PRO TIP:** Ice can be added to your supply bucket at the start of your boil to extend the amount of time the supply water can be used and thus reduce your SCL water usage.

7. Turn on the submersible pump.(Water will begin to flow from the reservoir container, go up through the misting nozzle, and through the top of the condenser piping. This process creates a vacuum by cooling the steam into a liquid. The liquid will then flow out of the bottom of the piping into your collection container.).
8. Boil for the duration of time required by your recipe.
9. Keep an eye on the steam condenser water reservoir so it doesn't run dry. As it empties, refill it with cold water.

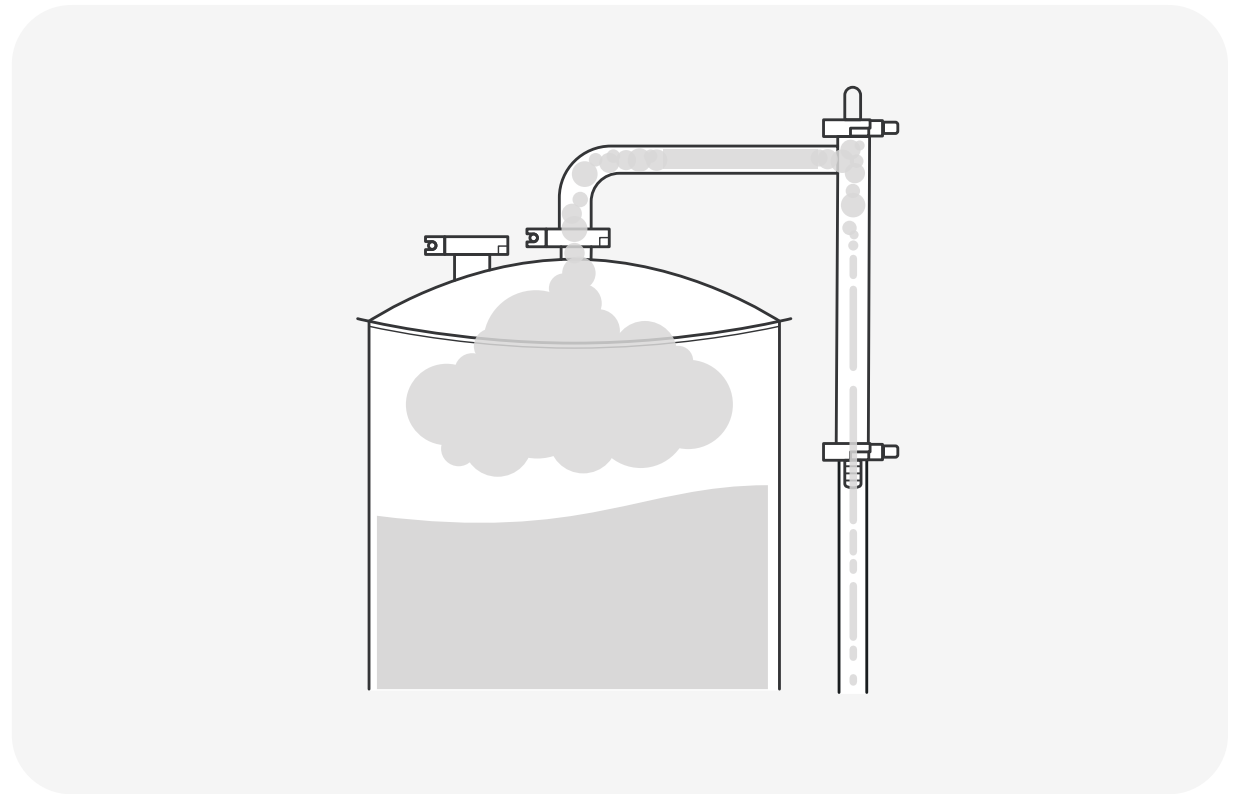

**PRO TIP:** Once your brew day is complete, rinse out the kettle, dump any solids and add a CIP ball to the second 1.5" TC port in the lid to easily wash down your kettle.

**PRO TIP:** When using the CIP Ball with the Spike Steam Condensing Lid, there needs to be an open vent so pressure doesn't build up and cause water to leak from the kettle/lid joint. We recommend leaving the top port open to use as a vent.

**PRO TIP:** People have asked if they can hook up directly to their brewery's water source. Yes, you can; however, you will need to reduce the pressure to 6psi. If not, your flow rate will be too high and you'll consume much more water than needed.