

Nano System

User Guide



Congrats on securing your new Spike Nano System!

We know you're anxious to get brewing, so we made these assembly instructions and Brew Day Guide easy for you to follow and threw in a few pro tips along the way.

Grab a beer, and let's get started.

01. Assembly	2.
Hot Liquor Tank	4.
Mash Tun	6.
Boil Kettle	8.
Steam Condenser Lid	10.
Wort Chiller.....	12.
Pumps	14.
Hoses	16.
Cart Assembly	17.
02. Brew Day Guide	18.
Autotune the Control Panel	19.
Heating HLT.....	20.
Strike Water to MT.....	21.
Mash Control System.....	22.
Vorlauf	24.
Sparging.....	25.
Using the Steam Condenser	26.
Boiling.....	27.
Whirlpool.....	28.
Knockout & Transfer	29.
Cleaning.....	30.

01.

Assembly

Ready to get your Nano up and running? This guide will show you how to assemble each piece of equipment with step-by-step instructions and key visuals.

Hot Liquor Tank

Mash Tun

Boil Kettle

Steam Condenser Lid

Wort Chiller

Pumps

Hoses

Cart Assembly

Assembly –

Before you begin

Make sure the elements are plugged in, and the power cords are fully twisted into position. We also recommend strain relieving the power cords so the full weight is not pulling down on the element connection. Taking these actions will certainly extend the life of your power cords.

Before installing parts into quick-connect (QC) fittings, be sure to lubricate them with water. This will allow them to slide into the QC fitting easily and prevent tearing the o-ring.

Want to mount your control panel on the wall? Attach it to a piece of plywood and affix it to the wall or use a TV mount with the proper weight capacity.

Assembly – Hot Liquor Tank

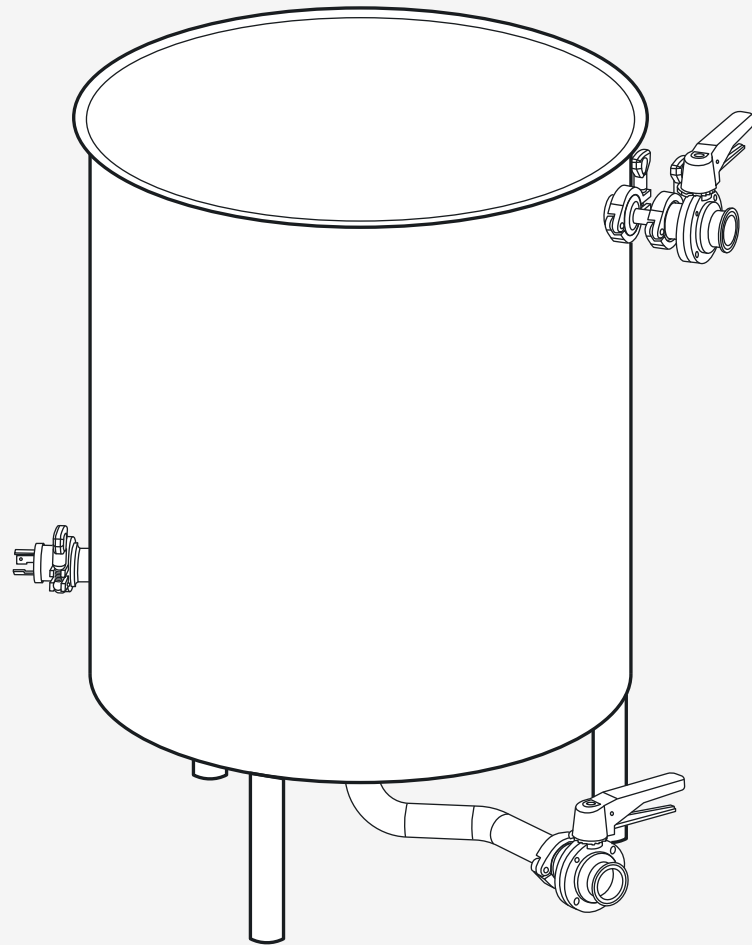

Assembly – Hot Liquor Tank

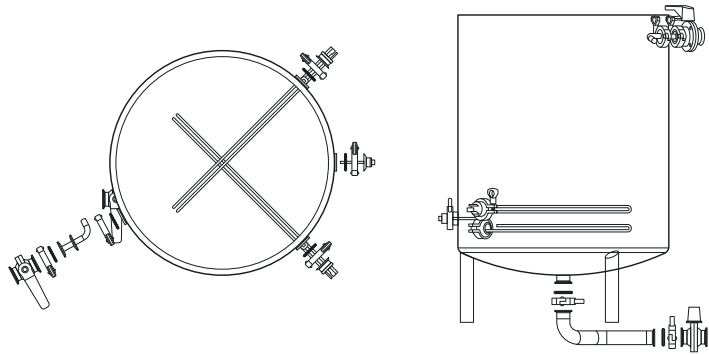

ITEM	DESCRIPTION	QTY
A	Hot Liquor Tank	1
B	Hot Liquor Tank Bottom Drain Piping	1
C	TC Clamp	7
D	TC Gasket	7
E	TC Butterfly Valve	2
F	TC Side Pickup	2
G	6000w Heating Element	2
H	Temp Sensor	1
I	Power Cord - 15' (not pictured)	2

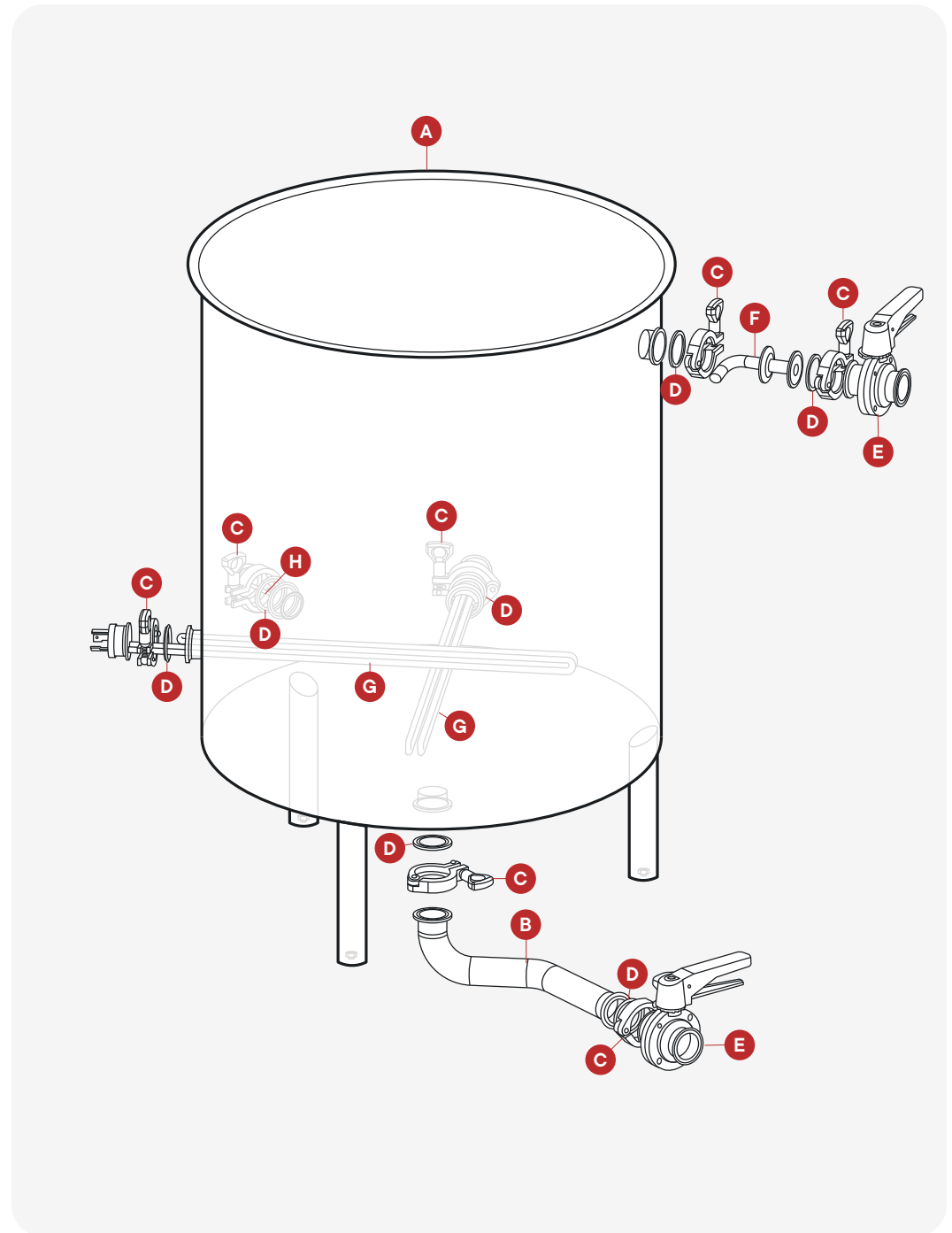

Assembly – Mash Tun

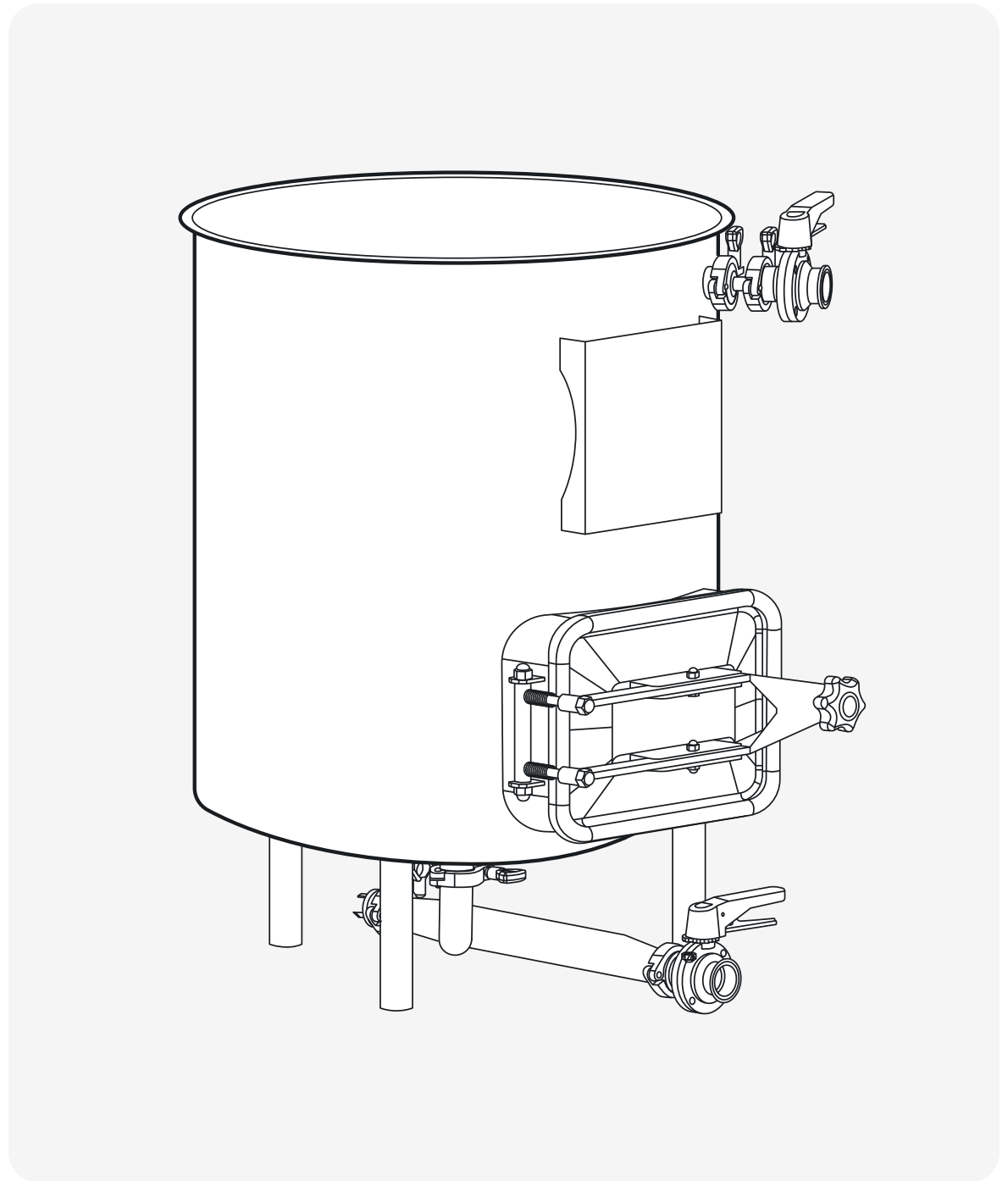

Assembly – Mash Tun

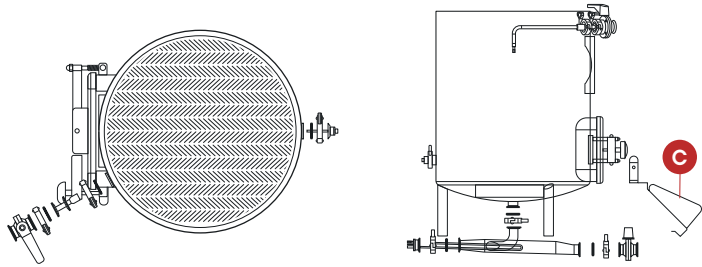

ITEM	DESCRIPTION	QTY
A	Mash Tun Tank	1
B	Manway Door	1
C	Grain chute	1
D	False Bottom	1
E	Mash Tun Bottom Piping	1
F	Mash Tun TC Quick Connect Fitting	2
G	3000w Heating Element	1
H	TC Clamp	6
I	TC Gasket	6
J	TC Butterfly Valve	2
K	Temp Sensor	1
L	Vorlauf Arm	1
M	Sparge Arm	1
N	Power Cord - 10' (Not Pictured)	1

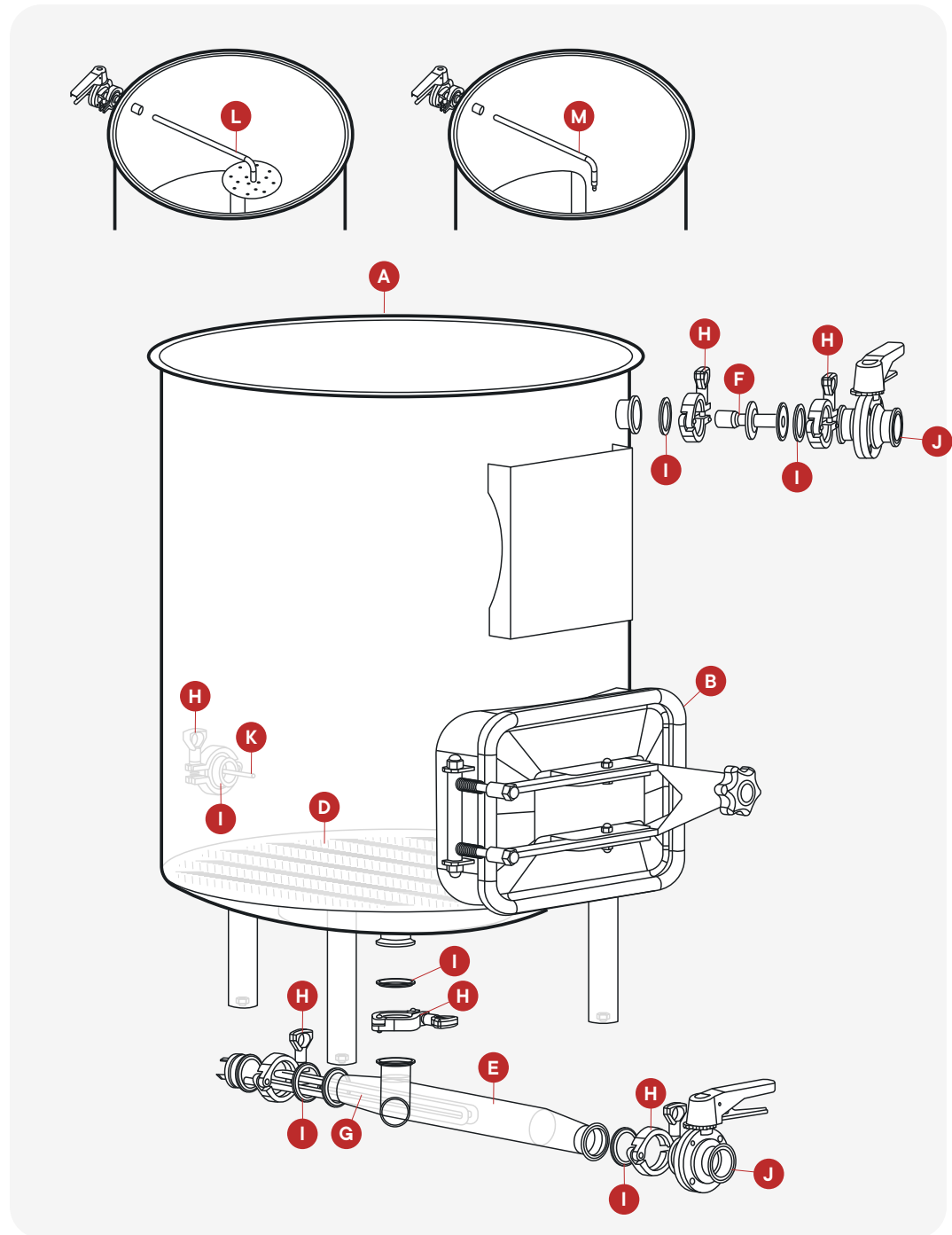

Assembly – Boil Kettle

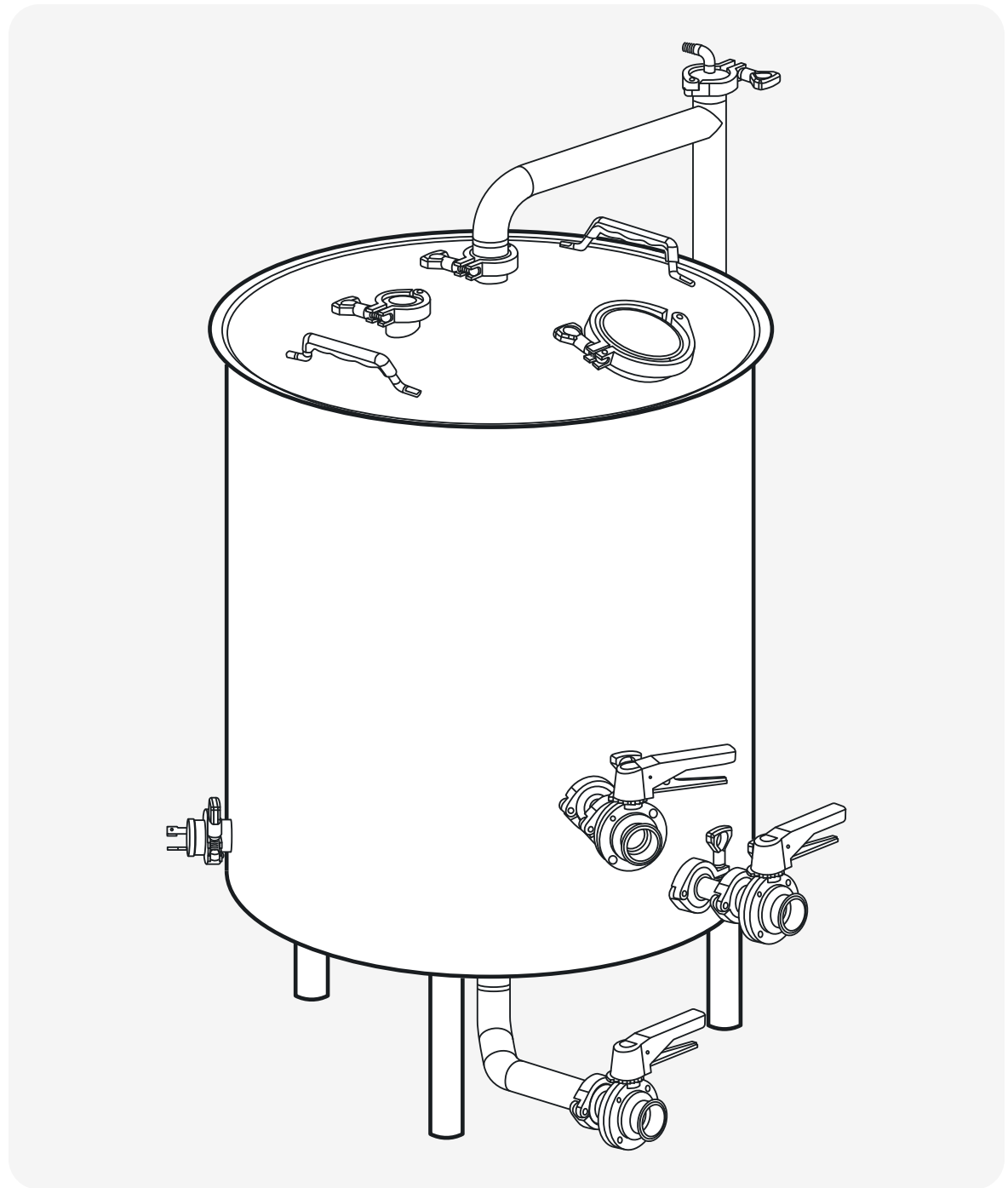

Assembly – Boil Kettle

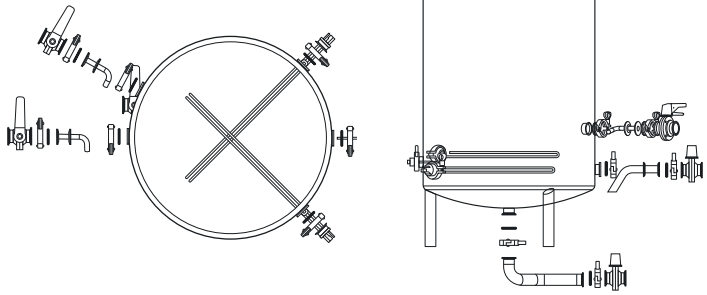

ITEM	DESCRIPTION	QTY
A	Boil Kettle Tank	1
B	TC Clamp	9
C	TC Gasket	9
D	Boil Kettle Bottom Piping	1
E	Butterfly Valve	3
F	1" Boil Kettle Racking Arm	1
G	TC Side Pickup	1
H	6000w Heating Element	2
I	Temp Sensor	1
J	Power Cord - 6' (Not Pictured)	2

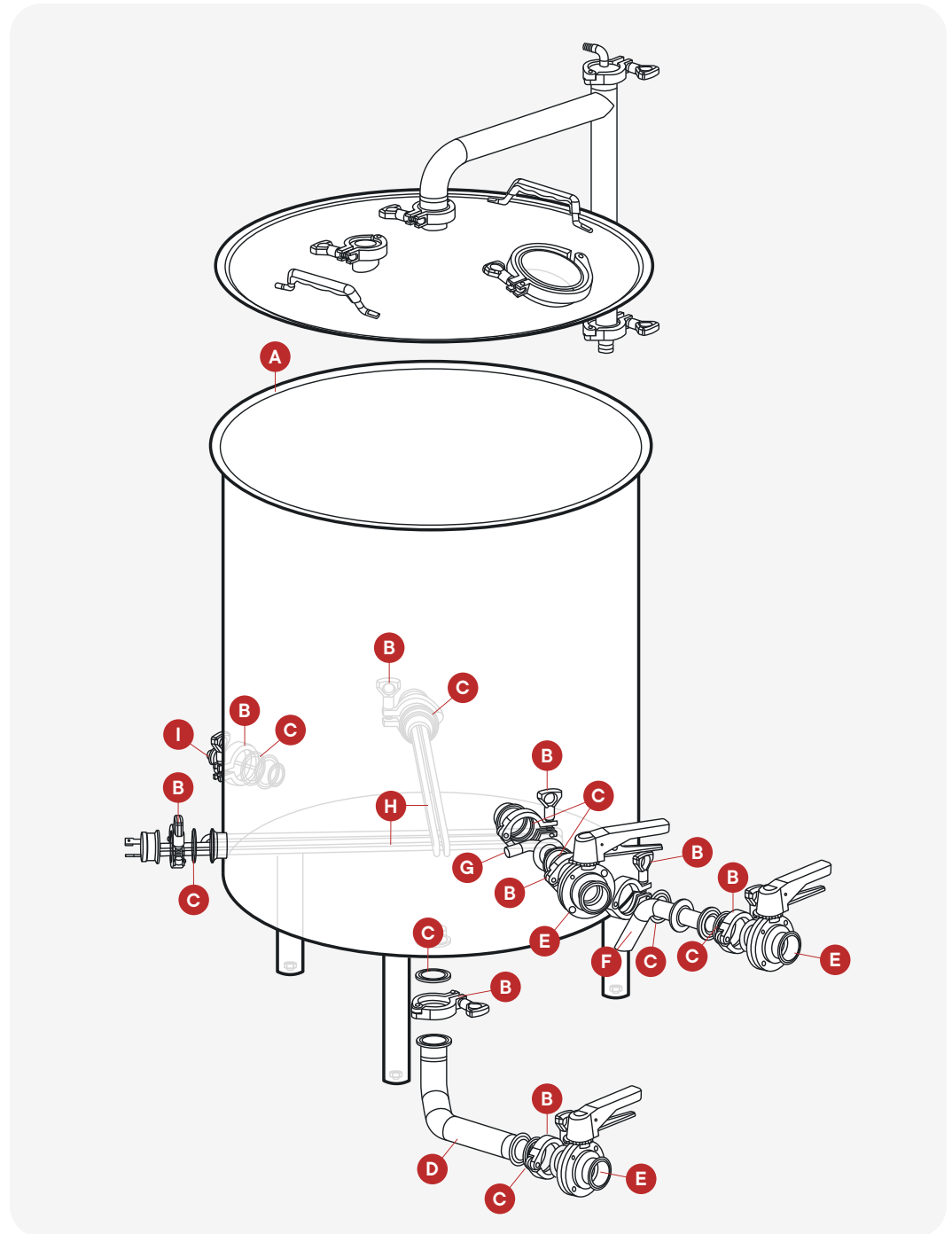

Assembly – Steam Condenser Lid

The Steam Condenser Lid is placed on the Boil Kettle during the boiling step. Follow the process portion of this guide for specific operating instructions.

NOTE:

Make sure you keep the drain hose above the water line if using a bucket for drainage. Failure to do so will cause back pressure and system issues.

NOTE:

Water from drain hose will be warm. This can be collected and used for cleaning or reused for recirculation which cuts down on water usage. The water can be recirculated until it's about 120F or until it becomes too hot to touch. Starting with ice in the drain bucket can increase the amount of time the recirculation water can be used for until it gets too hot.

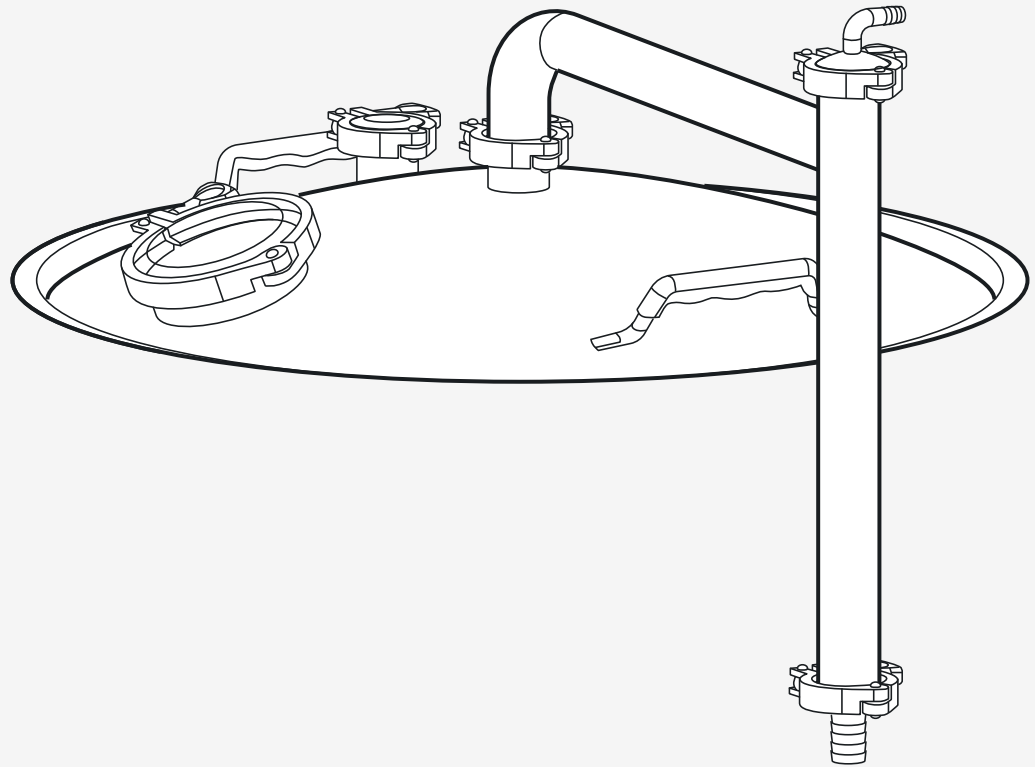

Assembly – Steam Condenser Lid

Wrap the threads of the Condenser Mister (part G) in teflon tape to make a perfect seal.

ITEM	DESCRIPTION	QTY
A	Condenser Lid	1
B	TC Clamp	4
C	TC Gasket	4
D	TC Cap	1
E	Condenser Piping	1
F	90° Barb	1
G	Condenser Mister	1
H	4" TC Clamp	1
I	4" TC Gasket	1
J	4" TC Clear Cap	1
K	1.5" TC Barb - 3/4"	1

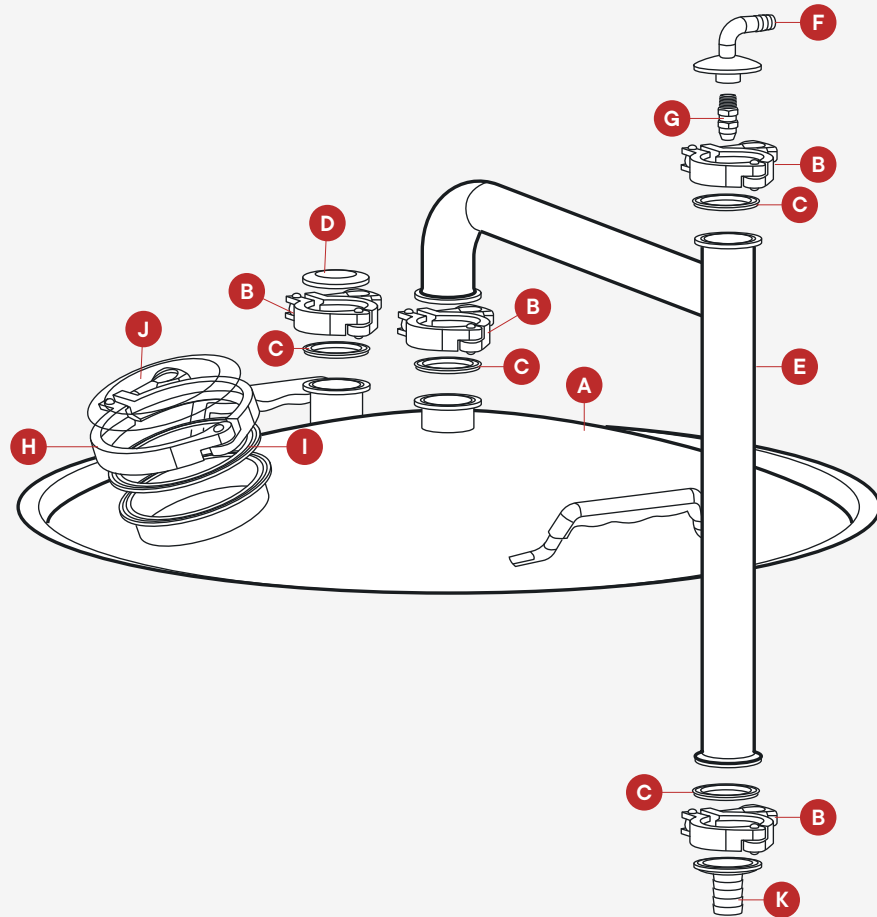

Assembly – Wort Chiller

We designed our own plate chiller to cool the wort as quickly and efficiently as possible. It also has its own dedicated temp sensor. You'll be able to see the chiller exit temp on the control panel and adjust the flow rate to achieve your perfect yeast pitch temp.

NOTE:

Be sure to properly attach hoses to the correct inlet/outlet port. The heat exchanger is a counterflow style so the direction of flow matters.

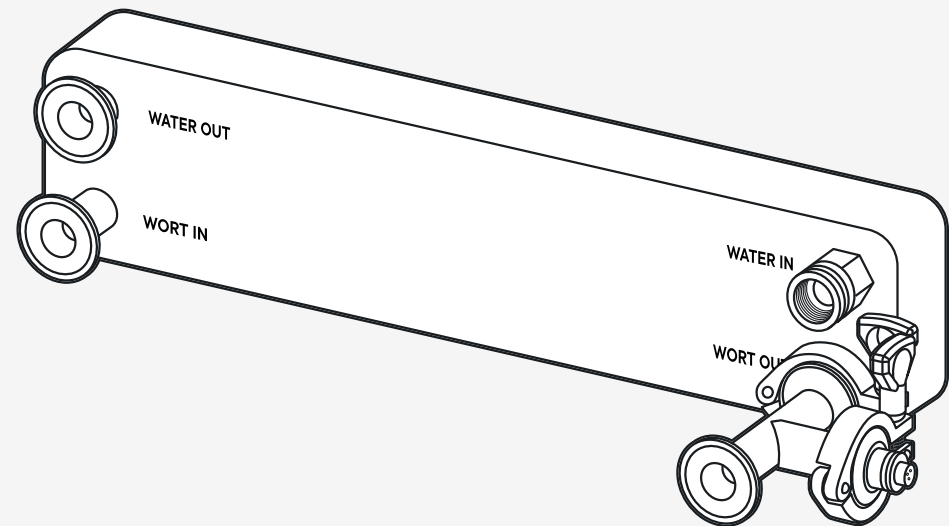

Assembly – Wort Chiller

ITEM	DESCRIPTION	QTY
A	Nano Plate Chiller	1
B	Temp Sensor	1
C	1" TC Tee	1
D	TC Clamp	2
E	TC Gasket	2
F	Mounting Nuts	2

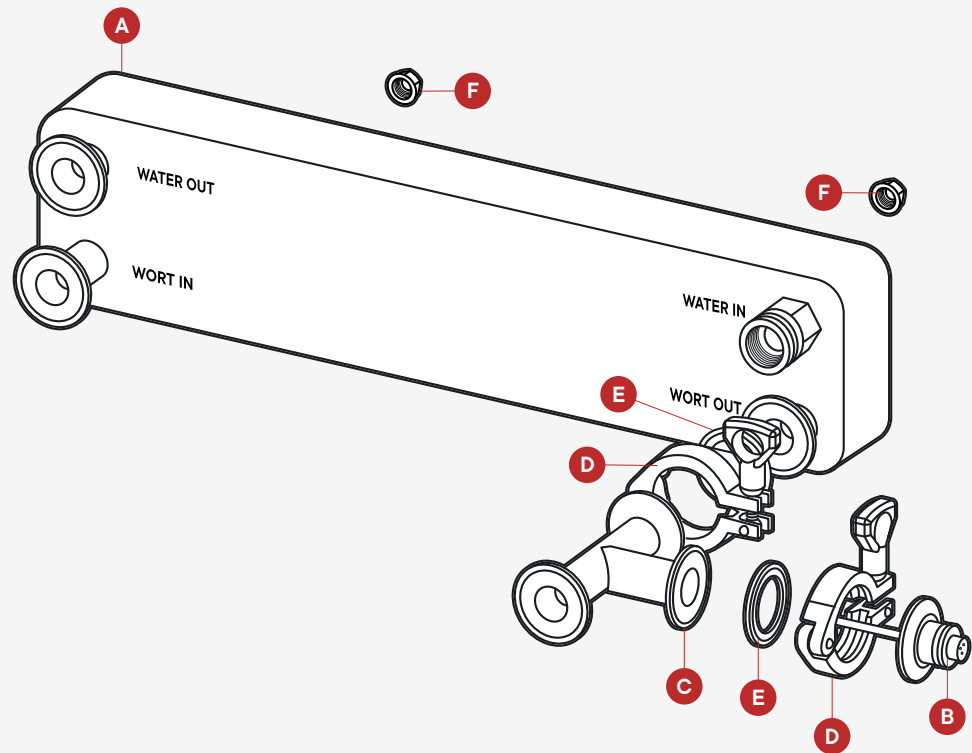

Assembly – Pumps

NOTE:

Assemble the outlet valve and air bleed manifold completely before attaching to the pump head. Since the cross members of the cart are tight to the pump, this will ease with installation.

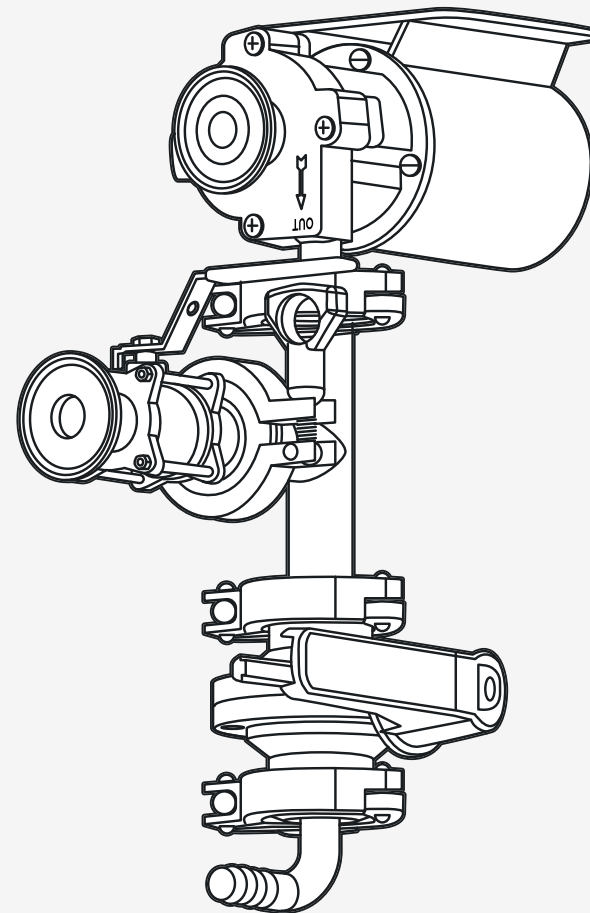

Assembly – Pumps

ITEM	DESCRIPTION	QTY
A	Pump	2
B	TC Clamp	8
C	TC Gasket	8
D	TC Butterfly Valve	2
E	1.5" TC x 5/8" Barb (90°)	2
F	1" TC Tee	2
G	1.5" TC 3pc Valve	2
H	Mounting Nuts (Not Pictured)	8

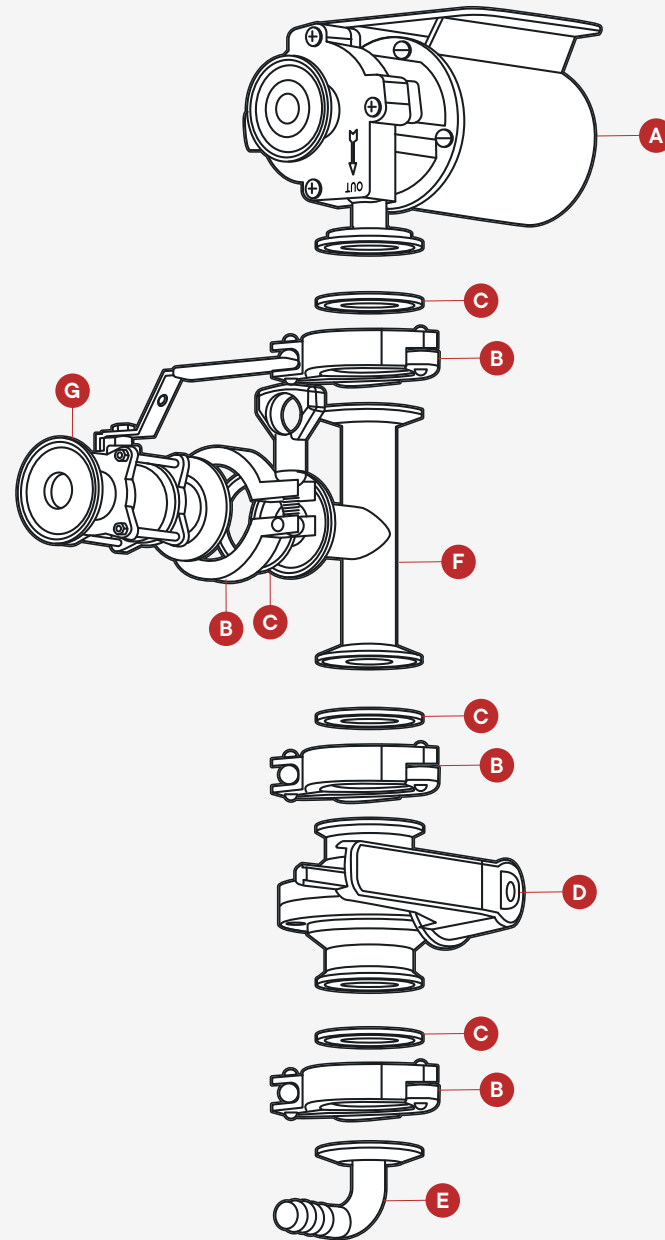

Assembly – Hoses

We use oversized barbs so the silicone tubing will be securely attached without a need for hose clamps. Also, this oversized barb creates a full port which doesn't restrict flow. Depending on the length you cut the hose necessary for the condenser drain, you may have 1' - 3' additional hose.

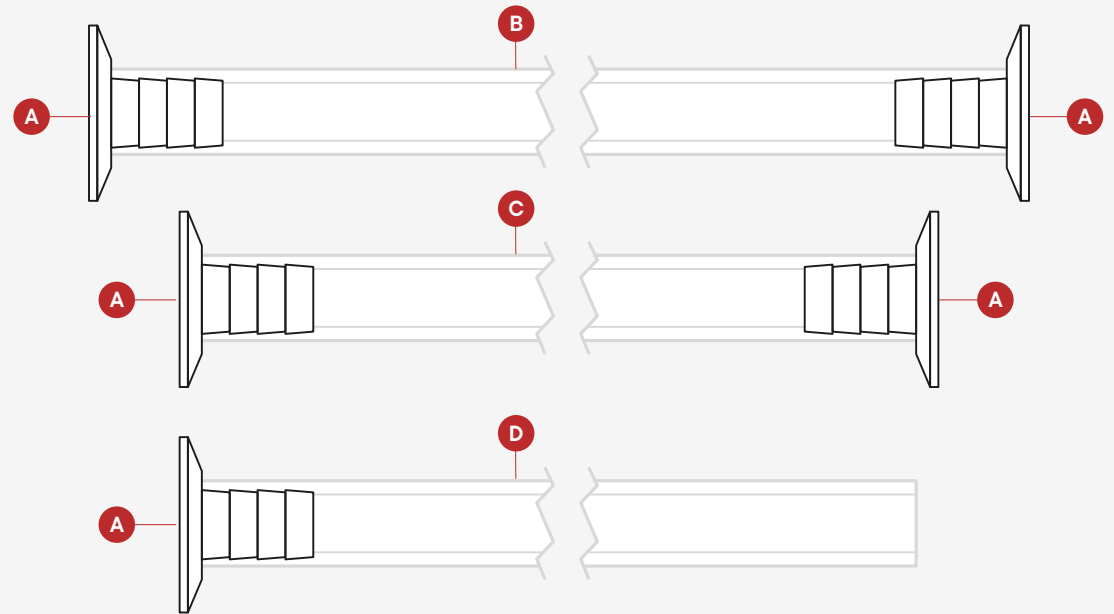

ITEM	DESCRIPTION	QTY
A	1.5" TC Barb - .75"	9
B	Long Hose – 6'	2
C	Short Hose – 4'	2
D	Condenser Exit Hose	1

Assembly – Cart Assembly

To install the casters :

1. Lock the brake on the caster, and then tighten the caster into the cart leg. By locking the brake, it makes the caster its own wrench, and it is easier to screw in the caster.
2. Tighten the caster until the nut makes contact with the cart.
3. The caster has a thread-lock powder so a bit of force needs to be applied to fully install it. Note that by locking the brake, a wrench is not required for the installation.

ITEM	DESCRIPTION	QTY
A	4" Casters	4
B	1.5" Butterfly Valve	1
C	TC Clamp	3
D	TC Gasket	3
E	Condenser Reservoir	-
F	TC Cap	1
G	CIP Ball	1
H	3/8" Vinyl Tubing	1
I	Steam Condenser Pump	1
J	Hose Rack with Bottle Opener	1
K	Lid Holder	1

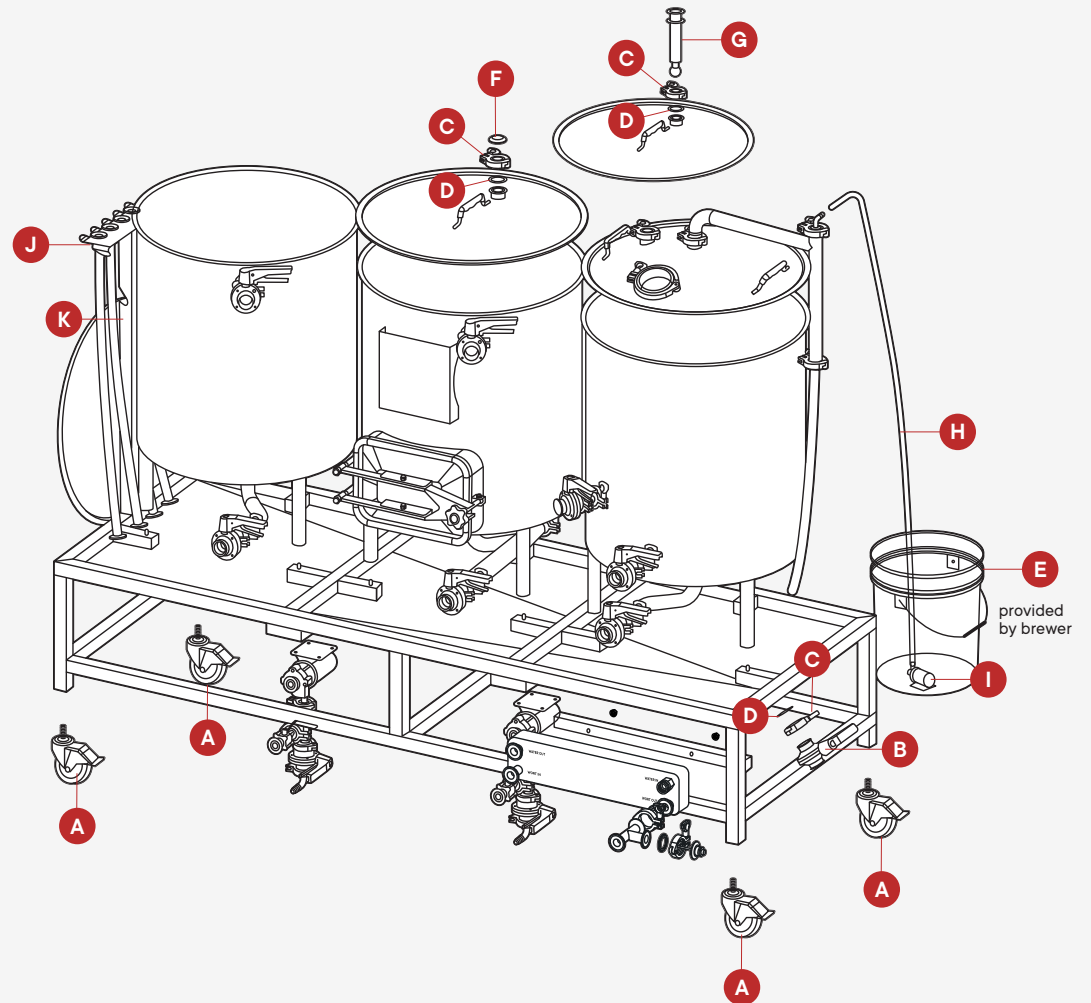

Brew Day Guide

Now that your Nano is fully assembled, it's time to get brewing.
Follow the steps in this user guide for a simple and easy Brew Day experience.

Autotune the Control Panel

Heating HLT

Strike Water to MT

Mash Control System

Vorlauf

Sparging

Using the Steam Condenser

Boiling

Whirlpool

Knockout & Transfer



Cleaning

Using Your Nano Control Panel

Autotune the Control Panel

Before you get started, make sure to auto-tune your HLT and MT PID controller. This ensures proper system calculations and helps the heating element run as efficiently as possible.

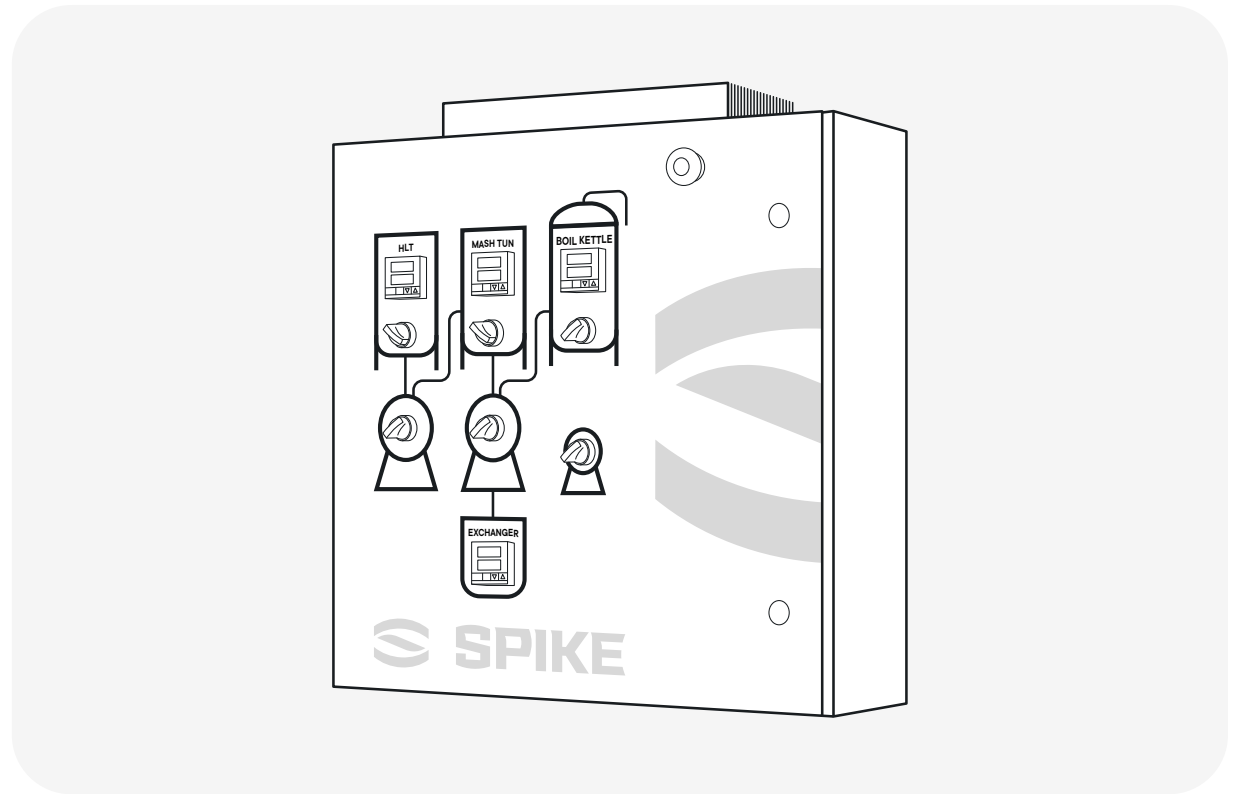

NOTE: you only need to auto-tune your HLT PID before your first brew

1. Fill your HLT 75% full with water.
2. On the PID, press the up arrow until you hit 150 degrees Fahrenheit.
3. Press the  key to set the temperature at 150F.
4. Turn the HLT element switch on to start heating your water to 150F.
5. Once water reaches 150F, press  on the HLT PID until the top line reads "AT."
6. Press the up arrow to turn "AT" to "on" and press . This will start the Auto Tune process.
7. Auto Tuning will take about an hour as the PID makes adjustments. Auto Tune is complete when **AT** stops blinking on your PID.



Controlling Your Boil

The BK PID is based on % power output to fine tune a rolling boil. This is opposed to the temperature control like the HLT and MT.

1. Once the elements are submerged the BK can be set to 100% and turned on. Press  3 times until you see "OUT".
2. Use the **Up** and **Down** arrows to change the % power output and press  to set the output. Press  again to see the temperature readout screen.

3. To begin your boil, we recommend setting the temperature to 100% output to get the boil started. When the BK is nearing boil, be sure to watch out for hot break and boil overs.
4. Once the hot break has passed you can cover the BK with the steam condenser lid and reduce the BK PID to roughly 40-50% output.

Brew Day – Heating HLT

Figure 1

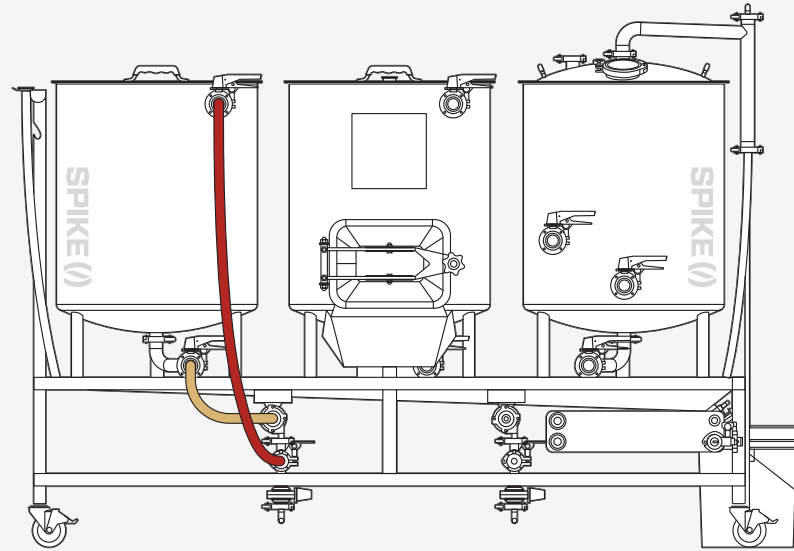

1. Fill HLT with 45 gallons of water.
2. Connect a short hose (**Gold**) from bottom of HLT to water pump inlet. (see **Figure 1**)
3. Connect a long hose (**Red**) from pump outlet to top of HLT. (see **Figure 1**)
4. Purge the pump and input hose (**Red**) of air. To purge the pump, with the HLT drain valve open, open the air bleed valve on the pump until a solid liquid stream flows. Close the valve - your pump is now purged of air.
5. Turn on the water pump to recirculate the HLT to keep a consistent temp throughout.
6. Set HLT to 2 degrees above your strike temp.

PRO TIP: The HLT takes roughly 60-75 mins to heat to strike temps. Heat your HLT the night before for a shorter heat up time on brew day

Brew Day – Move Strike Water to MT

Figure 2

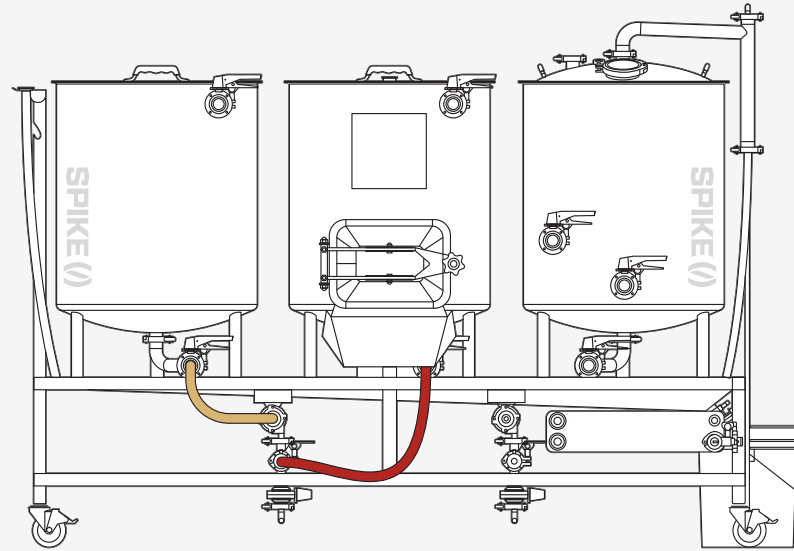

1. Move the long hose (**Red**) from the top of the HLT to the bottom of the MT. (see **Figure 2**)
2. Transfer enough strike water to your mash tun. If your strike water is too hot you can add cold water. If your strike water is too cold use the Mash Control System (discussed in 'Recirculating the Mash' step on page 25) heater to heat to desired strike temp.
3. When you reach your desired strike temp, turn off the pump and add the grain.
4. Stir the grain for a few minutes to remove any dough balls (dry grains).
5. Let the wort rest for 10-15 minutes.

Brew Day – Mash Control System (MCS)

Figure 3

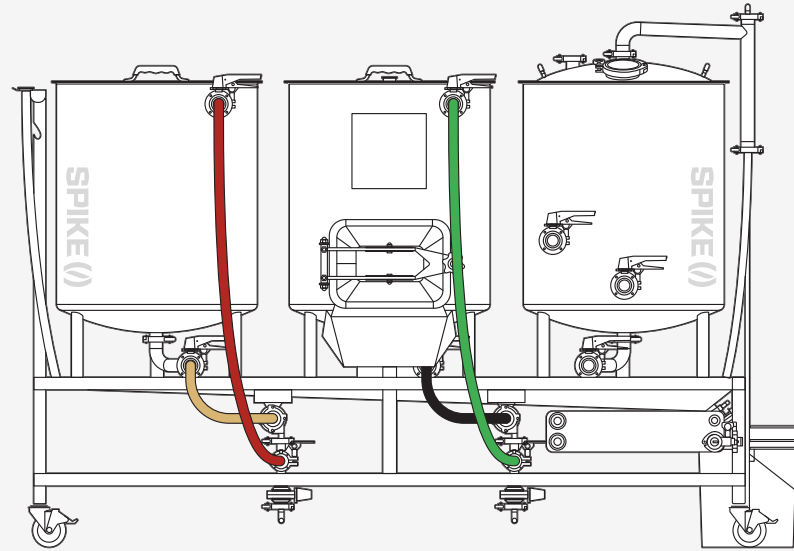

1. Add a short hose (**Black**) from the bottom port of the MT to wort pump inlet. (see **Figure 3**)
2. Add a long hose (**Green**) from the wort pump outlet to the top port of the MT. (see **Figure 3**)
3. The MT temp will be controlled by the Mash Tun PID and MCS.

NOTE: The MCS element and pump are interlocked to prevent accidental scorching/dry firing. The element can not be turned on unless the pump is running. Also double check all valves in the pump circuit are open before turning on the MCS element

There are 4 different ways the Spike Nano can be used to mash:

1. Single Infusion – Mash Element: Off Wort Pump: Off
 - After mashing in, place the lid on the MT and let the mash rest for the entire mash duration
 - Set the mash element to 'OFF' and the wort pump to 'OFF'
2. Auto Mash – Mash Element: On Wort Pump: Auto Mash
 - After mashing in, install the vorlauf arm into the top quick connect fitting and place the lid on the MT
 - Set the mash tun PID to your desired mash temp
 - Set the mash element to 'ON' and the wort pump to

'AUTO MASH'

- In this setting the pump and element will turn on once the mash tun drops below 1F of your desired temp
3. Recirculated Mash – Mash Element: On Wort Pump: On
 - After mashing in, install the vorlauf arm into the top quick connect fitting and place the lid on the MT
 - Set the mash tun PID to your desired mash temp

Continued on next page.

Brew Day – Mash Control System (MCS)

Figure 3

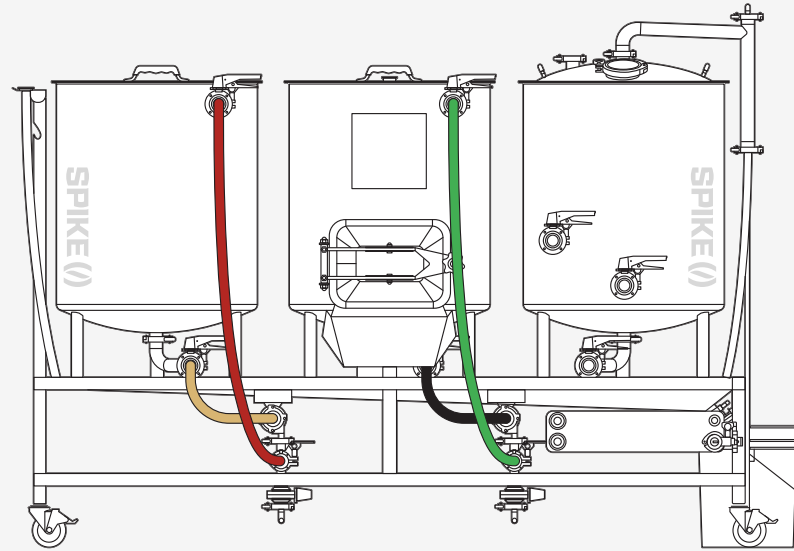

- Set the mash element to 'ON' and the wort pump to 'ON'
- The pump will remain on during the entire mash. The element will keep the mash at the desired temp

PRO TIP: If you use this technique the vorlauf step can be skipped as a vorlauf was performed during the entire mash step.

4. Step Mash – Mash Element: On Wort Pump: Auto Mash

- After mashing in, install the vorlauf arm into the top quick connect fitting and place the lid on the MT
- Set the mash tun PID to your desired mash temp
- Set the mash element to 'ON' and the wort pump to 'AUTO MASH'
- After each mash step is completed increase the mash tun PID to the next desired mash temp

PRO TIP: Ramp speed is roughly .75 F/min.

PRO TIP: We recommend a slow trickle over the grain bed when recirculating. Use the ball valve to slow flow as a ball valve gives more precise control than a butterfly valve. Never restrict flow to the inlet of the pump - only on the outlet.

PRO TIP: Use the mash period to refill the HLT and bring the water up to the desired temperature for sparging. The excess water can be used for double batching or cleaning.

Brew Day – Vorlauf

When the mash is completed, it is time to “vorlauf” or recirculate the mash. This process moves small particles from the bottom of your grain bed to the top, preventing them from getting into the boil kettle and the finished beer.

1. Leave your hoses in the same configuration as the Mash Control System step.
2. Install the vorlauf arm into the quick connect fitting on the top port of the MT. (see **Figure 4**) Be sure to wet the fitting first to ease installation.
3. Vorlauf for ~15min or until the wort runs clear

Figure 4

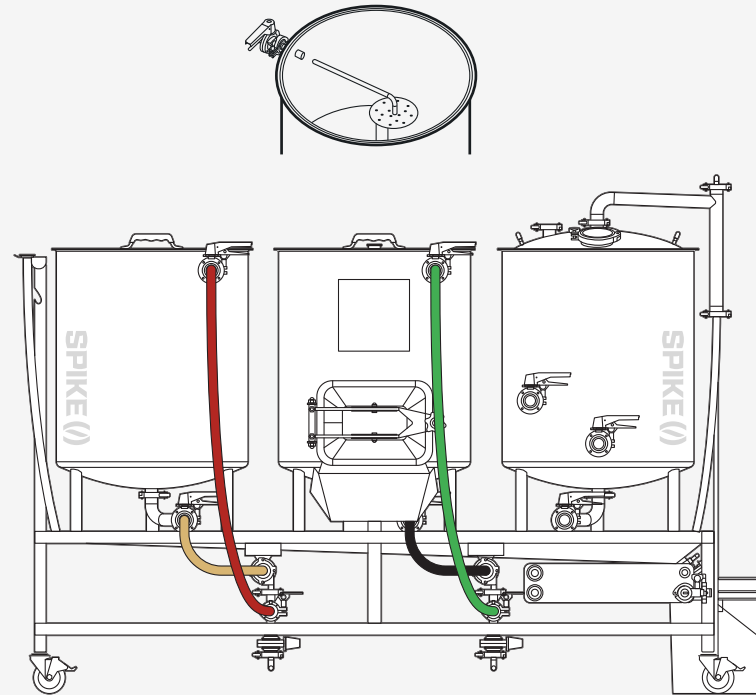

Brew Day – Sparging

Figure 5

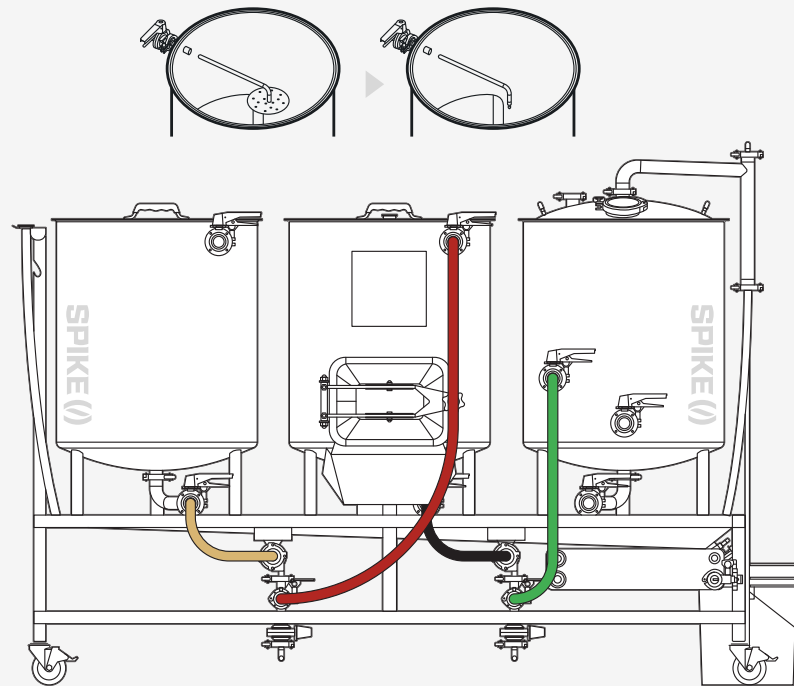

1. Move the long hose (**Red**) from the top of the HLT to the top of the MT. (see **Figure 5**)
2. Move the other long hose (**Green**) from the top of the MT to the top port on the BK. (see **Figure 5**) The green hose will stay in this position for the Whirlpool later.
3. Remove the vorlauf arm and install the sparge arm. (see **Figure 5**)
4. Open both the water and wort pump outlet ball valves about $\frac{1}{4}$ of the way.
5. Turn on the water pump and wort pump.
6. Adjust the valve on the wort pump so a slow trickle of water is flowing into the BK.
7. The flow into the MT and into the BK should match.
8. Sparge the desired amount and fill the BK until you reach your pre-boil target volume.

PRO TIP: Once the wort in the BK covers the elements they can be turned on. (see next step)

Brew Day – Using the Steam Condenser Lid

Built to transform steam into liquid during the boiling process, our steam condenser lid not only reduces your boil-off rate, it allows you to brew inside without worrying about moisture collecting on your walls or ceiling.

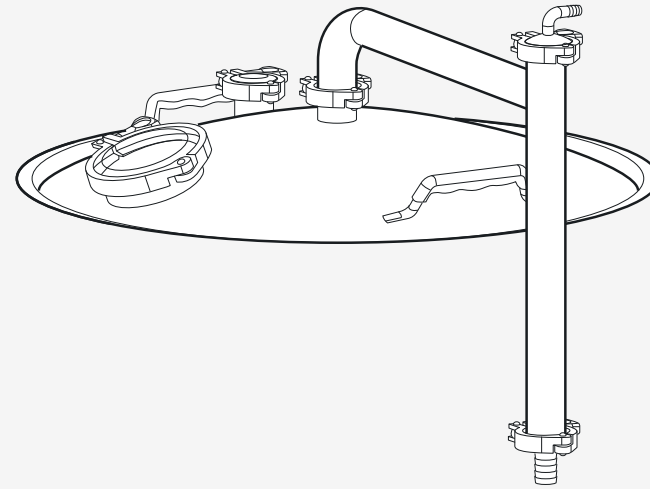

1. Assemble your Steam Condenser Lid as outlined on page 11.
2. Grab a 5 gallon or larger container to use as your pump reservoir.
3. Place the submersible pump into the reservoir and stick it to the bottom using the suction feet.
4. When getting ready to boil, fill the container with cold water.
5. Leave the steam condenser lid off when approaching boil to avoid any boil over. Once the hot break has subsided, you can place the steam condenser lid on.
6. Run the condenser lid output hose into a floor drain or collection container.
7. Make sure that the exit hose isn't submerged underwater and can drip freely. If submerged, back pressure will force the steam out where the lid and kettle meet.
8. Turn on the submersible pump.
(Water will begin to flow from the reservoir container, go up through the misting nozzle, and through the top of the condenser piping. This process creates a vacuum by cooling the steam into a liquid. The liquid will then flow out of the bottom of the piping into your collection container.)
9. Boil for the duration of time required by your recipe.
10. Keep an eye on the steam condenser water reservoir so it doesn't run dry. As it empties, refill it with cold water.



Brew Day – Boiling

Follow these steps to keep things rolling during the boiling phase.

PRO TIP: The BK PID is based on % power output to fine tune a rolling boil. This is opposed to the temperature control like the HTL and MT.

1. Once the elements are submerged the BK can be set to 100% and turned on. Press  3 times until you see **'OUT'**.
2. Use the **Up** and **Down** arrows to change the % power output and press  to set the output. Press  again to see the temperature readout screen.

3. To begin your boil, we recommend setting the temperature to 100% output to get the boil started. When the BK is nearing boil, be sure to watch out for hot break and boil overs.
4. Once the hot break has passed you can cover the BK with the steam condenser lid and reduce the BK PID to roughly 40-50% output. If not using the lid, set the PID to 80-90%.
5. Fill your steam condenser bucket (provided by the brewer; we recommend a 5gal bucket) with cool water and place the condenser pump in it.

PRO TIP: The steam condenser will use about 20gal of water during a brew day.

6. Boil for the amount of time called out by the recipe and watch that the steam condenser reservoir doesn't run dry.

Brew Day – Whirlpool

Figure 6

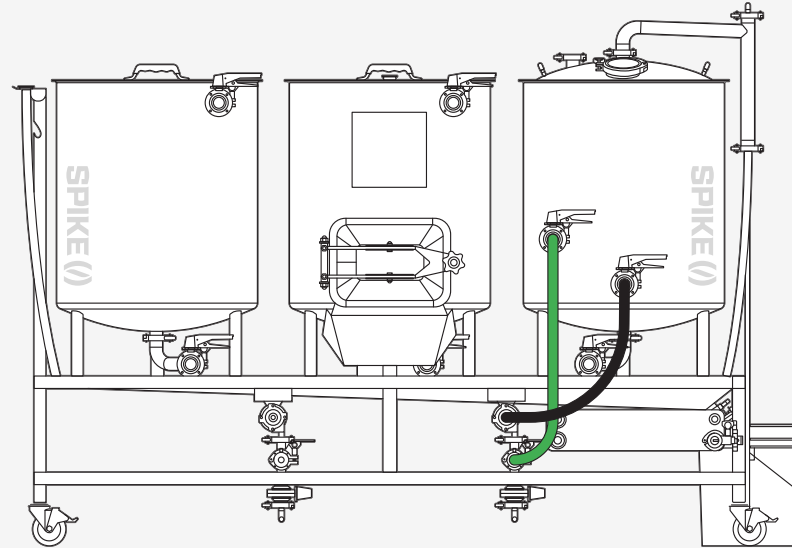

1. Move the short hose (**Black**) from the bottom port of the MT to the BK. (see **Figure 6**)
2. Turn wort pump on and whirlpool for 15 minutes. Lastly, let wort stand for 10 minutes before moving to knockout.

Brew Day – Knockout & Transfer

Figure 7

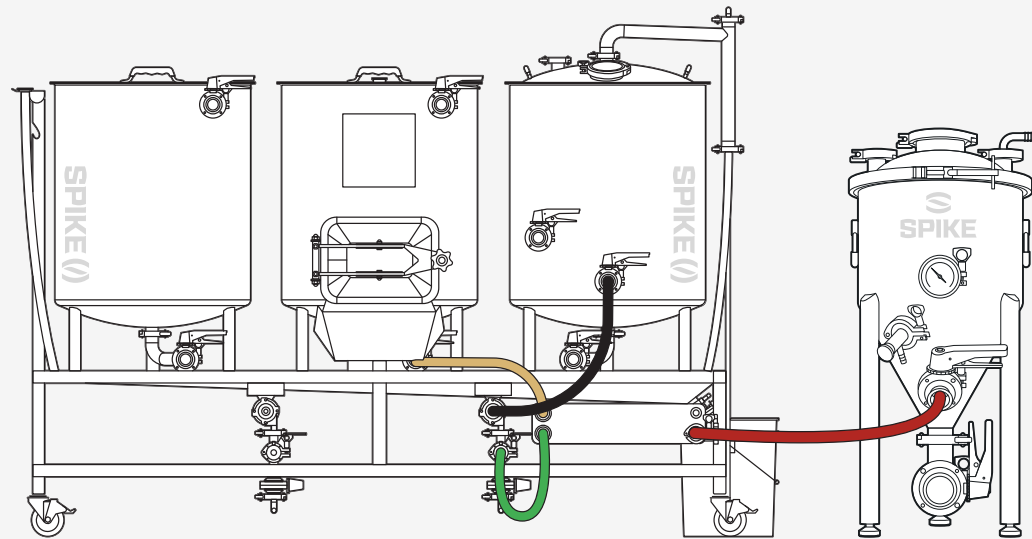

1. Move the hose (**Green**) from the whirlpool port to the 'Wort In' on the chiller. (see **Figure 7**)
2. Move the hose (**Black**) from the bottom drain on the MT to the racking port on the BK. (see **Figure 7**)
3. Attach a garden hose to the 'Water In' on the heat exchanger.

PRO TIP: Before proceeding make sure the MT has been emptied of grain and rinsed down. The water exiting the heat exchanger will be roughly 155F and can be used for CIP.

4. Attach a hose (**Gold**) from the "Water Out" to the bottom drain of the MT.
5. Ensure the heat exchangers inline temp probe is plugged into the panel.

PRO TIP: The best way to lower "Wort Out" temps is to slow the flow from the wort pump by using the ball valve. Increasing the flow of "Water In" can help as well but will use more water.

6. Open the valves and turn the wort pump on.
7. Adjust the flow on the wort pump outlet until the correct pitch temp is read on the panel's heat exchanger PID.

Brew Day – Cleaning

Follow these steps to speed through the cleanup process and keep your equipment running smoothly for your next Brew Day.

PRO TIP: Since the HLT and water pump are only used for clean water, they do not need to be cleaned after brewing.

1. Before CIP (Clean In Place), we recommend opening the bottom drain on each of the three kettles, and rinsing all loose material (hops, malt, etc) onto the drip tray. Also, remove the false bottom and scrub the kettle walls in the MT and BK with a soft brush.
2. Backflush the wort chiller by pumping hot water through it in the opposite direction. Send the water into the “Wort Out” port and out through the “Wort In” port then into a drain.
3. Your MT will have hot reclaimed water from the knockout stage; 10 gallons of reclaimed water will be enough. The water should be roughly 150F, which is the heat recommended for most caustic cleaning chemicals. If the water is below 150F, use the MCS heater to raise it. You can add your caustic to the MT as prescribed by the caustic instructions.
4. Move the hose (**Gold**) from the heat exchanger ‘Water Out’ to the wort pump inlet. (see **Figure 8**)
5. Move the hose (**Black**) from the wort pump inlet to the wort pump outlet. Move the other end from the BK racking port to the top port on the MT. (see **Figure 8**)

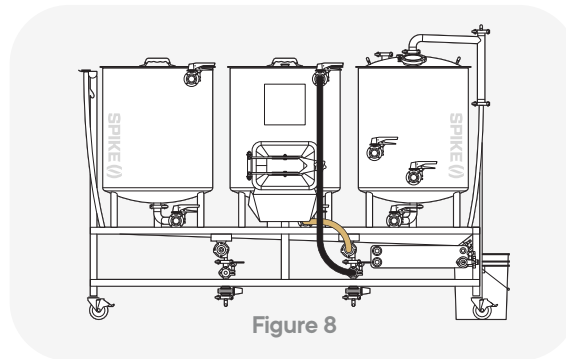

6. Attach the vorlauf arm to the inside of the MT and turn the wort pump on. Let this run for a minute or until the plate and tube have been cleaned.
7. Turn the wort pump off.
8. Close the 3-piece valve and open the bottom bleed valve. This will ensure the bleed system is cleaned.
9. 3 piece valves are great at giving precise flow control but they are a little harder to clean. Turn the pump on, open and close the 3 piece valve slowly to make sure the ball and seats are cleaned thoroughly.
10. Turn off the pump and attach the CIP ball to the flat lid with the 1.5” TC port. Add this lid to the MT.
11. Move the hose (**Black**) from the top port on the MT to the CIP ball. (see **Figure 9**)

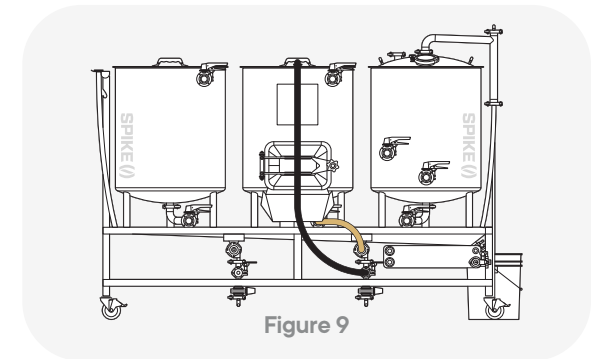

12. Turn the wort pump on and let the CIP ball clean the inside of the tank for about 5 minutes. Turn the wort pump off and inspect inside for any areas that didn't get cleaned. If there are areas that are still dirty a quick hand scrub with a brush or more time with the CIP ball might be needed.
13. Once the MT is cleaned move all the liquid from the MT to the BK.
14. Move the hose (**Black**) from the top CIP ball port to the bottom drain of the BK. (see **Figure 10** on next page)
15. Turn on the wort pump until all the liquid is drained from the MT.

Continued on next page.

Brew Day – Cleaning

Follow these steps to speed through the cleanup process and keep your equipment running smoothly for your next Brew Day.

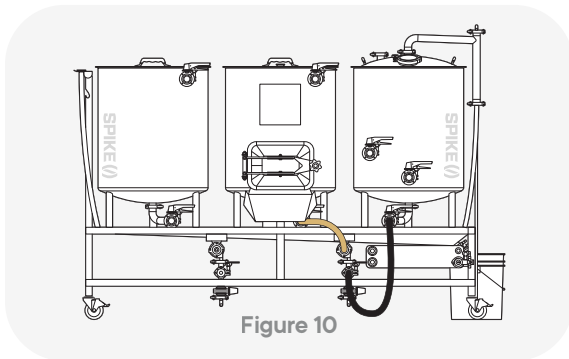

16. Attach the (Green) hose from the BK drain to the wort pump inlet. (see **Figure 11**)
17. Attach the (Red) hose from the wort pump outlet to the “Wort Out” port on the chiller. Attach the (Gold) hose from the “Wort In” port of the chiller to the BK racking port. (see **Figure 11**)

PRO TIP: The heat exchanger should be flushed clean with the opposite flow direction used when knocking out. This is so any particulates that made it into the heat exchanger get flushed out instead of pushed further into the heat exchanger.

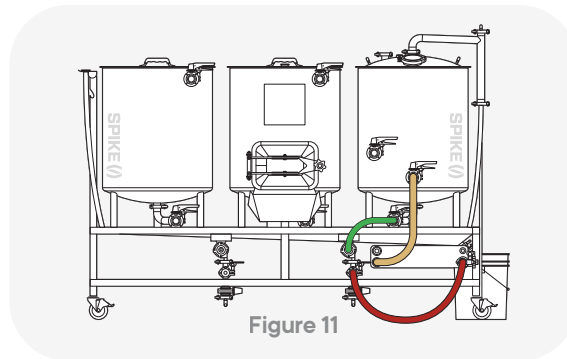

18. Turn on the wort pump for about 5 minutes. This will clean the racking arm and racking valve.
19. Move the hose (Gold) from the BK racking port to the BK whirlpool port.. (see **Figure 12**)
20. Turn on the wort pump for about 5 minutes. This will clean the whirlpool arm and whirlpool valve.

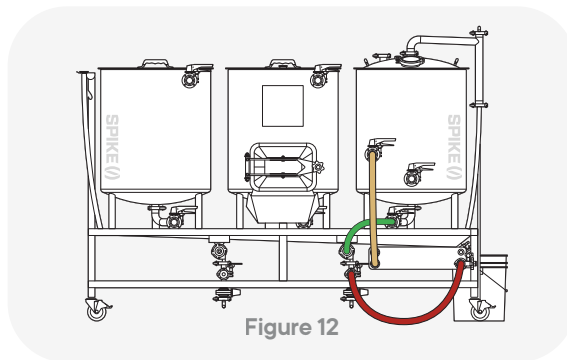

21. Remove the (Gold) hose. Remove the steam condenser tube and move the hose (Red) from the Wort Out port to the bottom of the steam condenser. (see **Figure 13**)
22. Turn on the wort pump for about 2 minutes. This will clean the steam condenser piping.
23. Remove the cap from the BK steam condensing lid. Move the CIP ball from the MT lid to the BK lid.

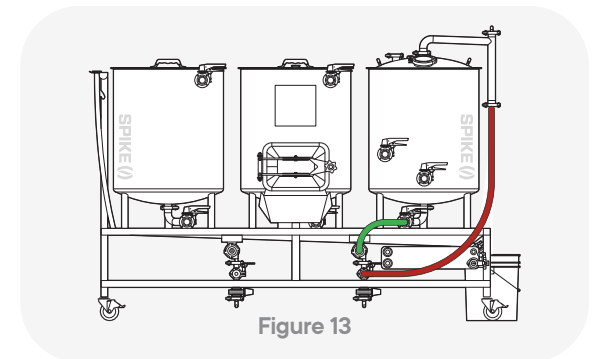

Continued on next page.

Brew Day – Cleaning

Follow these steps to speed through the cleanup process and keep your equipment running smoothly for your next Brew Day.

Figure 14

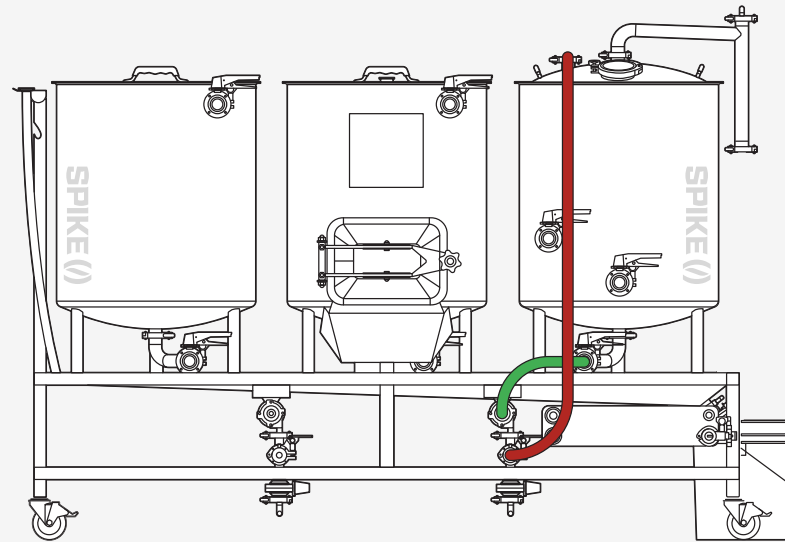

24. Move the hose (**Red**) from the bottom of the steam condenser piping to the CIP ball. (see **Figure 14**)
25. Turn the wort pump on and let the CIP ball clean the inside of the tank for about 5 minutes. Turn the wort pump off and inspect inside for any areas that didn't get cleaned. If there are areas that are still dirty a quick hand scrub with a brush or more time with the CIP ball might be needed.
26. Drain the BK. After the BK is drained, rinse the MT and BK with hot water.
27. Step 1-27 should be repeated with clean water to flush the system of the caustic cleaner.
28. Steps 1-27 can be repeated with a sanitizer as well.
29. After CIP'ing the tanks, remove all port fittings to check for organic material that didn't get washed away. Use a brush to scrub the elements and disassemble the MT Bottom Piping and rinse off any grain material
30. Once the system is fully cleaned, place the lids on all the tanks to avoid dust getting inside and open all valves so everything can air dry.