

# Spike Carb Stone & All-In-One PRV

User Guide



# Congrats on adding the Spike Carb Stone and/ or All-In-One PRV! You can now do even more with your fermenter.



We know you're anxious to get brewing, so we made these assembly instructions and Brew Day Guide easy for you to follow and threw in a few pro tips along the way.

Grab a beer, and let's get started.

**NOTE:**

The Spike Carb Stone and All-In-One PRV can be purchased individually or together in our Carb Stone Bundle. This guide details processes that use one or both products. Each process specifies which you will need.

- 01. Assembly** ..... 2
  - Warnings..... 3.
  - Carb Stone..... 4.
  - PRV..... 6.
  - PRV Set Up..... 8.
  
- 02. Brew Day Guide** ..... 9.
  - Oxygenate..... 10.
  - Pressure Fermentation..... 11.
  - Spunding ..... 12.
  - Cold Crash..... 13.
  - Dump Yeast ..... 14.
  - Force Carbonate..... 15.
  - Pressure Transfer..... 16.
  - Cleaning ..... 17.

01.

---

# Assembly

Ready to upgrade your fermenter? This guide will show you how to assemble each piece of equipment with step-by-step instructions and key visuals.

**Warnings**

**Carb Stone Assembly**

**PRV Assembly**



# WARNING

- Always treat vessel as if pressurized
- Do not touch or remove conical lid clamp without complete depressurization
- Relieve pressure in the vessel by gently depressing top knob
- Never place a valve before your PRV as this renders the PRV ineffective

**FAILURE TO FOLLOW THESE INSTRUCTIONS CAN CAUSE THE LID TO DISLodge RESULTING IN INJURY OR DEATH**

Assembly –  
**Carb Stone**

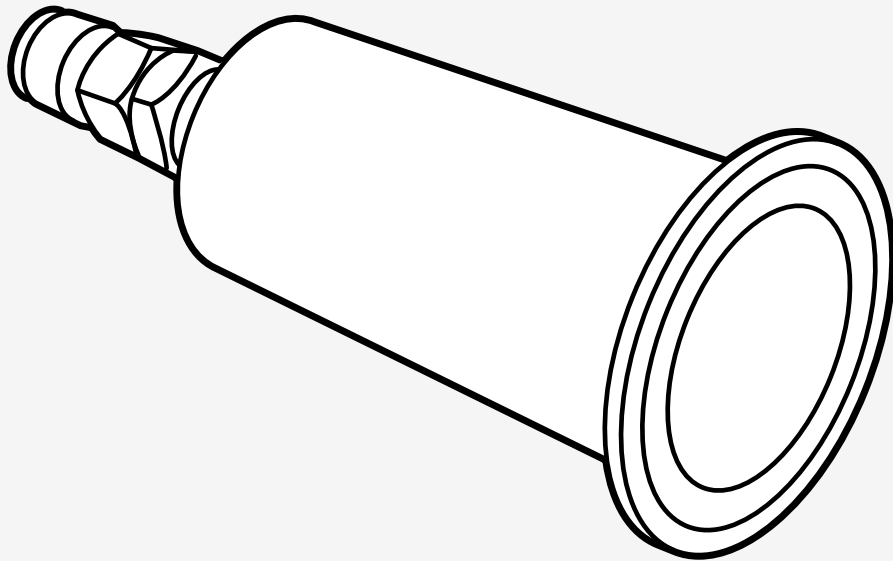

## Assembly – Carb Stone

1. Attach the included gas post to the carb stone housing. Use 3–4 wraps of Teflon tape on the threads. Tighten using a wrench.

**PRO TIP:** Be sure to not over tighten the o-ring on the gas post as this can cause leaking to occur.

2. Before use always sanitize by submerging or thoroughly spraying the carb stone assembly with Star San.
3. Using a sanitized gasket and clamp, attach to your conical fermenter's racking port butterfly valve.

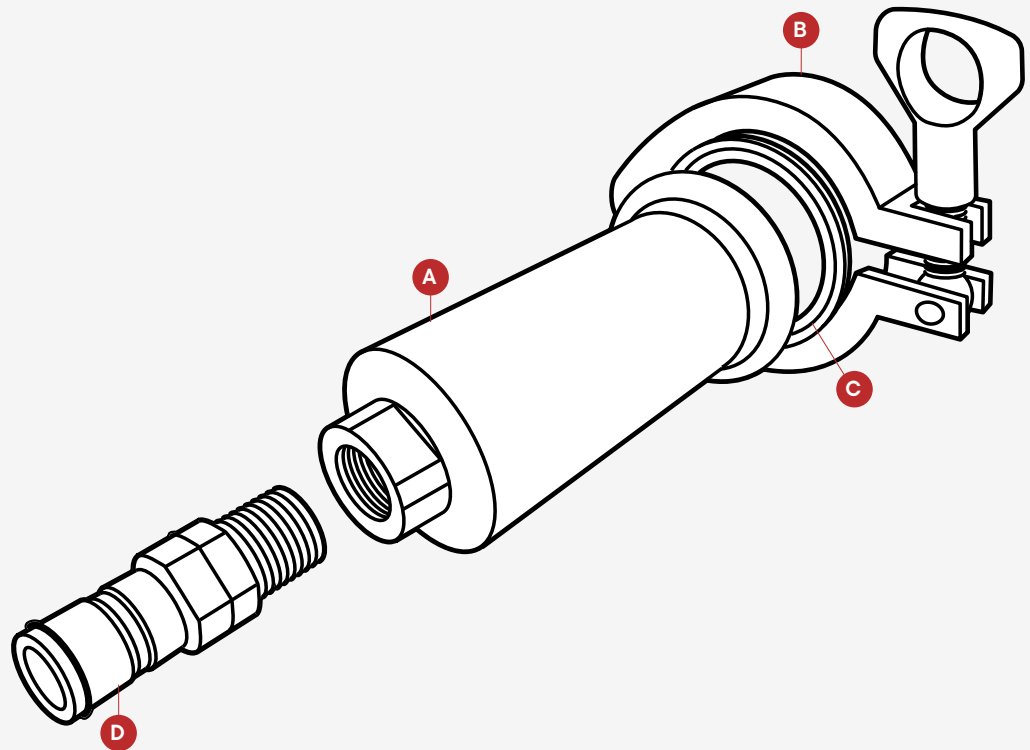

ITEM	DESCRIPTION	QTY
A	Carb Stone	1
B	1.5" Clamp	1
C	1.5" Gasket	1
D	Gas Post	1

Assembly –  
**PRV**

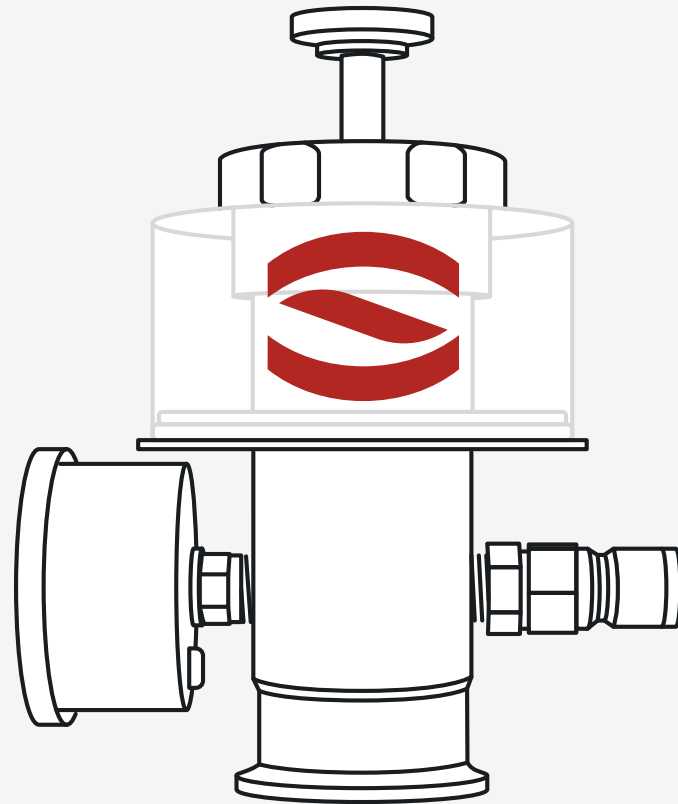

# Assembly – PRV

1. Attach the included gas post and pressure gauge to the PRV housing. Use 3–4 wraps of Teflon tape on the threads. Tighten using a wrench.

**PRO TIP:** Fill the sanitizer cup with sanitizer solution.

2. Attach the assembled PRV to the lid of a fermenter with a 1.5" clamp and gasket.
3. Tightening the knob clockwise all the way will set your PRV to 15psi.

ITEM	DESCRIPTION	QTY
A	Adjustment Knob	1
B	Gas Post	1
C	Pressure Gauge	1
D	Sanitizer Cup	1
E	Drain Cap	1
F	Plunger	1

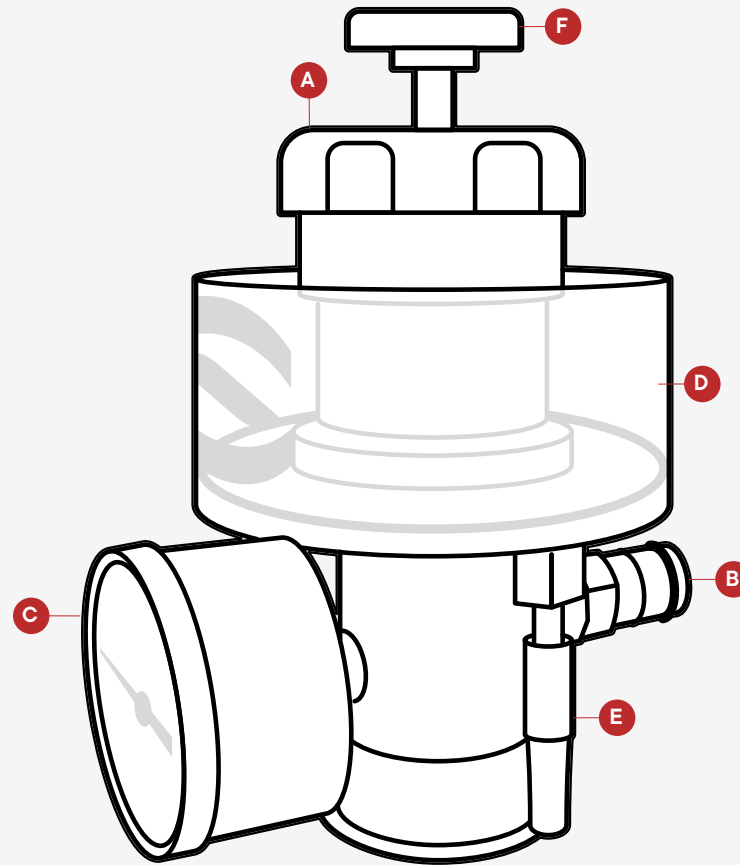



## Assembly – PRV Walk Through

### A. Adjustment Knob

This is how your pressure setting is increased or decreased. To increase your pressure turn the knob clockwise. Once bottomed out your pressure release will be 15psi. To lower your pressure setting turn the knob counter clockwise.

### B. Ball Lock Gas Post

You can attach your CO2 tank to your fermenter via this port. This is helpful for adding pressure when carbonating or pressure transferring.

### C. Pressure Gauge

This is how pressure is set and read in your fermenter. Using the adjustment knob you can set the release pressure and verify that it is correct by using your gauge. This is also a visual indicator if there is pressure in the tank. However, always double check if there is pressure by pushing down the plunger (F).

### D. Sanitizer Cup

This can be filled with sanitizer to create an airlock. This is similar to a blowoff bucket or airlock bubbler.

### E. Drain Cap

By removing this cap you can drain the sanitizer from the sanitizer cup. This allows for bleeding pressure using the plunger (F) without getting sprayed with sanitizer.

### F. Plunger

The plunger is used to reduce pressure or completely void the fermenter of pressure. Simply press down on the plunger to open up the valve and allow pressure to escape.

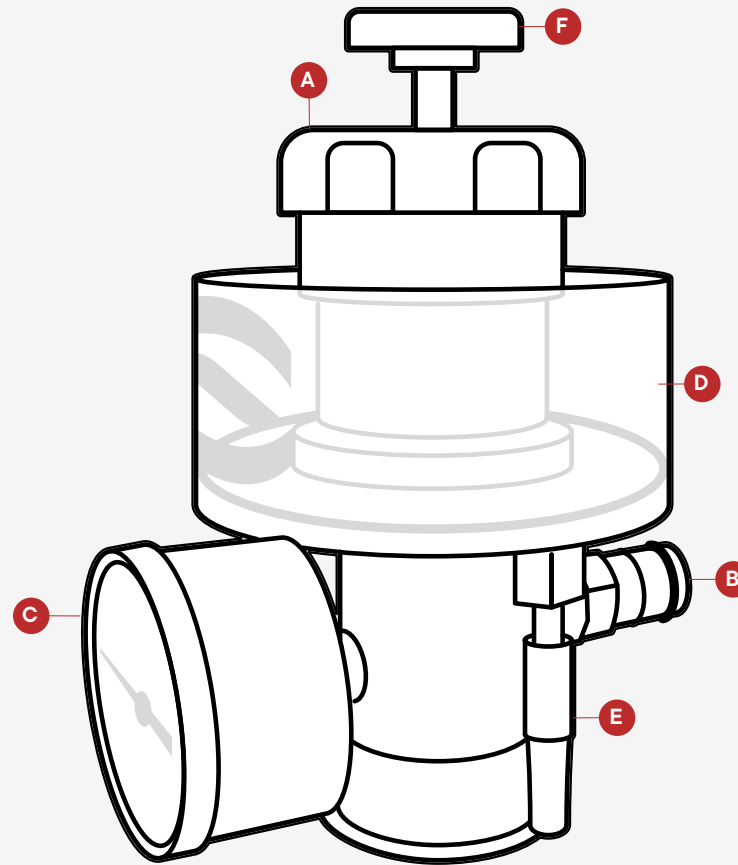

# Brew Day Guide

It's time to put your fermenter upgrades to work!

Follow the steps in this user guide for a simple and easy Brew Day experience.

**Oxygenate**

**Pressure Fermentation**

**Spunding**

**Cold Crash**

**Dump Yeast**

**Force Carbonate**

**Pressure Transfer**

**Cleaning**

## Brew Day – Oxygenate

### Equipment Needed: Carb Stone

After you have transferred your wort from your boil kettle and chilled to yeast pitch temps, you are ready to oxygenate

1. Grab your carb stone and sanitize the inside and TC flange. Also sanitize the racking valve, clamp and gasket.
2. Attach the carb stone to the racking port.
3. Using the quick connect gas post on the carb stone, connect to your oxygen tank. (see **Figure 1**)
4. Turn on the oxygen tank and open the racking valve, leaving open for 30 seconds – 1 minute. While you do this, make sure that the blow off hose at the top of the conical is inserted into your sanitizer bucket, so you don't create excess pressure in the conical.
5. Close the racking valve, turn off the oxygen, disconnect the oxygen tank and disconnect the carb stone.
6. Spray the outside of the butterfly valve down with sanitizer. Clean the carb stone by soaking it in Alkaline Brewery Wash or similar product.
7. After the carb stone has soaked, rinse with warm water and attach the stone to your CO2 tank to push all residual wort and brewery wash out of the stone's porous body. Follow this with a spray with sanitizer.
8. After you oxygenate, you are ready to pitch your yeast and begin fermentation!

Figure 1

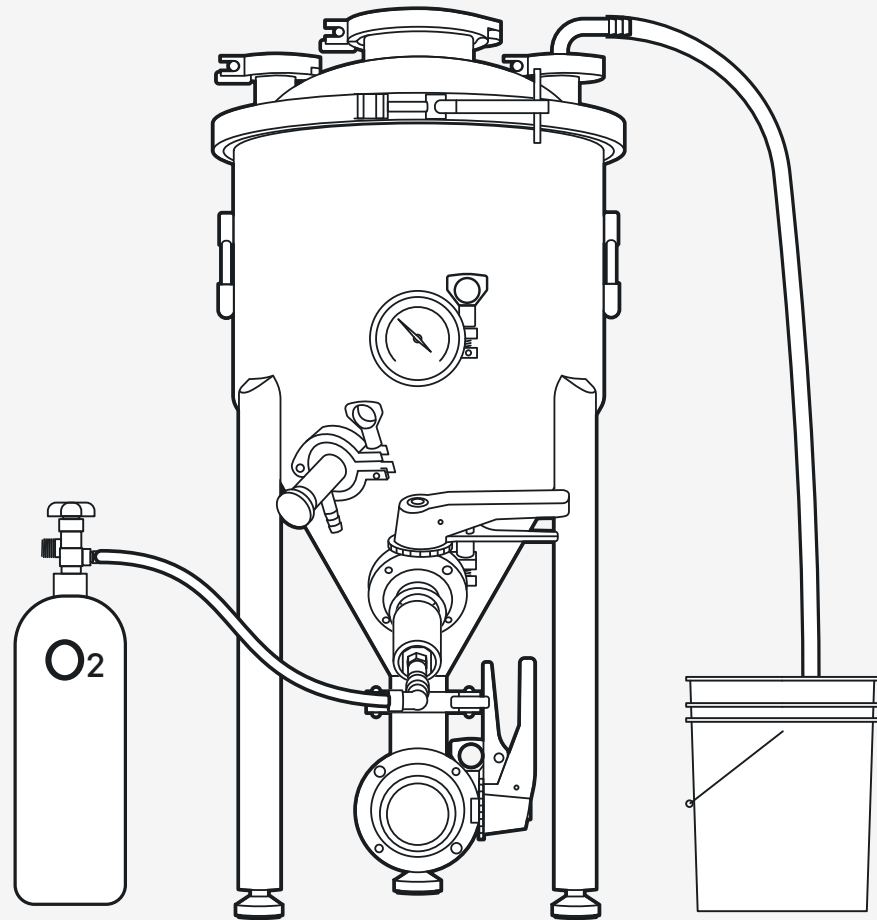

## Brew Day – Pressure Fermentation

### Equipment Needed: All-In-One PRV

Pressure fermentation is an advanced technique brewers use for certain beers. Fermenting under pressure causes the yeast to produce less esters. In certain beer styles, esters cause an undesirable flavor. Another application is combining pressure fermenting and warmer temperatures to ferment lager yeasts at higher temperatures without producing off flavors. Lastly, the beer will also be carbonated at the end of pressure fermentation. That process is called spunding and is discussed in more detail on the next page.

#### NOTE:

Working with a pressurized tank can be dangerous and is only recommended for trained professionals or those with advanced brewing knowledge.

Remember to:

- Not touch or removed the conical lid clamp without complete depressurization
- Relieve pressure by depressing the top knob
- Never place a valve before your PRV as this renders the PRV ineffective

Failure to follow these instructions may result in injury or death

Figure 2

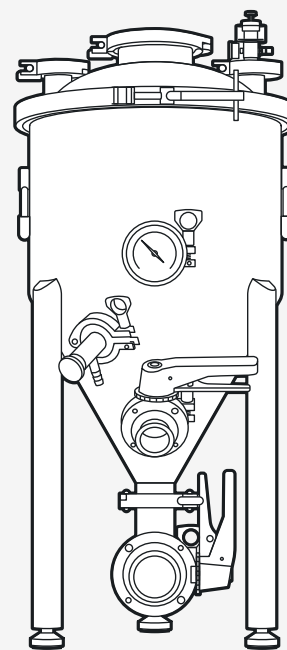

1. Follow pages 6 and 7 of this guide to properly set up your PRV
2. Add the PRV to the fermenter lid after filling it with wort (see **Figure 2**)
3. Use the Adjustment Knob to adjust the pressure the PRV releases at.
4. Note: the pressure setting can vary on the beer style and yeast, between 5 and 10psi is most common
5. Fill the Sanitizer Cup with a sanitizer solution. The PRV will be constantly relieving pressure during primary fermentation, so it is best to let the CO2 escape through sanitizer rather than the air
6. When fermentation is complete, proceed to Cold Crashing

# Brew Day – Spunding

## Equipment Needed: All-In-One PRV

Spunding is typically done at the end of fermentation (also known as secondary) as to not stress the yeast. Spunding allows for collecting the CO<sub>2</sub> produced during fermenting to carbonate the beer naturally. Note that if you pressure fermented that you have already carbonated your beer in this manner. In that case, skip to step 5 below.

### NOTE:

Working with a pressurized tank can be dangerous and is only recommended for trained professionals or those with advanced brewing knowledge.

Remember to:

- Not touch or removed the conical lid clamp without complete depressurization
- Relieve pressure by depressing the top knob
- Never place a valve before your PRV as this renders the PRV ineffective

Failure to follow these instructions may result in injury or death

Figure 3

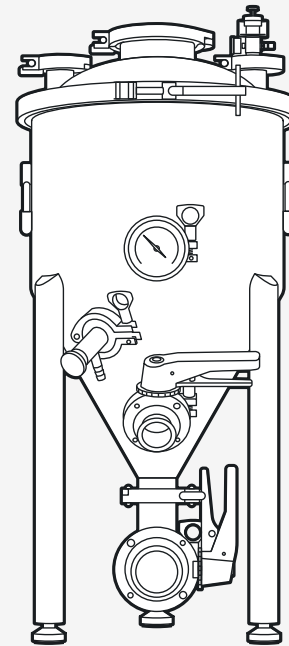

1. Follow pages 6 and 7 of this guide to properly set up your PRV
2. Add the PRV to the fermenter lid after primary fermentation slows down. This is typically when the gravity is about 5 gravity points above the target final gravity (see **Figure 3**)
3. Fully tighten the adjustment knob to set the PRV release point at 15 psi. This will allow the fermenter to capture as much CO<sub>2</sub> as possible
4. Fill the Sanitizer Cup with a sanitizer solution. The PRV will be constantly relieving pressure after it reaches 15psi so it is best to let the CO<sub>2</sub> escape through sanitizer rather than the air
5. Once fermentation is complete, proceed to Cold Crashing (next page ). Note that during cold crashing, the pressure may drop below the pressure for your target carbonation level. In this case, follow our Force Carbonation Process (Page 15) to increase the carbonation.

## Brew Day – Cold Crash

### Equipment Needed: All-In-One PRV

When lowering your conical from higher fermentation temps to cold crash temps, a vacuum can be created. When a vacuum is created inside your conical and blow off tube is still attached, the sanitizer can be sucked up through the blow off and into your conical. Prevent this by removing the blow off tube, sealing the tank with the PRV, and adding pressure as described below. Once fermentation is complete, you can cold crash your beer to help yeast and other solids settle in the cone.

Use our TC-100 temp control package and a cold-water source or glycol chiller to achieve appropriate cold crash temps (we recommend cold crashing to 38F).

Figure 4

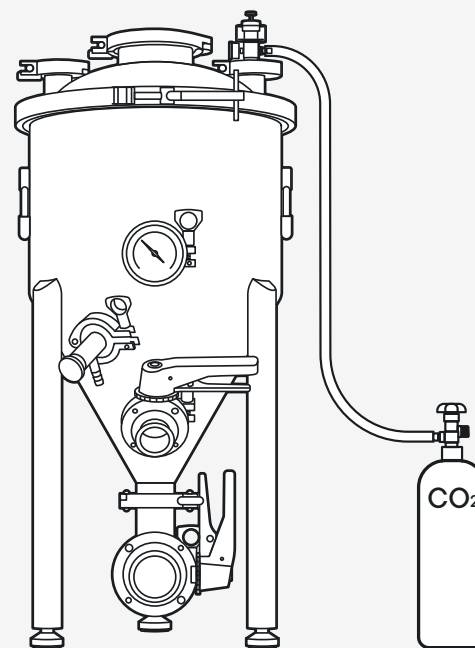

1. If not already installed, sanitize your PRV and attach it to the lid.
2. Remove the blowoff tubing and replace it with a 1.5" cap.
3. Connect your CO2 tank to the gas post on the PRV and add pressure until the pressure gauge reaches 5psi. (see **Figure 4**)
4. This added pressure will prevent a vacuum from forming inside your tank as temps are lowered.
5. Turn off your CO2 tank and disconnect from the gas post.
6. To set your temp, press the down button on your controller until the 'SET' temp reads 38F.
7. This chilling process will take between 12-24 hours depending on the temperature of your cold-water source, ambient temps, etc.

**PRO TIP:** If you are using a glycol chiller, we recommend setting your chiller to 28F and using a 1:1 distilled water to propylene glycol mixture.

## Brew Day – Dump Yeast

### Equipment Needed: All-In-One PRV

After cold crashing, you can dump the yeast that has settled in the cone. To dump the yeast, we recommend using our silicone tubing and either our tri clamp barb fitting or tri clamp quick connect fitting. For the quickest and easiest connection, we will use and recommend the quick connect fittings.

1. Sanitize the quick connect fittings and the 2" butterfly valve.
2. Connect the hose to the bottom 2" TC x QC fitting, leading to a drain or bucket. (see **Figure 5**)
3. Attach the PRV to a 1.5" TC lid port (if it isn't already), then connect to your CO2 tank via the gas post.
4. Turn on the CO2 tank and set your regulator to about 5psi. Once the pressure gauge on the conical has reached 5psi, you can open/close the butterfly valve again.
5. Slowly open your valve and drain until the liquid runs clear. We emphasize **slowly** here. Opening too quickly

Figure 5

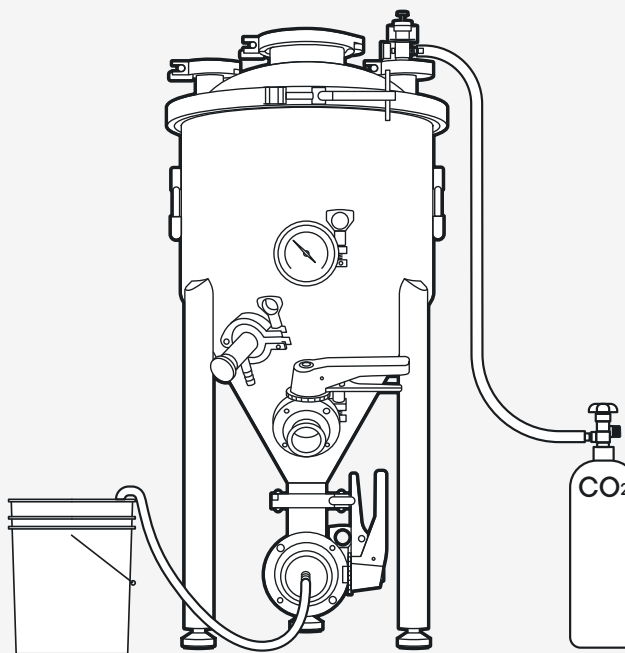

6. If you have pitched a large amount of yeast or had multiple hop additions in the fermenter, you may experience a stuck yeast dump limiting flow out of the conical. In that case, open and close the butterfly valve a few times to break up the blockage.
7. Turn off the CO2 tank and disconnect from the PRV.
8. Once you've finished dumping the yeast, close the bottom butterfly valve and disconnect the hose and fitting. Make sure to spray everything down with sanitizer again.

**PRO TIP:** As an alternative to dumping your yeast, you can reuse by yeast harvesting.

## Brew Day –

# Force Carbonate

### Equipment Needed:

#### Carb Stone & All-In-One PRV

Figure 6

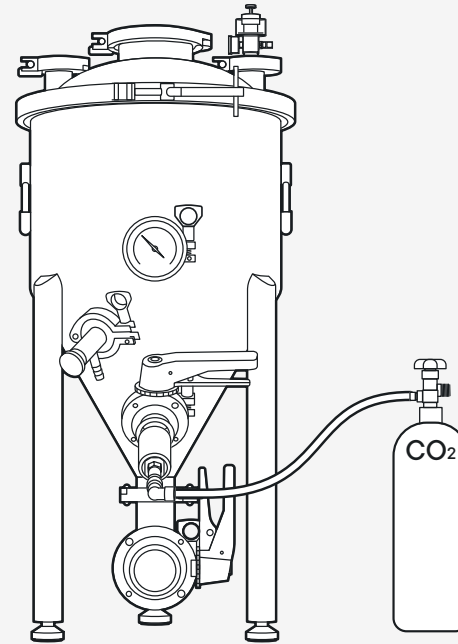

1. After cold crashing, keep your beer cold and hold 1-2psi of pressure.
2. Attach a cleaned and sanitized carb stone to the racking port using a clamp and gasket.
3. Ensure that your CO2 tank is OFF
4. Connect your CO2 tank to the carb stone. (see **Figure 6**)
5. Use the Spike Carb Chart to determine the amount of CO2 pressure needed based on your conical temperature and desired carbonation level.
6. Set your CO2 tank regulator about 4psi higher than the target pressure for your conical. This will account for the carb stone's wetting pressure.
7. Open your racking valve to allow pressure to start flowing. It usually takes about 5 minutes for the tank to reach full pressure. Leave your CO2 tank attached for 12-24 hours to achieve full carbonation.
8. Once fully carbonated, close your racking valve, turn off the CO2 tank and remove the carb stone. Clean the carb stone and spray the outside of the valve with sanitizer.



## Brew Day – Pressure Transfer

### Equipment Needed: All-In-One PRV

Purge your cleaned and sanitized keg of oxygen before filling. To do so, connect your CO2 tank to the “IN” side of the keg and let the keg build pressure. Pull the pressure relief valve a few times to purge the keg of oxygen.

When pressure transferring, keep the conical pressure gauge at roughly 5psi to help push the beer out. Use the PRV bundle to achieve this.

1. Using the Spike pressure transfer kit, attach the hose with the 1.5" tri clamp to the racking port and connect the black ball lock to the “OUT” ball lock post on the keg. (see **Figure 7**)
2. Fill a bucket with sanitizer for use with a blow off. You can use the same bucket that you used previously for your blow off.
3. Open the racking valve. Beer will begin to flow into your keg.
4. Once the beer starts to flow, insert the bare end of the other hose in the blow off bucket and the gray ball lock to the “IN” ball lock post on the keg.
5. Once you see beer foam out of the blow off, you keg is full. Close the racking valve. If a second keg is needed, repeat the process of purging, connecting, and transferring the beer until your conical is empty.

Figure 7

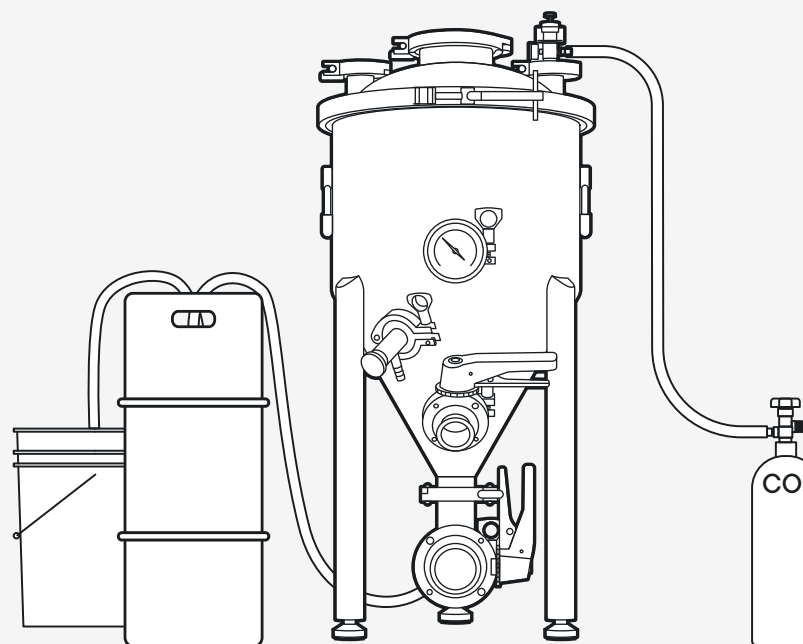

**PRO TIP:** If you are using a racking arm, we recommend starting your transfer with the racking arm in the up position and you can slowly rotate the racking arm down until the wort no longer runs clear. The position of the racking arm can be determined by using the indicating post welded to it. To turn the racking arm, loosen the clamp that attaches it to the conical by about 1 turn. Using the valve handle as leverage, you'll be able to slowly turn the racking arm to the desired position.

6. Once the conical is fully drained, close the racking valve, turn off your CO2, then disconnect your keg and the hoses from the CO2 source.
7. Purge all the pressure from your conical

## Brew Day – Cleaning

### Carb Stone

Soak in brewery wash for 12–24 hours and rinse with warm water. Then attach the stone to your CO2 tank to push all residual wort and brewery wash out of the stone's porous body. Follow this with a spray with sanitizer

### All in one PRV

Remove the pressure gauge and soak the PRV and gas post in brewery wash for 1 hour then rinse thoroughly with water

