

Hot Liquor Tank

User Guide



Before you begin

Make sure the elements are plugged in, and the power cords are fully twisted into position. We also recommend strain relieving the power cords so the full weight is not pulling down on the element connection. Taking these actions will certainly extend the life of your power cords.

Before installing parts into quick-connect (QC) fittings, be sure to lubricate them with water. This will allow them to slide into the QC fitting easily and prevent tearing the o-ring.

Assembly – Hot Liquor Tank

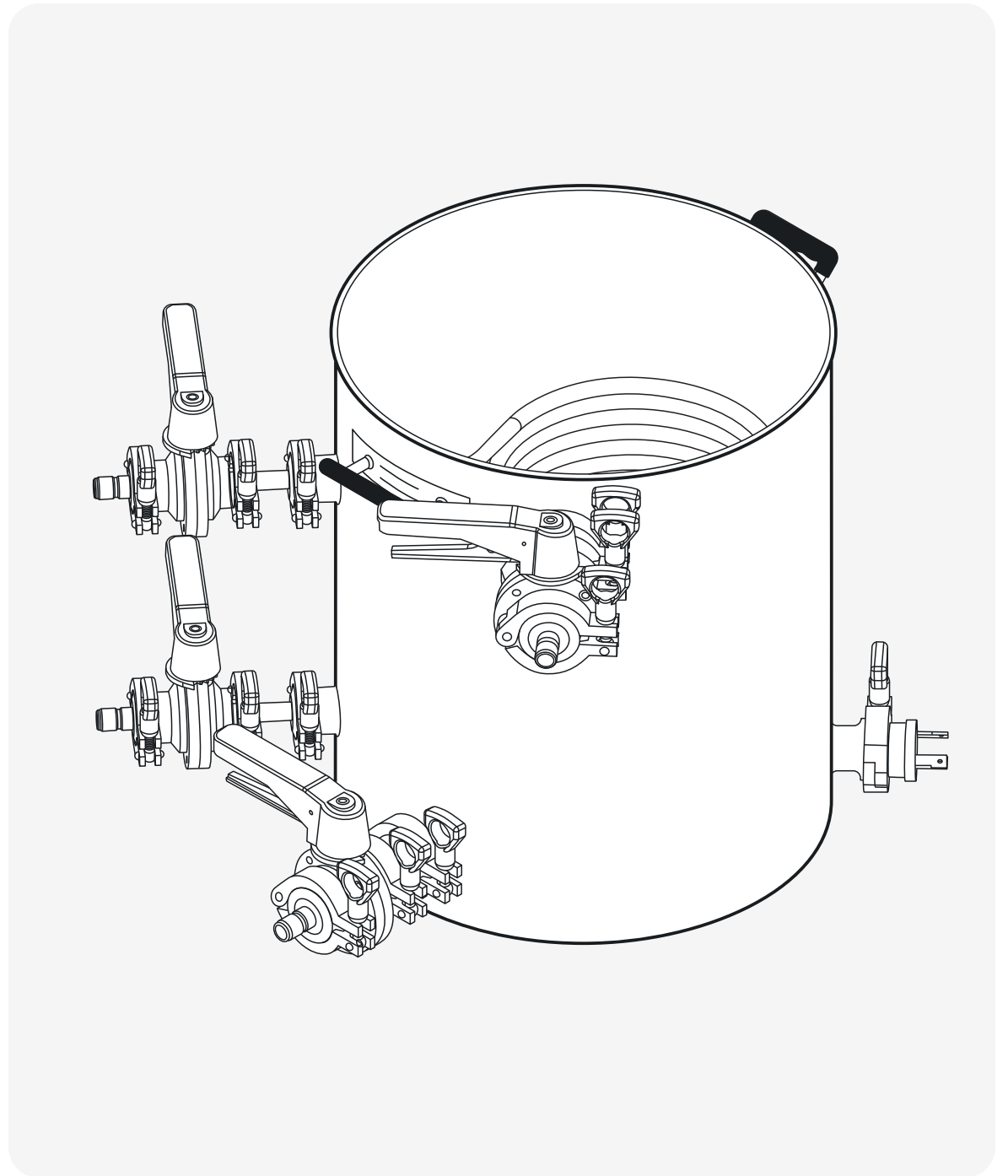

Assembly – Hot Liquor Tank

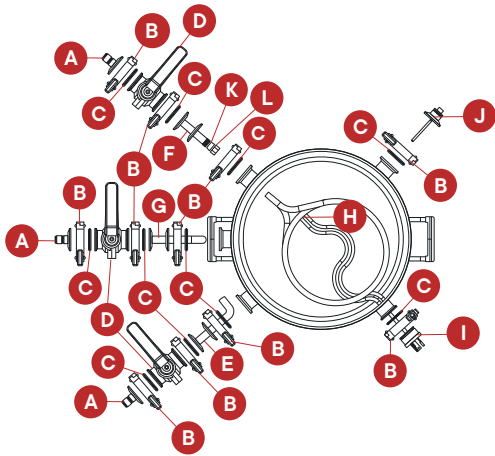

ITEM	DESCRIPTION	QTY
A	1.5" TC X QC	4
B	1.5" TC Clamp	14
C	1.5" TC Gasket	14
D	1.5" TC Butterfly Valve	4
E	Spike+ Pickup Tube - Side	1
F	1.5" TC HERMS Fitting	2
G	Spike+ Pickup Tube - Shorty	1
H	HERMS Coil	1
I	1.5" TC Element	1
J	1.5" TC Temp Sensor	1
K	Compression Seal	2
L	Nut	2

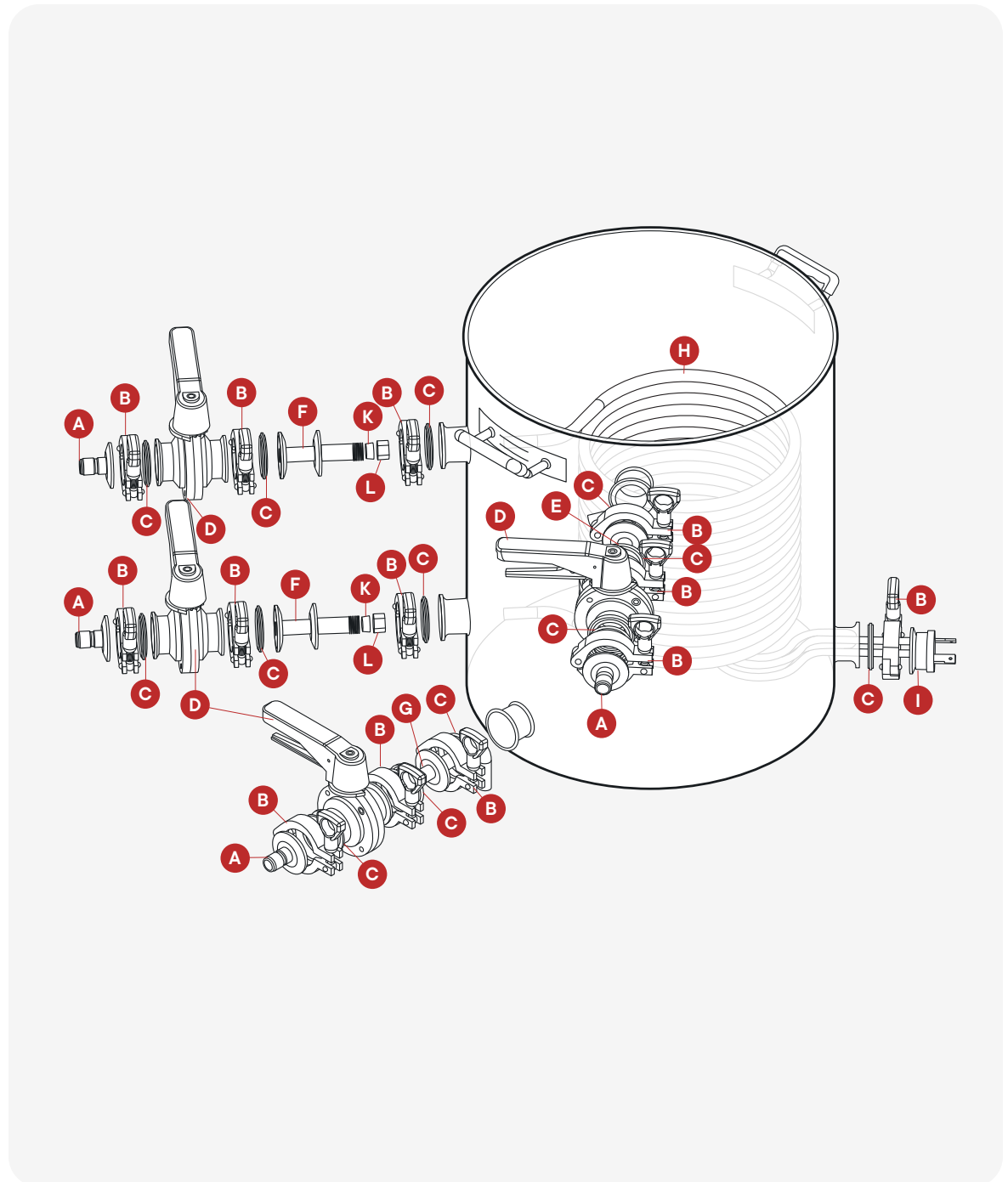

Assembly – HERMS Coil

Installing the HERMS Coil

1. Attach the TC HERMS fittings to the HERMS In and Out ports with a clamp and gasket.
2. Insert a Compression Seal (smaller end first) into the top HERMS fitting. (Wort Out Port).

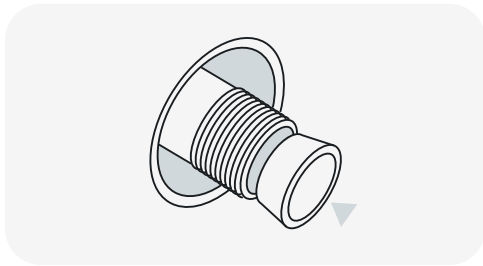

3. Slide the nut on to end of the HERMS coil tubing.

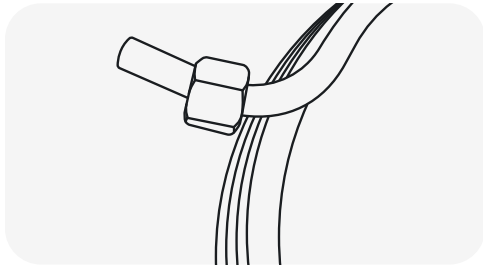

4. Insert the top of the HERMS coil into the Compression Seal.

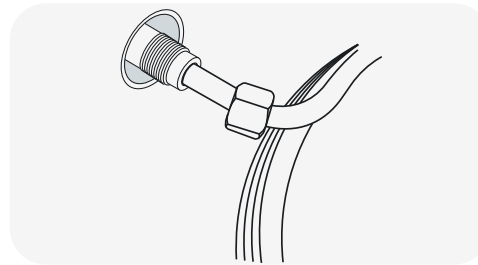

5. Slide the nut down and thread it on to the TC HERMS fitting as far as possible by hand. Use your other hand to support the weight of the HERMS Coil to make installation easier.
Note: Teflon tape is not needed for these threads.

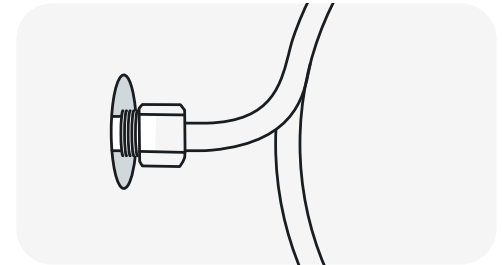

6. Use a wrench to further tighten the nut. An 8" adjustable wrench or a 15/16" wrench works well.
7. Repeat steps 4-6 on the Wort In (lower) port.

