

Spike Trio System

User Guide



Congrats on securing your new Spike Trio System!

We know you're anxious to get brewing, so we made these assembly instructions and Brew Day Guide easy for you to follow and threw in a few pro tips along the way.

Grab a beer, and let's get started.

01. Assembly	2.
Hot Liquor Tank	4.
HERMS Coil	6.
Mash Tun	7.
Boil Kettle	9.
Steam Condenser Lid	11.
Wort Chiller	13.
Tables	15.
Pumps	19.
Hoses	21.
02. Brew Day Guide	22.
Control Panel	23.
Set Up	24.
Mashing	26.
Sparging	27.
Using the Steam Condenser Lid	28.
Boiling	29.
Whirlpool	30.
Drain to Conical	31.
Cleaning (CIP)	32.

01.

Assembly

Ready to get your Trio up and running? This guide will show you how to assemble each piece of equipment with step-by-step instructions and key visuals.

Hot Liquor Tank

Mash Tun

Boil Kettle

Steam Condenser Lid

Wort Chiller

Pumps

Hoses

Before you begin

Make sure the elements are plugged in, and the power cords are fully twisted into position. We also recommend strain relieving the power cords so the full weight is not pulling down on the element connection. Taking these actions will certainly extend the life of your power cords.

Before installing parts into quick-connect (QC) fittings, be sure to lubricate them with water. This will allow them to slide into the QC fitting easily and prevent tearing the o-ring.

Want to mount your control panel on the wall? Attach it to a piece of plywood and affix it to the wall or use a TV mount with the proper weight capacity.

Assembly – Hot Liquor Tank

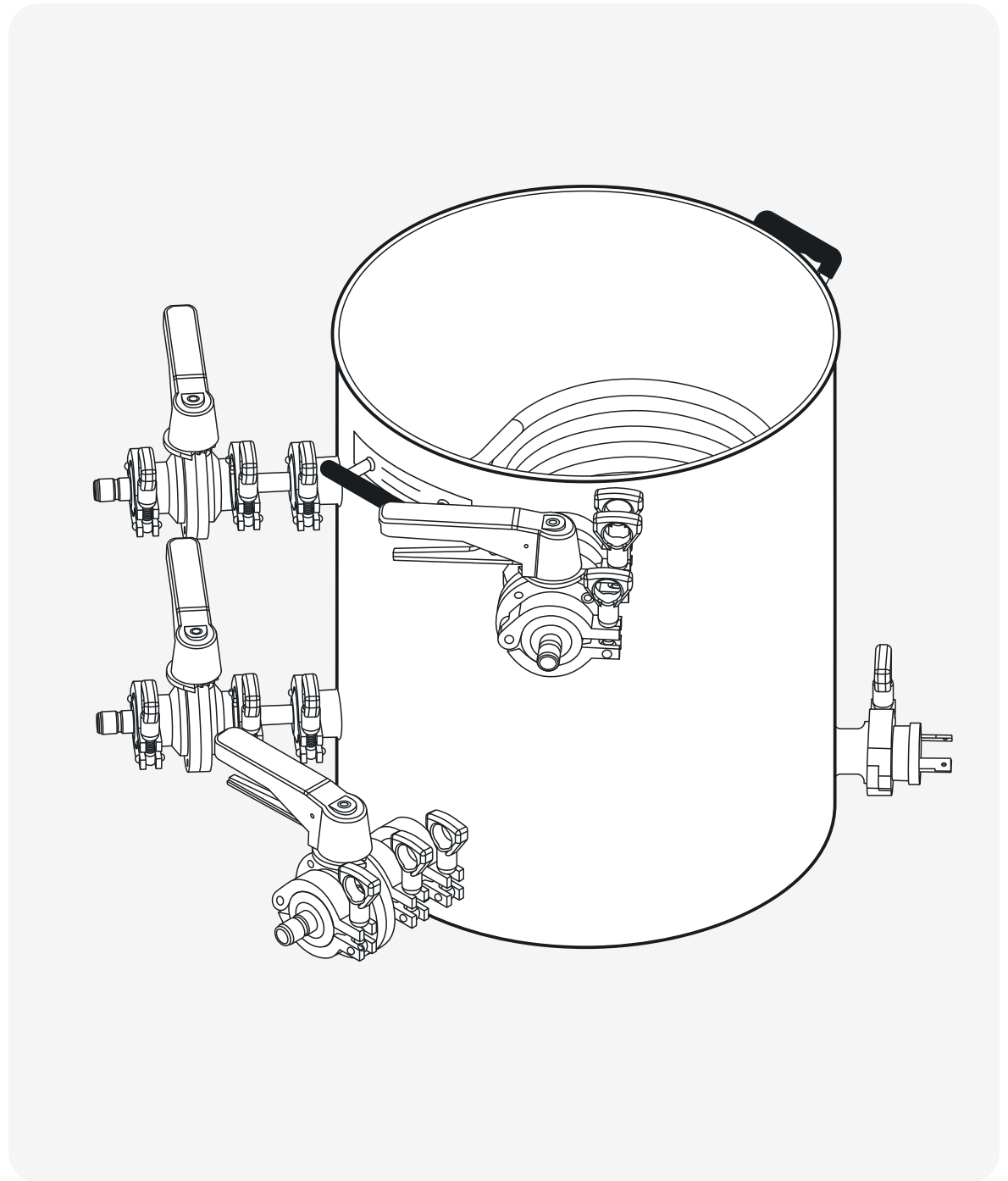

Assembly – Hot Liquor Tank

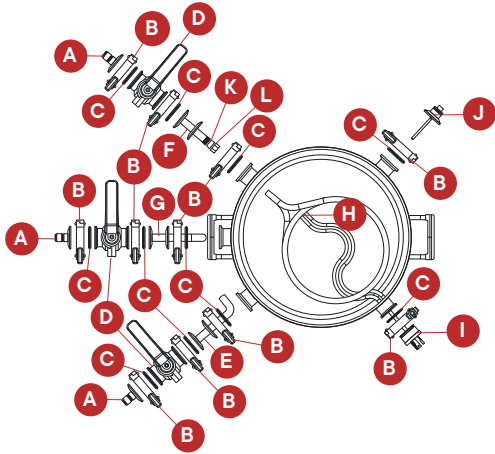

ITEM	DESCRIPTION	QTY
A	1.5" TC X QC	4
B	1.5" TC Clamp	14
C	1.5" TC Gasket	14
D	1.5" TC Butterfly Valve	4
E	Spike+ Pickup Tube - Side	1
F	1.5" TC HERMS Fitting	2
G	Spike+ Pickup Tube - Shorty	1
H	HERMS Coil	1
I	1.5" TC Element	1
J	1.5" TC Temp Sensor	1
K	Compression Seal	2
L	Nut	2

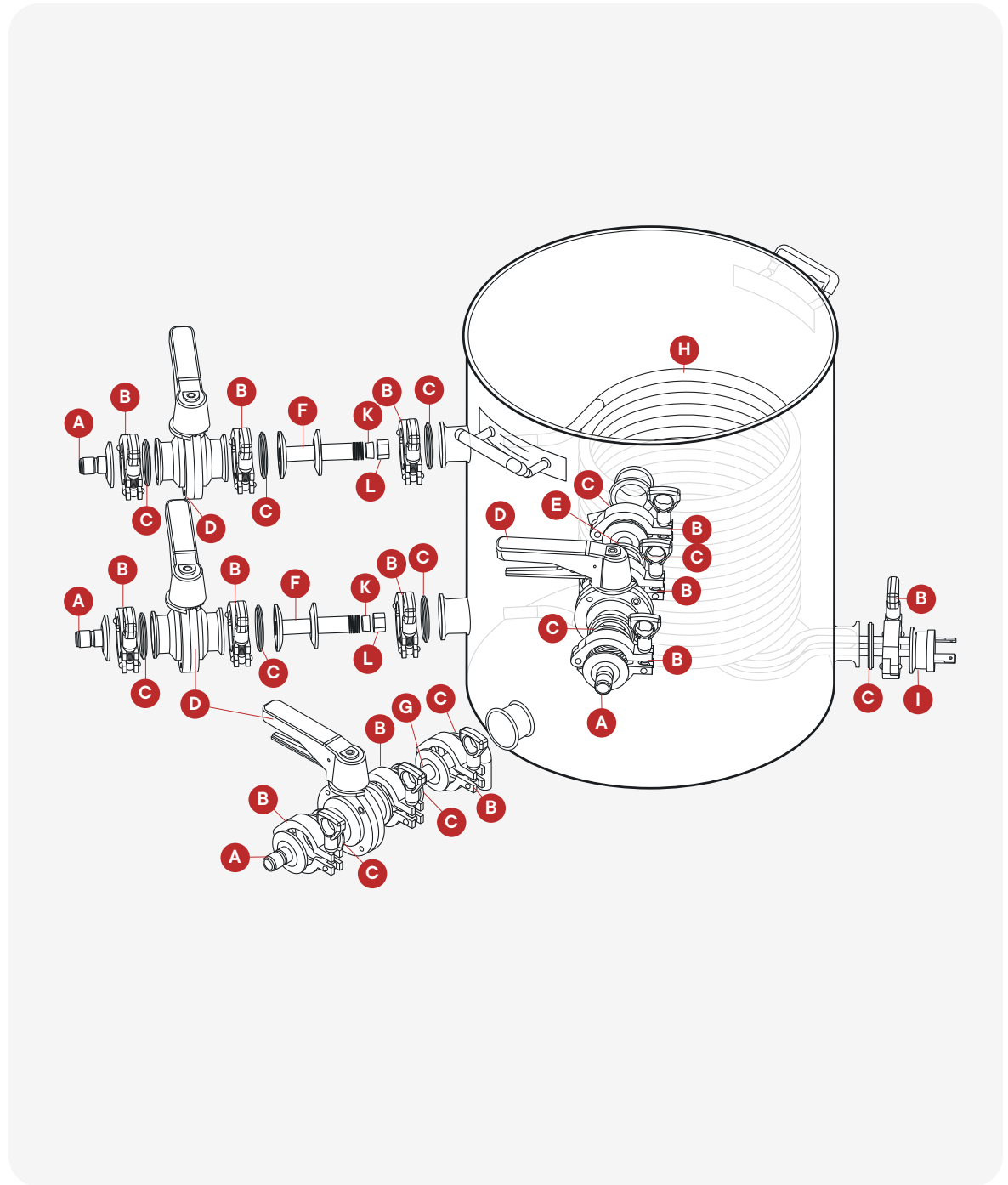

Assembly – HERMS Coil

Installing the HERMS Coil

1. Attach the TC HERMS fittings to the HERMS In and Out ports with a clamp and gasket.
2. Insert a Compression Seal (smaller end first) into the top HERMS fitting. (Wort Out Port).

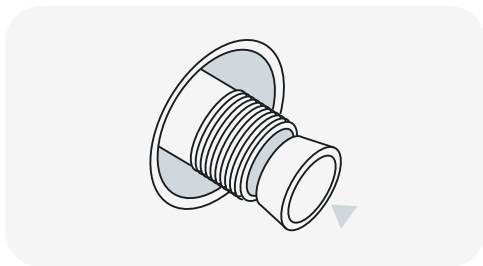

3. Slide the nut on to end of the HERMS coil tubing.

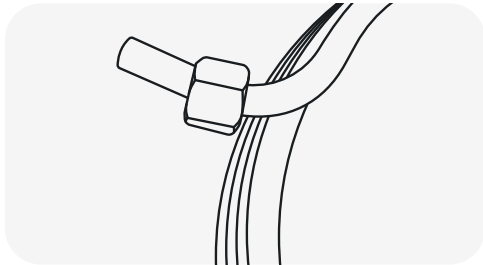

4. Insert the top of the HERMS coil into the Compression Seal.

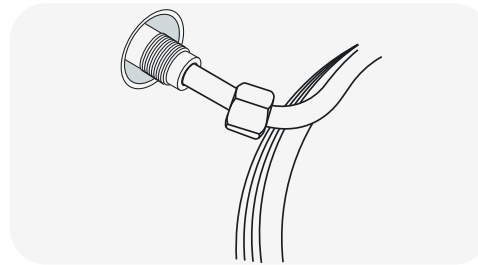

5. Slide the nut down and thread it on to the TC HERMS fitting as far as possible by hand. Use your other hand to support the weight of the HERMS Coil to make installation easier.
Note: Teflon tape is not needed for these threads.

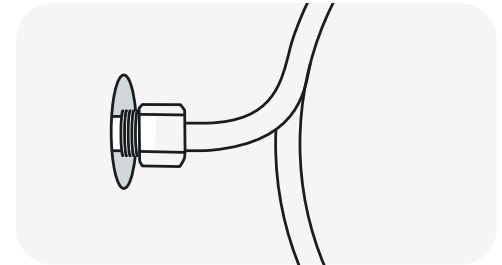

6. Use a wrench to further tighten the nut. An 8" adjustable wrench or a 15/16" wrench works well.
7. Repeat steps 4-6 on the Wort In (lower) port.

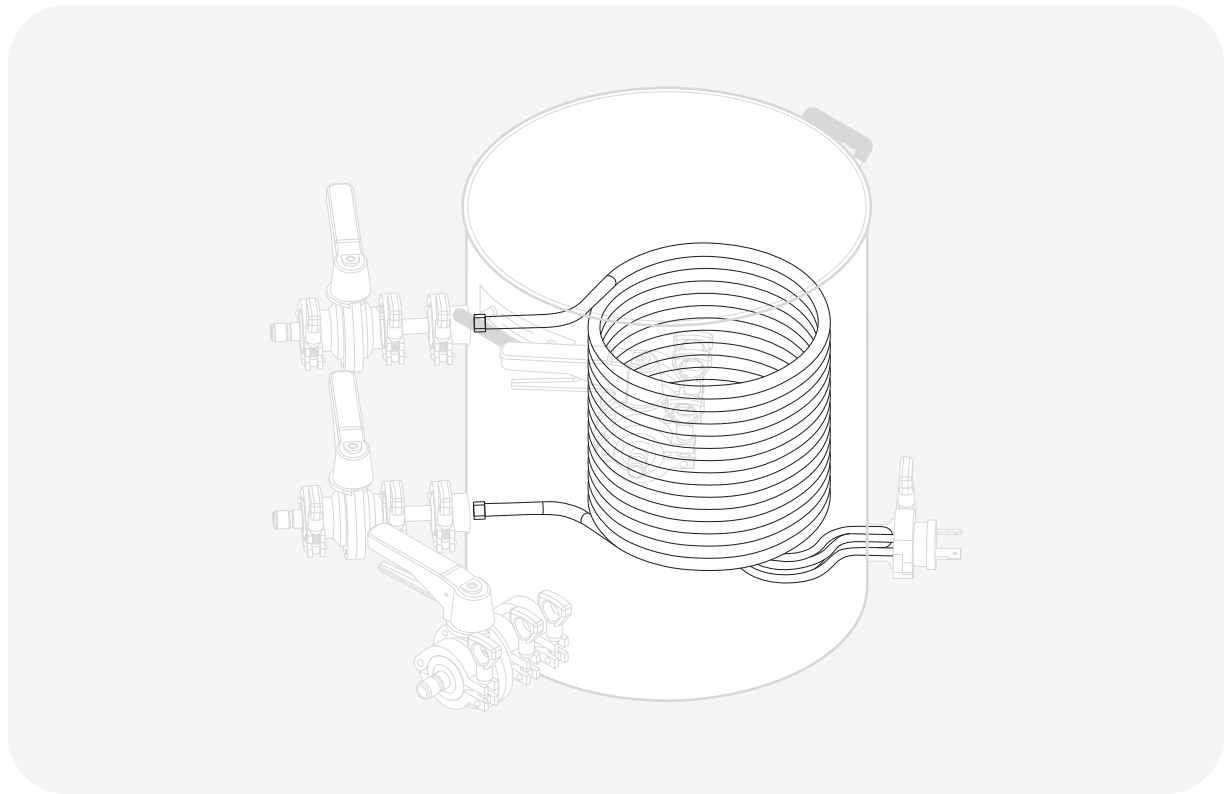

Assembly – Mash Tun

Use 2 feet of your silicone tubing to create a sparge arm from the top recirc port. The tubing will float on top of the grain bed allowing for an even recirculation.

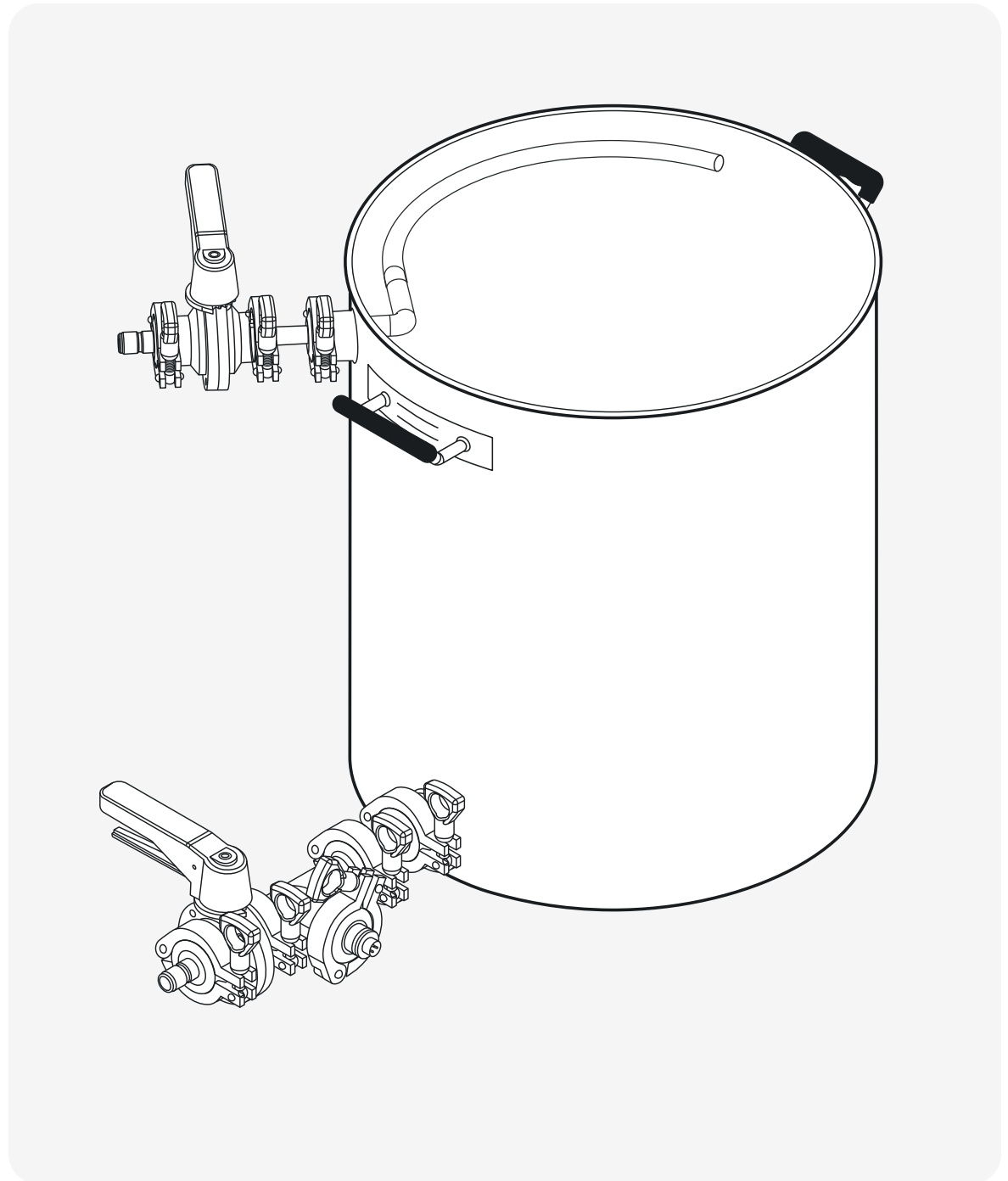

Assembly – Mash Tun

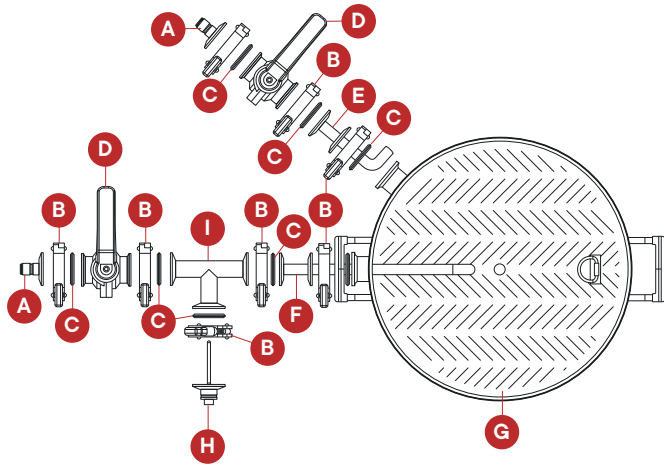

ITEM	DESCRIPTION	QTY
A	1.5" TC X QC	2
B	1.5" TC Clamp	8
C	1.5" TC Gasket	8
D	1.5" TC Butterfly Valve	2
E	Spike+ Pickup Tube - Side	1
F	Spike+ Pickup Tube - Center	1
G	False Bottom	1
H	1.5" TC Temp Sensor	1
I	1" TC Tee	1

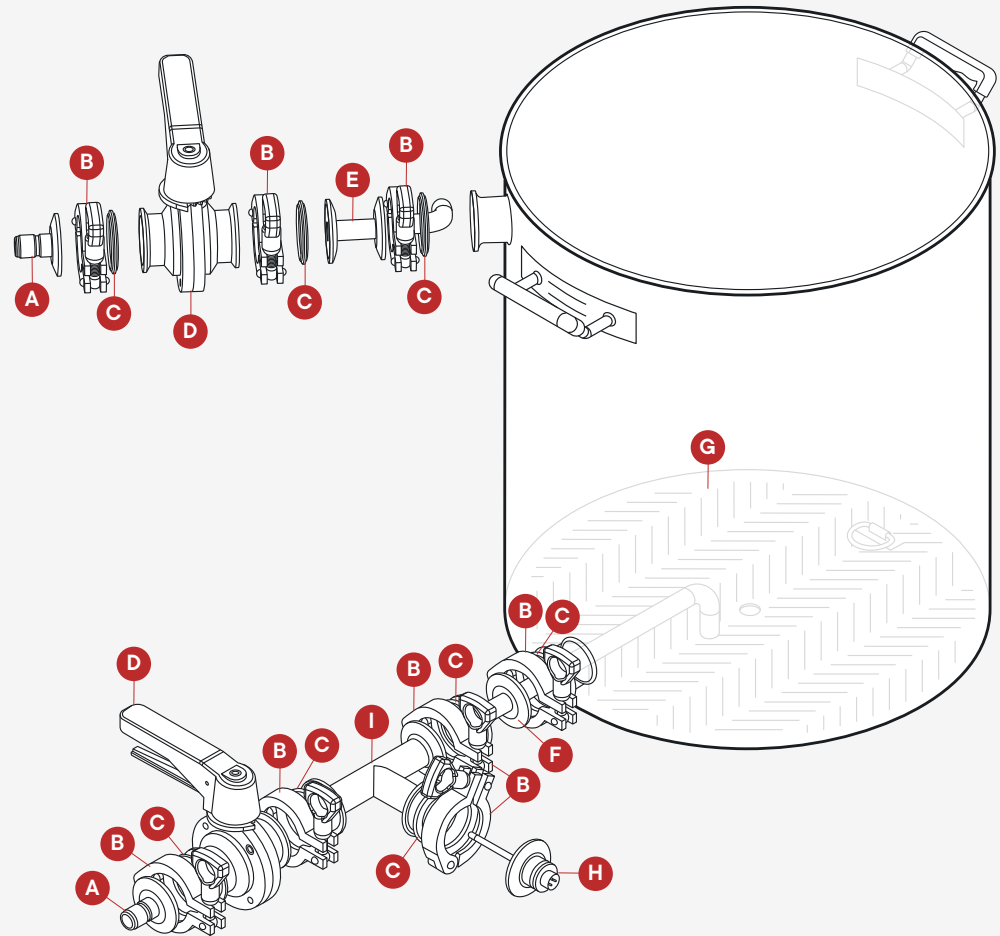

Assembly – Boil Kettle

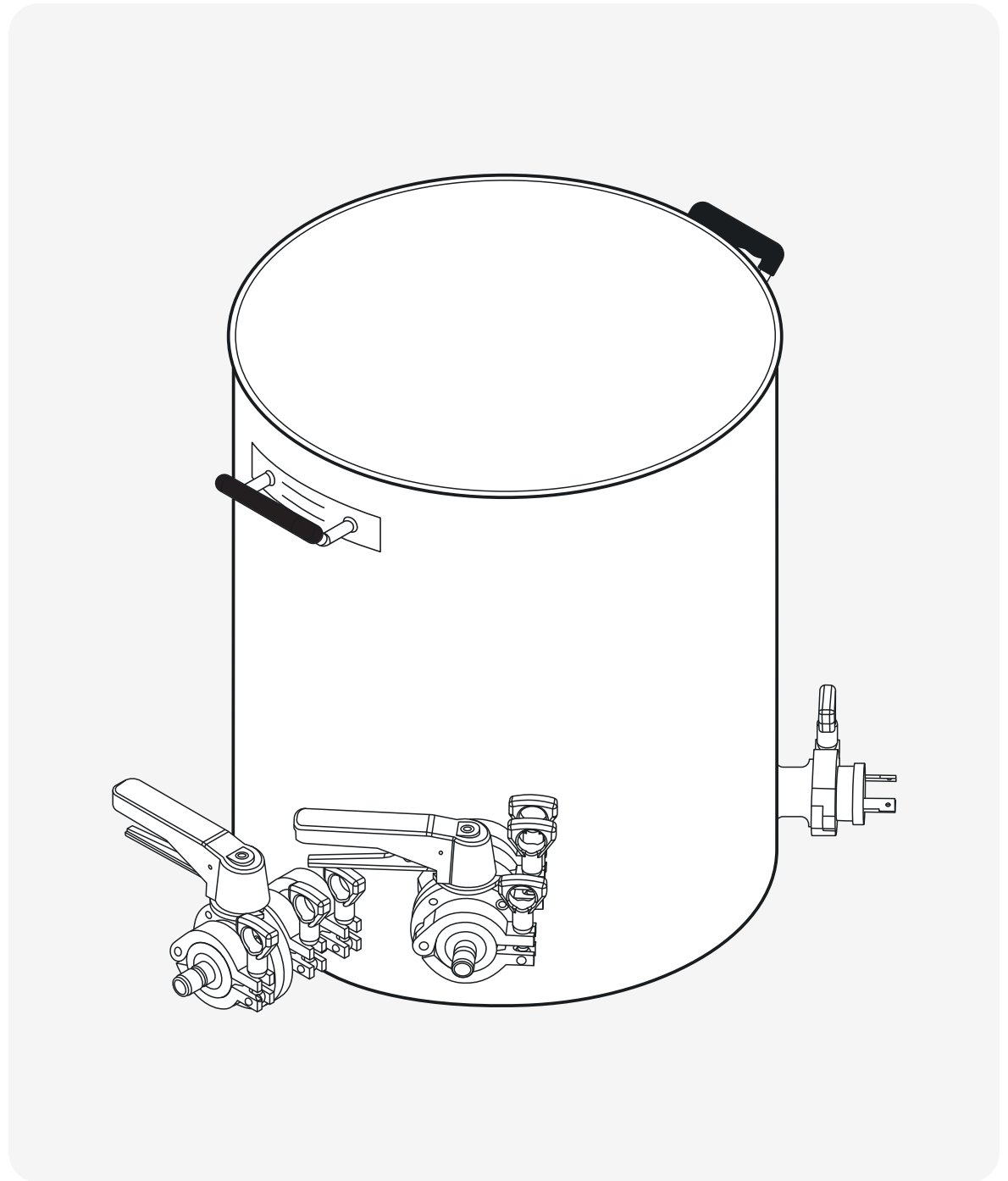

Assembly – Boil Kettle

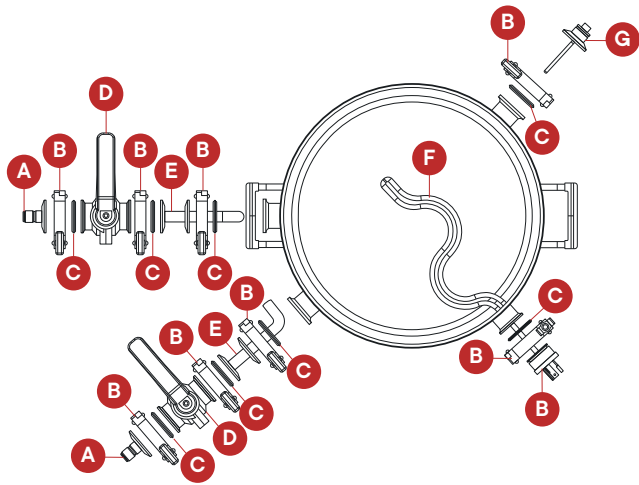

ITEM	DESCRIPTION	QTY
A	1.5" TC X QC	2
B	1.5" TC Clamp	8
C	1.5" TC Gasket	8
D	1.5" TC Butterfly Valve	2
E	Spike+ Pickup Tube - Side	2
F	1.5" TC Element	1
G	1.5" TC Temp Sensor	1

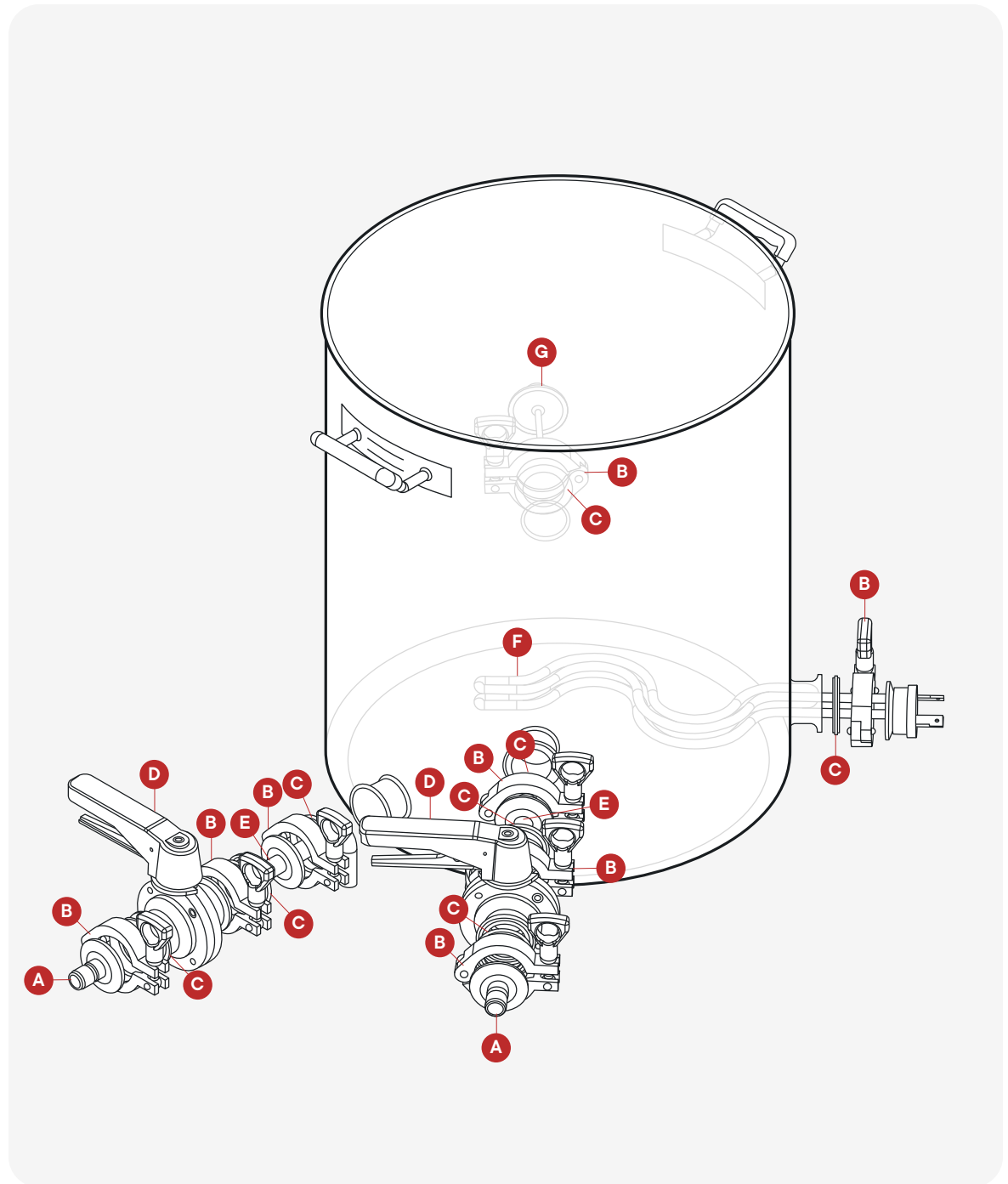

Assembly –

Steam Condenser Lid

The Steam Condenser Lid is placed on the Boil Kettle during the boiling step. Follow the process portion of this guide for specific operating instructions.

NOTE:

Make sure you keep the drain hose above the water line if using a bucket for drainage. Failure to do so will cause back pressure and system issues.

NOTE:

Water from drain hose will be warm. This can be collected and used for cleaning or reused for recirculation which cuts down on water usage. The water can be recirculated until it's about 120F or until it becomes too hot to touch. Starting with ice in the drain bucket can increase the amount of time the recirculation water can be used for until it gets too hot.



Assembly – Steam Condenser Lid

ITEM	DESCRIPTION	QTY
A	Condenser Lid	1
B	1.5" TC Clamp	4
C	1.5" TC Gasket	4
D	1.5" TC Cap	1
E	Condenser Piping	1
F	90° Barb	1
G	Condenser Mister	1
H	4" TC Clamp	1
I	4" TC Gasket	1
J	4" TC Clear Cap	1
K	1.5" TC Barb - 3/4"	1
L	Drain Hose	1
M	Supply Hose	1
N	Water Pump	1

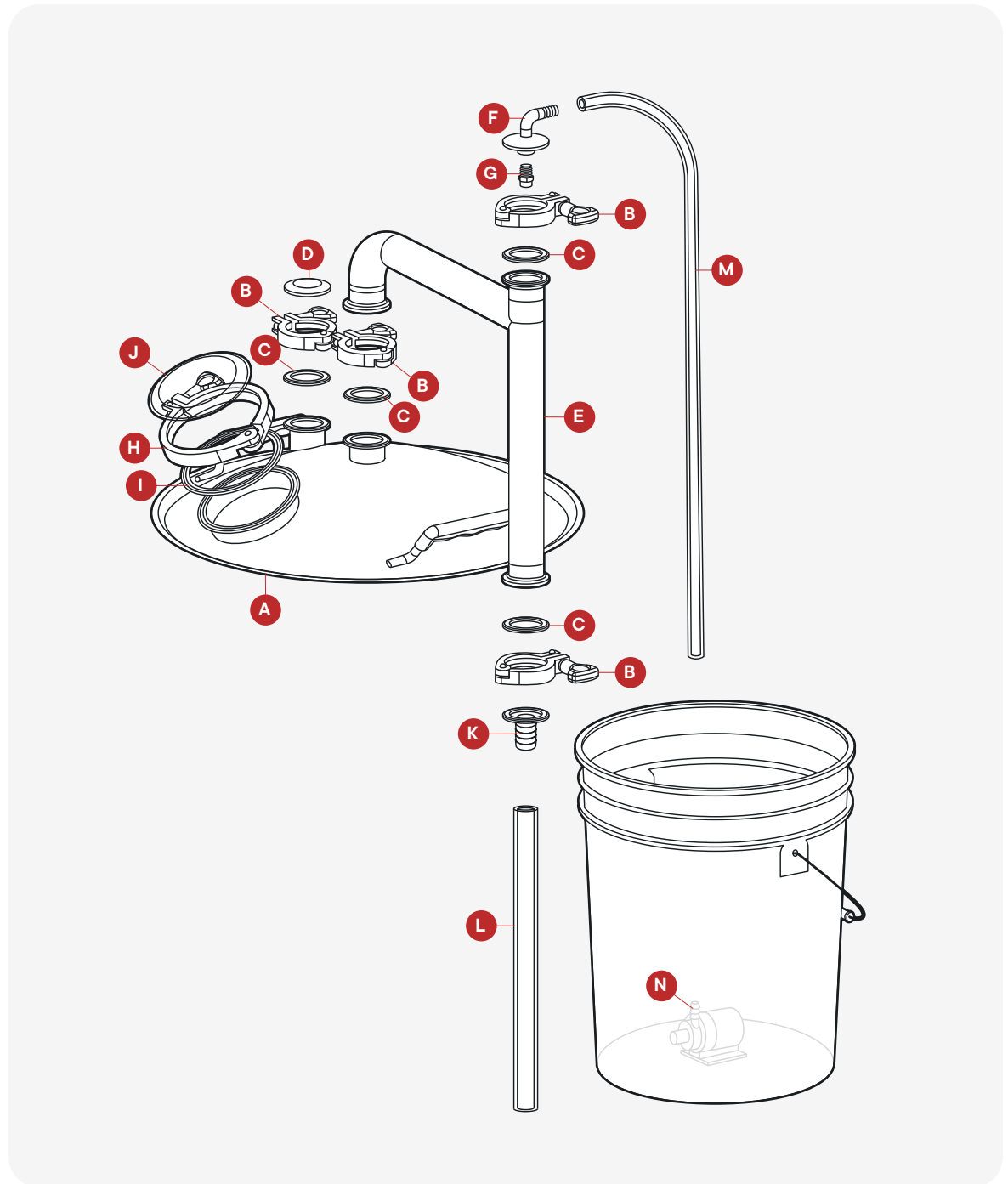

Assembly – Wort Chiller

Our counterflow chiller is made from stainless steel and lined with super-conductive copper, which provides fast chilling speeds. The chiller comes with QC fittings, so you can quickly connect to the rest of your system. It also includes a tee fitting and additional temp probe so you can monitor the inline chilling temps going into your fermenter.

To get started, attach the temp probe cable from your mash tun to the tee on the chiller. You'll be able to see the chiller exit temp on the control panel and adjust the flow rate to achieve your perfect yeast pitch temp.

If you have high groundwater temps, we recommend submerging your chiller in an ice water bath for the last leg of chilling.

The hot water exiting the counterflow chiller can be saved and reused for cleaning!

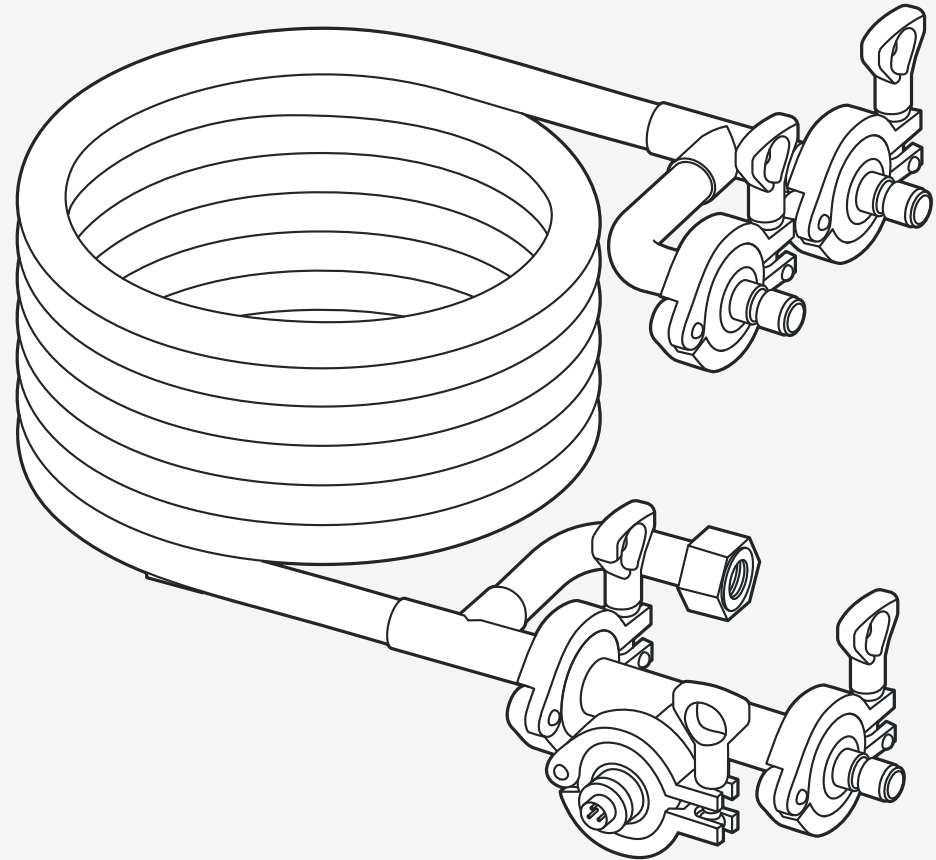

Assembly – Wort Chiller

ITEM	DESCRIPTION	QTY
A	Wort Chiller	1
B	1.5" Gasket	5
C	1.5" Clamp	5
D	1.5" TC x QC	3
E	1" TC Tee	1
F	Temp Probe	1
G	Hose Gasket	1

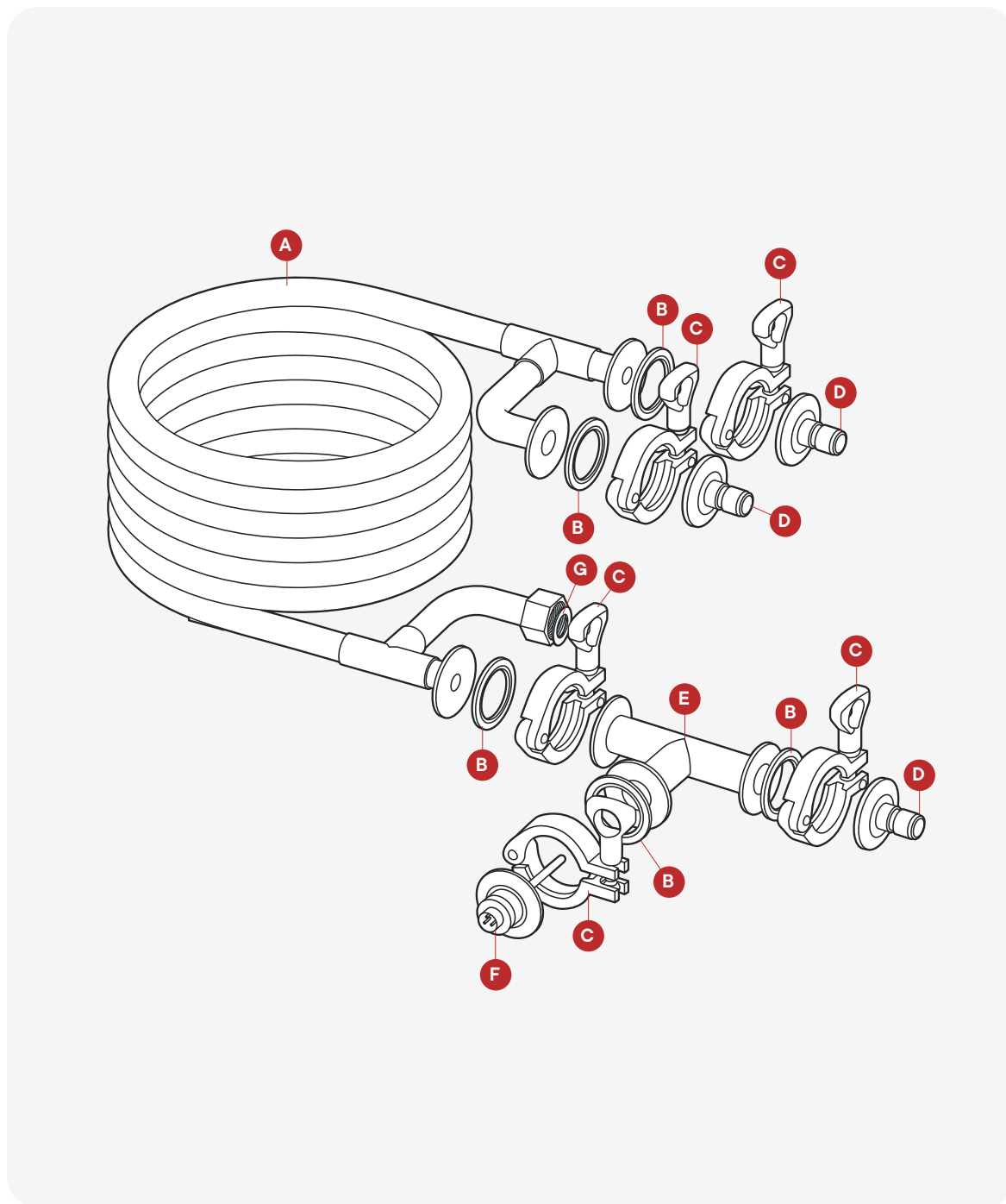

Assembly – Tables

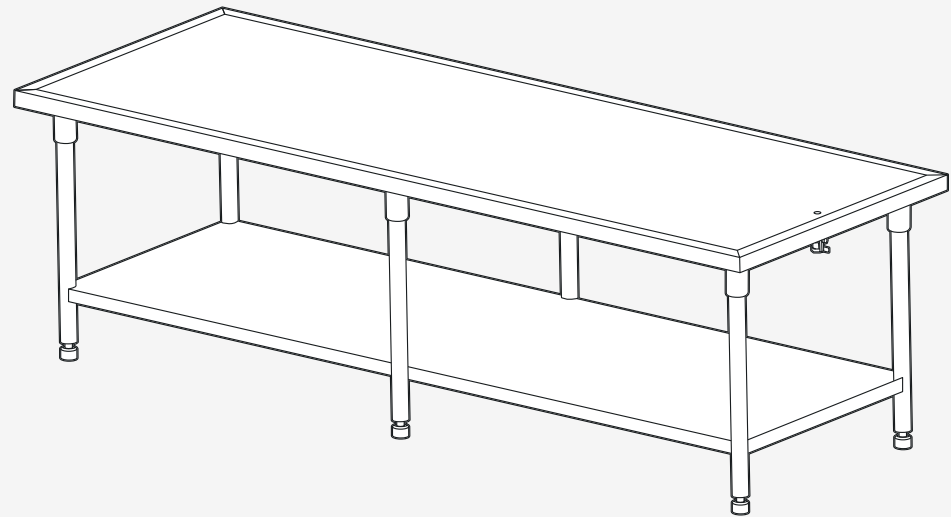

Assembly – 72” Table (15 & 20G Systems)

ITEM	DESCRIPTION	QTY
A	Tabletop	1
B	Shelf	1
C	Legs	4
D	Short Bolt	32
E	Washer	36
F	Split Lock Washer	36
G	Long Bolt	4
H	Pump Brackets	2
I	Allen Wrench	1
J	Drain Valve	1
K	Feet	4
L	Pump Mounts	2
M	Pump Nuts	8

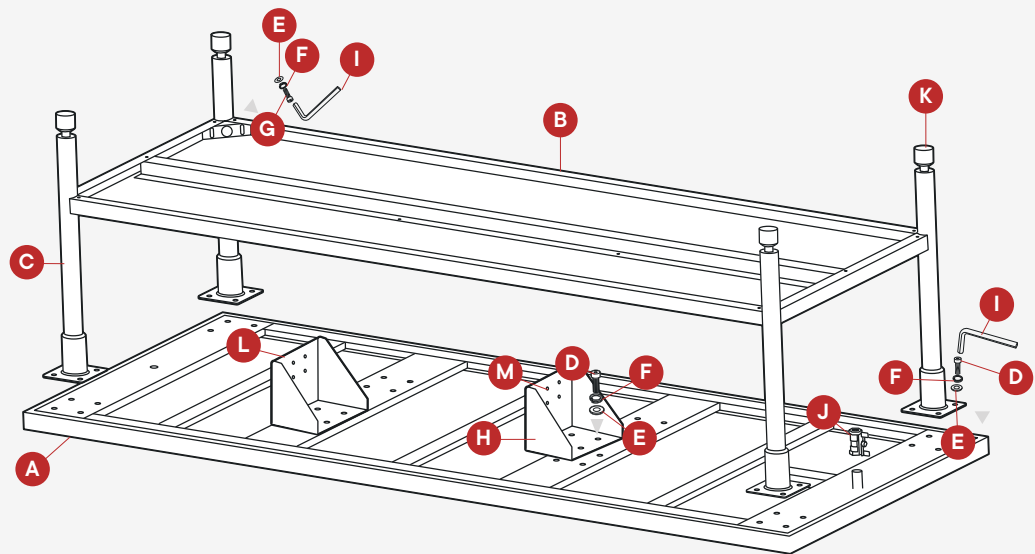

Assembly – 84” Table (30 & 50G Systems)

ITEM	DESCRIPTION	QTY
A	Tabletop	1
B	Shelf	1
C	Legs	6
D	Short Bolt	40
E	Washer	46
F	Split Lock Washer	46
G	Long Bolt	6
H	Pump Brackets	2
I	Allen Wrench	1
J	Drain Valve	1
K	Feet	6
L	Pump Mounts	2
M	Pump Nuts	8

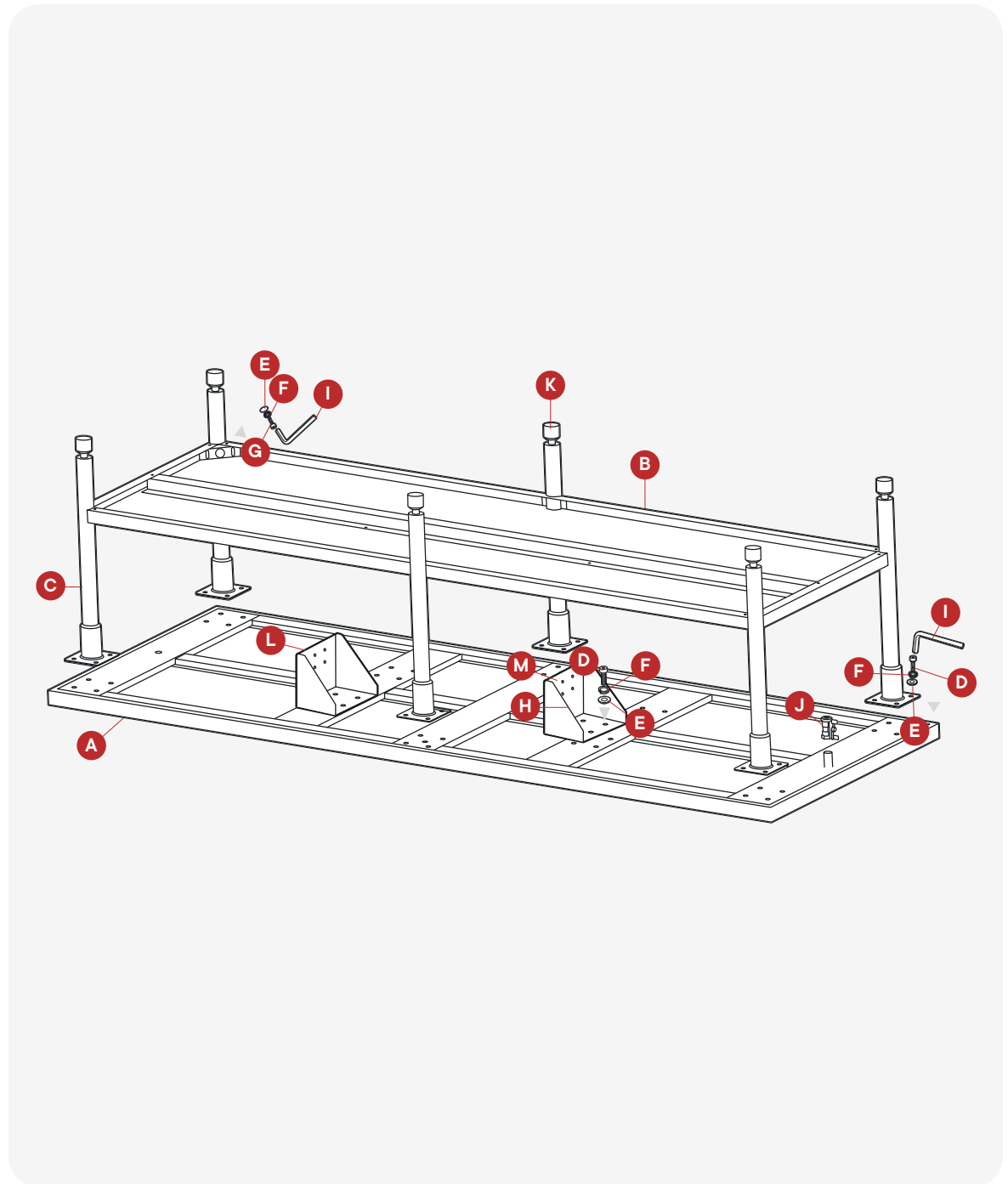

Assembly – Table

Assembling the table

1. Place the Tabletop upside down.
2. Line up each leg with the 4 corners of the table. For the 84" table, also align the 2 middle legs
3. Use the Allen Wrench to screw 4 short bolts to attach legs. Be sure to use a Washer and Split Lock Washer with each bolt.

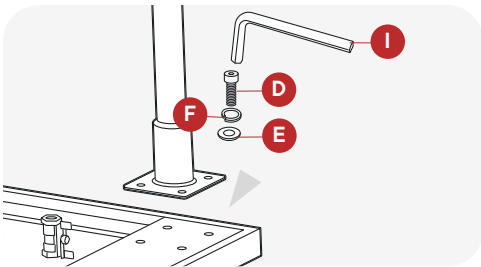

4. Line up each Pump Mount with the holes on the underside of the Table Top.

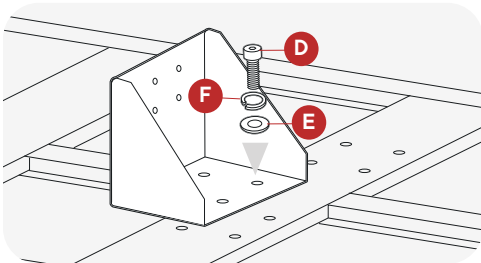

5. Use 4 Short Bolts, Washers, and Split Lock Washers to attach each mount to the table
6. Insert the Shelf through the legs until they align with the holes in the legs (if the Bolts are pre-installed on the legs, remove them prior to inserting the Shelf)
7. At each leg, use one Long Bolt, Washer, and Split Lock Washer to secure the Shelf. (These are visuals for you of the hole in the shelf and the bolt and hole in the leg. Bolt goes through the shelf and into the leg.)

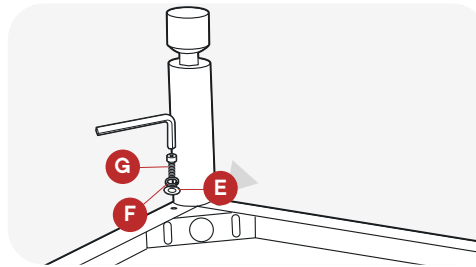

8. Install the Leveling Feet by first tightening the nut directly on top of the foot to secure it.

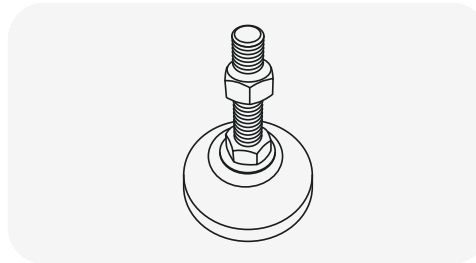

9. Thread the foot into the leg then tight the other nut on to the leg. Repeat this for the other legs
10. If needed, adjust how far the foot is threaded into the leg to make the table level

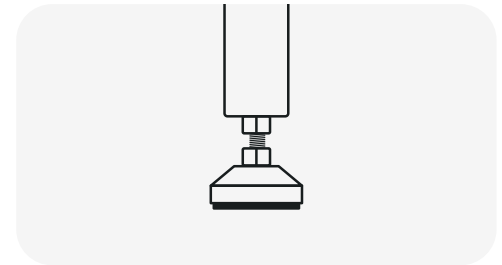

11. Screw the Drain Valve into the Drain in the table.
12. Turn your table over and it is now ready to use!

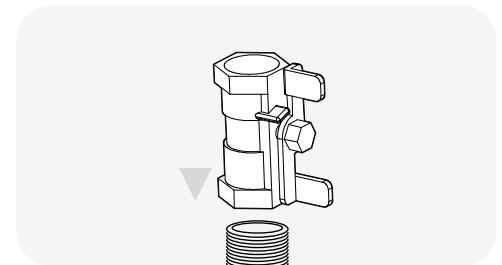

Assembly – Pumps

NOTE:

If you are using the optional table from Spike, it includes a mounting bracket for each pump. Attach the top of the mounts into the table then attach the pumps to the mounts with the included screws

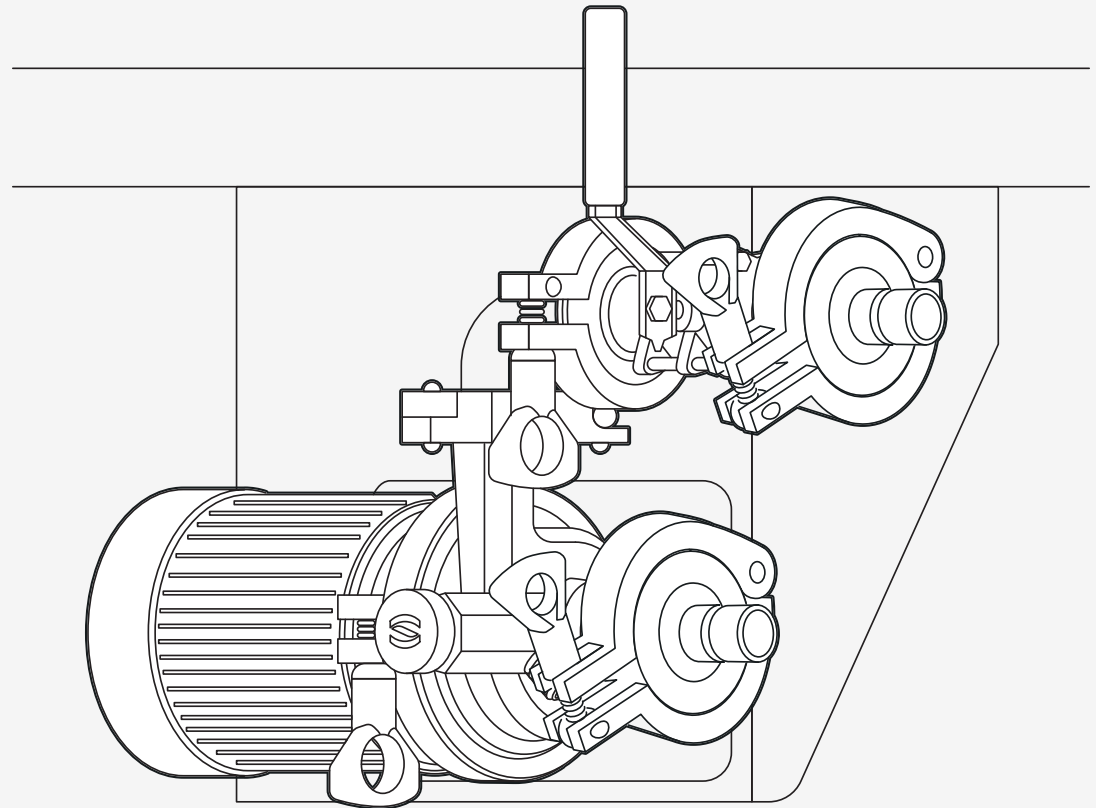

Assembly – Pumps

ITEM	DESCRIPTION	QTY
A	Spike Flow Pump	2
B	90° Elbow	2
C	1.5" TC Clamp	8
D	1.5" TC Gasket	8
E	1.5" TC X QC	4
F	Pump Brackets (included with optional table)	2
G	3 Piece TC Ball Valve	2

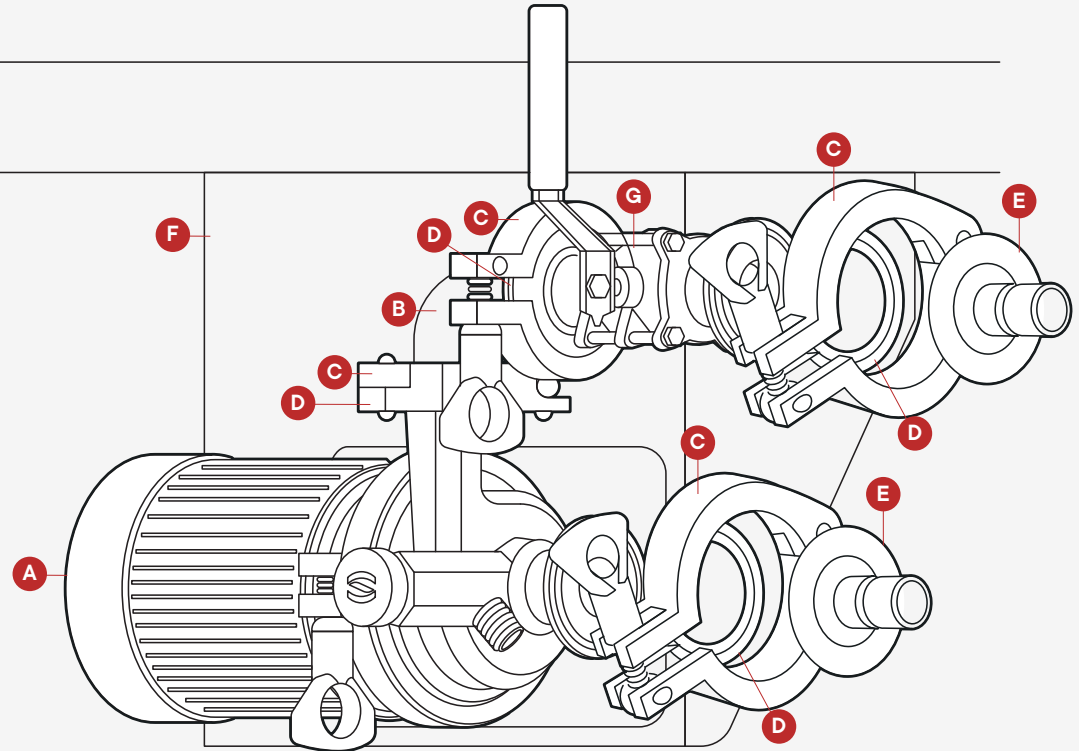

Assembly – Hoses

We use oversized barbs, which creates a secure attachment without the need for sharp hose clamps. The quick connect fittings also use a full port design which doesn't restrict the flow through the fitting resulting in a quicker brew day.

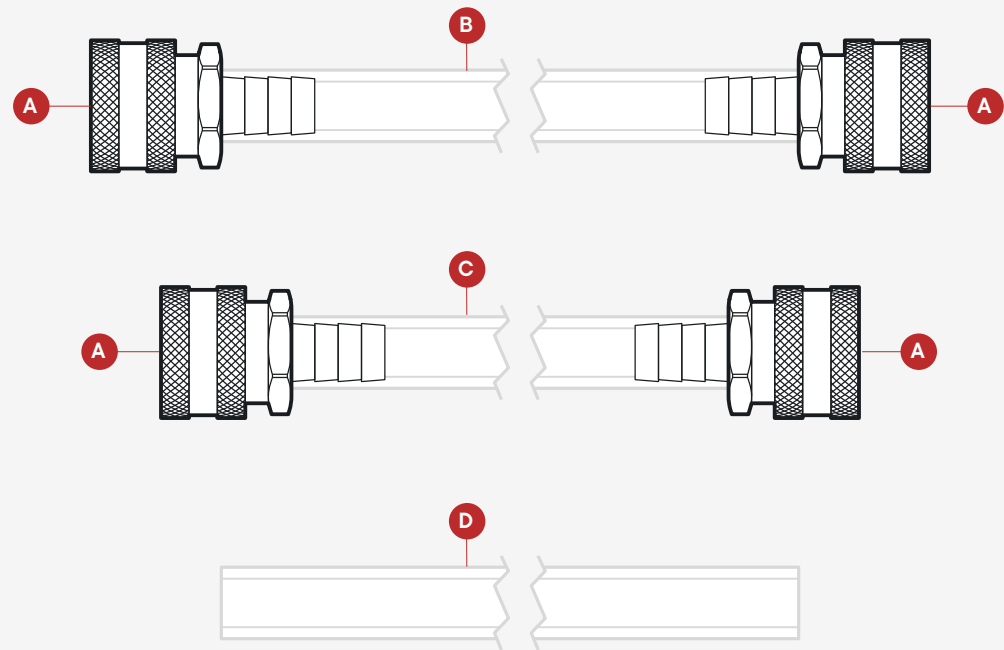

ITEM	DESCRIPTION	QTY
A	FQC x Barb	10
B	Long Hose – 6'	2
C	Short Hose – 4'	3
D	Mash Tun Recirculation Hose – 2'	1

Brew Day Guide

Now that your Trio is fully assembled, it's time to get brewing.
Follow the steps in this user guide for a simple and easy Brew Day experience.

Autotune the Control Panel

Set Up

Mashing

Sparging

Boiling

Using the Steam Condenser Lid

Whirl Pool

Drain to Conical

Using Your Trio Control Panel

Autotune the Control Panel

Before you get started, make sure to auto-tune your HLT PID controller. This ensures proper system calculations and helps the heating element run as efficiently as possible.

NOTE: you only need to auto-tune your HLT PID before your first brew

1. Fill your HLT 75% full with water.
2. On the PID, press the up arrow until you hit 150 degrees Fahrenheit.
3. Press **set** to lock in the temperature at 150F.
4. Turn the HLT element switch on to start heating your water to 150F.
5. Once water reaches 150F, press **set** and **<** at the same time.
6. Press **^** three times, then **<** once, then **^** three times to show 0033. Press **set**.
7. This will bring up F00.

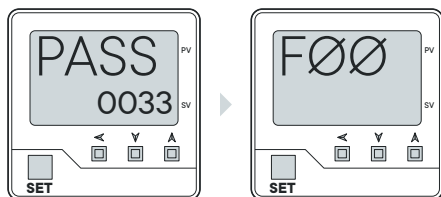

8. Press **^** two times to get F02, and hit **set**.
9. The screen will read AT (Auto Tune) on top with "no" in green at the bottom of the screen.
10. Press **^** to change from "no" to "yes".

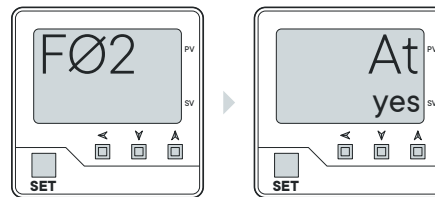

11. Press **set** and **<** at the same time.
12. "ATU" will blink on the bottom left of the screen.
13. Auto Tuning can take up to an hour as the PID makes adjustments. Auto Tuning is complete when "ATU" stops blinking!

Controlling Your Boil

Ready to boil? The PID has 2 temperature control options, Auto and Manual. Auto allows you to set a specific temperature, and the heating element will hold the liquid at that temperature. Manual mode will allow us to control heating output by percentage instead of actual temperature. This works similar to dialing your gas burner up or down, but on a numeric scale of 0-100.

We recommend moving your Boil PID to Manual mode, and keeping it in that mode at all times. To move from Auto to Manual, follow the steps below.

1. Start on the temperature readout screen, and press **set** until you see AMRS.
2. Press up to change from Auto to Manual, and press **set** again.

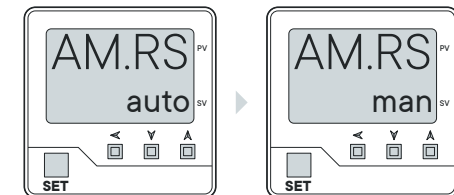

3. Click **set** twice to bring you to the Manual temp screen, and set your temperature.

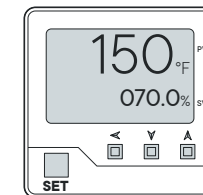

To begin your boil, make sure your elements are completely covered in liquid. We recommend setting the temperature to 100% output until you are at boil, then dial down to 70-80% for the duration of your boil.

Brew Day – Set Up

Follow these steps to get your Trio ready to roll on Brew Day.

1. Make sure all valves are closed.
2. Place your false bottom in your mash tun and connect the pickup tube.

3. Set up the hoses (see **Figure 1**):
Connect a 6 ft. hose from the Mash Tun (MT) drain to the wort pump inlet (**Gold**)

Connect a 6 ft. hose from the wort pump outlet to Hot Liquor Tank (HLT) bottom HERMs port (**Green**).

Connect a 4 ft. hose from the HLT HERMs outlet to mash tun top recirculation port (**Red**).

Connect a 4 ft. hose from the drain of the HLT to the water pump inlet (**Blue**).

Connect a 4 ft. hose from the water pump outlet to the HLT top recirculation port (**Black**).

PRO TIP: The water pump is only used to pump clean water and therefore doesn't need cleaning at the end of your Brew Day

4. Determine the appropriate amount of strike water for your specific recipe and fill the mash tun.

Figure 1

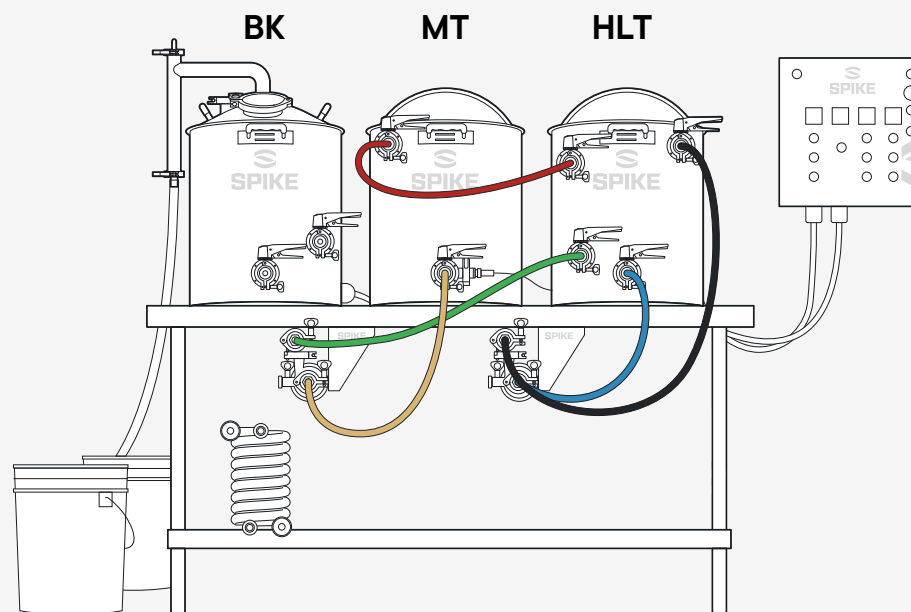

PRO TIP: Make sure to consider the dead space under the false bottom and your HERMs coil when filling your mash tun. If you don't account for this space by adding more water, your mash may end up a little thicker than desired.

5. Fill the HLT so your HERMs coil is covered (~75% full).
6. Set your HLT roughly 10 degrees hotter than your desired mash temp using the HLT controller (When you mash in this will drop your strike water temp down to your desired mash temp).

7. Turn the HLT element on.
8. Put the lid on your HLT.

PRO TIP: Once your strike water and HLT are warmed up, you can adjust your water chemistry by adding minerals.

9. Put the lid on the MT.

Continued on next page.

Brew Day – Set Up

10. As shown in **Figure 2:**

- Open your top recirculation MT valve (A)
- Open the MT drain valve (B)
- Open the HLT drain valve (C)
- Open both HLT HERMs ports (D and E)
- Open the top recirc port (F)

- 11.** Bleed the air from the lines of the system by opening the Air Release Valve (ARV) until a steady stream of liquid comes out.
- 12.** Open the outlet valves on each of the pumps.
- 13.** Turn on your water pump (You can run the water pump wide open at this time).
- 14.** Turn on your wort pump. (Feel free to run the wort pump wide open while heating the mash tun).
- 15.** Watch your MT PID until it gets to your desired strike temp.

PRO TIP: The MT PID is a readout only. The MT temp is controlled by the HLT via the HERMS coil. To increase the MT temp, increase the HLT temp. Set the HLT a few degrees hotter than your desired MT temperature to account for hose temperature loss.

Figure 2

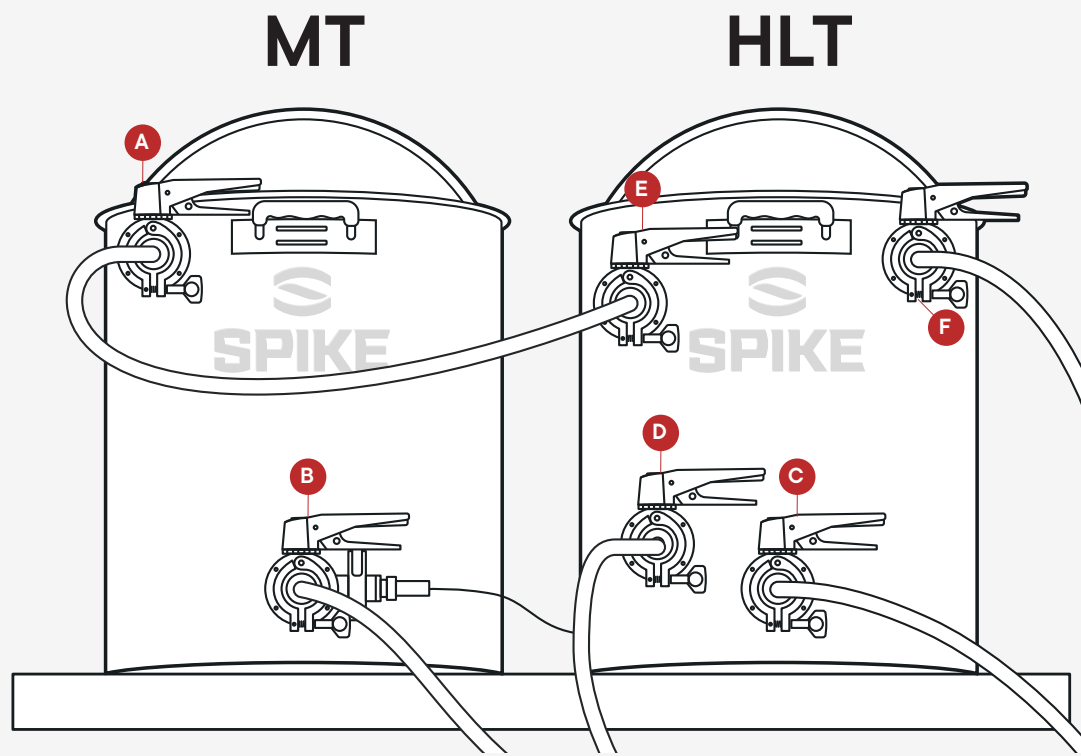

- 16.** Turn off the wort pump in preparation for mashing in.

PRO TIP: Need to bring your mash temp down a bit? Try adding some cold water to the HLT.

Brew Day – Mashing

After setting up, it's time to mash in.

Since the Spike System uses a constantly recirculating mash technique, you'll only need to mash for 30–45 minutes until starch fully converts to sugar.

There's also no need to Vorlauf (a pretty awesome German word but, in this case, an unnecessary step). Bypassing this process will save you about 20 minutes on Brew Day.

1. Ensure your hoses are properly set up (see **Figure 3**).
2. Slowly add your grain while constantly stirring to avoid any dough balls. This will drop your strike water down to your desired mash temp.
3. Turn the wort pump back on to recirculate the mash through the HERMS Coil. Throttle the flow of the MT recirculation port to a 25% flow rate to prevent grain bed compaction.
4. Continuously recirculate the mash until all starches have been converted to sugars.

Figure 3

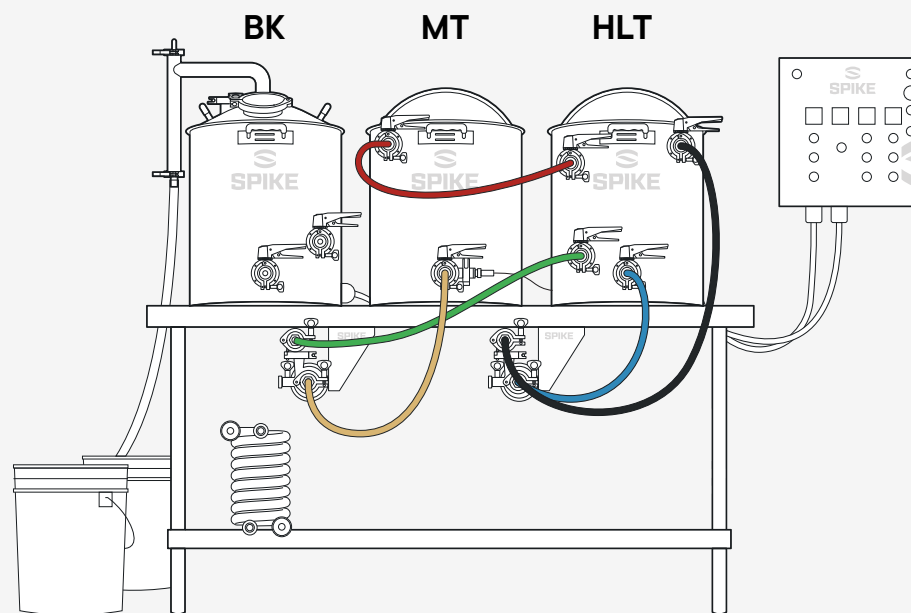

PRO TIP: When reducing flow, always throttle the ball valve on the pump - not the butterfly valves on the kettle. Throttling the ball valve gives the best control and prevents cavitation and any possible pump damage.

PRO TIP: If you would like to 'mash out,' you can turn the HLT up to roughly 175°F during the last 10 minutes of mashing. This will allow for mashing out at 170°F.

Brew Day – Sparging

Now it's time to rinse your mash grains, which will help you maximize the amount of sugar available from the mash process.

1. When your mash is complete, turn off the pumps and close all the valves.
2. Connect two feet of silicone tubing to the side pickup of the mash tun. The tubing will float on top of the grain bed, allowing for even recirculation.
3. Move the hose attached to the inlet of the HERMS port to the Boil Kettle (BK) whirlpool port (**Green**).
4. Move the hose attached to the HLT top recirculation port down to the newly vacated inlet of the HERMS

PRO TIP: Pumping hot water through your HERMS coil clears out any wort while also cleaning out the inside.

port (**Black**).

5. Open the HLT drain valve and the HERMS inlet and outlet valves.
6. Purge the water pump.
7. Turn on water pump and open the valve.

Figure 4

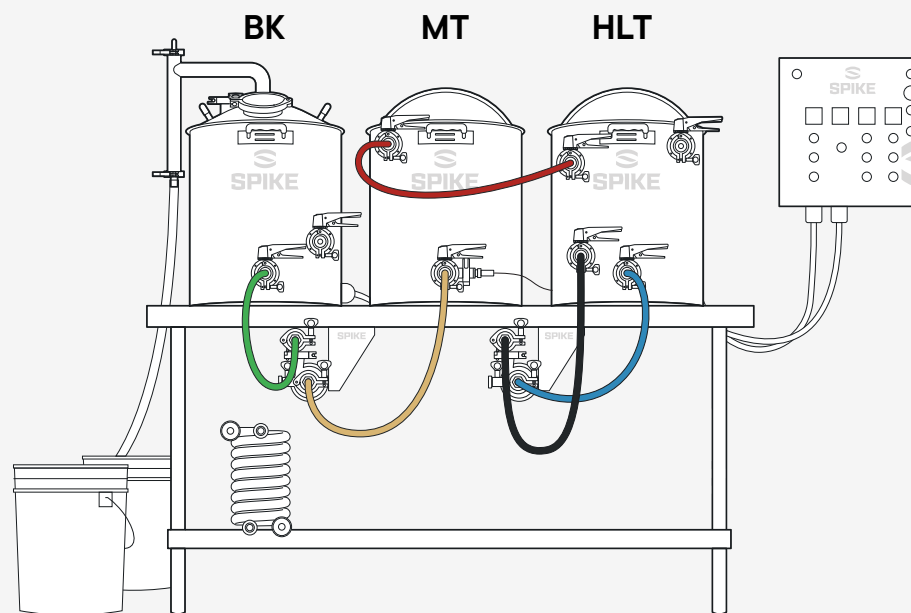

8. Slowly open the MT top recirculation valve until you see a small trickle of water over the grain bed.
9. Leave an inch or two of water over the grain bed. This will naturally disperse your sparge water over the grain bed. As your sparge water trickles through the grain bed, it will wash the sugars from the grain into the boil kettle.
10. Open your MT drain valve.
11. Crack open the whirlpool port valve on the BK.
12. Purge the wort pump.
13. Turn your wort pump on.
14. Slowly drain the wort from the MT to the BK.
15. Equalize the sparge in and wort out of the boil kettle by matching sparge and MT drain flows. Keep both down to a trickle.

PRO TIP: Once the wort level is above the element in the BK, turn on the BK element. This will allow your BK to be near-boil by the time you finish your sparge, which helps shorten your Brew Day by about 30 minutes. We recommend the PID up to 100% power.

Brew Day – Using the Steam Condenser Lid

Built to transform steam into liquid during the boiling process, our steam condenser lid not only reduces your boil-off rate, it allows you to brew inside without worrying about moisture collecting on your walls or ceiling.

1. Assemble your Steam Condenser Lid as outlined on page 11.
2. Grab a 5 gallon or larger container to use as your pump reservoir.
3. Place the submersible pump into the reservoir and stick it to the bottom using the suction feet.
4. When getting ready to boil, fill the container with cold water.

PRO TIP: Leave the steam condenser lid off when approaching boil to avoid any boil over. Once the hot break has subsided, you can place the steam condenser lid on.

5. Run the condenser lid output hose into a floor drain or collection container.

6. Make sure that the exit hose isn't submerged underwater and can drip freely. If submerged, back pressure will force the steam out where the lid and kettle meet.

PRO TIP: Water from drain hose will be warm. This can be collected and used for cleaning or reused for recirculation which cuts down on water usage. The water can be recirculated until it's about 120F or until it becomes too hot to touch.

PRO TIP: If you hook up directly to your brewery's water source, you'll need to reduce the pressure to 6psi. Without making this adjustment, your flow rate will be too high and you'll waste plenty of water.

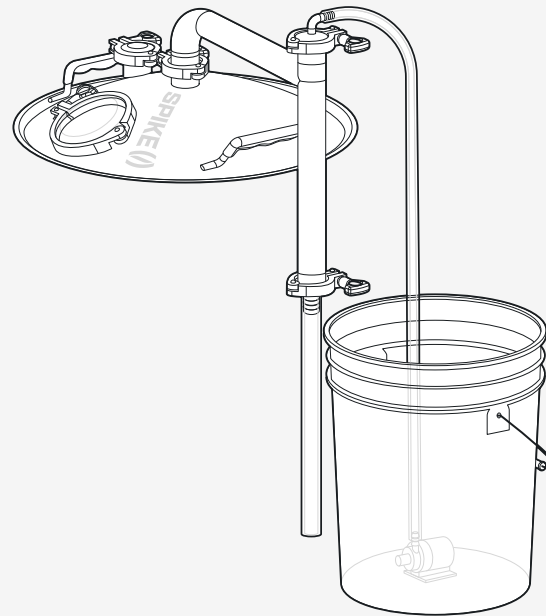

7. Turn on the submersible pump.
(Water will begin to flow from the reservoir container, go up through the misting nozzle, and through the top of the condenser piping. This process creates a vacuum by cooling the steam into a liquid. The liquid will then flow out of the bottom of the piping into your collection container.)
8. Boil for the duration of time required by your recipe.
9. Keep an eye on the steam condenser water reservoir so it doesn't run dry. As it empties, refill it with cold water.

PRO TIP: Once your brew day is complete, rinse out the kettle, dump any solids and add a CIP ball to the second 1.5" TC port in the lid.

Brew Day – Boiling

Follow these steps to keep things rolling during the boiling phase.

1. Make sure you have moved your Boil Kettle PID to Manual Mode. Please reference the manual on page 18 to move to Manual Mode.
2. Once you've reached your pre-boil volume, turn off the pumps and close the valves.
3. As you reach your boiling temp, you can adjust the power up or down to keep the perfect rolling boil and avoid boil overs. If you see a boil over happening, quickly turn off the element, stir down, or squirt the hot break material. When you turn the element back on, adjust the power to the appropriate level.
4. Add bittering hops and start your boil timer (if applicable)
5. Once the boil is completed, turn off your BK element.

PRO TIP: There should be about 3–4 gallons of water in your HLT. Turn your HLT element back on when your boil is complete and heat water to 170°F degrees. This water will be used to CIP the system after your brewing is done.

Brew Day – Whirlpool

Let's take that wort out for a spin.

Figure 5

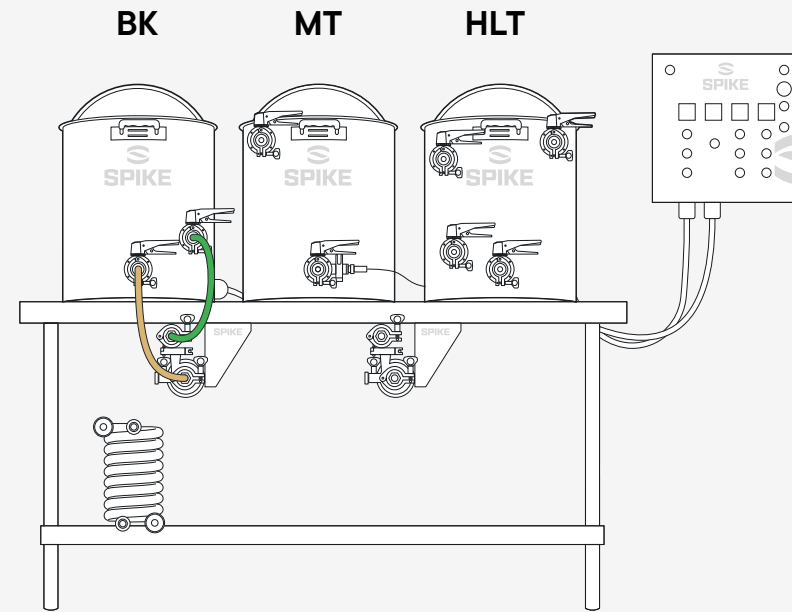

1. Move the hose from the outlet of the MT to the outlet of the BK. (**Gold**)
2. Open the drain and whirlpool valves on kettle.
3. Purge air in pump if needed.
4. Open the valve on wort pump.
5. Turn on the wort pump.
6. Whirlpool for 10–15 minutes to form a tight hop cone.
7. Turn off the wort pump.
8. Let the wort rest for 10–15 minutes.

Brew Day – Drain to Conical

Follow these steps to get ready for fermentation.

1. Grab your counterflow wort chiller,
2. Move your hose connected to the BK whirlpool port and connect it to the inlet of the wort chiller (wort side).
3. Connect a hose from the outlet of the wort chiller to your Spike Conical (wort side).
4. Connect a cold-water source to the inlet of the wort chiller (water side).
5. Connect a hose from the water outlet of your wort chiller into a drain (sink, floor drain, HLT, etc.) (water side).

PRO TIP: Water exiting the chiller will be hot. You can collect the first 3–4 gallons from the output of the chiller in your HLT and use CIP reducing your water usage.

6. Open your BK drain valve.
7. Purge your wort pump of air.

Figure 6

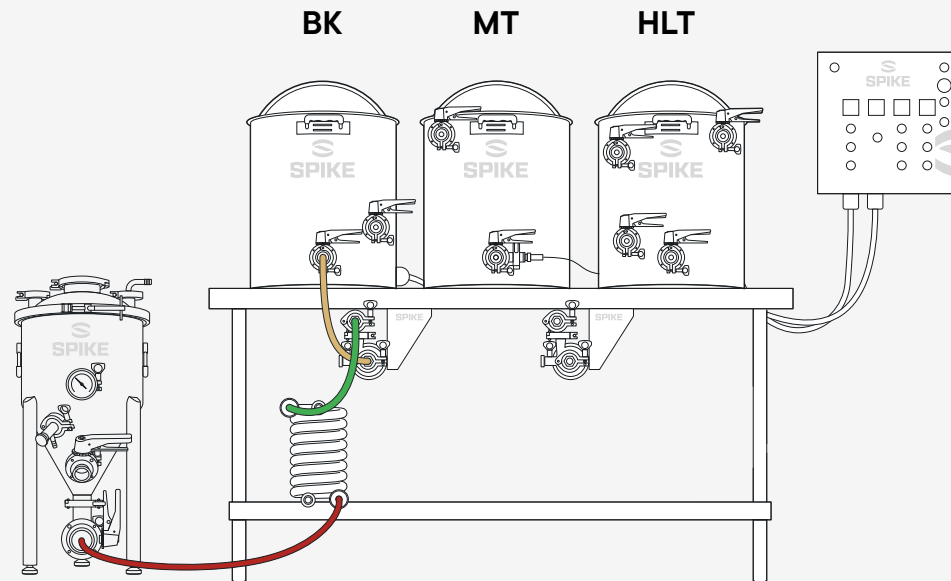

8. Monitor the temps of your water by moving your mash tun temp probe to the temp probe port of your wort chiller.
9. Turn on your wort pump.
10. Slowly open your wort pump until you see your desired yeast pitching temp on the MT PID readout.
11. Drain until BK is empty.
12. Turn off the wort pump and close all the valves.
13. Add yeast and seal your conical.

Brew Day – Cleaning (CIP)

Follow these steps to speed through the cleanup process and keep your equipment running smoothly for your next Brew Day.

1. Drain any wort left in your MT and hop material out of your BK.
2. Scoop or dump your grain out of the MT.
3. Rinse the MT and BK with a hose or water source.
4. Check that the HLT is holding at CIP temp of 150F.
5. Be sure to turn off your HLT element before starting your CIP.
6. Connect a 4 ft hose from the HLT drain port to the inlet of the wort pump.
7. Connect a 6 ft hose from the outlet of the wort pump to the top recirculation port of the MT. (see **Figure 7**)
8. Open the valves and turn on the wort pump until all the water from HLT is transferred into the MT (you don't need to clean HLT or water pump since it was only holding water during the brew.)

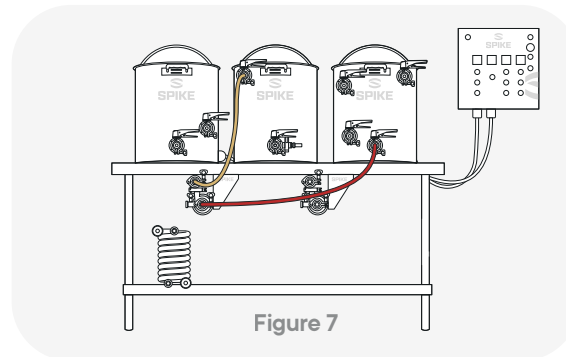

Figure 7

9. Close all the valves and turn off the wort pump.
10. Add your brewery wash chemicals to your MT.
11. Scrub the MT Down to remove any grain material from the sides of the kettle.
12. Disconnect the hose connected to the MT recirculation port, and connect it to the bottom HERMS Coil port.
13. Move the hose that was connected to the HLT drain port to connect the top HERMS Coil port and the MT recirculation port.
14. Add a 6 ft hose to connect the MT drain port and the wort pump inlet. (see **Figure 8**)
15. Open all the valves and turn on the wort pump.
16. Close and open all of the valves in this recirculation flow as the brewery wash is running through them. This helps clean the valve parts.

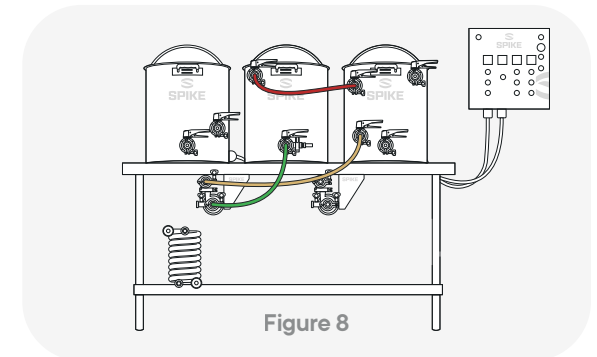

Figure 8

17. Close all valves and turn off the pump.
18. Keep your MT drain hose connected to the wort pump inlet. Move 6 ft hose from the wort pump outlet to the BK whirlpool port. (see **Figure 9**)
19. Open the valves and turn on the wort pump until all the water from the MT is transferred to the BK.

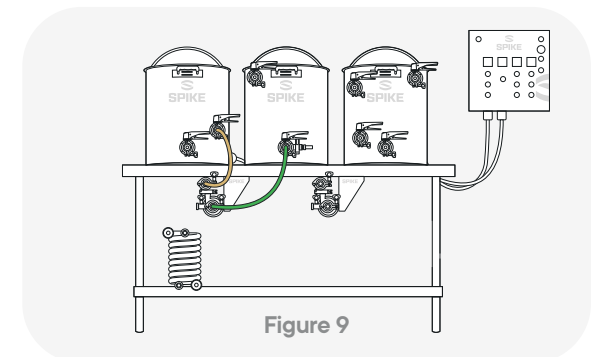

Figure 9

Continued on next page.

Brew Day – Cleaning (CIP)

Follow these steps to speed through the cleanup process and keep your equipment running smoothly for your next Brew Day.

1. Close all the valves and turn off the wort pump.
2. Connect a 6 ft hose from the outlet of the BK, to the inlet of the wort pump. (see **Figure 10**) Open the valves and turn on the wort pump.
3. Open the valves and turn on the wort pump.
4. Close and open all of the valves in this recirculation flow to push brewery wash through all ports.
5. Close all the valves and turn off the wort pump.
6. Connect the hose currently connected to your whirlpool port, to the outlet of the counterflow chiller. We are going to flush our counterflow chiller with brewery wash the reverse direction.
7. Connect a hose to the inlet of your counterflow chiller as a drain hose to your waste location. (see **Figure 11**)
8. Open all the valves and turn on the wort pump, draining your BK.
9. Add a few gallons of water to your MT. Rinse the system once more using clean water while following the steps above.
10. Once system is fully drained, leave all valves open so that it can dry out.
11. You can add Star San with your rinse water to rinse and sanitize at the same time.

