

# Spike Solo System

Bottom Drain User Guide



# Congrats on securing your new Spike Solo System!

We know you're anxious to get brewing, so we made these assembly instructions and Brew Day Guide easy for you to follow and threw in a few pro tips along the way.

Grab a beer, and let's get started.

<b>01. Assembly</b> .....	<b>2.</b>
Kettle.....	4.
Basket .....	6.
Assembled.....	8.
Table .....	10.
Wort Chiller.....	13.
Pump.....	15.
Hoses.....	17.
Panel.....	18.
<b>02. Brew Day Guide</b> .....	<b>19.</b>
Using the Control Panel .....	20.
Heat Strike Water.....	23.
Mashing .....	24.
Drain (Lauter) .....	25.
Boiling .....	26.
Whirlpool.....	27.
Chill (Knockout).....	28.
Cleaning .....	29.

01.

---

# Assembly

Ready to get your Solo up and running? This guide will show you how to assemble each piece of equipment with step-by-step instructions and key visuals.

**Kettle**

**Basket**

**Assembled**

**Wort Chiller**

**Pump**

**Hoses**

# Before you begin

Make sure the elements are plugged in, and the power cords are fully twisted into position. We also recommend strain relieving the power cords so the full weight is not pulling down on the element connection. Taking these actions will certainly extend the life of your power cords.

Before installing parts into quick-connect (QC) fittings, be sure to lubricate them with water. This will allow them to slide into the QC fitting easily and prevent tearing the o-ring.

# Assembly – Kettle

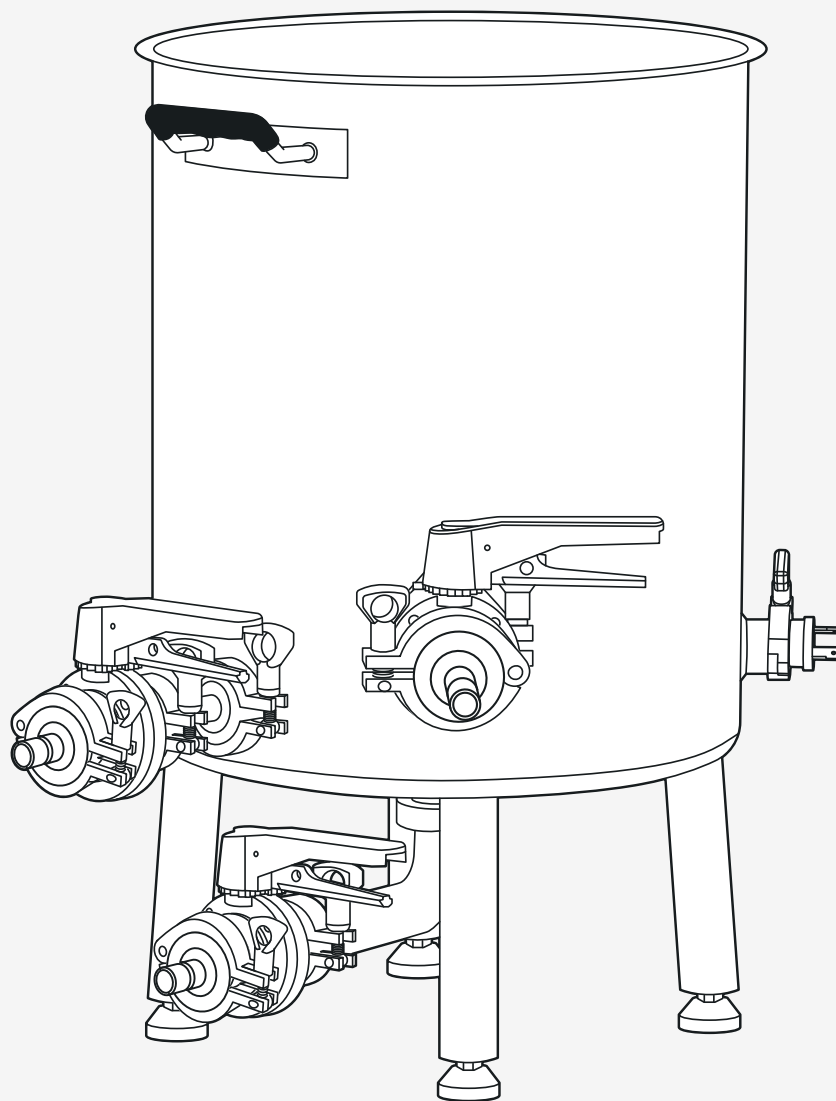

# Assembly – Kettle

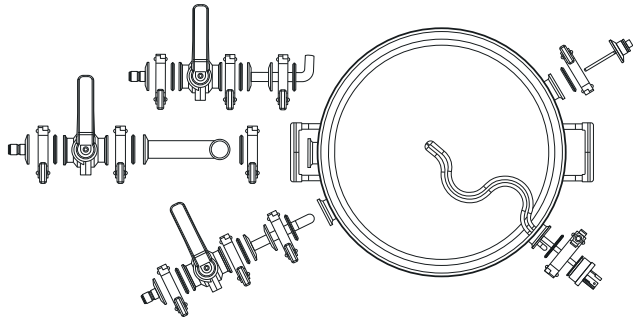

ITEM	DESCRIPTION	QTY
A	1.5" TC X QC	3
B	1.5" TC Clamp	11
C	1.5" TC Gasket	11
D	1.5" TC Butterfly Valve	3
E	Spike+ Pickup Tube - Side	1
F	1.5" TC Element	1
G	1.5" TC Temp Sensor	1
H	Bottom Drain Piping	1
I	Boil Kettle Racking Arm	1

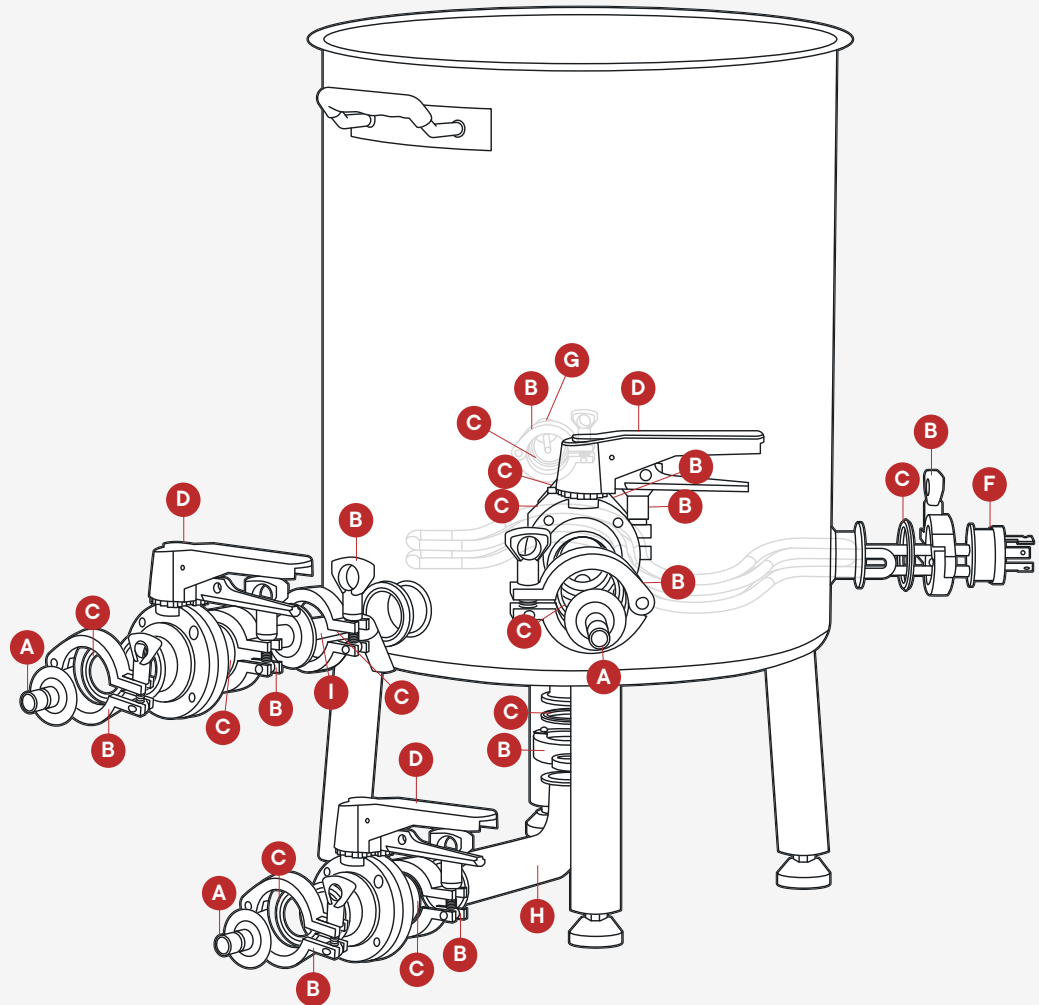

## Assembly – Basket

Use 2 feet of your silicone tubing to create a sparge arm from the top recirc port. The tubing will float on top of the grain bed allowing for an even recirculation.

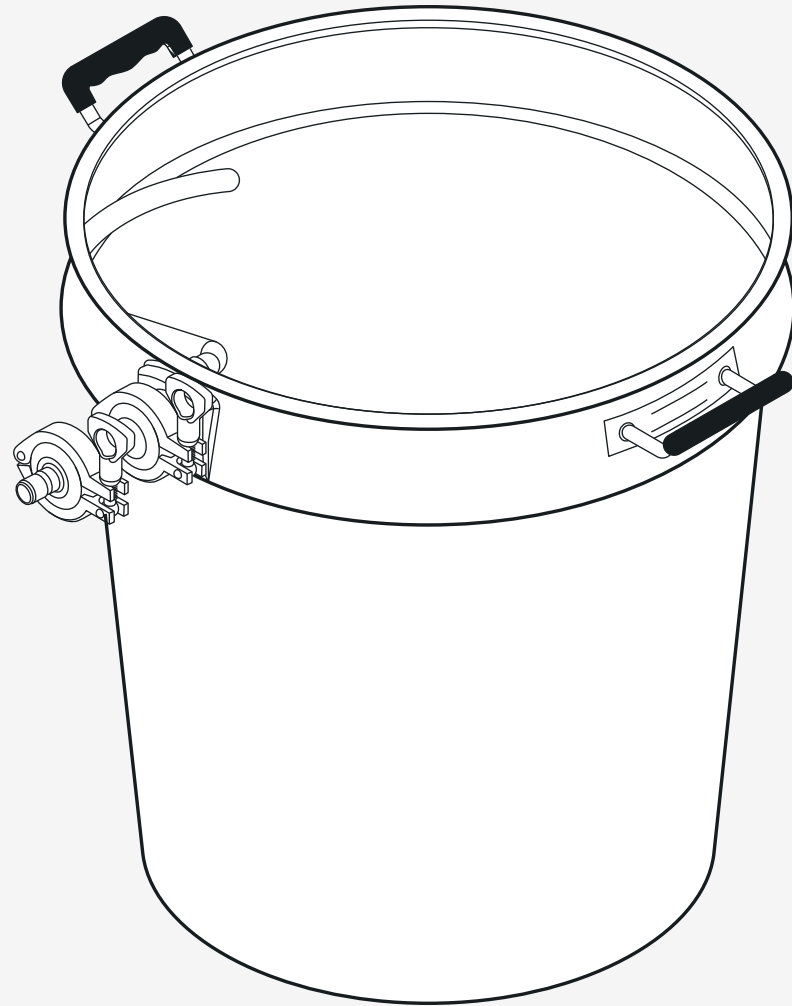

# Assembly – Basket

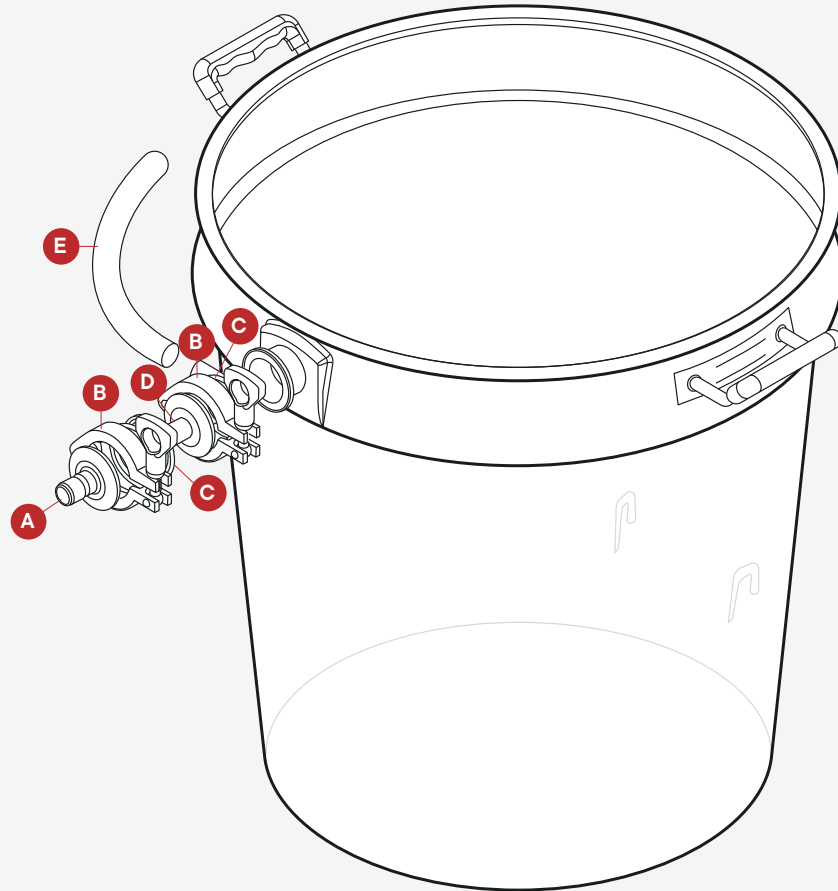
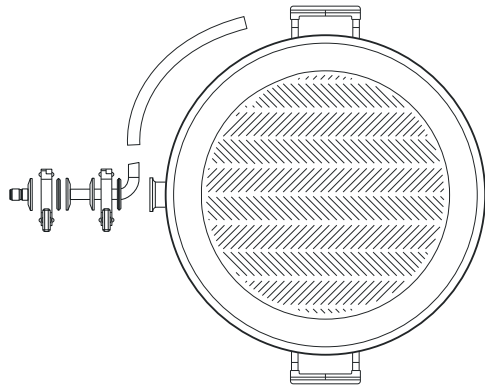

ITEM	DESCRIPTION	QTY
A	1.5" TC X QC	1
B	TC Clamp	2
C	TC Gasket	2
D	Spike+ Pickup Tube - Side	1
E	Mash Recirculation Hose	1



# Assembly – Kettle & Basket

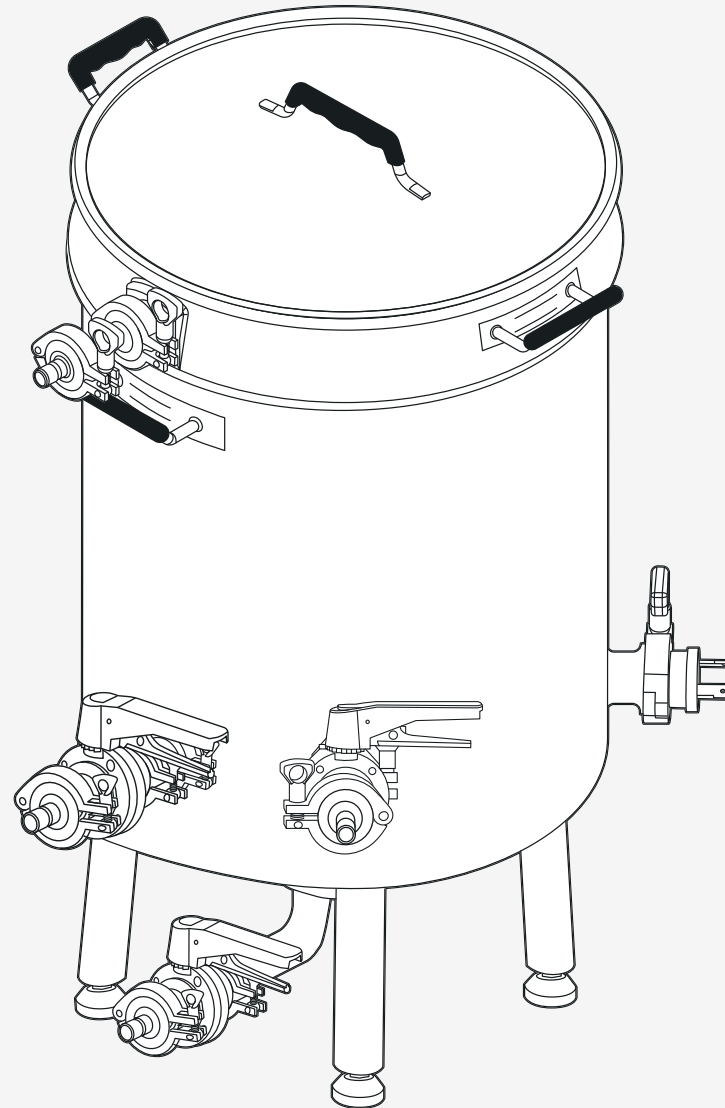

# Assembly – Kettle & Basket

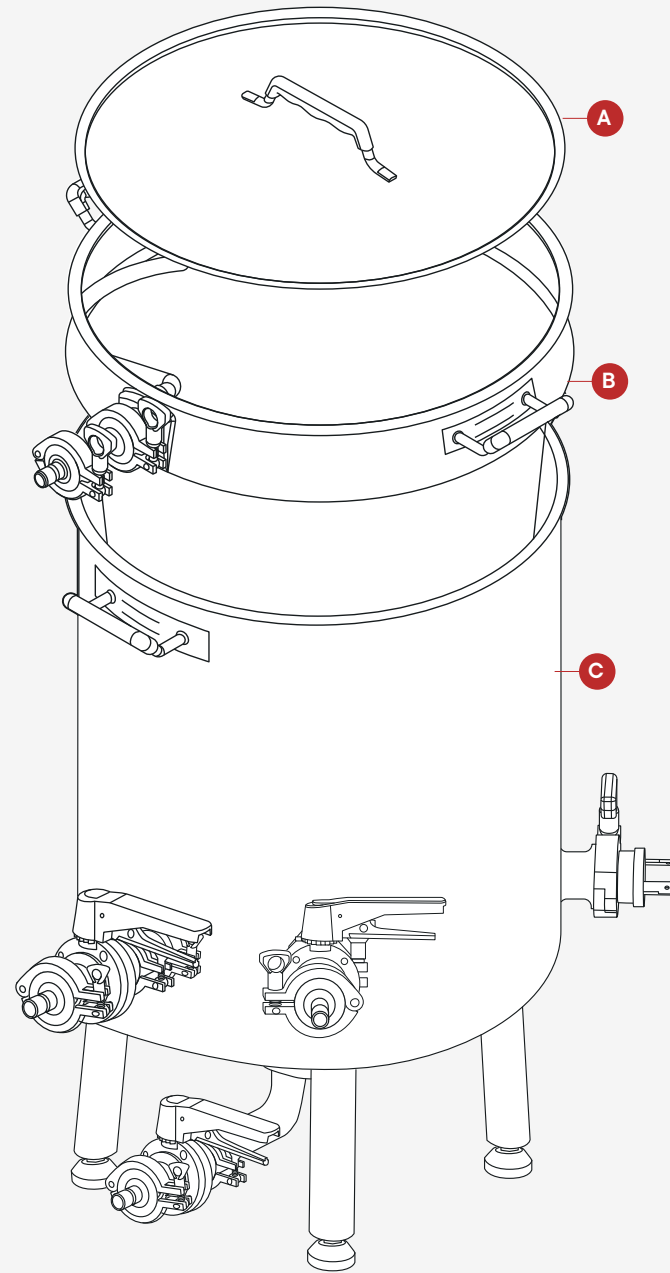
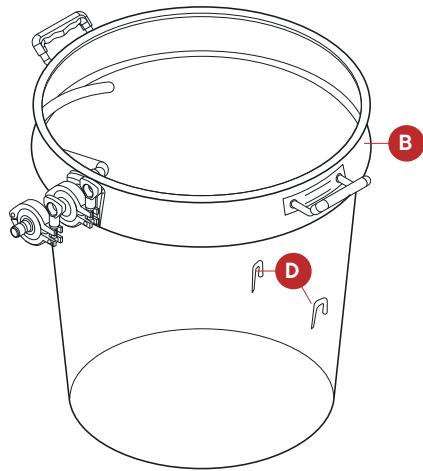

ITEM	DESCRIPTION	QTY
A	Lid	1
B	Basket	1
C	Kettle	1
D	Basket hangers	2

# Assembly – Table

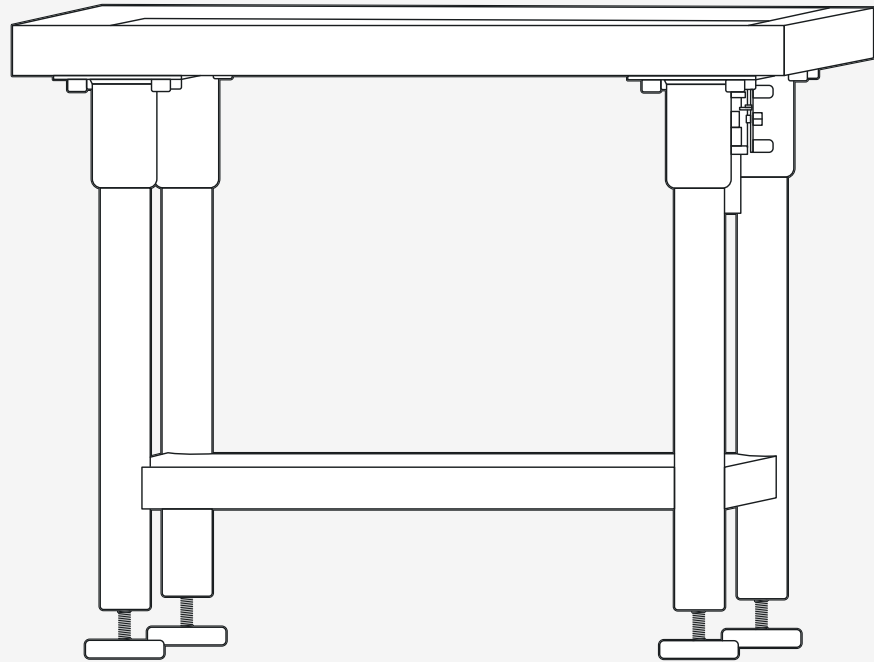

# Assembly – Table

ITEM	DESCRIPTION	QTY
A	Tabletop	1
B	Shelf	1
C	Legs	4
D	Short Bolt	16
E	Washer	20
F	Split Lock Washer	20
G	Long Bolt	4
H	Allen Wrench	1
I	Drain Valve	1
J	Feet	4
K	Wort Chiller Mount (Only included with Wort Chiller purchase)	1
L	Wort Chiller Bolt (Only included with chiller)	6
M	Wort Chiller Nut (Only included with chiller)	4
N	Pump Bolts	4

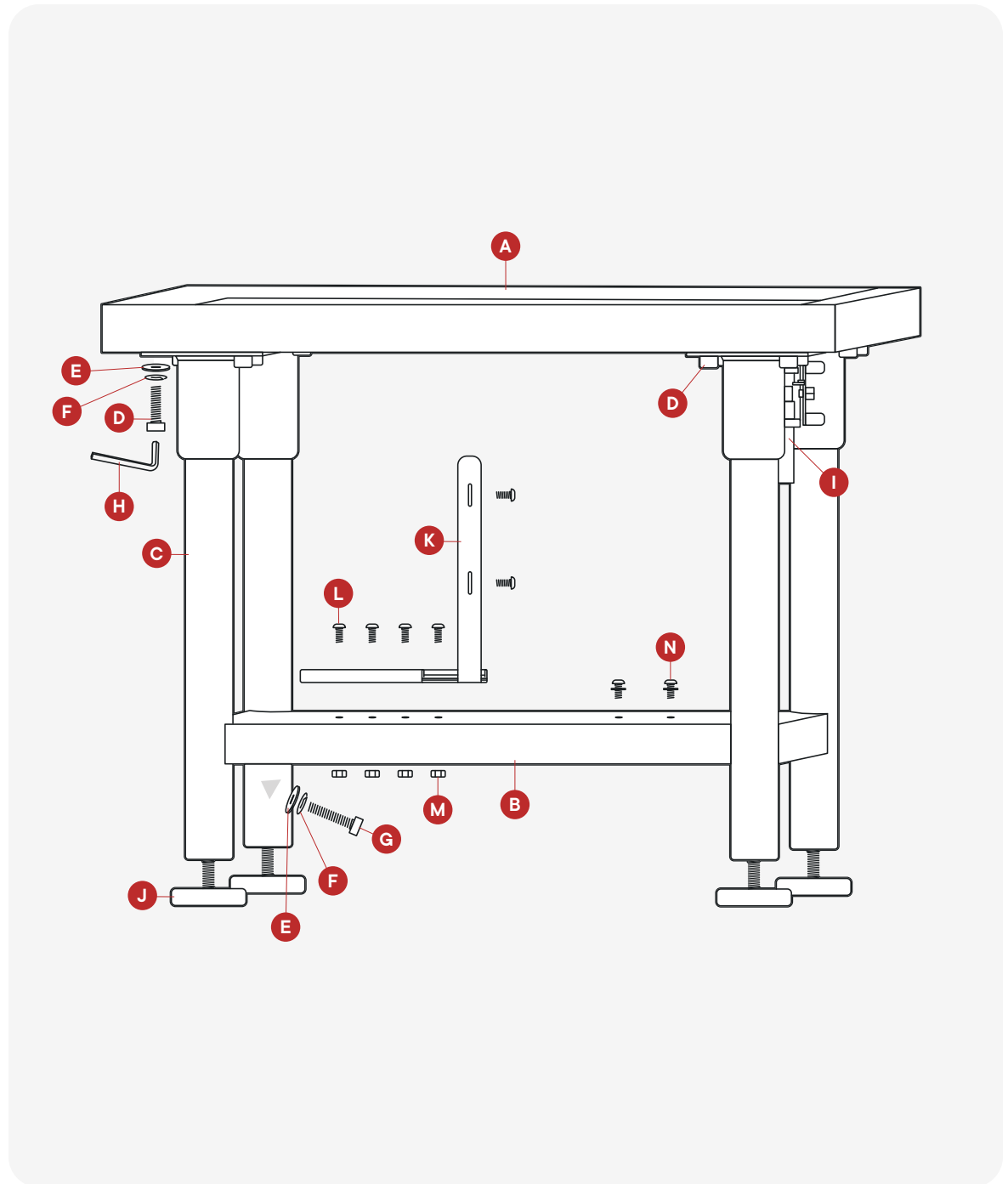

# Assembly – Table

## Assembling the table

1. Place the Tabletop upside down.
2. Line up each leg with the 4 corners of the table.
3. Use the Allen Wrench to screw 4 short bolts to attach legs. Be sure to use a Washer and Split Lock Washer with each bolt.

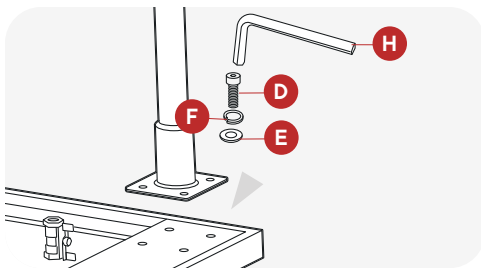

4. Insert the Shelf through the legs until they align with the holes in the legs (if the Bolts are pre-installed on the legs, remove them prior to inserting the Shelf)
5. At each leg, use one Long Bolt, Washer, and Split Lock Washer to secure the Shelf.

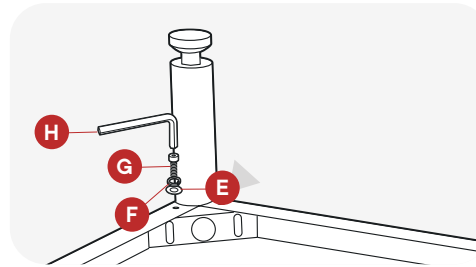

6. Install the Leveling Feet by first tightening the nut directly on top of the foot to secure it.
7. Thread the foot into the leg then tight the other nut on to the leg. Repeat this for the other legs
8. If needed, adjust how far the foot is threaded into the leg to make the table level

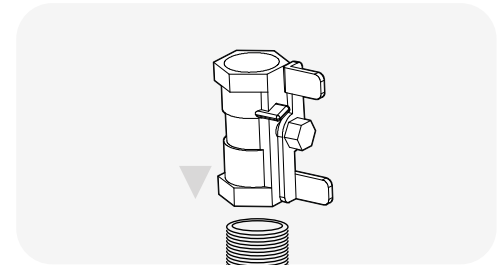
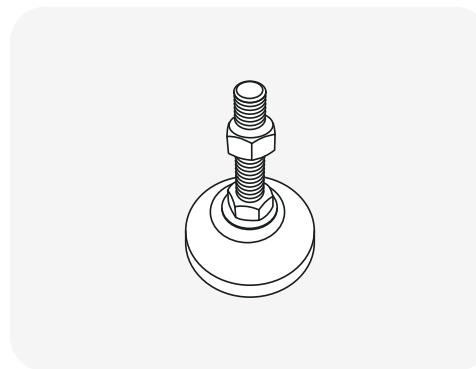

9. Screw the Drain Valve into the Drain in the table.
10. Turn your table over.
11. If mounting a pump, place the pump over the set of 4 threads in the table. Use 4 Pump Bolts, Washers, and Split Lock Washers to attach each mount to the table
12. If attaching the wort chiller, use 4 nuts and bolts to attach the Wort Chiller Mount to the Shelf. Then use two bolts to secure the bracket to the bolts in the Wort Chiller

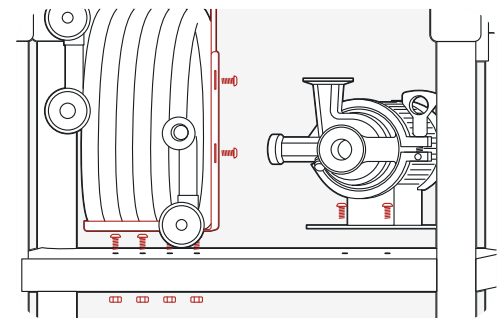

## Assembly – Wort Chiller

Our counterflow chiller is made from stainless steel and lined with super-conductive copper, which provides fast chilling speeds. The chiller comes with QC fittings, so you can quickly connect to the rest of your system. It also includes a tee fitting and additional temp probe so you can monitor the inline chilling temps going into your fermenter.

To get started, attach the temp probe cable from your mash tun to the tee on the chiller. You'll be able to see the chiller exit temp on the control panel and adjust the flow rate to achieve your perfect yeast pitch temp.

If you have high groundwater temps, we recommend submerging your chiller in an ice water bath for the last leg of chilling.

The hot water exiting the counterflow chiller can be saved and reused for cleaning!

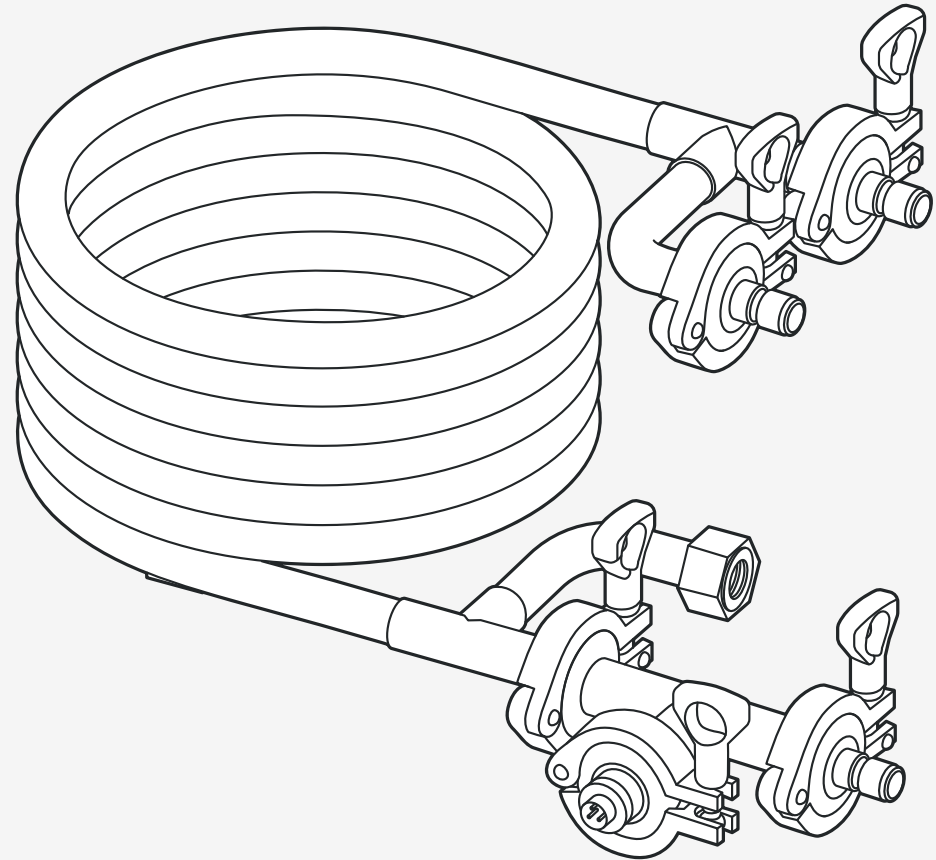

# Assembly – Wort Chiller

ITEM	DESCRIPTION	QTY
A	Wort Chiller	1
B	1.5" Gasket	5
C	1.5" Clamp	5
D	1.5" TC x QC	3
E	1" TC Tee	1
F	Temp Probe	1
G	Hose Gasket	1

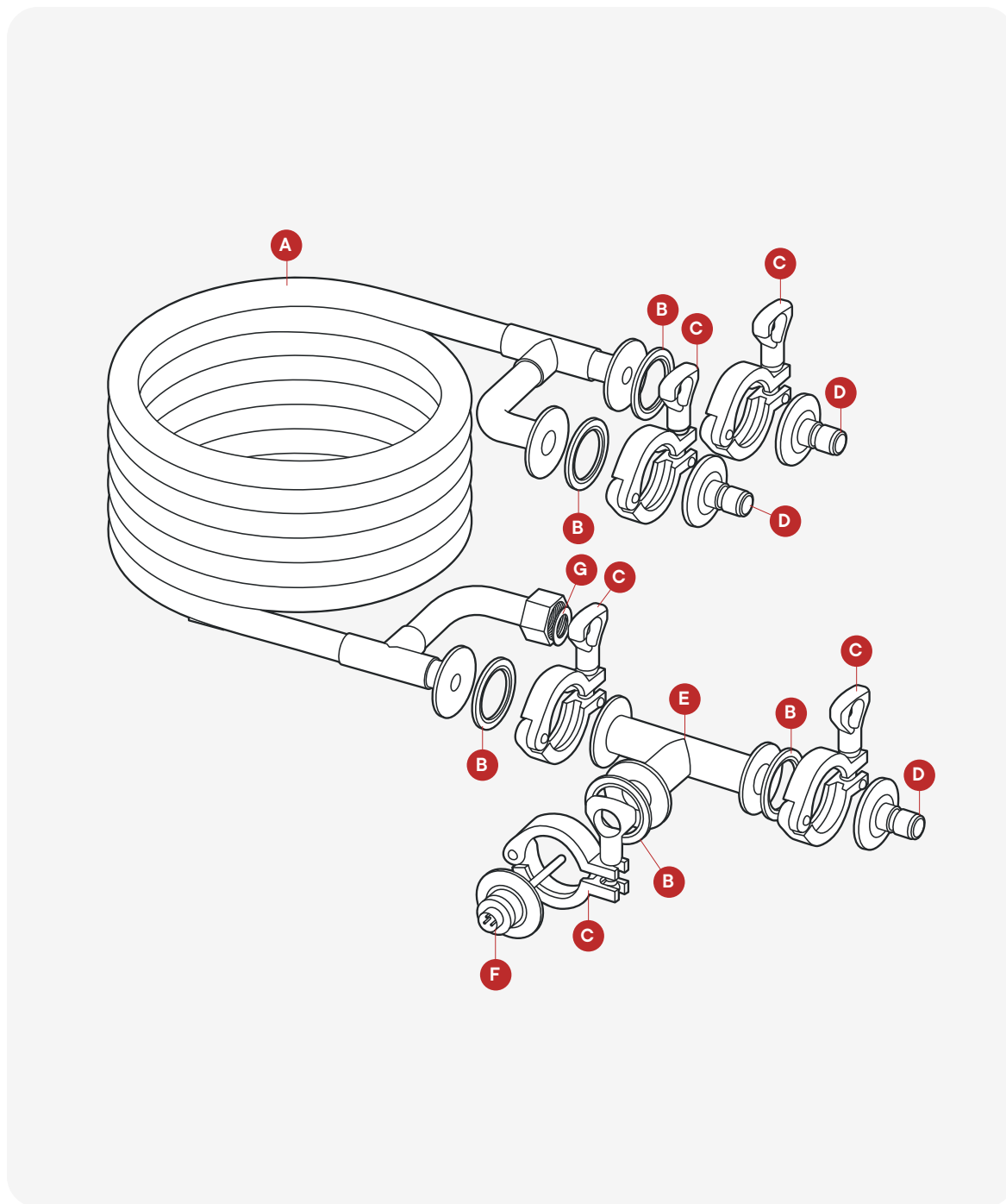

# Assembly – Pump

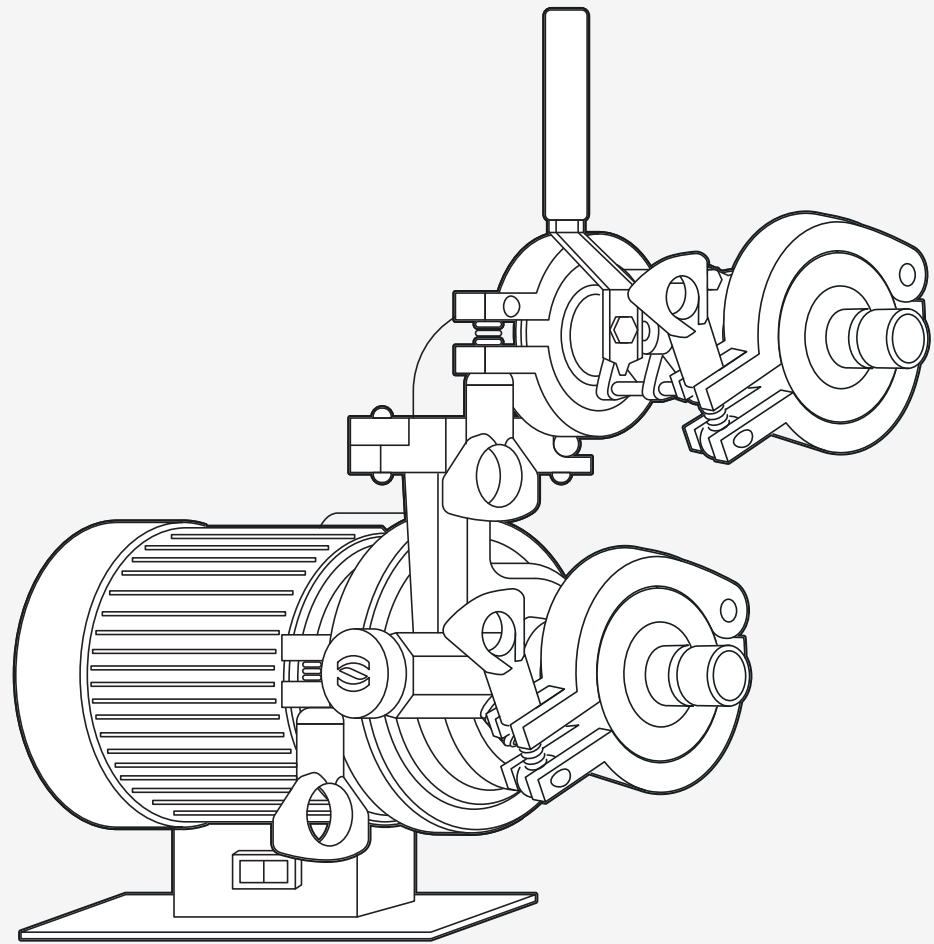



# Assembly – Pump

ITEM	DESCRIPTION	QTY
A	Spike Flow Pump	1
B	90 degree elbow	1
C	1.5" TC Clamp	4
D	1.5" TC Gasket	4
E	1.5" TC X QC	2
F	TC 3pc Valve	1

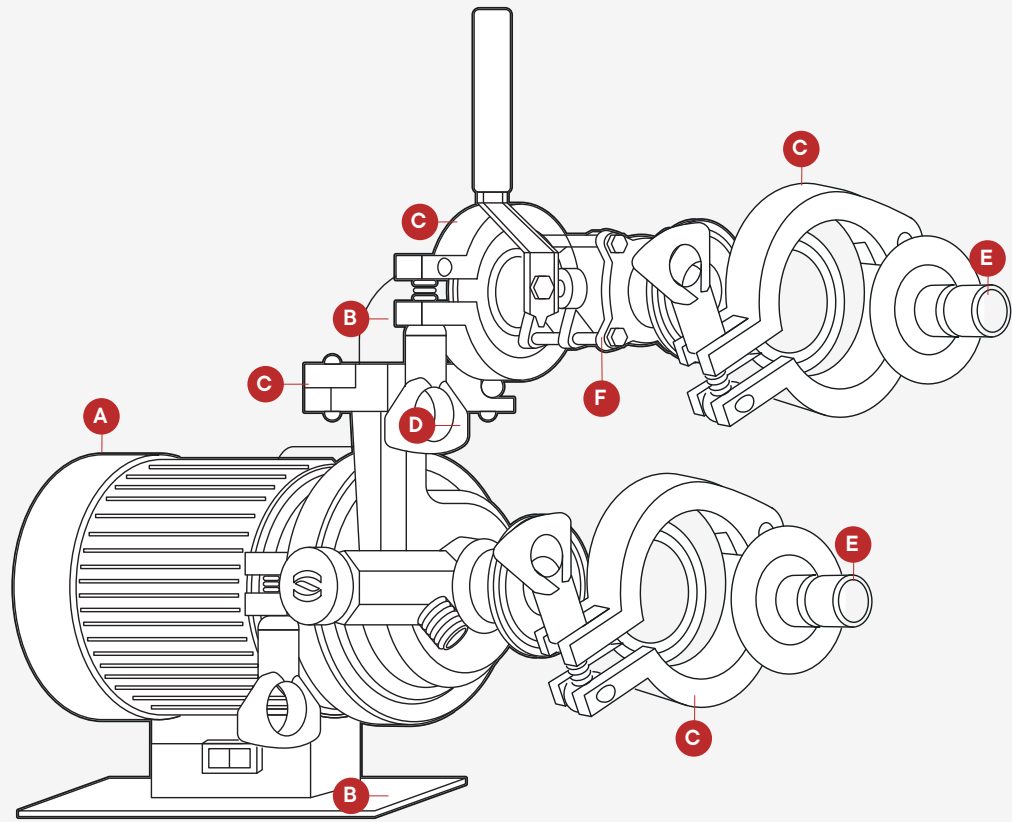

# Assembly – Hoses

We use oversized barbs, which creates a secure attachment without the need for sharp hose clamps. The quick connect fittings also use a full port design which doesn't restrict the flow through the fitting resulting in a quicker brew day.

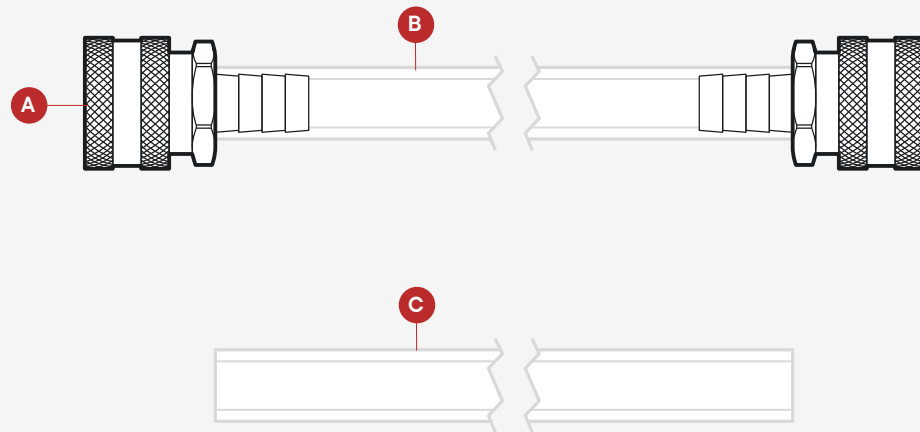

ITEM	DESCRIPTION	QTY
A	FQC x Barb	4
B	Hose - 4'	2
C	Mash Tun Recirculation Hose - 2'	1

# Assembly – Panel

**NOTE:** This panel is designed to use the following receptacles -

120V: NEMA 5-15 3-prong on 15A breaker

240V: NEMA 14-30 4-prong on 30A breaker

Do NOT plug anything into these ports that are outside of the wattage limits

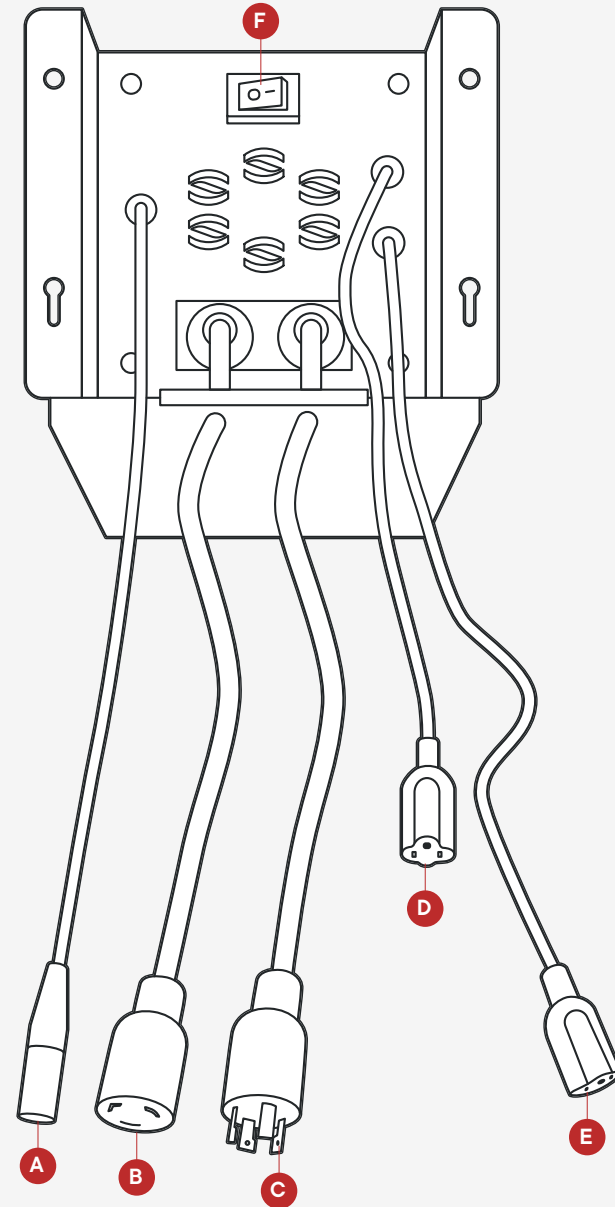

ITEM	DESCRIPTION
A	Temperature Probe Plug
B	Heating Element Plug
C	Power Plug
D	Pump Plug
E	Auxiliary Plug
F	Power Switch

# Brew Day Guide

Now that your Solo is fully assembled, it's time to get brewing.  
Follow the steps in this user guide for a simple and easy Brew Day experience.

**Using the Control Panel**

**Heat Strike Water**

**Mashing**

**Drain (Lauter)**

**Boil**

**Whirl Pool**

**Chill (Knockout)**

**Cleaning**

# Using Your Solo Control Panel

- A. Element Switch** - turns on your heating element. This circuit can handle heater load up to 25A / 6000W.
- B. Pump Switch** - turns on your brew pump. This circuit can handle load up to 1.5A / 180W.
- C. Aux Switch** - turns on whatever you connect to your auxiliary outlet. If you have our Steam Condensing Lid, plug in the submersible pump here. This circuit can handle load up to 1.5A / 180W.
- D. Temperature / Power Dial** - rotate the dial to adjust the temperature or power percentage. Be sure to push the dial to confirm the new set point. The number will be yellow while you adjust it. When it turns white, it is set.
- E. Heating Mode Dial** - change between Boil and Mash modes. For Mash Mode (typically used for mashing), set your temperature and the controller will heat up your batch to that temperature and maintain it. For boiling, use Boil Mode. When you're ready to start the Boil, press the button and set the percentage to 100% to get to a boil as fast as possible. After reaching a boil, you can lower the percentage to get a less aggressive boil (80–90%). If you are using our Steam Condensing Lid, use 40–50% power after the boil starts.

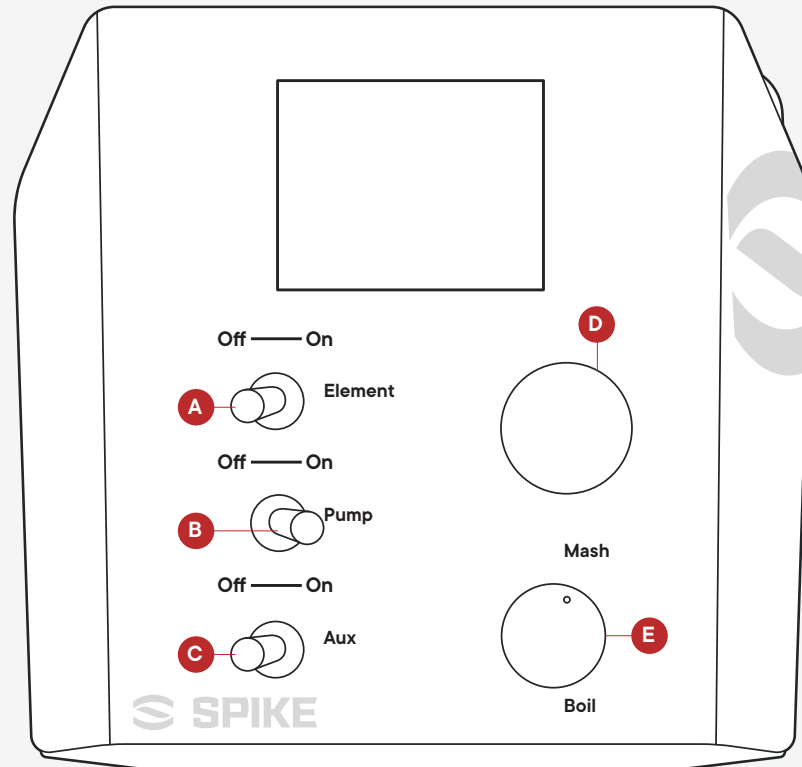

# Setup – Solo Panel

## Getting Started

Your panel is ready to use out of the box! No need to autotune the panel.

1. Remove the panel from the box and place it in your desired location.
2. Attach your element cord to the element and control panel. These items are sold separately.
3. Connect your pump to the panel in the labeled outlet.
4. Connect your temperature sensor to your panel and to your temperature probe (sold separately).
5. Lastly, plug the panel power cable into the wall and panel.
6. To power the panel, flip the switch underneath the front. The display will turn on and after a few seconds the home screen will appear.

### PRO TIP:

- Make sure your temperature probe quick connections are clicked in all the way.
- The panel has an internal cooling fan, which creates a soft hum when turned on.
- Do not turn on your element unless it is submerged in liquid.

## Controlling Your Mash

Ready to Mash in? The panel has 2 temperature control options, Mash and Boil. “Mash Mode” allows you to set a specific temperature, and the heating element will hold the liquid at that temperature.

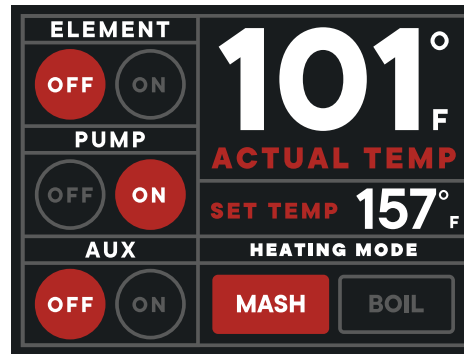

1. Rotate the small knob in the lower right hand corner to MASH. The display screen on your panel will highlight “MASH” as shown in the Graphic.
2. Rotate the larger knob to adjust your “Set Temp”. The value will blink yellow.
3. Once the temperature value you want is showing, push the knob down one time. The value will no longer blink yellow. This means the value is entered.
4. Turn your element to “ON” using the dedicated toggle switch. Your element will now heat to the set temperature.

### PRO TIP:

- The controller can be set from 0–215F/0–105C
- Your element will not turn on in “Mash Mode” until your temp probe is plugged into the panel and reading the temperature properly.

## Controlling Your Boil

Ready to boil? Be sure to change your setting to “Boil Mode” which will allow us to control heating output by percentage instead of actual temperature. The panel will fire the electric heater at the % duty cycle displayed, which allows your kettle to reach a rolling boil quicker than if it were set to temperature control mode.

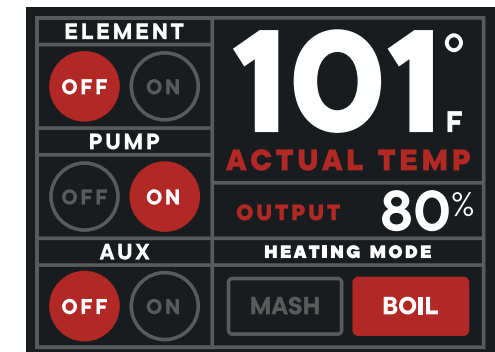

1. Rotate the small knob in the lower right hand corner to BOIL. The display screen on your panel will highlight “BOIL” as shown in the graphic.

# Setup – Solo Panel

1. To adjust the desired % output, rotate the large knob. The value will blink yellow.
2. When the % output is showing your desired % on your panel, push the knob down one time. The value will no longer blink yellow. This means the value is entered.
3. Turn your element to “ON” using the dedicated toggle switch. Your element will now heat to the set output.

**PRO TIP:** The controller can be set between 0–100% output.

## Changing the Temperature Display Units

The Solo panel can display temperature in Fahrenheit and Celsius..

DEVICE SETTINGS	
UNIT	F-degree
TEMP OFFSET	0°F
ABOUT	
BACK TO HOME SCREEN	

1. Push down the large knob for 3 seconds. The “DEVICE SETTINGS” screen will appear.
2. Rotate the large knob to highlight the “UNIT” line.

3. Press the knob to move to the units you are looking for. You will see the screen display switch from “F-degree” to “C-degree” depending on what you choose.
4. Use the knob to highlight “BACK TO HOME SCREEN”. Press the knob down to return to the main screen.

## Adding a Temperature Offset

The Solo Panel can apply a temperature offset to the sensor value displayed on the main screen. This is used to accommodate differences sometimes found between the temperature sensor and the middle of the grain bed.

DEVICE SETTINGS	
UNIT	F-degree
TEMP OFFSET	5°F
ABOUT	
BACK TO HOME SCREEN	

1. Push down and hold the large knob for 3 seconds. The “DEVICE SETTINGS” screen will appear.
2. Rotate the large knob to highlight the “TEMP OFFSET” line. Press the knob down once.
3. Rotate the knob to the desired offset value. The value will blink yellow.
4. Once your desired value is showing on your panel

screen, press the knob down one time. The value will no longer blink yellow. Your value is set.

5. Use the knob to highlight “BACK TO HOME SCREEN”. Press the knob down. You will return to the main screen.

**PRO TIP:** The panel can adjust your temp offset +/- 25 degrees

## Using the Toggle Switches

There are three toggle switches in your panel – Heating Element, Pump, Aux. These switches act as simple controls to turn your plugged in devices on and off. The display screen will correspond and highlight to show which mode of ON/OFF you are in.

**NOTE:** *The Heating Element will not switch on and operate in MASH mode unless there is a proper temperature sensor plugged in reading the correct value. This is a safety precaution to make sure there is always an acceptable value within range for the temperature control algorithm to function properly.*

## Brew Day – Heat Strike Water

During this step you'll heat all the water needed (called strike water) to add your crushed grain which will make your mash. Since this is a single vessel, no sparge system you'll add your entire volume of strike water to your kettle during this step.

Figure 1

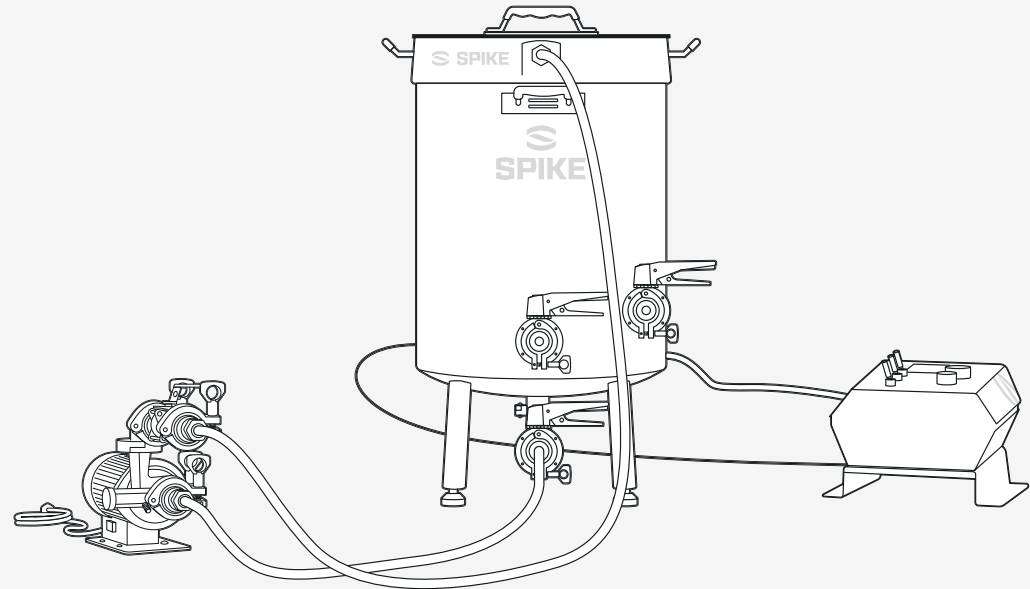

1. Fill your kettle with the entire volume of strike water as prescribed by your recipe. Use the etched volume markers inside the kettle.
2. After filling the kettle with the correct amount of strike water place the basket into the top of the kettle.
3. Connect one hose from the bottom drain valve to the inlet on the pump.
4. Connect the other hose from the pump outlet to the inlet port on the basket. (see **Figure 1**)

5. Open the kettle drain valve and the pump valve.
6. Set your controller to the desired mash temperature and turn the element on.

7. Turn the pump on and let the kettle heat up until it reaches the desired temp. Put the lid on to help retain heat and speed up heat up times. The constant recirculation from the pump will make sure the temps are consistent throughout the entire kettle and basket.

**PRO TIP:** Set your controller roughly 3–5 degrees higher than your desired mash temps. Since the grain is colder than mash temps it will lower the temperature inside the kettle/basket once the grain is poured in.

**PRO TIP:** When priming your pump make sure the pump outlet valve and kettle valves are open so liquid can flow through the pump which will push any air out of pump head. If the pump head has air inside it will not work properly.



## Brew Day – Mashing

During this step the crushed grain will be added to the hot water creating a mash. This hot water converts the starches in the grain into sugars. Eventually these sugars will be 'eaten' by the yeast and alcohol will be created.

1. Ensure your hoses are properly set up (see **Figure 2**).
2. Turn the pump off, element off and remove the lid. The lid can conveniently hang on the back kettle handle.
3. Slowly start pouring your crushed grain into the basket. Either have a brew partner stir while you pour the grain in or pour a little at a time and stir in between pours. This stirring will make sure all the grain gets into contact with the strike water and no dough balls are created.

**PRO TIP:** We recommend letting the grain rest for 5–10 minutes to fully hydrate before turning the pump and element on. This will reduce grain pass through and reduce the change of a stuck mash.

4. Set your controller to your desired mash temps and turn the element on.

Figure 2

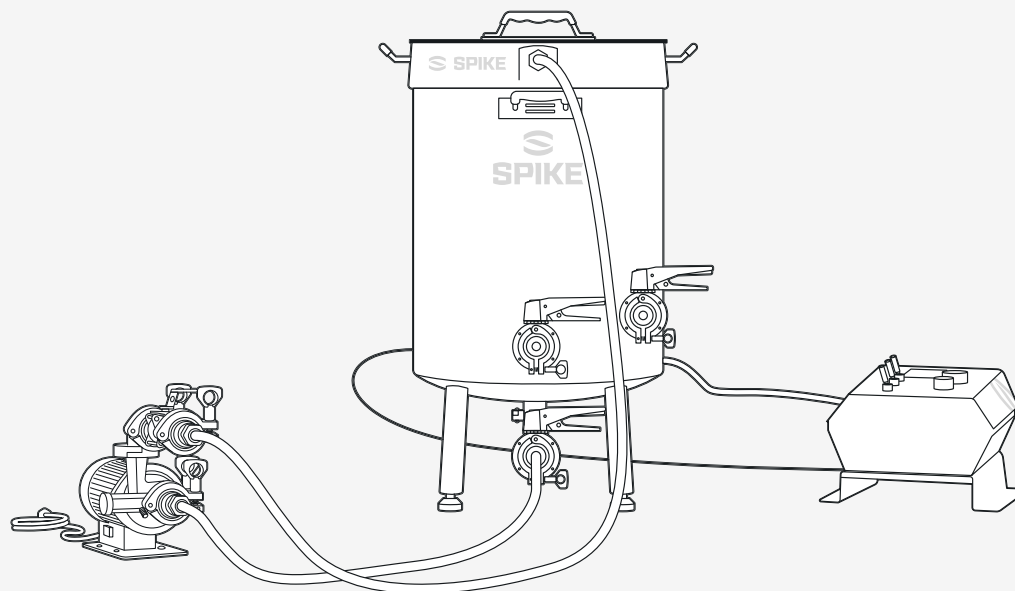

5. Turn your pump on and slowly open the ball valve on your pump. Restrict the flow to about ¼ of full flow.

**PRO TIP:** Always use the ball valve on the pump to restrict the flow. This valve will control the flow most accurately. Never restrict the flow to the pump as it will starve the pump of liquid and can cause premature wear.

**PRO TIP:** We recommend a constant recirculation during the entire mash as it helps maintain the most consistent temperatures, as well as helps raise brewing efficiency.

**PRO TIP:** The volume in the basket should stay at roughly the same height throughout the mash. If the volume starts to increase, there is most likely a stuck mash meaning the filter at the bottom of the basket is clogged with grain. If the liquid level increases, simply turn off the pump, stir the mash for a minute and then turn the pump back on. This should unclog the filter!

**PRO TIP:** Turn the pump off the last 5 mins to let all liquid start draining out of the basket.

## Brew Day – Drain (Lauter)

Now it's time to separate the grain from the sugar water that was created (wort). The spent grain can be used for baking, dog treats, fertilizer, etc while the wort will be boiled.

1. Turn the element and pump off.
2. Lift the basket out of the kettle and carefully rest the basket on top of your kettle with both hooks secured over the top lip of the kettle. (see **Figure 3**)

**CAUTION:** We recommend having two people lift the basket and placing on the kettle for safety reasons.

Figure 3

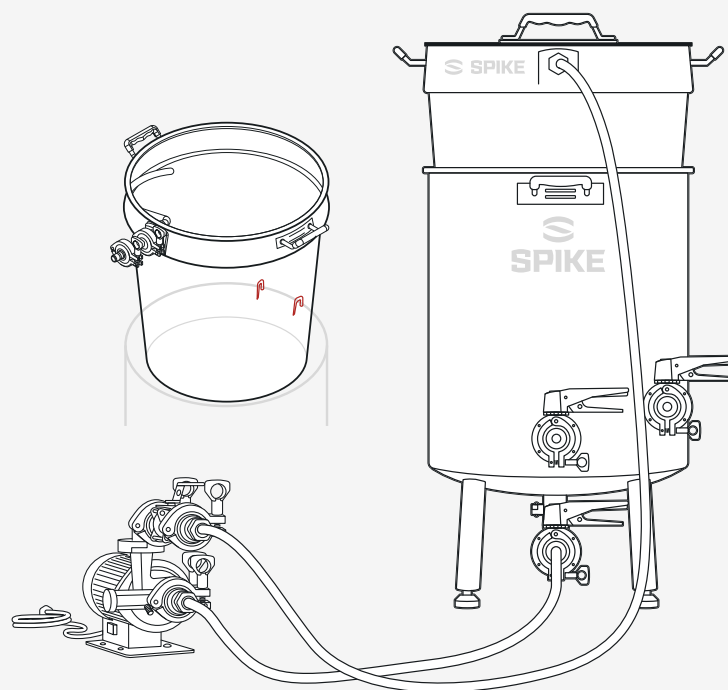

**PRO TIP:** With the basket raised out of the wort and hanging from the basket hooks the pump can be turned back on at about  $\frac{1}{4}$  flow. This is called a 'vorlauf' and will help with wort clarity. The grain acts as a filter and recirculating the wort in the kettle back through the grain will allow the clear liquid to flow through while the solids are trapped in the grain bed. We recommend doing a vorlauf for 10 minutes.

3. Let the basket hang on the kettle until it stops dripping wort. This should take 5–10 minutes. However while the basket is draining you can proceed to Step 4 and turn on the element.

## Brew Day – Boiling

Follow these steps to keep things rolling during the boiling step. We will boil the wort we just created, which helps evaporate off flavors and concentrate the wort.

1. Close all the valves.
2. Disconnect the hose from the basket inlet valve and attach it to the whirlpool (upper) port on the kettle. Disconnect the hose from the bottom drain valve and attach it to the racking (lower) port on the kettle. (see **Figure 4**)
3. Set your controller to Boil Mode, set the output to 100% and turn on the element. (see **page 21 section: controlling you Boil**)

**PRO TIP:** The controller will be changed from 'mash' mode to 'boil' mode during this step. In mash mode the controller will precisely control the temperature which is beneficial during the mash step. However during the boil step we're more interested in getting a good rolling boil. The controller in boil mode will let you precisely adjust the output to get a good rolling boil.

4. After the basket is done dripping remove it from the kettle.
5. Allow the element to bring the wort to a boil. Once at boil the controller can be dialed back so a steady rolling boil is achieved.

Figure 4

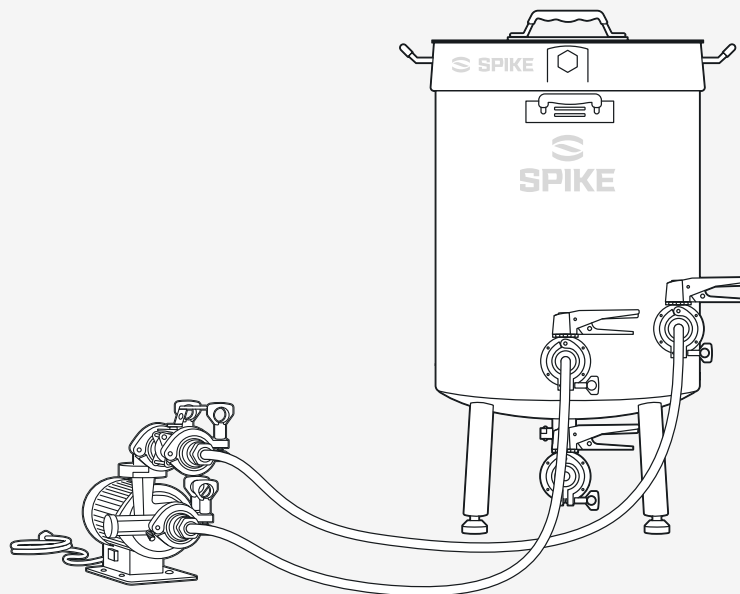

**PRO TIP:** When wort is about to reach boiling an issue called 'hot break' can occur. The wort can begin to rise and boil over the top of the kettle. This is very similar to boiling pasta. If this starts to happen simply turn the element off and stir the wort. You may need to repeat this a few times but it should subside once your 5 minutes into the boil.

6. Add your hops as needed and boil for the recommended time the recipe calls for.

## Brew Day – Whirlpool

Let's take that wort out for a spin. During this step the wort will be run into the pump and back into the kettle at an angle. This will create a "whirlpool" inside the kettle, causing the sediment like grain, hops and proteins to collect at the bottom center of the kettle. This step allows for a clear wort transfer into your fermenter.

1. Turn off the element.
2. Open the racking valve on the kettle, the valve on the pump and the whirlpool valve on the kettle
3. Turn the pump on.
4. We recommend whirlpooling for 10-15 minutes.
5. Turn the pump off and close all the valves.
6. Allow the kettle to sit for 5 minutes after turning the pump off, so the whirlpool can finish dropping all sediment.

Figure 5

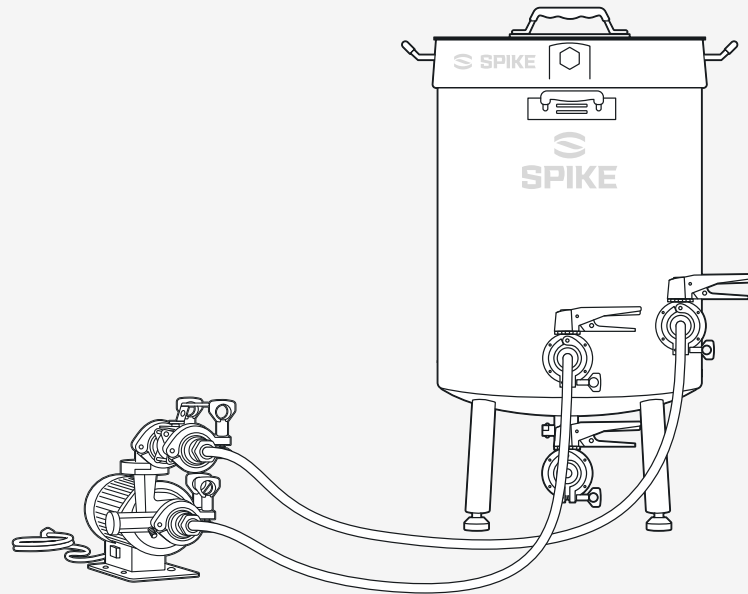

## Brew Day – Chill (Knockout)

During this step the wort is cooled down from the near boiling temperatures down to what is called ‘yeast pitching’ temperatures and transferred to a fermenter. This simply means we are cooling the wort down to temperatures where yeast can be added without causing them harm. Typically 70F is a good knockout temp.

1. If you're using our optional counter flow chiller, move the hose from the whirlpool port to the wort inlet port on the chiller.
2. Make sure your chiller and fermenter are sanitized.
3. The cable from the temperature sensor on the kettle can be attached to the temperature sensor on the chiller. This will give the temperature reading of the wort exiting the chiller.
4. Open the racking valve on the kettle and the valve on the pump so it is just cracked open. When chilling you'll want the flow rate to be very slow.

Figure 6

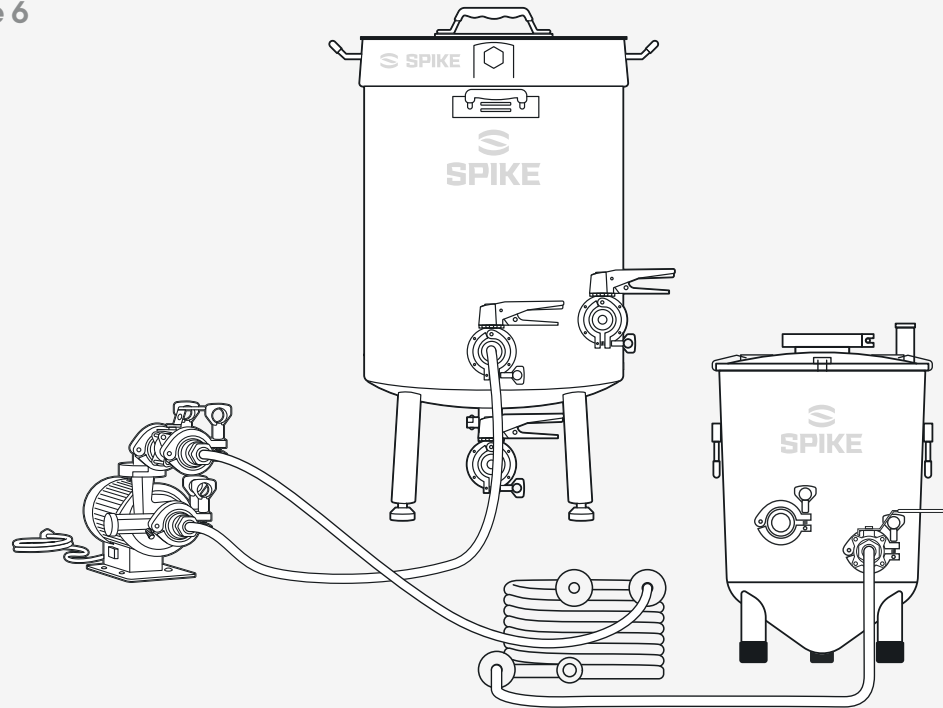

**PRO TIP:** If you use our optional counterflow wort chiller the outlet water will be roughly 150F which can be collected and used for cleaning your equipment while conserving water.

5. Turn the pump on.
6. Once the kettle has been completely drained into your fermenter close all the valves.

# Brew Day – Cleaning

Follow these steps to speed through the cleanup process and keep your equipment running smoothly for your next Brew Day.

## Kettle

1. Dump remaining trub and hop material out of your kettle.
2. Rinse the kettle out to remove large particulates.
3. Fill your kettle about 1/4 full with hot water and add your brewery wash.
4. Connect the tubing (see **Figure 7**) and open the valves.
5. Turn the pump on and allow to run for about 5 minutes while you scrub the inside of the kettle clean. This will clean the tubing, pump and hardware internals.
6. Connect the hose currently connected to your racking port to the bottom drain port. (see **Figure 8**) Turn on the pump for 5 minutes to clean the bottom drain then turn off the pump. Be sure to restrict the outlet of the pump enough to prevent a whirlpool from forming. A whirlpool with a small amount of liquid could create a vortex in the bottom drain that allows air to get into the pump and cause it to malfunction

**PRO TIP:** Open and closing the valves a few times will help clean them more thoroughly.

Figure 7

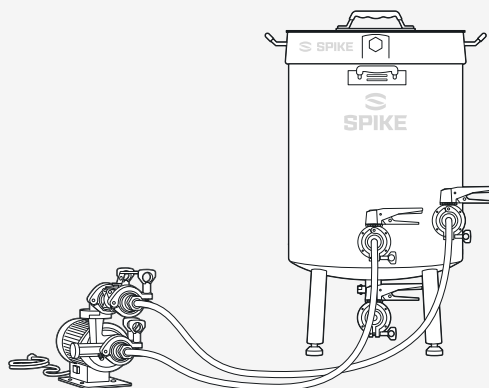

**PRO TIP:** Run some of the brewery wash through the baskets inlet to help clean the hardware internals.

7. Once the kettle and hardware are clean, attach a hose from the pump outlet to the wort chiller outlet, and drain the kettle. This will backflush the chiller and clean it for your next brew day.
8. Repeat the above steps with clean water to rinse the cleaner.

**PRO TIP:** You can add Star San with your rinse water to rinse and sanitize at the same time.

Figure 8

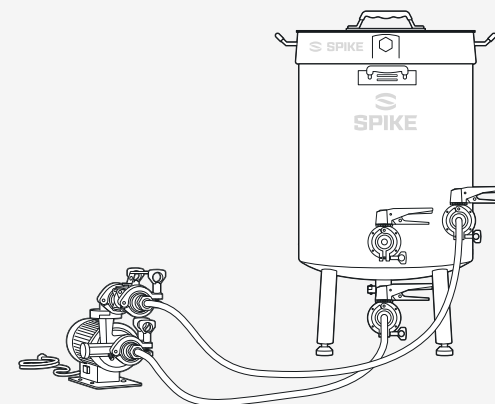

## Basket

1. Scoop or dump grain out of the basket.
2. Rinse the basket off.
3. Scrub the basket clean with brewery wash or dish soap.
4. Rinse the cleaner off the basket.

**PRO TIP:** Use BKF to shine stainless back up. Avoid logo and volume etchings as they can dull over time.