

The logo for Urikar features a stylized red smile above the brand name. The brand name "Urikar" is written in a bold, white, sans-serif font. The letter "U" is unique, with a red smile-like shape above it.

Urikar

MASSAGE GUN

Pro 1

User Manual

English	01
Deutsch	08
Français	15
Español	22
Italiano	29
日本語	36

CONTENTS

1. What's in The Box	01
2. Introduction to The Pro 1	01
3. How to Use	02
• Using The Pro 1	
• Choose Angle of Handle	
• Choose Mode	
• Choose Massage Head	
• Charging	
4. Parameter Information	07

What's in The Box

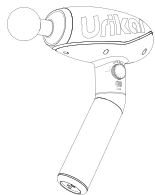

Urikar Massage Gun Pro 1 x1

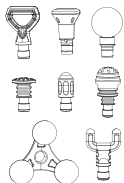

Massage Heads x8

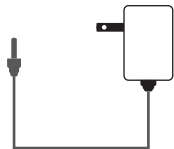

Power Charge x1



User Manual x1



Handbag x1

Introduction to The Pro 1

- ① Touch Sensing Area
- ② Power Switch
- ③ Mode Key | Mode Indicator
- ④ Speed Knob
- ⑤ Handle-Rotation Button
- ⑥ Speed Level Indicator
- ⑦ Power Indicator & Battery Indicator
- ⑧ DC Input Port

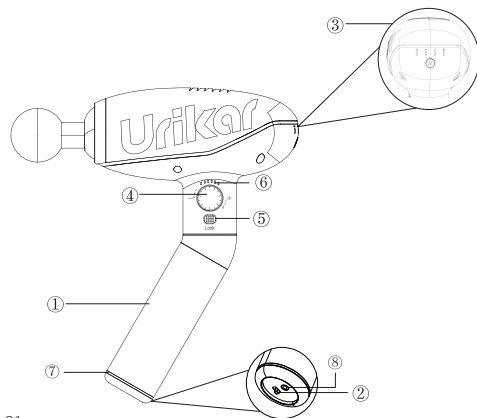

How to Use

● Using The Pro 1

1. Turn on the power switch ② and hold the handle (Touch sensing area ①), and the massage gun will turn on.

Note: The power indicator ⑦ will light blue and rotate once, while the handle vibrates.

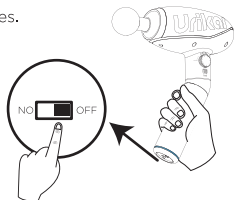

3. Put down the handle and the the massage gun stops working automatically.

Note: If it is not used for a long time, please turn off the power switch.

● Choose Angle of Handle

Hold handle-rotation button ⑤ to change the angle of the handle (180°-rotatable), which is convenient for massaging the back muscles.

Note: You can hear a click when the rotation is completed.

2. Adjust the speed knob ④, and the massage gun starts to work (Adjust the mode and speed according to your physique and preferences).

Speed knob: 0-6 gear, rotate clockwise to increase the gear, counter clockwise to decrease, and adjust to the lowest gear for standby.

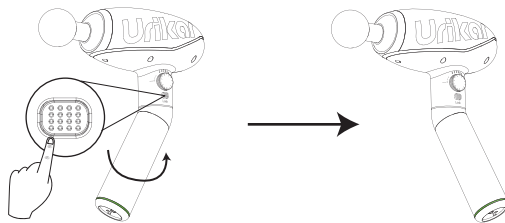
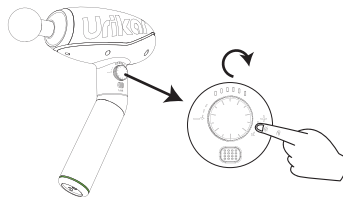

● Choose Mode

1. Mode Switching

Short press the mode key to switch arbitrarily between constant speed mode, fluctuation mode and stairway mode.

2. Mode Introduction

Constant Speed Mode: Constant speed massage and percussion.

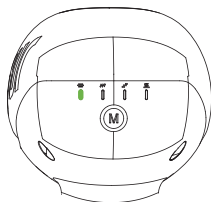

Fluctuation Mode: Switch high and low gear back and forth to massage and percuss.

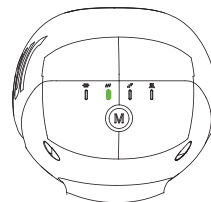

Stairway Mode: Advanced massage and percussion from low to high gear.

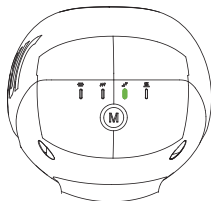

Heating Mode: Constant temperature 40-45°C massage and percussion.

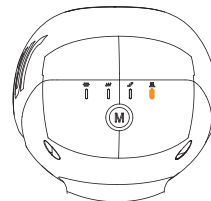

When using the heating mode, please replace the special heating head first, and then long press the mode key to enter the preheating mode (Orange light flashing), after preheating 45s, the heating head enters a constant temperature state (Orange light is always on).

Note: You cannot adjust the speed knob in fluctuation and stairway mode.

3. Intelligent Protection Mode

When the machine detects that a continuous opposite external force is applied to the massage head and exceeds the limit set by the machine, the machine will intelligently identify and stop turning, which can effectively protect the motor and prolong the life of the motor.

● Choose Massage Head

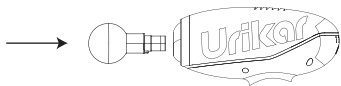

1. Install

Choose the massage head you needed and insert by pressing in, remove by pulling it out.

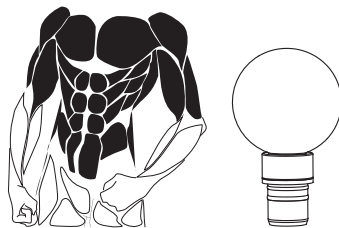

2. Introduction of Massage Head

A. Ball Head: Uniform and soft strength suitable for whole body muscle massage and relaxation.

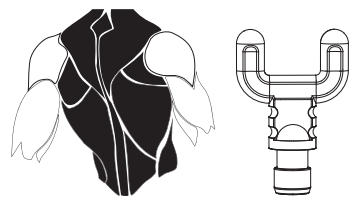

B. U-Shaped Head: Suitable for shoulders, cervical vertebrae and bilateral muscles.

Note: Don't directly hit the cervical spine and spine, it will cause personal injury.

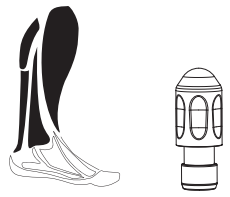

C. Bullet Head: Suitable for tendon, acupoint, etc.

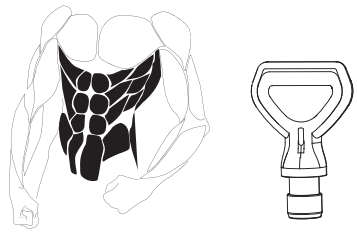

D. D-Shaped Head: Suitable for back, cervical and waist massage.

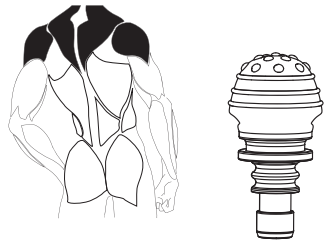

E. Air Plug Head: Suitable for massaging bones and sensitive parts.



F. Flat Head: Suitable for relaxation and plasticity of various muscle parts of the body.

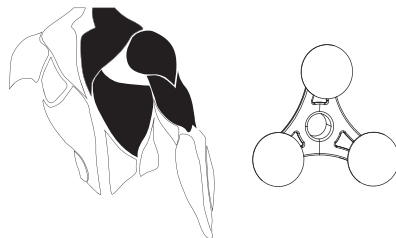

G. Triangular Soft Head: Suitable for shoulder massage and relaxation.

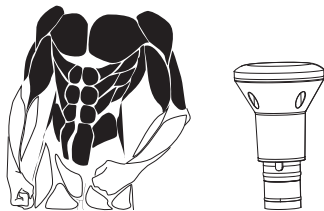

H. Heating Head: It can promote the decomposition of lactic acid after exercise when heated, and is suitable for whole body muscle massage and relaxation.

● Charging

1. How to Charge

Use the included power adapter to connect the charging port and power supply of the massage gun.

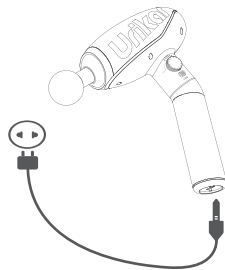

2. Description of Battery Indicator

A. Low Battery Display: Battery <20%, red light is on.

B. Charging Display: Green light flashes.

C. Fully Charged Display: The green light is always on.

Note: This product cannot be turned on to use when charging.



 < 20%



 > 20%

Parameter Information

Name: Massage gun

Brand: Urikar

Model: Pro 1

Size: 268*292*93mm

Weight: 1.2kg

Input Voltage: 100-240V, 50/60Hz

Rated Current: About 1000 mA

Rated Power: 30W

Work Mode: Constant speed mode, fluctuation mode, stairway mode, heating mode

Power Supply: 2600 mAh rechargeable lithium battery

INHALTS

1. Was ist in der Box	08
2. Einführung von Pro 1	08
3. Wie zu benutzen	09
• Verwendung der Pro 1	
• Auswahl des Griffwinkel	
• Auswahl der Modi	
• Auswahl der Massageköpfe	
• Aufladen	
4. Parameterinformationen	14

Was ist in der Box

DE

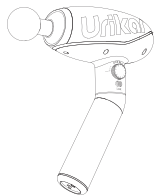

Urikar Massagepistole Pro 1 x1



Massageköpfe x8

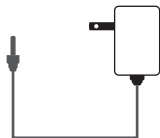

Netzteil x1



Bedienungsanleitung x1

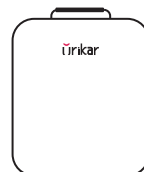

Handtasche x1

Einführung von Pro 1

- ①. Berührungsempfindlicher Bereich
- ②. Netzschalter
- ③. Modusschaltertaste | Modusanzeige
- ④. Geschwindigkeitsregler
- ⑤. Griff-Dreh Knopf
- ⑥. Geschwindigkeitsanzeige
- ⑦. Betriebsanzeige und Batterieanzeige
- ⑧. DC Eingangsanschluss

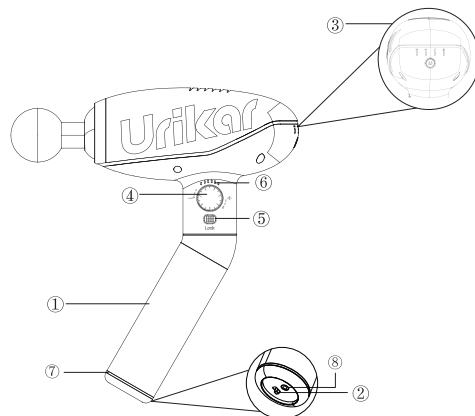

Wie zu benutzen

● Verwendung der Pro 1

1. Schalten Sie den Netzschalter ② ein und halten Sie den Griff (Berührungsempfindlicher Bereich ①) gedrückt. Die Massagepistole wird eingeschaltet.

Hinweis: Die Betriebsanzeige ⑦ leuchtet blau und dreht sich einmal, während der Griff vibriert.

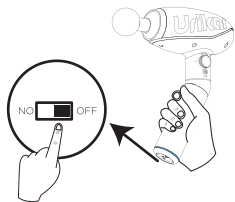

3. Legen Sie den Griff hin und die Massagepistole stoppt automatisch.

Hinweis: Wenn es längere Zeit nicht benutzt wird, schalten Sie bitte den Netzschalter aus.

● Auswahl des Griffwinkels

Halten Sie den Griff-Dreh Knopf ⑤ gedrückt, um den Winkel des Griffs (um 180 ° drehbar) zu ändern. Dies ist praktisch, um die Rückenmuskulatur zu massieren.

Hinweis: Sie können ein Klicken hören, wenn die Drehung abgeschlossen ist.

2. Stellen Sie den Geschwindigkeitsregler ④ ein und die Massagepistole beginnt zu arbeiten (Stellen Sie den Modus und die Geschwindigkeit entsprechend Ihrem Körperbau und Ihren Vorlieben ein).

Geschwindigkeitsknopf: 0-6 Gang, drehen Sie im Uhrzeigersinn, um die Geschwindigkeit zu erhöhen, gegen den Uhrzeigersinn, um zu verringern, und stellen Sie den niedrigsten Gang für den Standby-Modus ein.

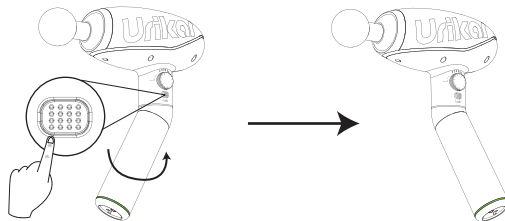
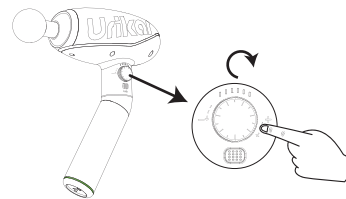

• Modusumschaltung

1. Modusumschaltung

Drücken Sie kurz die Modusschaltertaste, um willkürlich zwischen Konstantgeschwindigkeitsmodus, Schwankungsmodus und Treppenmodus umzuschalten.

2. Einführung der Modi

Konstantgeschwindigkeitsmodus: Massieren und Schlagen mit konstanter Geschwindigkeit.

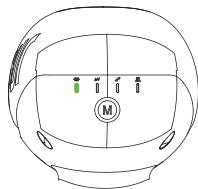

Schwankungsmodus: Schalten Sie den hohen und niedrigen Gang hin und her, um zu massieren und zu schlagen.

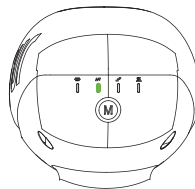

Treppenmodus: Fortgeschrittene Massage und Perkussion von niedrigem bis hohem Gang.

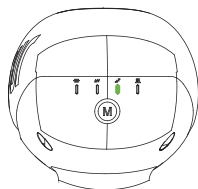

Heizmodus: Massage und Perkussion mit konstanter Temperatur von 40 bis 45 °C.

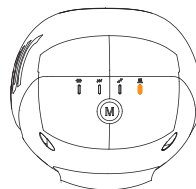

Wenn Sie den Heizmodus verwenden, tauschen Sie bitte den speziellen Heizkopf aus, drücken Sie lange die Modustaste (orangefarbenes Licht blinkt), nach dem Vorheizen von 45 sekunde tritt der Heizkopf in einem Zustand mit dem konstanten Temperatur(orangefarbenes Licht blinkt).

Hinweis: Sie können den Geschwindigkeitsregler nicht im Schwankungs- und Treppenmodus einstellen.

3. Intelligenter Schutzmodus

Wenn die Maschine feststellt, dass eine kontinuierliche entgegengesetzte äußere Kraft auf den Massagekopf ausgeübt wird und die von der Maschine festgelegte Grenze überschreitet, erkennt die Maschine intelligent und stoppt das Drehen, wodurch der Motor wirksam geschützt und die Lebensdauer des Motors verlängert werden kann.

• Auswahl der Massageköpfe

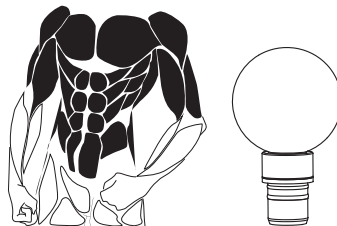
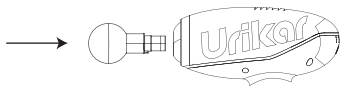

1. Installieren

Wählen Sie den gewünschten Massagekopf und setzen Sie ihn durch Drücken ein. Entfernen Sie ihn durch Herausziehen.

2. Einführung der Massageköpfe

A. Runde Kopf: Gleichmäßige und weiche Kraft, geeignet für Ganzkörpermuskelmassage und Entspannung.

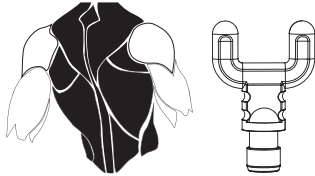

B. U-förmiger Kopf: Geeignet für Schultern, Halswirbel und bilaterale Muskeln.

Hinweis: Schlagen Sie nicht direkt auf die Halswirbelsäule und die Wirbelsäule, da dies zu Verletzungen führen kann.

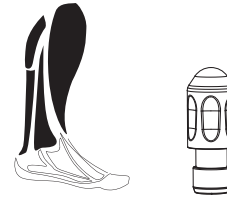

C. Kugelkopf: Geeignet für Sehnen, Akupunkturpunkte usw.

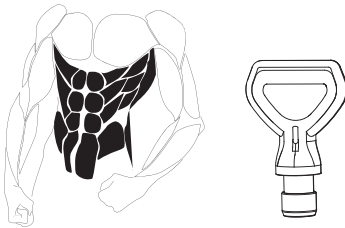

D. D-förmiger Kopf: Geeignet für Rücken-, Gebärmutterhals- und Taillenmassage.

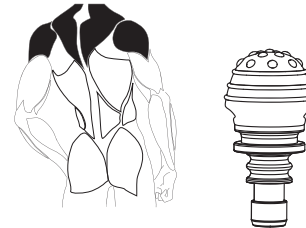

E. Luftstopfkopf: Geeignet zum Massieren von Knochen und empfindlichen Teilen.



F. Flachkopf: Geeignet zur Entspannung und Plastizität verschiedener Muskelpartien des Körpers.

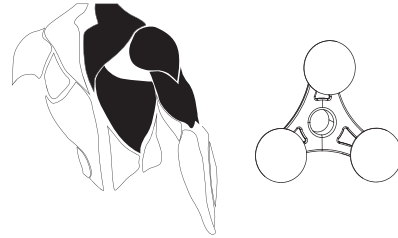

G. Dreieckiger weicher Kopf: Geeignet für Massage und Entspannung von Schulter.

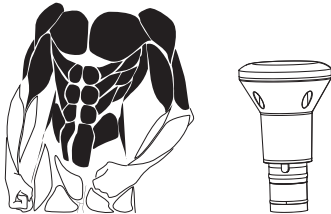

H. Heizkopf: Es kann die Zersetzung von Milchsäure nach dem Training beim Erhitzen fördern und eignet sich für die Ganzkörpermuskelmassage und -entspannung.

• Aufladen

1. Wie zu aufladen

Verwenden Sie das mitgelieferte Netzteil, um den Ladeanschluss und die Stromversorgung der Massagepistole anzuschließen.

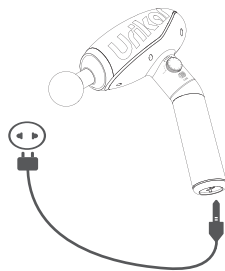

2. Beschreibung der Batterieanzeige

- A. Anzeige der niedrigen Batterie: Batterie <20%, rotes Licht leuchtet.
- B. Anzeige der Aufladung: Das grüne Licht blinkt
- C. Voll aufgeladener Anzeige: Das grüne Licht leuchtet immer.

Hinweis: Dieses Produkt kann beim Laden nicht eingeschaltet werden.



 < 20%

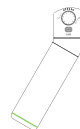

 > 20%

Parameterinformationen

Name: Massagepistole

Marke: Urikar

Modell: Pro 1

Größe: 268 * 292 * 93 mm

Gewicht: 1,2 kg

Eingangsspannung: 100-240 V, 50/60 Hz

Nennstrom: ca. 1000 mAh

Nennleistung: 30W

Arbeitsmodus: Konstantgeschwindigkeitsmodus, Schwankungsmodus, Treppenmodus, Heizmodus

Stromversorgung: 2600 mAh wiederaufladbare Lithiumbatterie

CONTENU

1. Qu'y a-t-il dans la boîte?	15
2. Instructions de Pro 1	15
3. Comment l'utiliser?	16
• Utilisation de Pro 1	
• Réglage de l'Angle de Poignée	
• Sélection de Mode	
• Sélection de Tête de Massage	
• Instructions de Charge	
4. Spécifications	21

Qu'y a-t-il dans la boîte?

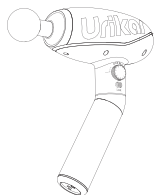

Urikar Pro 1 Pistolet de Massage Musculaire x1



Têtes de Massage x8

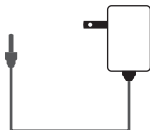

Chargeur x1



Manuel d'Utilisation x1



Sac à Main x1

FR

Instructions de Pro 1

- ① Zone Tactile
- ② Interrupteur d'Alimentation
- ③ Touche de Mode | Indicateur de Mode
- ④ Bouton de Vitesse
- ⑤ Bouton de Rotation de la Poignée
- ⑥ Indicateur de Niveau de Vitesse
- ⑦ Indicateur de Batterie
- ⑧ Port d'Entrée DC

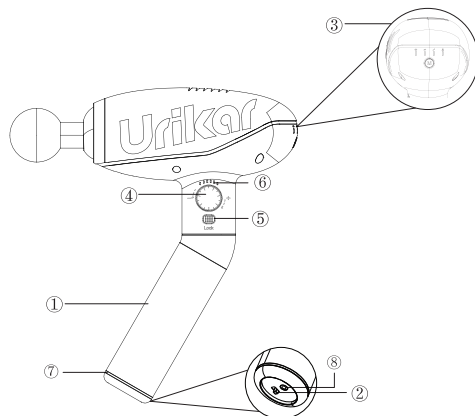

Comment l'utiliser?

• Utilisation de Pro 1

1. Allumez l'Interrupteur d'Alimentation ② et maintenez la poignée (Zone Tactile ①), et le pistolet de massage musculaire s'allumera.

Remarque: Indicateur d'Alimentation ⑦ allume la lumière bleue et tourne une fois, et la poignée vibre.

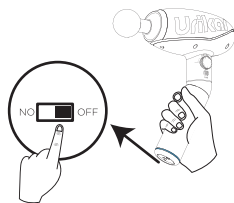

3. Relâchez la poignée et le pistolet à massage musculaire cesse automatiquement de fonctionner.

Remarque: s'il n'est pas utilisé pendant une longue période, veuillez désactiver.

• Réglage de l'Angle de Poignée

Appuyez le bouton de rotation de la poignée ⑤ pour changer l'angle de la poignée (rotatif à 180 °), ce qui est pratique pour masser les muscles du dos.

Remarque: Vous pouvez entendre un clic lorsque la rotation est terminée.

2. Réglez le Bouton de Vitesse ④ et le pistolet de massage musculaire commence à fonctionner (Ajustez le mode et la vitesse en fonction de votre physique et de vos préférences).

Bouton de Vitesse: vitesse 0-6, tournez dans le sens horaire pour augmenter, dans le sens antihoraire pour diminuer, ajustez la vitesse la plus basse pour la veille.

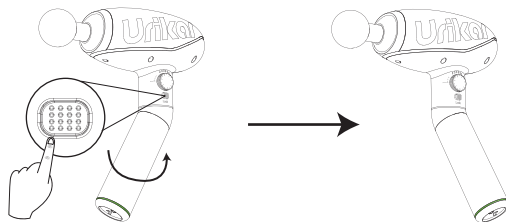
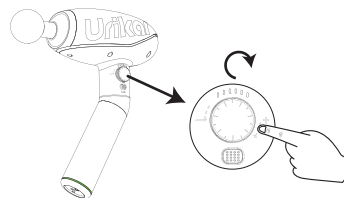

● Sélection de Mode

1. Commutation de Mode

Appuyez brièvement sur la Touche Mode pour basculer arbitrairement entre le Mode de Vitesse Constante, le Mode Fluctué et le Mode Graduel.

2. Introduction des Modes

Mode de Vitesse Constante: Massage et percussion à vitesse constante.

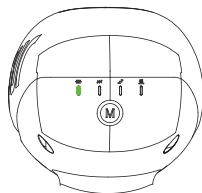

Mode Fluctué: Massage et percussion à vitesse alternative haute et basse.

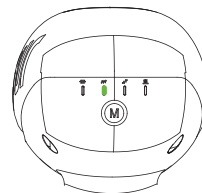

Mode Graduel: Massage et percussion à vitesse augmenté de bas en haut.

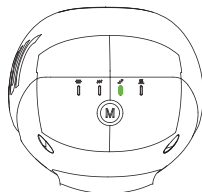

Mode de Chauffage: Massage et percussion à température constante 40-45 C.

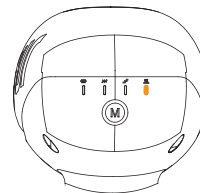

Lorsque vous utilisez le Mode de Chauffage, veuillez remplacer la tête de chauffage spéciale. Appuyez longuement sur la Touche Mode pour passer en Mode de Préchauffage (le voyant orange clignote), après un préchauffage de 45 secondes, la Tête de Chauffe passe en Mode de Température Constante (le voyant orange toujours allumé).

3. Mode de Protection Intelligent

Lorsque la machine détecte qu'une force externe opposée continue est appliquée à la tête de massage et dépasse la limite définie par la machine, la machine identifie et arrête de tourner intelligemment, ce qui peut protéger efficacement la machine et prolonger la durée de vie du moteur.

● Sélection de Tête de Massage

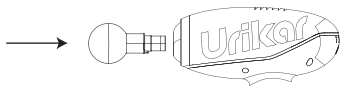

1. L'Installation

Choisissez la tête de massage dont vous avez besoin et insérez-la en appuyant dessus, retirez-la en tirant dessus.

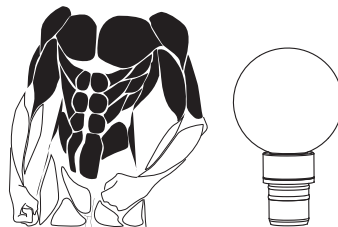

2. Introduction de la Tête de Massage

A. Tête Ronde: Force uniforme et douce adaptée au massage et à la relaxation des muscles du corps entier.

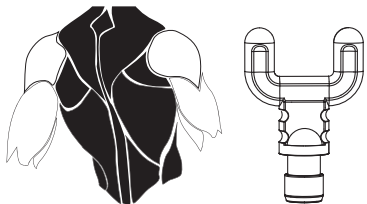

B. Tête en Forme de U: Convient aux épaules, aux vertèbres cervicales et aux muscles bilatéraux.

Remarque: Ne tapez pas directement la colonne cervicale et la colonne vertébrale, cela pourrait causer des blessures.

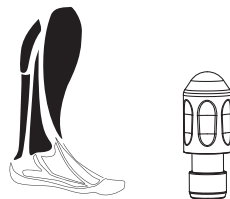

C. Tête de Balle: Convient pour tendon, point d'acupuncture, etc.

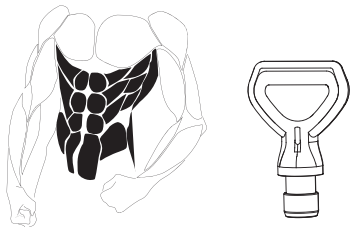

D. Tête de Pelle: Convient pour le massage du dos, du col et de la taille.

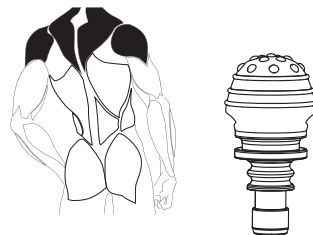

E. Tête en Forme de Champignon: Convient pour masser les os et les parties sensibles.



F. Tête Plate: Convient pour la relaxation et la plasticité de diverses parties musculaires du corps.

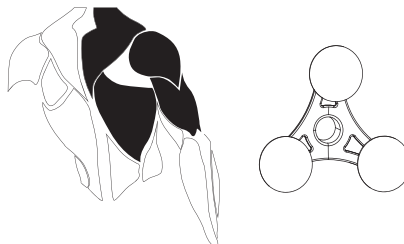

G. Tête Triangulaire Souple: Convient pour le massage et la relaxation des épaules .

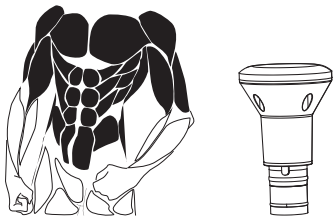

H. Tête de Chauffage: Il peut favoriser la décomposition de l'acide lactique après l'exercice lorsqu'il est chauffé, et convient au massage et à la relaxation des muscles du corps entier.

● Charge

1. Instructions de Charge

Utilisez l'adaptateur secteur inclus pour connecter le port de charge du pistolet de massage et l'alimentation électrique.

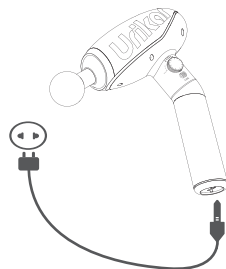

2. Description de l'Indicateur de Batterie

- A. Affichage de Batterie Faible: Puissance <20%, le voyant rouge allumé.
- B. Affichage de Charge: le voyant vert clignote.
- C. Affichage de 100% Charge: le voyant vert toujours allumé.

Remarque: ce produit ne peut pas être allumé lors de la charge.



 < 20%

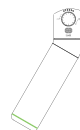

 > 20%

Spécifications

Nom: Pistolet de Massage Musculaire

Marque: Urikar

Modèle: Pro 1

Taille: 268 * 292 * 93mm

Poids: 1,2 kg

Tension d'Entrée: 100-240V, 50 / 60Hz

Courant Nominal: environ 1000 mAh

Puissance Nominale: 30W

Modes de Travail: Mode de Vitesse Constante, Mode Fluctué, Mode

Graduel, Mode de Chauffage

Alimentation: Batterie au lithium rechargeable de 2600 mAh

ÍNDICE

1. Qué hay en la caja	22
2. Introducción de la Pro 1	22
3. Cómo lo usa	23
• Use la Pro 1	
• Elija el ángulo de la manija	
• Elija Modos	
• Elija los Cabezales de Masaje	
• Carga	
4. Características	28

Qué hay en la caja



Urikar Pistola de Masaje Pro 1 x1



Cabezales de Masaje x8

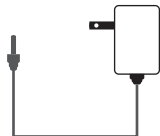

Cargador x1



Manual de Usuario x1



Bolsa x1

Introducción de la Pro 1

- ① Área de Control Táctil
- ② Interruptor de Potencia
- ③ Botón de Modos / Indicador de Modos
- ④ Perilla de Velocidad
- ⑤ Botón de rotación de la manija
- ⑥ Indicador de Nivel de Velocidad
- ⑦ Indicador Encendido e Indicador de Batería
- ⑧ Entrada de DC

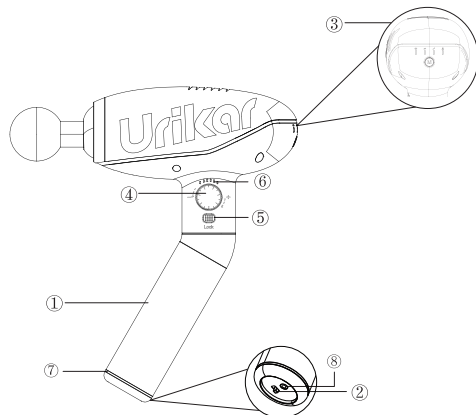

Cómo lo usa

● Use la Pro 1

1. Encienda el interruptor ② y sostenga la manija (área de control táctil ①), y la pistola de masaje se encenderá.

Nota: El indicador de encendido ⑦ se iluminará en azul y girará, al mismo tiempo, el mango vibra una vez.

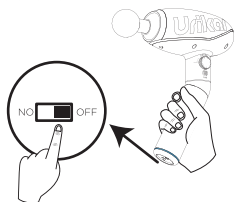

3. Baje el mango y la pistola de masaje dejará de funcionar automáticamente.

Nota: Si no lo usa durante mucho tiempo, recuerde apagar el interruptor de alimentación.

● Elija el ángulo de la manija

Mantenga pulsado el botón de rotación de la manija ⑤ para cambiar el ángulo del mango (giratorio 180 °), lo cual es más conveniente para masajear los músculos de la espalda.

Nota: Escucha un clic cuando se completa la rotación.

2. Ajuste la perilla de velocidad ④, y la pistola de masaje comenzará a funcionar (ajuste el modo y la velocidad de acuerdo con sus necesidades y preferencias).

Perilla de velocidad: Nivel 0-6, gire en sentido horario para aumentar el nivel, en sentido antihorario para disminuirlo y ajustarlo más bajo hasta el modo de espera.

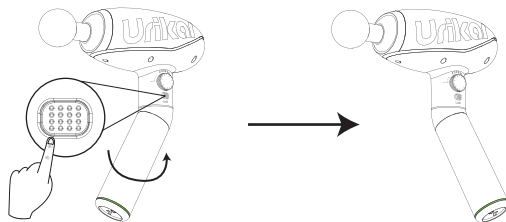
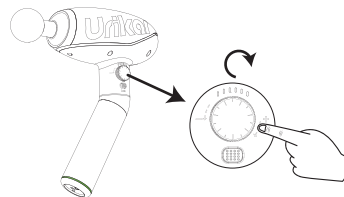

● Elija Modos

1. Cambio de modo

Pulse brevemente el botón de modo para cambiar arbitrariamente entre el modo de velocidad constante, el modo de fluctuación y el modo de escalera.

2. Introducción a los modos

Modo de Velocidad Constante: masaje y percusión a velocidad constante.

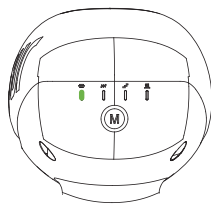

Modo de Fluctuación: masaje y percusión de niveles diferentes de ida y vuelta.

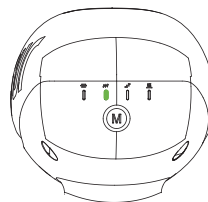

Modo de Escalera: masaje y percusión a nivel aumentado progresivamente de velocidad bajo a alto.

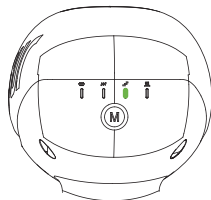

Modo de Calentamiento : masaje y percusión a temperatura constante 40-45 C .

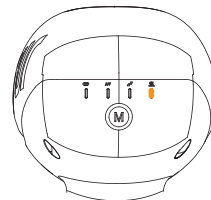

Cuando quiere usar la pistola de masaje en el modo de calentamiento, reemplace primero el cabezal de calentamiento especial y luego pulse prolongadamente el botón de modo para entrar al proceso de precalentamiento (luz naranja parpadeante), después de precalentar por 45 segundos, el cabezal de calentamiento entra en un estado de temperatura constante (la luz naranja siempre encendida).

Nota: No puede ajustar la velocidad por la perilla en el modo de fluctuación y de escalera.

3. Protección inteligente

Cuando la máquina detecta que se aplica una fuerza externa opuesta continua al cabezal de masaje y excede el límite establecido por la máquina, la pistola de masaje identificará de forma inteligente y detendrá el giro, lo que puede proteger eficazmente el motor y prolongar su vida útil.

● Elija los Cabezales de Masaje

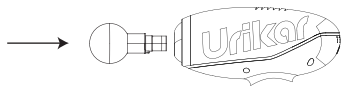

1. Instalación

Elija el cabezal de masaje que necesita e insértelo presionando. Cuando necesite quitarlo, retire tirando de él.

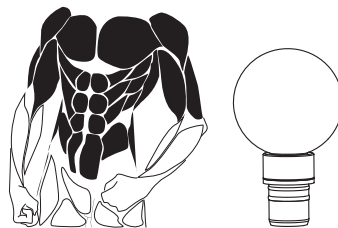

2. Introducción de los Cabezales de Masaje

A. Cabezal Redondo: Fuerza uniforme y suave, adecuado para el masaje muscular y la relajación de todo el cuerpo.

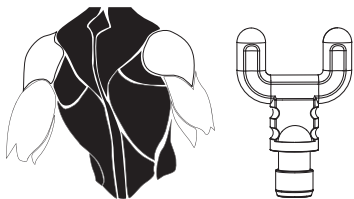

B. Cabezal de Forma-U: adecuado para hombros, vértebras cervicales y músculos bilaterales.

Nota: No lo use directamente a la columna cervical y la columna vertebral, se puede causar daños personales.

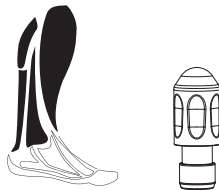

C. Cabezal de Bala: adecuado para tendones, puntos de acupuntura, etc.

ES

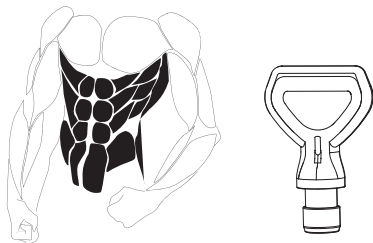

D. Cabezal de Forma-D: Adecuado para el masaje de espalda, cervical y cintura.

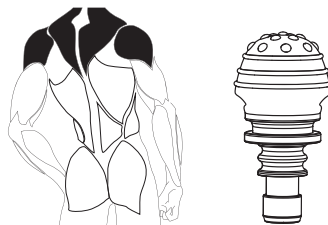

E. Cabezal de Aire: adecuado para el masaje de espueleto y partes sensibles.



F. Cabezal Plano: adecuado para la relajación y la plasticidad de varias partes musculares del cuerpo.

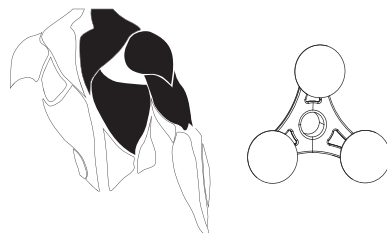

G. Cabezal Suave Triangular: adecuado para el masaje y la relajación de hombros.

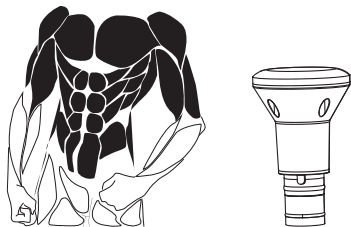

H. Cabezal Calefactor: puede promover la descomposición del ácido láctico después del ejercicio cuando se calienta, y es adecuado para el masaje muscular y la relajación de todo el cuerpo.

● Carga

1. Cómo se carga

Conecte la pistola de masaje con el cargador en el paquete y enchúfelo a la alimentación.

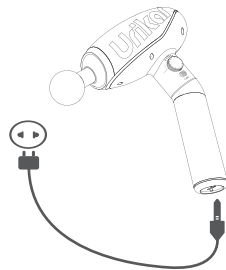

2. Descripción del indicador de batería

- A. Presentación de batería baja: batería <20%, luz roja se enciende.
- B. Presentación durante la carga: la luz verde parpadea.
- C. Presentación de carga completa: la luz verde está encendida siempre.

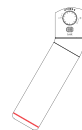

 < 20%



 > 20%

Nota: El producto no se puede usar mientras se carga.

Características

Nombre: Pistola de masaje

Marca: Urikar

Modelo: Pro 1

Tamaño: 268 * 292 * 93 mm

Peso: 1,2 kg

Voltaje de entrada: 100-240 V, 50 / 60Hz

Corriente nominal: alrededor de 1000 mA

Potencia RMS: 30 W

Modo de trabajo: modo de velocidad constante, modo de fluctuación, modo de escalera, modo de calefacción

Fuente de alimentación: batería de litio recargable de 2600 mAh

CONTENUTI

1. Cosa c'è nella scatola?	29
2. Introduzione di Pro 1	29
3. Come si usa?	30
• Uso di Pro 1	
• Scegliere l'angolazione della maniglia	
• Scegliere le modalità	
• Scegliere le testine della Pistola	
• Ricarica	
4. Informazioni sui parametri	35

Cosa c'è nella scatola

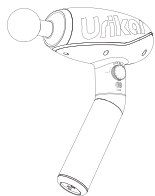

Urikar Massage Gun Pro 1 x1



Testine di massaggio x8

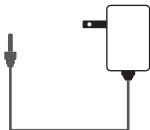

Caricatore x1



Manuale dell'utente x1



Borsetta x1

Introduzione di Pro 1

- ① Toccare Area di rilevamento
- ② Interruttore di alimentazione
- ③ Tasto modalità | Indicatore di modalità
- ④ Manopola di velocità
- ⑤ Pulsante di rotazione della maniglia
- ⑥ Indicatore di livello di velocità
- ⑦ Indicatore di alimentazione e indicatore di batteria
- ⑧ Porta di ingresso CC

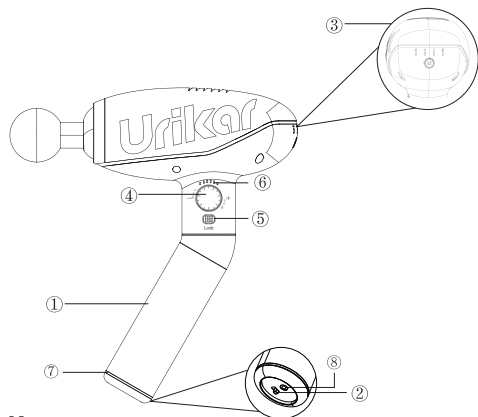

Come si usa?

● Usa il Pro 1

1. Accendere l'interruttore di alimentazione ② e tenere la maniglia (Toccare Area di rilevamento ①) e la pistola massaggiante si accenderà.

Nota: l'indicatore di alimentazione ⑦ si illuminerà di blu e ruoterà una volta, mentre la maniglia vibra.

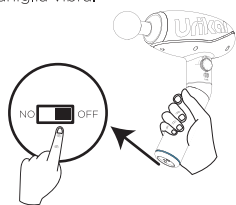

3. Abbassare la maniglia e la pistola massaggiante smette di funzionare automaticamente.

Nota: Se non viene utilizzato per un lungo periodo, spegnere l'interruttore di alimentazione.

● Scegliere l'angolazione della maniglia

Tenere premuto il pulsante di rotazione della maniglia ⑤ per modificare l'angolazione della maniglia (ruotabile di 180°). Questo è utile per massaggiare i muscoli della schiena.

Nota: Al termine della rotazione, si sentirà un clic.

2. Regola la manopola della velocità ④ e la pistola da massaggio inizia a funzionare (regola la modalità e la velocità in base al tuo fisico e alle tue preferenze).

Manopola di velocità: 0-6 marce, ruota in senso orario per aumentare la marcia, in senso antiorario per diminuire, e regola la marcia più bassa per l'attesa.

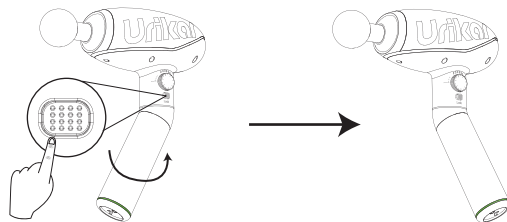
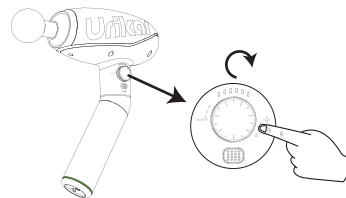

● Scegliere le modalità

1. Cambio di modalità

Premere brevemente il tasto modalità per alternare arbitrariamente tra modalità a velocità costante, modalità di fluttuazione e modalità scala.

2. Introduzione delle modalità

Modalità a velocità costante: Massaggio a velocità costante e percussioni.

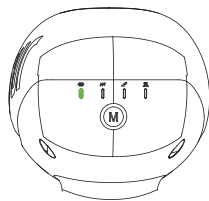

Modalità fluttuazione: Cambia marcia alta e bassa avanti e indietro per massaggio e percussioni.

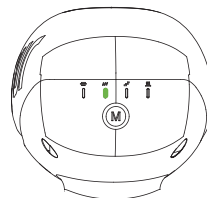

Modalità scala: Massaggio avanzato e percussioni da marcia bassa a marcia alta.

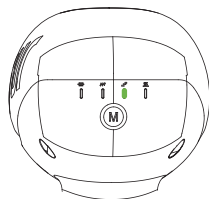

Modalità di riscaldamento: Massaggio e percussioni a temperatura costante 40-45 °C.

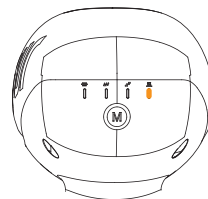

Quando si utilizza la modalità di riscaldamento, sostituire prima la testa di riscaldamento speciale, quindi premere a lungo il tasto modalità per accedere alla modalità di preriscaldamento (luce arancione lampeggiante), dopo il preriscaldamento di 45 secondi, la testa di riscaldamento entra in uno stato di temperatura costante (la luce arancione è sempre accesa).

Nota: Non si può regolare la manopola della velocità in modalità fluttuante e di scala.

3. Modalità di protezione intelligente

Quando la macchina rileva che una forza esterna opposta continua viene applicata alla testina di massaggio e supera il limite impostato dalla macchina, la macchina identificherà e smetterà in modo intelligente di girare, il che può proteggere efficacemente il motore e prolungare la vita del motore.

● Scegliere le teste della Pistola

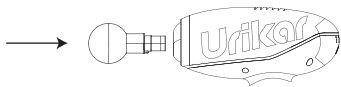

1. Installazione

Scegli la testina di massaggio di cui hai bisogno e inseriscila premendo, rimuovila estraendola.

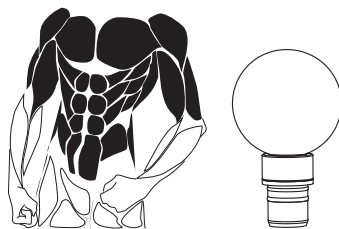

2. Introduzione di Massage Head

A. Testa rotonda: Forza uniforme e morbida adatta al massaggio e al rilassamento dei muscoli di tutto il corpo.

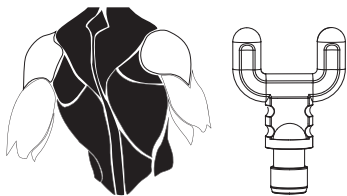

B. Testa a forma di U: Adatta a spalle, vertebre cervicali e muscoli bilaterali.

Nota: Non colpire direttamente la colonna cervicale e la colonna vertebrale, causerà lesioni personali.

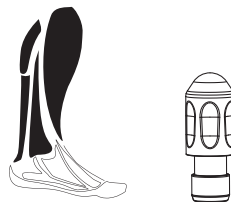

C. Testa a forma di D: Adatta per massaggio schiena, cervicale e vita.

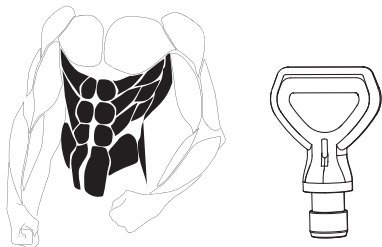

D. D-Shaped Head: Suitable for back, cervical and waist massage.

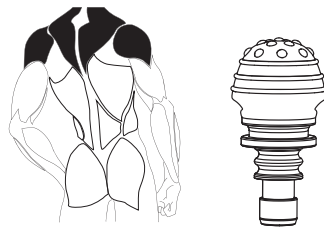

E. Testa della presa d'aria: Adatta per massaggiare ossa e parti sensibili.



F. **Testa piatta:** Adatta per il rilassamento e la plasticità di varie parti muscolari del corpo.

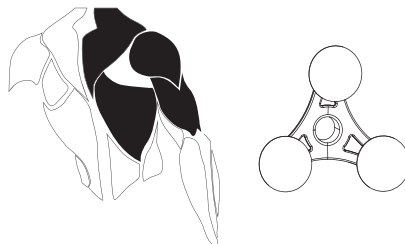

G. **Testa morbida triangolare:** Adatto per massaggio alle spalle e relax.

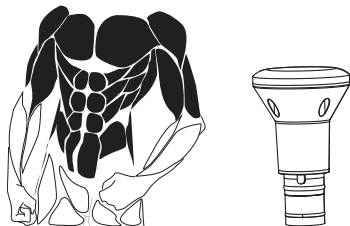

H. **Testa riscaldante:** Può favorire la decomposizione dell'acido lattico dopo l'esercizio fisico quando riscaldato ed è adatto per il massaggio e il rilassamento dei muscoli di tutto il corpo.

● Ricarica

1. Come si carica?

Utilizzare l'adattatore di alimentazione incluso per collegare la porta di ricarica e l'alimentazione della pistola per massaggi.

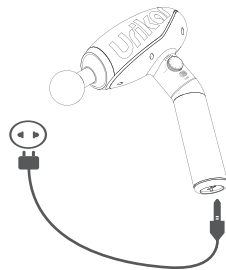

2. Descrizione dell'indicatore della batteria

A. Display batteria scarica: batteria <20%, luce rossa accesa.

B. Display di ricarica: la luce verde lampeggia.

C. Display completamente carico: la luce verde è sempre accesa.

Nota: Il prodotto non si può essere acceso per l'uso durante la ricarica.

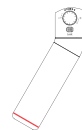

 < 20%



 > 20%

Informazioni sui parametri

Nome: Pistola da massaggio

Marchio: Urikar

Modello: Pro 1

Dimensioni: 268 * 292 * 93mm

Peso: 1,2 kg

Tensione di ingresso: 100-240 V, 50/60 Hz

Corrente nominale: Circa 1000 mAh

Potenza nominale: 30 W

Modalità di lavoro: Modalità a velocità costante, modalità di fluttuazione, modalità scala, modalità riscaldamento

Alimentazione: Batteria al litio ricaricabile da 2600 mAh

目次

1. 同梱物	36
2. 商品紹介	36
3. お使い方	37
• Pro 1を使おう	
• ハンドルの角度を選択	
• モード選択	
• マッサージヘッド	
• 充電	
4. パラメータ情報	42

同梱物

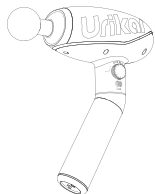

Urikarマッサージガン x1

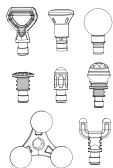

マッサージヘッドx8

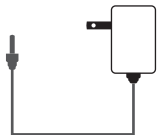

電源アダプターx1

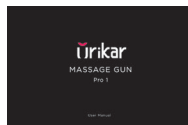

説明書x1



ハンドバックx1

商品紹介

- ① タッチセンサーエリア
- ② 電源スイッチ
- ③ モードキー | モードインジケータ
- ④ スピードノブ
- ⑤ ハンドル回転ボタン
- ⑥ スピードレベルインジケータ
- ⑦ レベルとバッテリーインジケータ
- ⑧ DC入力ポート

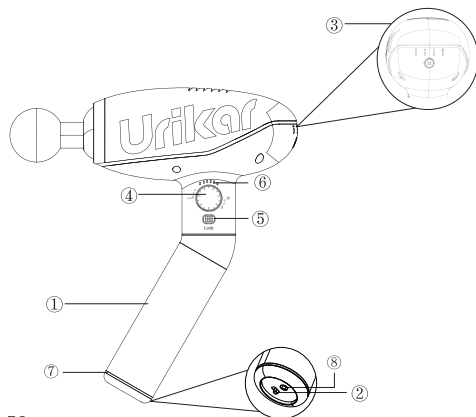

お使い方

● Pro 1を使おう

1. 電源スイッチ②をオンにして、ハンドル(タッチセンシングエリア①)を握むとマッサージガンがオンになります。

注: ハンドルが振動し、電源インジケータ⑦が青につきまして、1週回します。

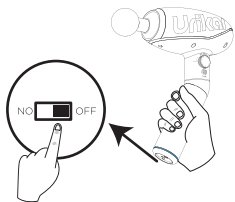

3. ハンドルから手を離れると、マッサージガンが自動的作業を停止します。

注: 長期間使用しない場合は、電源スイッチをオフにしてください。

●ハンドルの角度を選択

ハンドル回転ボタン⑤を押すと、角度を変えられ(180°回転可能)、背中の筋肉をマッサージするので便利です。

注: 回転が完了するとクリック音が聞こえます。

2. スピードノブ④を回すと、マッサージガンが作動し始めます(体格とお好みに応じてモードとスピードを調整してください)。

スピードノブ: 0~6のギア、時計回りに回してギアを増やし、反時計回りに回して減らせます。

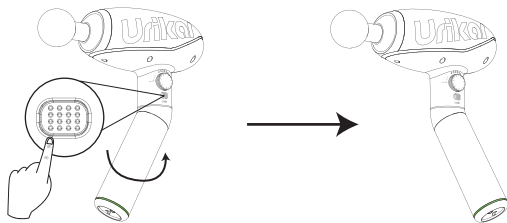
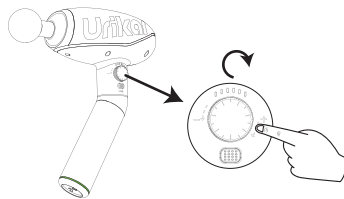

● モード選択

1. モード切り替え

モードキーを短く押すと、定速モード、揺らぎモード、階段モード、加熱モードから任意に切り替えます。

2. モードの紹介

定速モード：定速でマッサージする。

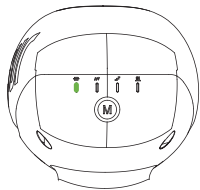

揺らぎモード：低速と高速を切り替えてマッサージする。

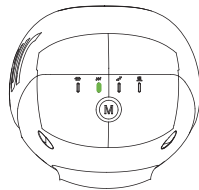

階段モード：低速から高速まで変化し、素晴らしいマッサージする。

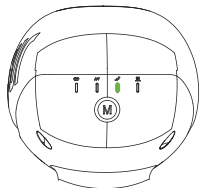

加熱モード：40～45℃でマッサージする。

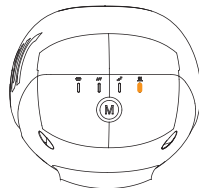

加熱モードを使用する場合は、専用加熱ヘッドを利用し、モードボタンを長押し(オレンジライトが点滅)、加熱インジケーターがオレンジ色に点灯し、予熱モードに入り(オレンジライトが点滅)、45秒間予熱した後、インジケーターがオレンジに点灯し続けて、加熱温度が一定の状態になります。

注:揺らぎモードおよび階段モードでは、速度ノブを調整できません。

3. 知能保護モード

このマッサージガンは、マッサージヘッドに反対で連続的な外力が加えられ、マシンによって設定された制限を超えたことを検出すると、インテリジェントに回転を識別して停止し、モーターを効果的に保護してモーターの使用寿命を延ばします。

● マッサージヘッド

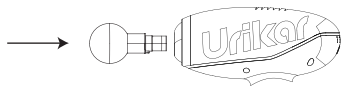

1. ヘッドの組み立て

適切なマッサージヘッドを持って、マッサージガンに押し込むだけで設置完了。そして、ヘッドを握って抜けば取り外せます。

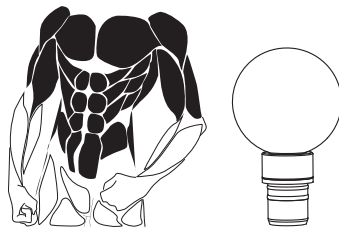

2. マッサージヘッドの紹介

A. ボールヘッド: 均一で柔らかな強度を提供して、全身の筋肉をマッサージやリラクゼーションに適した。

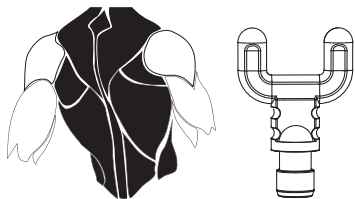

B. U字型ヘッド：肩、頸椎、両側筋に適しています。

注：大怪我を避けるために頸椎や脊椎を直接叩かないでください。

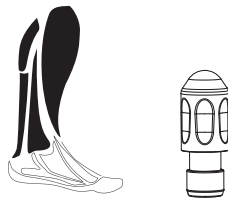

C. 弾丸型ヘッド：腿、ツボなどに適しています。

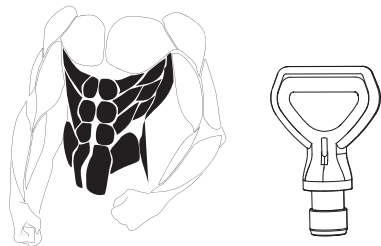

D. D字型ヘッド：背中、頸部、腰のマッサージに適しています。

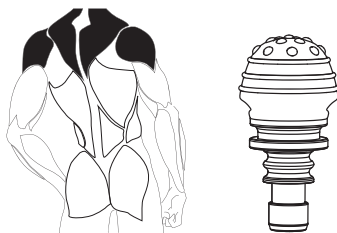

E. エアプラグヘッド：骨や敏感な部分のマッサージに適しています。



F.フラットヘッド：身体のさまざまな筋肉部分のリラクゼーションと可塑性に適しています。

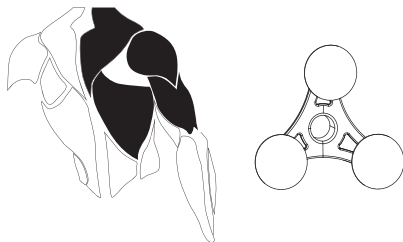

G. 三角形のソフトヘッド：肩のマッサージやリラクゼーションに適しています。

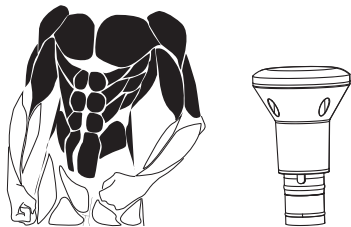

H. ヒーティングヘッド：加熱すると運動後の乳酸分解を促進し、全身の筋肉マッサージやリラククス用に最適です。

● 充電

1. 充電方法

付属の電源アダプタを使用して、マッサージガンの充電ポートと電源を接続します。

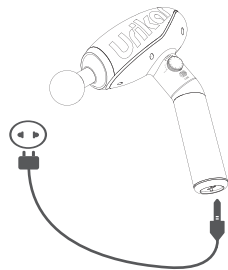

2. バッテリーインジケータの説明

A. 電力不足: バッテリー量 < 20%、ライトが赤く点灯します。

B. 充電中: 緑色のライトが点滅します。

C. 充電完了: 緑色のライトは点灯し続けます。

注: 充電する時、製品を利用できません。



☐ < 20%



☐ > 20%

パラメータ情報

品名: マッサージガン

ブランド: Urikar

モデル: Pro 1

サイズ: 268 * 292 * 93mm

重量: 1.2kg

入力電圧: 100-240V、50 / 60Hz

定格電流: 約1000 mA

定格電力: 30W

仕事モード: 定速モード、変動モード、階段モード、加熱モード

電源: 2600mAh充電式リチウム電池

urikar



support@urikar.com



www.urikar.com



[@UrikarOfficial](https://www.instagram.com/UrikarOfficial)