

XC160 Plus

Receiving Card

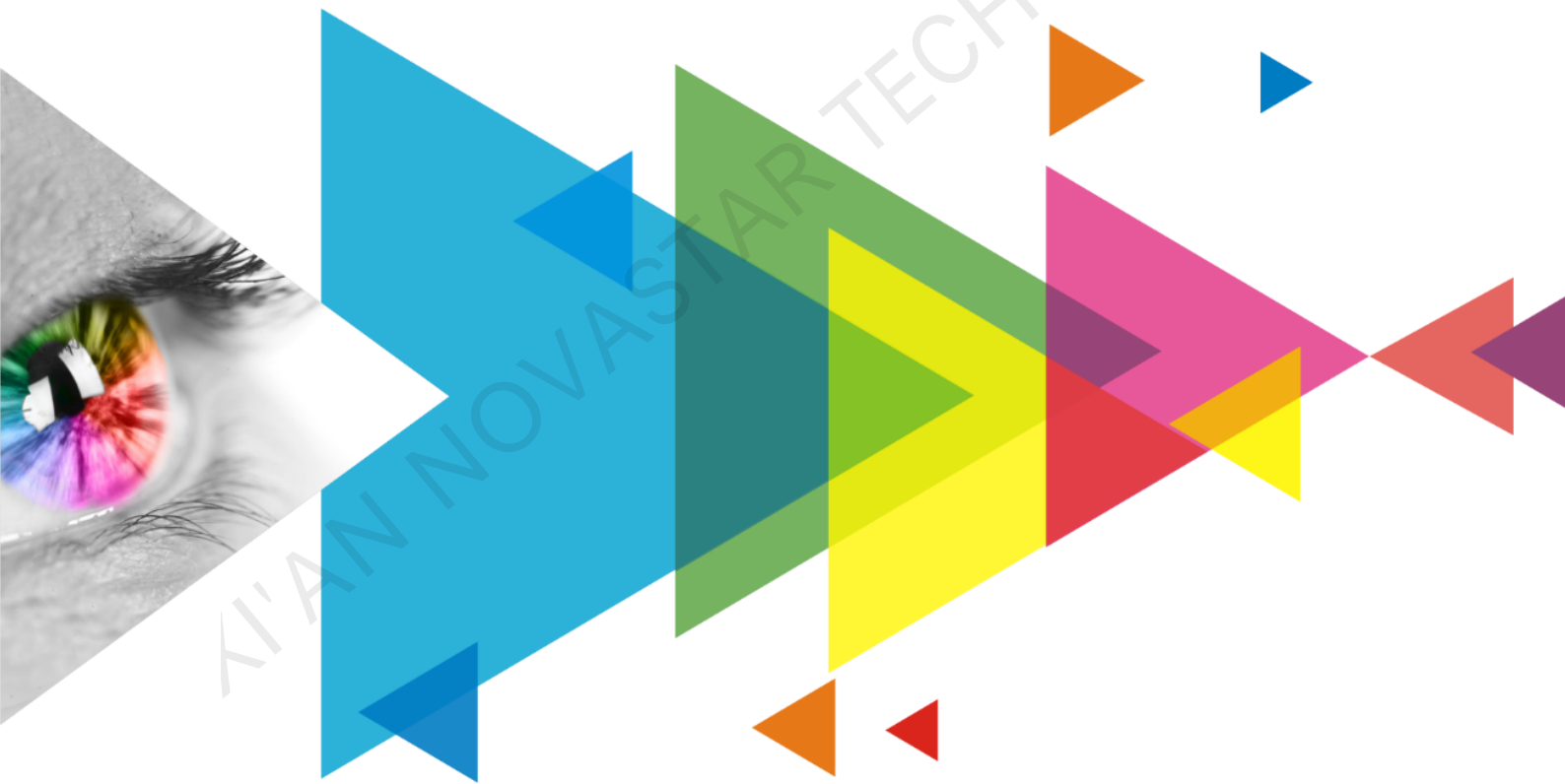

Specifications

Change History

Document Version	Release Date	Description
V1.0.2	2022-03-26	<ul style="list-style-type: none"> Added the dimensions diagram description. Updated the certifications description. Updated some feature descriptions.
V1.0.1	2021-07-30	<ul style="list-style-type: none"> Added the feature of quick uploading of calibration coefficients. Added the certification related description.
V1.0.0	2021-01-26	First release

Introduction

The XC160 Plus is a general small receiving card developed by NovaStar. A single XC160 Plus supports resolutions up to 512x384@60Hz. Supporting various functions such as pixel level brightness and chroma calibration, quick adjustment of dark or bright lines, 3D, individual gamma adjustment for RGB, and image rotation in 90° increments, the XC160 Plus can significantly improve the display effect and user experience.

The XC160 Plus comes with DDR2 connectors for communication, resulting in good compatibility. It supports up to 32 groups of parallel RGB data or 64 groups of serial data (expandable to 128 groups of serial data), and is suitable for various on-site setups.

Certifications

RoHS

If the product does not have the relevant certifications required by the countries or regions where it is to be sold, please contact NovaStar to confirm or address the problem. Otherwise, the customer shall be responsible for the legal risks caused or NovaStar has the right to claim compensation.

Features

Improvements to Display Effect

- Pixel level brightness and chroma calibration
Work with NovaStar's high-precision calibration system to calibrate the brightness and chroma of each pixel, effectively removing brightness differences and chroma differences, and enabling high brightness consistency and chroma consistency.
- Quick adjustment of dark or bright lines
The dark or bright lines caused by splicing of modules or cabinets can be adjusted to improve the visual experience. The adjustment can be easily made and takes effect immediately.
- 3D function
Working with the sending card that supports 3D function, the receiving card supports 3D output.
- Individual gamma adjustment for RGB
Working with NovaLCT (V5.2.0 or later) and the sending card that supports this function, the receiving card supports individual adjustment of red gamma, green gamma and blue gamma, which can effectively control image non-

uniformity under low grayscale and white balance offset, allowing for a more realistic image.

- Image rotation in 90° increments
The display image can be set to rotate in multiples of 90° (0°/90°/180°/270°).

Improvements to Maintainability

- Smart module (dedicated firmware required)
Working with the smart module, the receiving card supports module ID management, storage of calibration coefficients and module parameters, monitoring of module temperature, voltage and flat cable communication status, LED error detection, and recording of the module run time.
- Automatic module calibration
After a new module with flash memory is installed to replace the old one, the calibration coefficients stored in the memory can be automatically uploaded to the receiving card when it is powered on.

- Quick uploading of calibration coefficients
The calibration coefficients can be quickly uploaded to the receiving card, improving efficiency greatly.
- Module Flash management
For modules with flash memory, the information stored in the memory can be managed. The calibration coefficients and module ID can be stored and read back.
- One click to apply calibration coefficients stored in module Flash
For modules with flash memory, if the Ethernet cable is disconnected, users can hold down the self-test button on the cabinet to upload the calibration coefficients in the memory of the module to the receiving card.
- Mapping function
The cabinets can display the receiving card number and Ethernet port information, allowing users to easily obtain the locations and connection topology of receiving cards.
- Setting of a pre-stored image in receiving card
The image displayed on the screen during startup, or displayed when the Ethernet cable is disconnected or there is no video signal can be customized.
- Temperature and voltage monitoring
The receiving card temperature and voltage can be monitored without using peripherals.
- Cabinet LCD
The LCD module of the cabinet can display the temperature, voltage, single run time and total run time of the receiving card.
- Bit error detection
The Ethernet port communication quality of the receiving card can be monitored and the number of erroneous packets can be recorded to help troubleshoot network communication problems.
NovaLCT V5.2.0 or later is required.
- Status detection of dual power supplies
When two power supplies are connected, their working status can be detected by the receiving card.
- Firmware program readback
The receiving card firmware program can be read back and saved to the local computer.
NovaLCT V5.2.0 or later is required.
- Configuration parameter readback
The receiving card configuration parameters can be read back and saved to the local computer.
- LVDS transmission (dedicated firmware required)
Low-voltage differential signaling (LVDS) transmission is used to reduce the number of data cables from the hub board to module, increase the transmission distance, and improve the signal transmission quality and electromagnetic compatibility (EMC).

Improvements to Reliability

- Dual card backup and status monitoring
In an application with requirements for high reliability, two receiving cards can be mounted onto a single hub board for backup. If the main receiving card fails, the backup card can serve immediately to ensure uninterrupted operation of the display.
The working status of the main and backup receiving cards can be monitored in NovaLCT V5.2.0 or later.
- Loop backup
The receiving card and sending card form a loop via the main and backup line connections. If a fault occurs at a location of the lines, the screen can still display the image normally.
- Dual backup of configuration parameters
The receiving card configuration parameters are stored in the application area and factory area of the receiving card at the same time. Users usually use the configuration parameters in the application area. If necessary, users can restore the configuration parameters in the factory area to the application area.
- Dual program backup
Two copies of firmware program are stored in the application area of the receiving card at the factory to avoid the problem that the receiving card may get stuck abnormally during program update.

Appearance

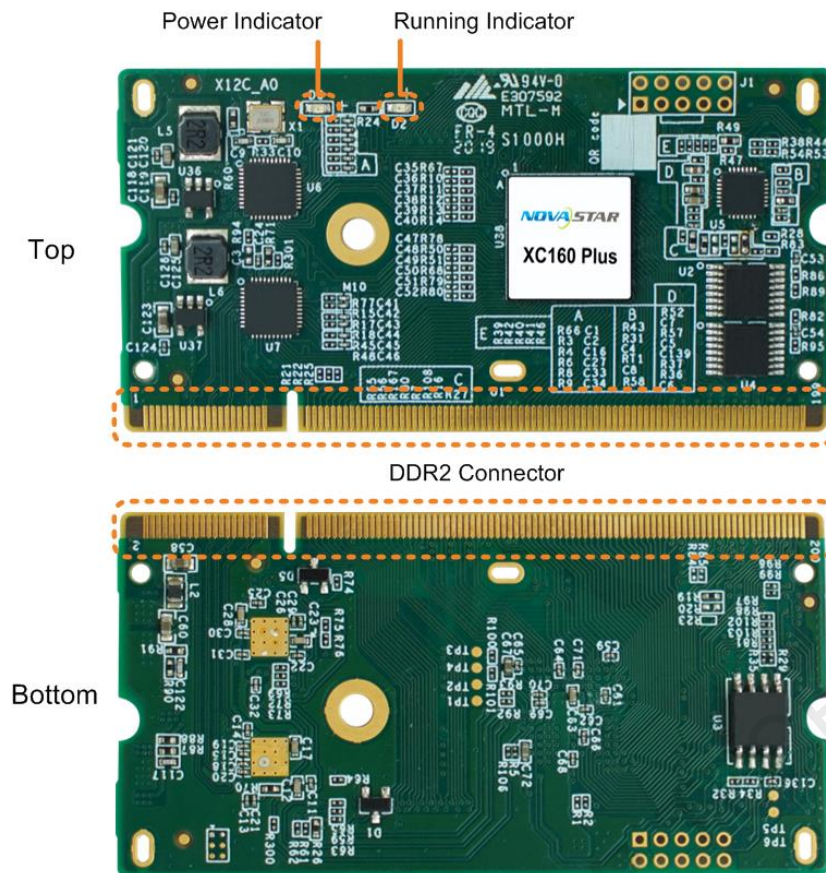

All product pictures shown in this document are for illustration purpose only. Actual product may vary.

Indicators

Indicator	Color	Status	Description
Running indicator	Green	Flashing once every 1s	The receiving card is functioning normally. Ethernet cable connection is normal, and video source input is available.
		Flashing once every 3s	Ethernet cable connection is abnormal.
		Flashing 3 times every 0.5s	Ethernet cable connection is normal, but no video source input is available.
		Flashing once every 0.2s	The receiving card failed to load the program in the application area and is now using the backup program.
		Flashing 8 times every 0.5s	A redundancy switchover occurred on the Ethernet port and the loop backup has taken effect.
Power indicator	Red	Always on	The power input is normal.

Dimensions

The board thickness is not greater than 1.0 mm, and the total thickness (board thickness + thickness of components on the top and bottom sides) is not greater than 6.0 mm. Ground connection (GND) is enabled for mounting holes.

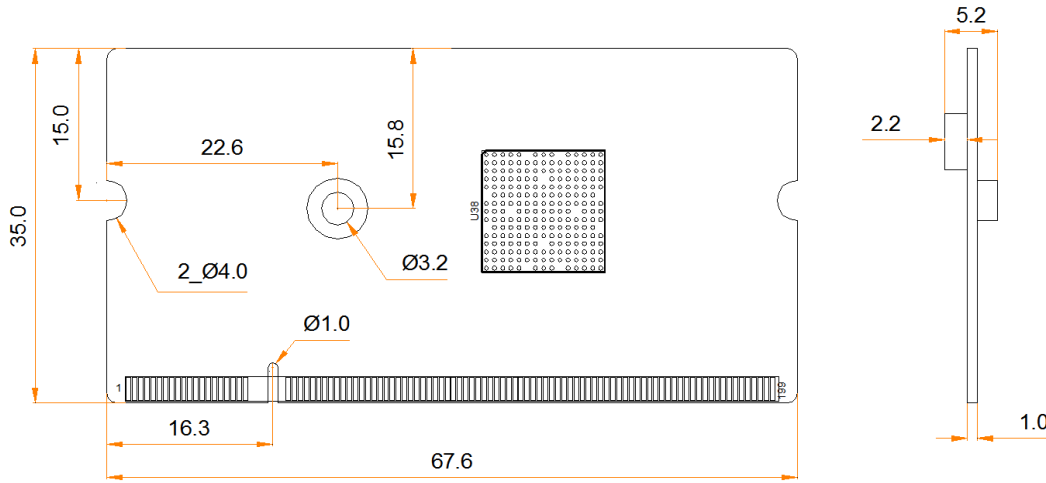

Tolerance: ± 0.3 Unit: mm

To make molds or trepan mounting holes, please contact NovaStar for a higher-precision structural drawing.

XI'AN NOVASTAR TECH CO., LTD.

Pins

32 Groups of Parallel RGB Data

64 Groups of Serial Data

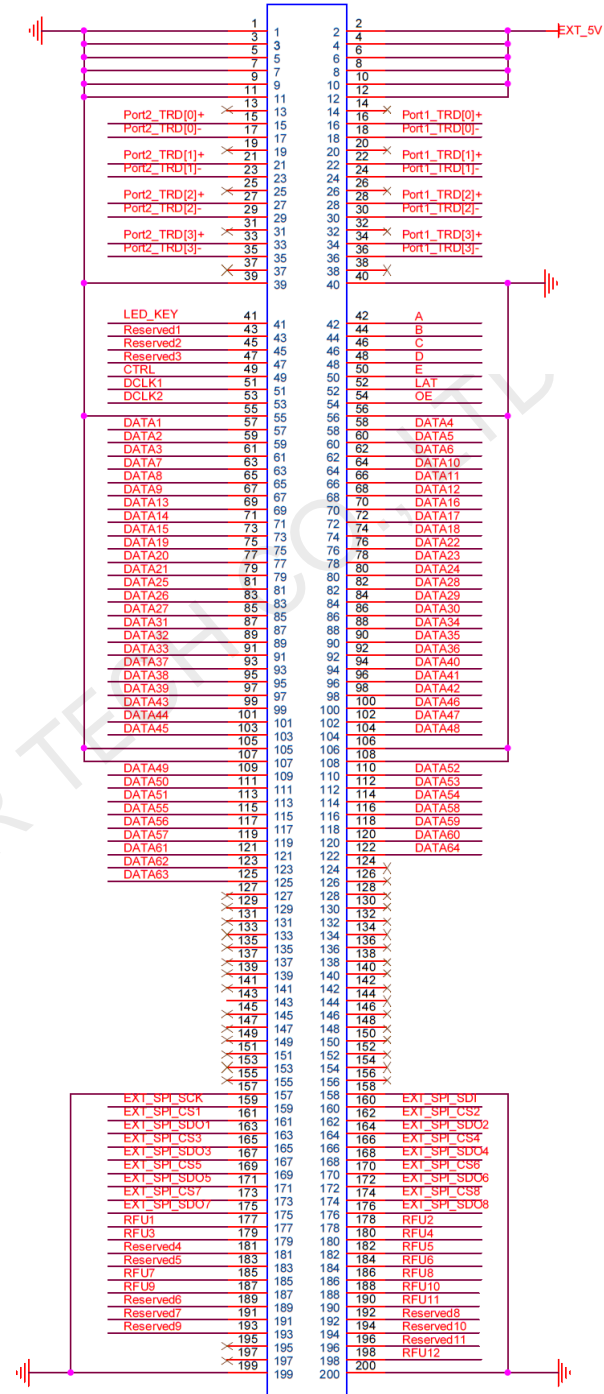
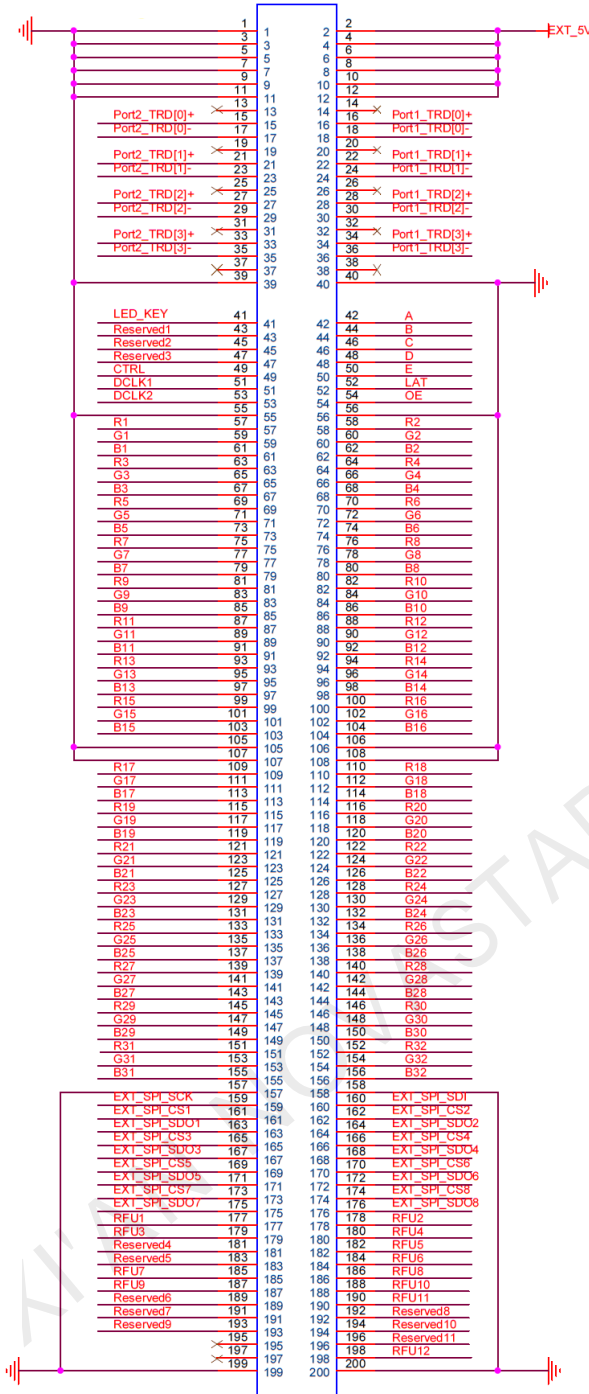

32 Groups of Parallel RGB Data

Pin Description								
GND	1	2	VCC		G15	101	102	G16
GND	3	4	VCC		B15	103	104	B16
GND	5	6	VCC		GND	105	106	GND
GND	7	8	VCC		GND	107	108	GND
GND	9	10	VCC		R17	109	110	R18
NC	13	14	NC		G17	111	112	G18
Port2_TRD[0]+	15	16	Port1_TRD[0]+		B17	113	114	B18
Port2_TRD[0]-	17	18	Port1_TRD[0]-		R19	115	116	R20
					G19	117	118	G20

Pin Description							
NC	19	20	NC	B19	119	120	B20
Port2_TRD[1]+	21	22	Port1_TRD[1]+	R21	121	122	R22
Port2_TRD[1]-	23	24	Port1_TRD[1]-	G21	123	124	G22
NC	25	26	NC	B21	125	126	B22
Port2_TRD[2]+	27	28	Port1_TRD[2]+	R23	127	128	R24
Port2_TRD[2]-	29	30	Port1_TRD[2]-	G23	129	130	G24
NC	31	32	NC	B23	131	132	B24
Port2_TRD[3]+	33	34	Port1_TRD[3]+	R25	133	134	R26
Port2_TRD[3]-	35	36	Port1_TRD[3]-	G25	135	136	G26
NC	37	38	NC	B25	137	138	B26
GND	39	40	GND	R27	139	140	R28
LED_KEY	41	42	A	G27	141	142	G28
Reserved1	43	44	B	B27	143	144	B28
Reserved2	45	46	C	R29	145	146	R30
Reserved3	47	48	D	G29	147	148	G30
CTRL	49	50	E	B29	149	150	B30
DCLK1	51	52	LAT	R31	151	152	R32
DCLK2	53	54	OE	G31	153	154	G32
GND	55	56	GND	B31	155	156	B32
R1	57	58	R2	GND	157	158	GND
G1	59	60	G2	EXT_SPI_SCK	159	160	EXT_SPI_SDI
B1	61	62	B2	EXT_SPI_CS1	161	162	EXT_SPI_CS2
R3	63	64	R4	EXT_SPI_SDO1	163	164	EXT_SPI_SDO2
G3	65	66	G4	EXT_SPI_CS3	165	166	EXT_SPI_CS4
B3	67	68	B4	EXT_SPI_SDO3	167	168	EXT_SPI_SDO4
R5	69	70	R6	EXT_SPI_CS5	169	170	EXT_SPI_CS6
G5	71	72	G6	EXT_SPI_SDO5	171	172	EXT_SPI_SDO6
B5	73	74	B6	EXT_SPI_CS7	173	174	EXT_SPI_CS8
R7	75	76	R8	EXT_SPI_SDO7	175	176	EXT_SPI_SDO8
G7	77	78	G8	RFU1	177	178	RFU2
B7	79	80	B8	RFU3	179	180	RFU4
R9	81	82	R10	Reserved4	181	182	RFU5
G9	83	84	G10	Reserved5	183	184	RFU6
B9	85	86	B10	RFU7	185	186	RFU8
R11	87	88	R12	RFU9	187	188	RFU10
G11	89	90	G12	Reserved6	189	190	RFU11
B11	91	92	B12	Reserved7	191	192	Reserved8
R13	93	94	R14	Reserved9	193	194	Reserved10
G13	95	96	G14	NC	195	196	Reserved11
B13	97	98	B14	NC	197	198	RFU12
R15	99	100	R16	GND	199	200	GND

64 Groups of Serial Data

Pin Description							
GND	1	2	VCC	DATA44	101	102	DATA47
GND	3	4	VCC	DATA45	103	104	DATA48
GND	5	6	VCC	GND	105	106	GND
GND	7	8	VCC	GND	107	108	GND
GND	9	10	VCC	DATA49	109	110	DATA52
GND	11	12	VCC	DATA50	111	112	DATA53
NC	13	14	NC	DATA51	113	114	DATA54
Port2_TRD[0]+	15	16	Port1_TRD[0]+	DATA55	115	116	DATA58
Port2_TRD[0]-	17	18	Port1_TRD[0]-	DATA56	117	118	DATA59
NC	19	20	NC	DATA57	119	120	DATA60
Port2_TRD[1]+	21	22	Port1_TRD[1]+	DATA61	121	122	DATA64
Port2_TRD[1]-	23	24	Port1_TRD[1]-	DATA62	123	124	NC
NC	25	26	NC	DATA63	125	126	NC
Port2_TRD[2]+	27	28	Port1_TRD[2]+	NC	127	128	NC
Port2_TRD[2]-	29	30	Port1_TRD[2]-	NC	129	130	NC
NC	31	32	NC	NC	131	132	NC
Port2_TRD[3]+	33	34	Port1_TRD[3]+	NC	133	134	NC
Port2_TRD[3]-	35	36	Port1_TRD[3]-	NC	135	136	NC
NC	37	38	NC	NC	137	138	NC
GND	39	40	GND	NC	139	140	NC
LED_KEY	41	42	A	NC	141	142	NC

Pin Description							
Reserved1	43	44	B	NC	143	144	NC
Reserved2	45	46	C	NC	145	146	NC
Reserved3	47	48	D	NC	147	148	NC
CTRL	49	50	E	NC	149	150	NC
DCLK1	51	52	LAT	NC	151	152	NC
DCLK2	53	54	OE	NC	153	154	NC
GND	55	56	GND	NC	155	156	NC
DATA1	57	58	DATA4	GND	157	158	GND
DATA2	59	60	DATA5	EXT_SPI_SCK	159	160	EXT_SPI_SDI
DATA3	61	62	DATA6	EXT_SPI_CS1	161	162	EXT_SPI_CS2
DATA7	63	64	DATA10	EXT_SPI_SDO1	163	164	EXT_SPI_SDO2
DATA8	65	66	DATA11	EXT_SPI_CS3	165	166	EXT_SPI_CS4
DATA9	67	68	DATA12	EXT_SPI_SDO3	167	168	EXT_SPI_SDO4
DATA13	69	70	DATA16	EXT_SPI_CS5	169	170	EXT_SPI_CS6
DATA14	71	72	DATA17	EXT_SPI_SDO5	171	172	EXT_SPI_SDO6
DATA15	73	74	DATA18	EXT_SPI_CS7	173	174	EXT_SPI_CS8
DATA19	75	76	DATA22	EXT_SPI_SDO7	175	176	EXT_SPI_SDO8
DATA20	77	78	DATA23	RFU1	177	178	RFU2
DATA21	79	80	DATA24	RFU3	179	180	RFU4
DATA25	81	82	DATA28	Reserved4	181	182	RFU5
DATA26	83	84	DATA29	Reserved5	183	184	RFU6
DATA27	85	86	DATA30	RFU7	185	186	RFU8
DATA31	87	88	DATA34	RFU9	187	188	RFU10
DATA32	89	90	DATA35	Reserved6	189	190	RFU11
DATA33	91	92	DATA36	Reserved7	191	192	Reserved8
DATA37	93	94	DATA40	Reserved9	193	194	Reserved10
DATA38	95	96	DATA41	NC	195	196	Reserved11
DATA39	97	98	DATA42	NC	197	198	RFU12
DATA43	99	100	DATA46	GND	199	200	GND

Reference Design for Extended Functions

Name	Predefinition	Description
RFU1	POWER_STA1	Dual power supply detection signal 1
RFU2	EXT_LCD_BL0	LCD backlight signal 1
RFU3	POWER_STA2	Dual power supply detection signal 2
RFU4	EXT_LCD_CD/RS	LCD RS signal
RFU5	EXT_LCD_SDA/DB1	LCD data signal
RFU6	EXT_LCD_SCL/DB0	LCD clock signal
RFU7	EXT_MCU_ADC	Reserved external voltage detection pin
RFU8	EXT_LCD_CS/RW	LCD CS signal
RFU9	EXT_MCU_TXD	Reserved serial port output signal
RFU10	MS_ID	Dual card backup identifier signal
RFU11	MS_DATA	Dual card backup connection signal
RFU12	EXT_LCD_BL1	LCD backlight signal 2

Specifications

Maximum Resolution	512x384@60Hz	
Electrical Specifications	Input voltage	DC 3.3 V to 5.5 V
	Rated current	0.5 A
	Rated power consumption	2.5 W
Operating Environment	Temperature	-20°C to +70°C
	Humidity	10% RH to 90% RH, non-condensing
Storage	Temperature	-25°C to +125°C

Environment	Humidity	0% RH to 95% RH, non-condensing
Physical Specifications	Dimensions	67.6 mm × 35.0 mm × 5.2 mm
	Net weight	7.2 g Note: It is the weight of a single receiving card only.
	Gross weight	840.0 g Note: It is the total weight of the product, printed materials and packing materials packed according to the packing specifications.
Packing Information	Packing specifications	An antistatic bag and anti-collision foam are provided for each receiving card. Each packing box contains 40 receiving cards.
	Packing box dimensions	378.0 mm × 190.0 mm × 120.0 mm

The amount of current and power consumption may vary depending on various factors such as product settings, usage, and environment.

Copyright © 2022 Xi'an NovaStar Tech Co., Ltd. All Rights Reserved.

No part of this document may be copied, reproduced, extracted or transmitted in any form or by any means without the prior written consent of Xi'an NovaStar Tech Co., Ltd.

Trademark

NOVA STAR is a trademark of Xi'an NovaStar Tech Co., Ltd.

Statement

Thank you for choosing NovaStar's product. This document is intended to help you understand and use the product. For accuracy and reliability, NovaStar may make improvements and/or changes to this document at any time and without notice. If you experience any problems in use or have any suggestions, please contact us via the contact information given in this document. We will do our best to solve any issues, as well as evaluate and implement any suggestions.

Official website
www.novastar.tech

Technical support
support@novastar.tech