



■ Features :

- Universal AC input / Full range
- Built-in active PFC function
- High efficiency up to 86%
- Protections: Short circuit / Overload / Over voltage / Over temperature
- Cooling by free air convection
- 1U low profile 36mm
- Conformal coated
- ZVS technology to reduce power dissipation
- LED indicator for power on
- 3 years warranty



SPECIFICATION

MODEL		HDP-190	
OUTPUT	OUTPUT NUMBER	V1	V2
	DC VOLTAGE	+3.8V	+2.8V
	RATED CURRENT	33A	20A
	CURRENT RANGE (max.)	0 ~ 40A	0 ~ 22A
	RATED POWER	181.4W (typ.)	192W (max.)
	OUTPUT POWER (max.)	192W continue. V1 total power output shall not exceed 160W (max. 40A) ; V2 total power output shall not exceed 66W (max. 22A) (The V1 & V2 combine total power output shall not exceed 192W)	
	RIPPLE & NOISE (max.) Note.2	100mVp-p	100mVp-p
	VOLTAGE ADJ. RANGE Note.6	3.6 ~ 4V	2.5 ~ 3V
	VOLTAGE TOLERANCE Note.3	±2.0%	±2.0%
	LINE REGULATION	±0.5%	±0.5%
	LOAD REGULATION	±2.0%	±2.0%
	SETUP, RISE TIME	1000ms, 50ms/230VAC 2500ms, 50ms/115VAC at full load	
	HOLD UP TIME (Typ.)	16ms/230VAC 16ms/115VAC at full load	
INPUT	VOLTAGE RANGE Note.5	90 ~ 264VAC	127 ~ 370VDC
	FREQUENCY RANGE	47 ~ 63Hz	
	POWER FACTOR (Typ.)	PF≥0.94/230VAC	PF≥0.98/115VAC at full load
	EFFICIENCY (Typ.)	86%	
	AC CURRENT (Typ.)	2.7A/115VAC	1.1A/230VAC
	INRUSH CURRENT (Typ.)	30A/115VAC	45A/230VAC
	LEAKAGE CURRENT	<0.7mA / 240VAC	
PROTECTION	OVERLOAD	V1+V2: 105 ~ 150% max. output power ; or V2: 125 ~ 170% rated current Protection type: Hiccup mode, recovers automatically after fault condition is removed	
	OVER VOLTAGE	V1: 4.37 ~ 5.13V	V2: 3.22 ~ 3.78V
	OVER TEMPERATURE	Protection type : Shut down o/p voltage, re-power on to recover Shut down o/p voltage, re-power on to recovery	
ENVIRONMENT	WORKING TEMP.	-30 ~ +70°C (Refer to "Derating Curve")	
	WORKING HUMIDITY	20 ~ 90% RH non-condensing	
	STORAGE TEMP., HUMIDITY	-40 ~ +85°C, 10 ~ 95% RH	
	TEMP. COEFFICIENT	±0.03%/°C (0 ~ 50°C)	
	VIBRATION	10 ~ 500Hz, 2G 10min./1cycle, 60min. each along X, Y, Z axes	
SAFETY & EMC (Note 4)	SAFETY STANDARDS	UL60950-1, TUV EN60950-1, CCC GB4943.1 approved	
	WITHSTAND VOLTAGE	I/P-O/P:3KVAC I/P-FG:2KVAC O/P-FG:0.5KVAC	
	ISOLATION RESISTANCE	I/P-O/P, I/P-FG, O/P-FG:100M Ohms / 500VDC / 25°C/ 70% RH	
	EMC EMISSION	Compliance to EN55022 (CISPR22), GB9254, class B, EN61000-3-2,-3, GB17625.1	
	EMC IMMUNITY	Compliance to EN61000-4-2,3,4,5,6,8,11, EN55024, EN61000-6-2, heavy industry level, criteria A	
OTHERS	MTBF	111.3K hrs min. MIL-HDBK-217F (25°C)	
	DIMENSION	215*115*36mm (L*W*H)	
	PACKING	0.95Kg; 15pcs/15.3Kg/0.7CUFT	
NOTE	<ol style="list-style-type: none"> 1. All parameters NOT specially mentioned are measured at 230VAC input, rated load and 25°C of ambient temperature. 2. Ripple & noise are measured at 20MHz of bandwidth by using a 12" twisted pair-wire terminated with a 0.1uf & 47uf parallel capacitor. 3. Tolerance : includes set up tolerance, line regulation and load regulation. 4. The power supply is considered a component which will be installed into a final equipment. The final equipment must be re-confirmed that it still meets EMC directives. 5. Derating may be needed under low input voltages. Please check the derating curve for more details. 6. Output voltage between V1 and V2 should be higher than 1.0V(V1-V2≥1.0V). 		

Mechanical Specification

Case No.206A Unit:mm

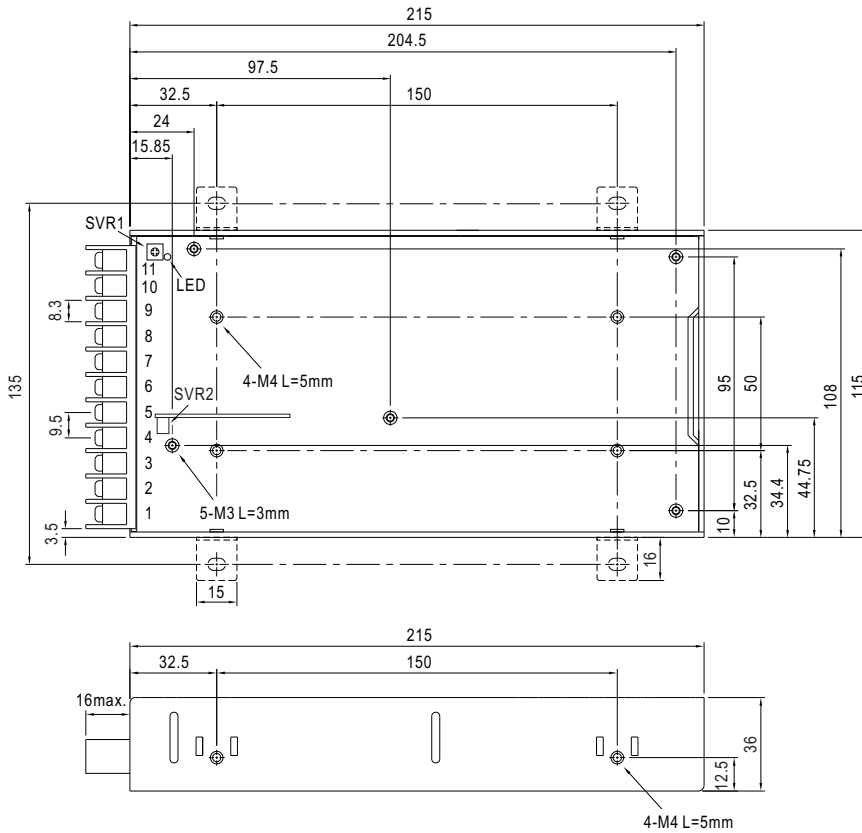

Terminal Pin No. Assignment :

Pin No.	Assignment	Pin No.	Assignment
1	AC/L	4,5	V2(+2.8V)
2	AC/N	6,7	V1(+3.8V)
3	FG	8,9,10,11	COM

SVR1: V1(+3.8V)ADJ.
SVR2: V2(+2.8V)ADJ.

Block Diagram

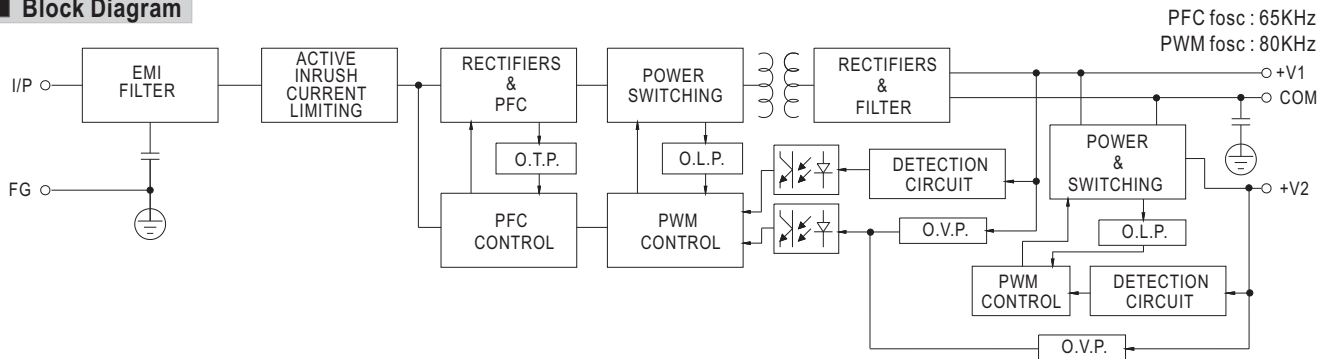

Derating Curve

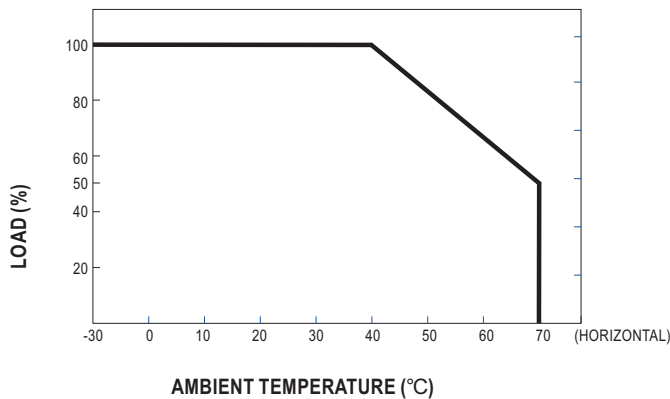

Output Derating VS Input Voltage

