

# AT32

## Receiving Card

V1.0.1



Specifications

## Change History

Document Version	Firmware Version	Release Date	Description
V1.0.1	V4.6.2.0	2020-04-09	<ul style="list-style-type: none"> <li>Updated the firmware version.</li> <li>Updated the indicator description.</li> </ul>
V1.0.0	V4.6.1.0	2020-01-02	First release

## Introduction

The AT32 is a general small receiving card developed by NovaStar. A single AT32 loads up to 512×256 pixels. With various highlights such as pixel level brightness and chroma calibration, individual Gamma adjustment for RGB and 3D function, the AT32 can greatly improve the display effect and user experience.

The AT32 uses high-density connectors for communication to limit effects of dust and vibration, resulting in high stability and reliability. It supports up to 32 groups of parallel RGB data or 64 groups of serial data (extendable to 128 groups of serial data). Its reserved pins allow for custom functions of users. Thanks to its EMC Class B compliant hardware design, the AT32 has improved electromagnetic compatibility and is suitable to many applications.

## Features

### Improvements to Display Effect

- Pixel level brightness and chroma calibration  
Working with NovaLCT and NovaCLB, the receiving card supports brightness and chroma calibration on each LED, which can effectively remove color discrepancies and greatly improve LED display brightness and chroma consistency, allowing for better image quality.
- Quick seam correction  
Working with NovaLCT, the receiving card supports quick adjustment of bright or dark lines caused by splicing of cabinets and modules. This function is easy to use and the adjustment takes effect immediately.  
In NovaLCT (V5.2.0 or later), seam correction can be performed without using or changing the video source.
- 3D function  
When the receiving card works with the independent controller which supports 3D function, users can enable the 3D function in NovaLCT or on operation panel of the controller, and set 3D parameters to allow for 3D display effects.
- Individual Gamma adjustment for RGB  
Working with NovaLCT (V5.2.0 or later) and the independent controller which supports this function, the receiving card supports individual adjustment of red Gamma, green Gamma and blue Gamma, which can effectively control image non-uniformity under low grayscale and white balance offset, allowing for a more realistic image.

- Image rotation in 90° increments  
In NovaLCT, the display image can be set to rotate in multiples of 90° (0°, 90°, 180° and 270°).

### Improvements to Maintainability

- Smart module (supported by dedicated firmware)  
The smart module is composed of Flash and MCU.  
Flash can store calibration coefficients and module parameters. MCU can communicate with the receiving card to monitor temperature, voltage and ribbon cable communication status at the module level. Working with the driver chip, MCU also supports LED error detection.  
The smart module allows for a smaller monitoring unit, requiring no independent monitoring card and saving cabinet space.
- Automatic module calibration  
After the module (with module Flash) has been replaced and power is supplied, the receiving card can automatically read the new module ID and calibration coefficients, and save them to the receiving card.
- Module Flash management  
Module Flash information can be managed in NovaLCT. The module ID can be managed, and calibration coefficients and module parameters can be stored in the module Flash.
- One-click application of calibration coefficients saved in module Flash  
In the event of network outage, users can hold down the self-test button to read the calibration

coefficients in module Flash back to the receiving card.

- Mapping function  
After the Mapping function is enabled in NovaLCT, each of the target cabinets will display the receiving card number and Ethernet port information, allowing users to easily obtain the location and wiring route of receiving cards.
- Setting of pre-stored image on receiving card  
In NovaLCT, a specified image can be set as the LED screen startup image or as the image to be displayed on LED screen when the Ethernet cable is disconnected or no video signal is available.
- Voltage and temperature monitoring  
The voltage and temperature of the receiving card can be monitored without using peripherals. The monitoring data can be checked in NovaLCT.
- Cabinet LCD  
The receiving card supports the LCD connected to the cabinet. The LCD can display temperature, voltage, single operating time and total operating time of the receiving card.
- Bit error rate monitoring  
The receiving card can work with NovaLCT (V5.2.0 or later) to monitor the network communication quality between the sending device and receiving card, or between receiving cards, and record the number of erroneous packets to help troubleshoot network communication problems.
- Readback of firmware program

In NovaLCT (V5.2.0 or later), the receiving card firmware program can be read back and saved to local computer.

- Readback of configuration parameters  
In NovaLCT, the receiving card configuration parameters can be read back and saved to local computer.

### Improvements to Reliability

- Dual-card backup and status monitoring  
In an environment with requirements for high reliability, two receiving cards can be mounted onto a single HUB board. In the case that main receiving card fails, the backup card will serve to ensure uninterrupted operation of the display. The working status of main and backup receiving cards can be monitored in NovaLCT (V5.2.0 or later).
- Status monitoring of dual power supplies  
The receiving card supports dual power supplies and can detect whether their working statuses are normal.
- Loop backup  
The receiving card can improve the reliability for cascading of receiving cards through main and backup redundant mechanism. If either main or backup cascading lines fail, the other will begin to work to ensure uninterrupted operation of the display.
- Dual backup of program  
Two copies of application programs are saved in the receiving card at the factory to avoid the problem that the receiving card may get stuck due to program update exception.

## Appearance



Power Indicator Running Indicator



High-Density Connector

All product pictures shown in this document are for illustration purpose only. Actual product may vary.

## Indicators

Indicator	Color	Status	Description
Running indicator	Green	Flashing once every other 1s	Receiving card is functioning normally. Ethernet cable connection is normal, and video source input is available.
		Flashing once every other 3s	Ethernet cable connection is abnormal.
		Flashing 3 times every other 1s	Ethernet cable connection is normal, but no video source input is available.
		Flashing every other 0.2s	Receiving card failed to load the program in the application area and now is using the backup program.
		Flashing 8 times every other 1s	A redundancy switchover occurred on the Ethernet port and the loop backup has taken effect.
Power indicator	Red	Always on	The power input is normal.

## Dimensions

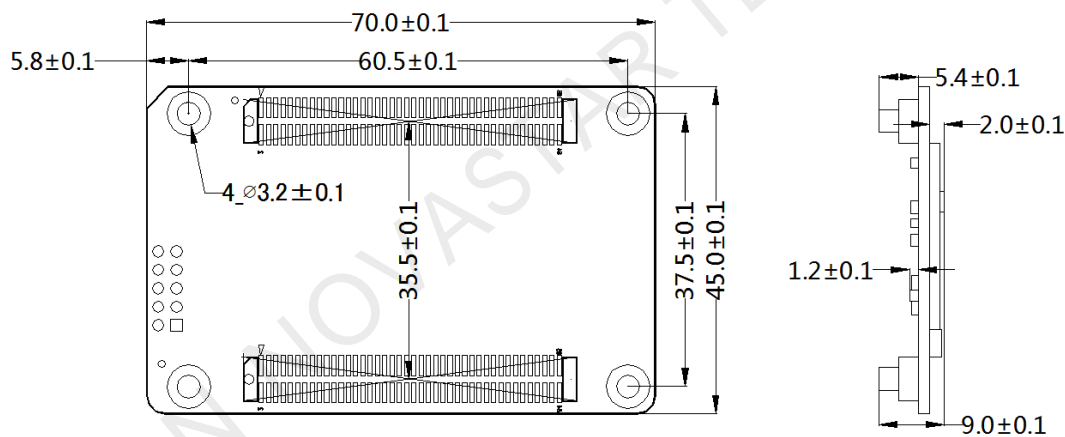

Unit: mm

### Note:

The distance between outer surfaces of AT32 and HUB boards after their high-density connectors fit together is 8.0 mm. An 8-mm copper pillar is recommended.

# Pins

## 32 Groups of Parallel RGB Data

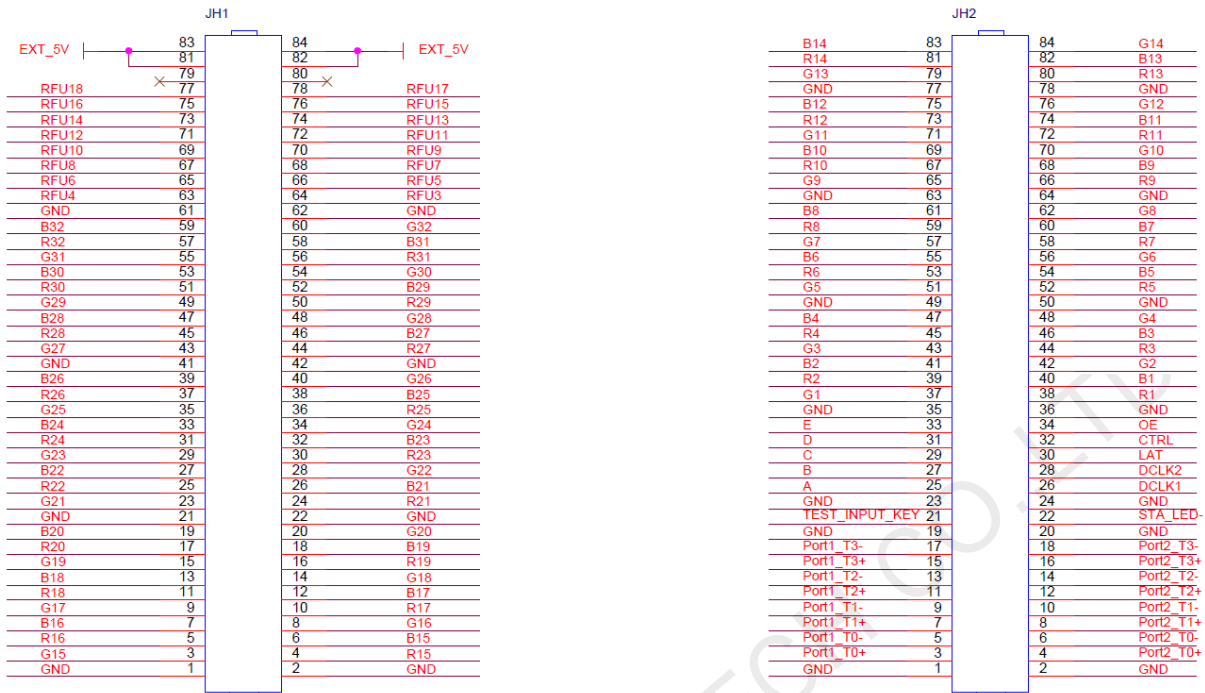

JH1						JH2					
5V	EXT_5 V	83	84	EXT_5 V	5V	/	B14	83	84	G14	/
	EXT_5 V	81	82	EXT_5 V		/	R14	81	82	B13	/
/	NC	79	80	NC	/	/	G13	79	80	R13	/
Reserv ed pin	RFU18	77	78	RFU17	Reserv ed pin	Ground	GND	77	78	GND	Ground
	RFU16	75	76	RFU15		/	B12	75	76	G12	/
	RFU14	73	74	RFU13		/	R12	73	74	B11	/
	RFU12	71	72	RFU11		/	G11	71	72	R11	/
	RFU10	69	70	RFU9		/	B10	69	70	G10	/
	RFU8	67	68	RFU7		/	R10	67	68	B9	/
RFU6	65	66	RFU5	/	G9	65	66	R9	/		
RFU4	63	64	RFU3	/	Ground	GND	63	64	GND	Ground	
Ground	GND	61	62	GND	Ground	/	B8	61	62	G8	/
/	B32	59	60	G32	/	/	R8	59	60	B7	/
/	R32	57	58	B31	/	/	G7	57	58	R7	/
/	G31	55	56	R31	/	/	B6	55	56	G6	/
/	B30	53	54	G30	/	/	R6	53	54	B5	/
/	R30	51	52	B29	/	/	G5	51	52	R5	/
/	G29	49	50	R29	/	Ground	GND	49	50	GND	Ground
/	B28	47	48	G28	/	/	B4	47	48	G4	/
/	R28	45	46	B27	/	/	R4	45	46	B3	/
/	G27	43	44	R27	/	/	G3	43	44	R3	/
Ground	GND	41	42	GND	Ground	/	B2	41	42	G2	/
/	B26	39	40	G26	/	/	R2	39	40	B1	/
/	R26	37	38	B25	/	/	G1	37	38	R1	/
/	G25	35	36	R25	/	Ground	GND	35	36	GND	Ground
/	B24	33	34	G24	/	Line decoding signal	E/DCLK2	33	34	OE	Display enable
/	R24	31	32	B23	/		D	31	32	NC	/
/	G23	29	30	R23	/		C	29	30	LAT	Latch signal output
/	B22	27	28	G22	/		B	27	28	NC	/
/	R22	25	26	B21	/		A	25	26	DCLK1	Shift clock

JH1					JH2						
/	G21	23	24	R21	/	Ground	GND	23	24	GND	output
Ground	GND	21	22	GND	Ground	Test button	TEST_INP UT_KEY	21	22	STA_LED-	Status indicator
/	B20	19	20	G20	/	Ground	GND	19	20	GND	Ground
/	R20	17	18	B19	/	Gigabit Ethernet port	Port1_T3-	17	18	Port2_T3-	Gigabit Ethernet port
/	G19	15	16	R19	/		Port1_T3+	15	16	Port2_T3+	
/	B18	13	14	G18	/		Port1_T2-	13	14	Port2_T2-	
/	R18	11	12	B17	/		Port1_T2+	11	12	Port2_T2+	
/	G17	9	10	R17	/		Port1_T1-	9	10	Port2_T1-	
/	B16	7	8	G16	/		Port1_T1+	7	8	Port2_T1+	
/	R16	5	6	B15	/		Port1_T0-	5	6	Port2_T0-	
/	G15	3	4	R15	/	Port1_T0+	3	4	Port2_T0+		
Ground	GND	1	2	GND	Ground	Ground	GND	1	2	GND	Ground

64 Groups of Serial Data

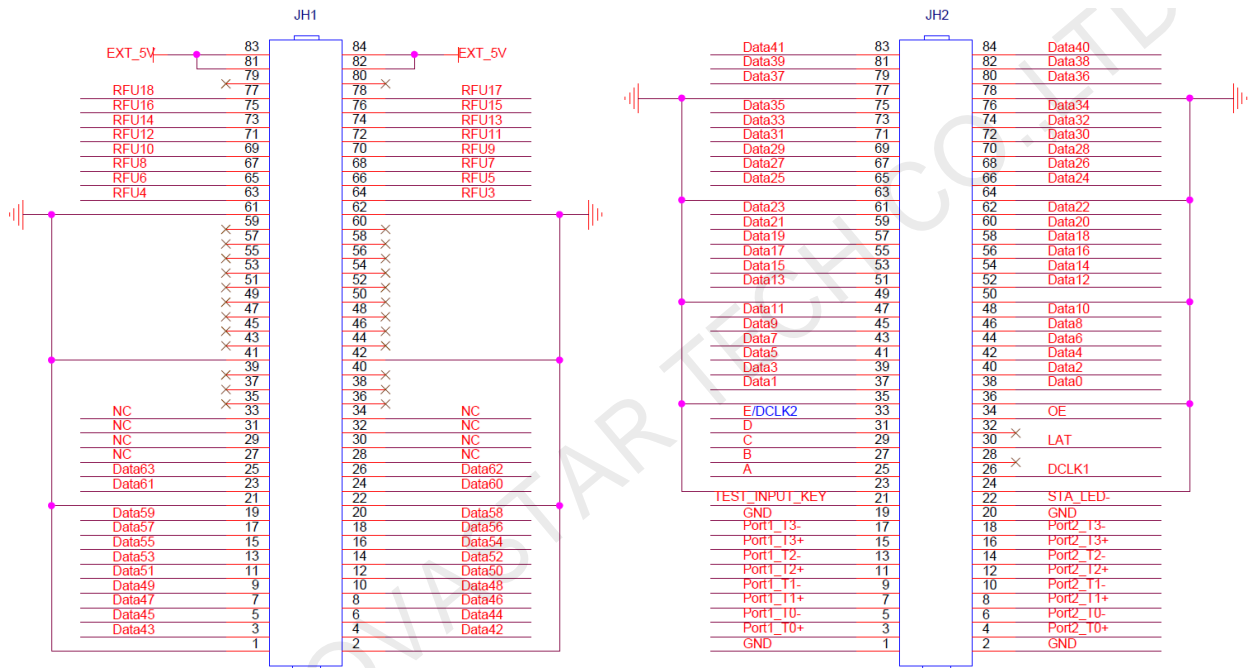

JH1					JH2						
5V	EXT_5 V	83	84	EXT_5 V	5V	/	Data41	83	84	Data	/
	EXT_5 V	81	82	EXT_5 V		/	Data39	81	82	Data	/
/	NC	79	80	NC	/	/	Data37	79	80	Data	/
Reserv ed pin	RFU18	77	78	RFU17	Reserve d pin	/	GND	77	78	GND	Ground
	RFU16	75	76	RFU15		/	Data35	75	76	Data34	/
	RFU14	73	74	RFU13		/	Data33	73	74	Data32	/
	RFU12	71	72	RFU11		/	Data31	71	72	Data30	/
	RFU10	69	70	RFU9		/	Data29	69	70	Data28	/
	RFU8	67	68	RFU7		/	Data27	67	68	Data26	/
	RFU6	65	66	RFU5		/	Data25	65	66	Data24	/
Ground	GND	61	62	GND	Ground	Ground	GND	63	64	GND	Ground
/	NC	59	60	NC	/	/	Data23	61	62	Data22	/
/	NC	57	58	NC	/	/	Data21	59	60	Data20	/
/	NC	55	56	NC	/	/	Data19	57	58	Data18	/
/	NC	53	54	NC	/	/	Data17	55	56	Data16	/
/	NC	51	52	NC	/	/	Data15	53	54	Data14	/
/	NC	49	50	NC	/	Ground	GND	49	50	GND	Ground
/	NC	47	48	NC	/	/	Data11	47	48	Data10	/
/	NC	45	46	NC	/	/	Data9	45	46	Data8	/
/	NC	43	44	NC	/	/	Data7	43	44	Data6	/
Ground	GND	41	42	GND	Ground	/	Data5	41	42	Data4	/



JH1						JH2					
/	NC	39	40	NC	/	/	Data3	39	40	Data2	/
/	NC	37	38	NC	/	/	Data1	37	38	Data0	/
/	NC	35	36	NC	/	Ground	GND	35	36	GND	Ground
/	NC	33	34	NC	/	Line decodin g signal	E/DCLK2	33	34	OE	Display enable
/	NC	31	32	NC	/		D	31	32	NC	/
/	NC	29	30	NC	/		C	29	30	LAT	Latch signal output
/	NC	27	28	NC	/		B	27	28	NC	/
/	Data63	25	26	Data62	/		A	25	26	DCLK1	Shift clock output
/	Data61	23	24	Data60	/	Ground	GND	23	24	GND	Ground
Ground	GND	21	22	GND	Ground	Test button	TEST_IN PUT_KEY	21	22	STA_LED-	Status indicato r
/	Data59	19	20	Data58	/	Ground	GND	19	20	GND	Ground
/	Data57	17	18	Data56	/	Gigabit Etherne t port	Port1_T3-	17	18	Port2_T3-	Gigabit Etherne t port
/	Data55	15	16	Data54	/		Port1_T3+	15	16	Port2_T3+	
/	Data53	13	14	Data52	/		Port1_T2-	13	14	Port2_T2-	
/	Data51	11	12	Data50	/		Port1_T2+	11	12	Port2_T2+	
/	Data49	9	10	Data48	/		Port1_T1-	9	10	Port2_T1-	
/	Data47	7	8	Data46	/		Port1_T1+	7	8	Port2_T1+	
/	Data45	5	6	Data44	/		Port1_T0-	5	6	Port2_T0-	
/	Data43	3	4	Data42	/		Port1_T0+	3	4	Port2_T0+	
Ground	GND	1	2	GND	Ground	Ground	GND	1	2	GND	Ground

## Reference Design for Extended Functions

Description of Pins for Extended Functions			
Pin	Recommended Module Flash Pin	Recommended Smart Module Pin	Reserved
RFU4	HUB_SPI_CLK	Reserved	Clock signal of serial pin
RFU6	HUB_SPI_CS	Reserved	CS signal of serial pin
RFU8	HUB_SPI_MOSI	/	Module Flash storage data input
	/	HUB_UART_TX	Smart module TX signal
RFU10	HUB_SPI_MISO	/	Module Flash storage data output
	/	HUB_UART_RX	Smart module RX signal
RFU3	HUB_CODE0		Module Flash BUS control pin
RFU5	HUB_CODE1		
RFU7	HUB_CODE2		
RFU9	HUB_CODE3		
RFU14	POWER_STA1		Dual power supply detection signal
RFU16	POWER_STA2		
RFU15	MS_DATA		Dual-card backup connection signal
RFU17	MS_ID		Dual-card backup identifier signal

### Note:

The RFU8 and RFU10 are signal multiplex extension pins. Only one pin from either the Recommended Smart Module Pin or the Recommended Module Flash Pin can be selected at the same time.

## Specifications

Maximum Loading Capacity	512×256 pixels	
Electrical Specifications	Input voltage	DC 3.3 V–5.5 V
	Rated current	0.6 A
	Rated power consumption	3.0 W

Operating Environment	Temperature	-20°C to +70°C
	Humidity	10% RH to 90% RH, non-condensing
Storage Environment	Temperature	-25°C to +125°C
	Humidity	0% RH to 95% RH, non-condensing
Physical Specifications	Dimensions	70.0 mm x 45.0 mm x 9.0 mm
	Net weight	16.5 g
Packing Information	Packing specifications	An antistatic bag and anti-collision foam are provided for each receiving card. Each packing box contains 40 receiving cards.
	Packing box dimensions	378.0 mm x 190.0 mm x 120.0 mm
Certifications	RoHS, EMC Class B	



**Copyright © 2020 Xi'an NovaStar Tech Co., Ltd. All Rights Reserved.**

No part of this document may be copied, reproduced, extracted or transmitted in any form or by any means without the prior written consent of Xi'an NovaStar Tech Co., Ltd.

**Trademark**

**NOVA STAR** is a trademark of Xi'an NovaStar Tech Co., Ltd.

**Statement**

You are welcome to use the product of Xi'an NovaStar Tech Co., Ltd. (hereinafter referred to as NovaStar). This document is intended to help you understand and use the product. For accuracy and reliability, NovaStar may make improvements and/or changes to this document at any time and without notice. If you experience any problems in use or have any suggestions, please contact us via contact info given in document. We will do our best to solve any issues, as well as evaluate and implement any suggestions.

[Official website](http://www.novastar.tech)  
[www.novastar.tech](http://www.novastar.tech)

[Technical support](mailto:support@novastar.tech)  
[support@novastar.tech](mailto:support@novastar.tech)