



LED ECO 5M STRIP KITS

Distributed by:

Reduction Revolution Pty Ltd

www.reductionrevolution.com.au/LED

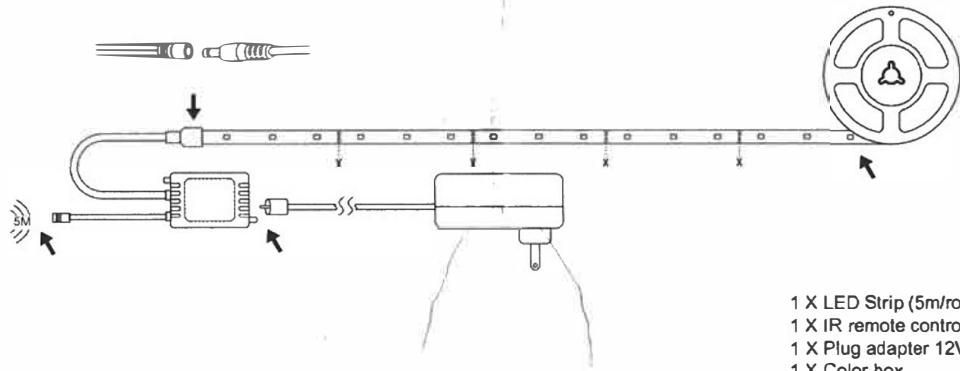

- 1 X LED Strip (5m/roll)
- 1 X IR remote controller
- 1 X Plug adapter 12V
- 1 X Color box
- 1 X User instruction

LED ECO 5M STRIP KITS	W	K	V	IP	Ta(°C)	Product weight
LDVSTRIP5M830	24	3000	12V plug adapter	20	0°C to + 40°C	210g
LDVSTRIP5M840	24	4000	12V plug adapter	20	0°C to + 40°C	210g
LDVSTRIP5M865	24	6500	12V plug adapter	20	0°C to + 40°C	210g

LED ECO 5M STRIP KIT

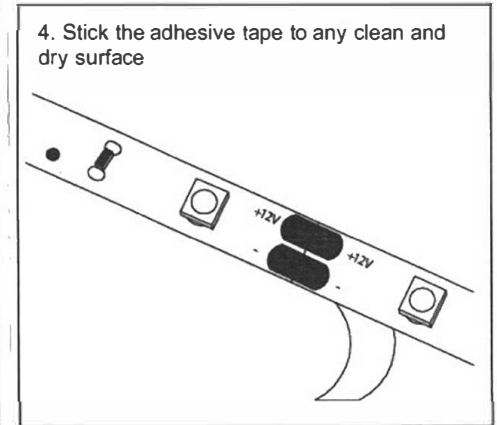
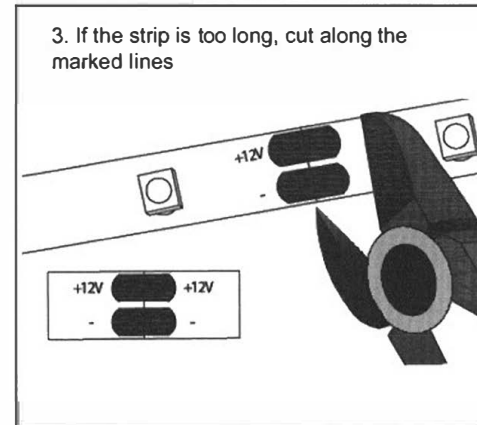
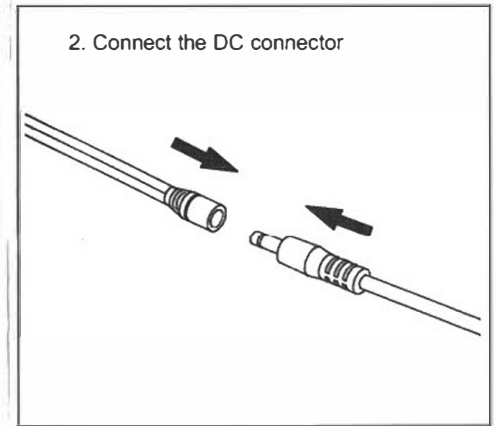
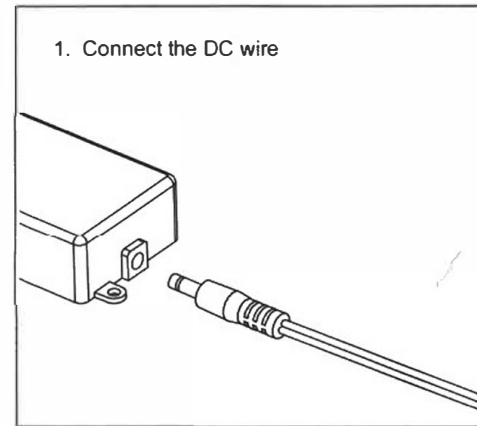
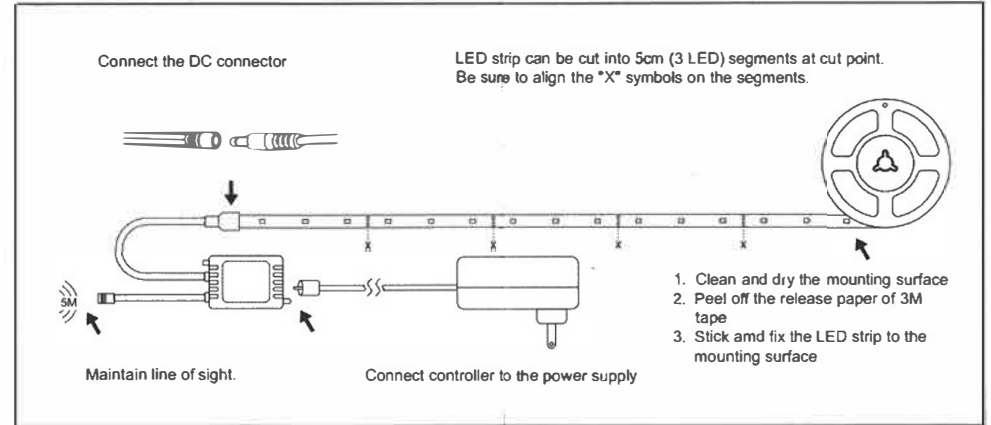

LED ECO 5M STRIP KITS

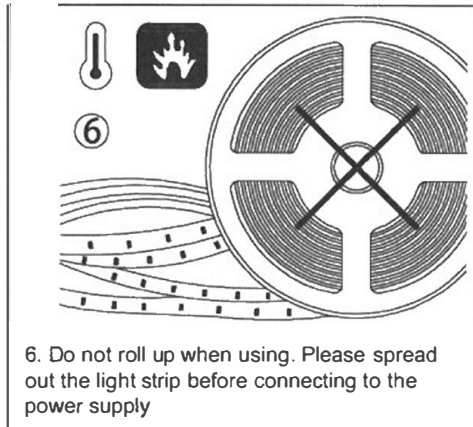
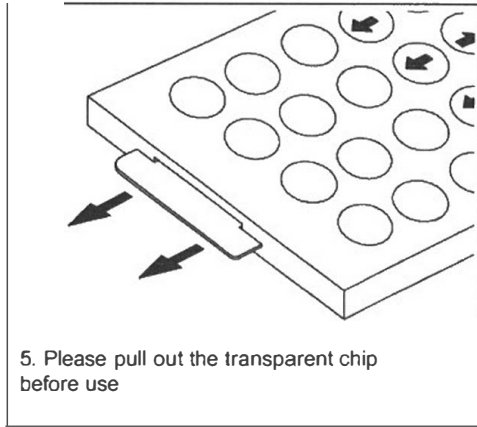

LED ECO 5M STRIP KITS

WARNINGS:

- This lighting chain must not be used without all parts being in place.
- Maximum length in connection should be no more than 5 meters.
- Do not turn on the power when installation and dismantling.
- Do not turn on the power when strip is in packaging or when it's not fully spread.
- Do not cover the strip with any heat insulating or inflammable material during installation and application.
- The strip shall be disposed in case there is any breakage.
- The strip is suitable for indoor application only, avoid wet areas.
- Do not clean the strip with solvent that contains aromatic hydrocarbons or chlorinated hydrocarbon.
- Do not connect the chain to the supply while it is in the packing.
- The chips are not replaceable.

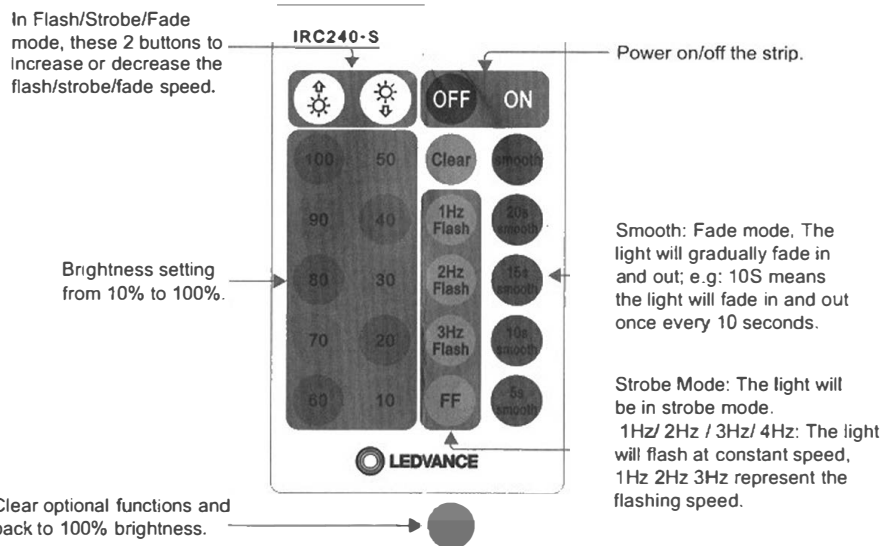

Luminaires not suitable for covering with thermally insulating material.

Distributed by:

Reduction Revolution Pty Ltd

www.reductionrevolution.com.au/LED

WARRANTY AGAINST DEFECTS:

Your LED ECO 5M STRIP KIT from LEDVANCE comes with a product warranty of 3 years for quality assurance, the terms and conditions of which are set out in this document. The Warranty applies exclusively to LED Light Fittings from LEDVANCE purchased within Australia and New Zealand for normal domestic or commercial use.

The Warranty is offered to you by:

LEDVANCE Pty Ltd
 Suite 2.1A, 394 Lane Cove Road
 Macquarie Park NSW 2113
 Phone contact: 1300 467 726 or +61 2 9481 780
 Email address: technical.au@ledvance.com

IMPORTANT: Our goods come with guarantees that cannot be excluded under the Australian Consumer Law. You are entitled to a replacement or refund for a major failure and compensation for any other reasonably foreseeable loss or damage. You are also entitled to have the goods repaired or replaced if the goods fail to be of acceptable quality and the failure does not amount to a major failure.