



**TOMMY
DOCKS®**

Tommy Docks

4003 Dixie Ave, Wausau, WI 54401

Phone : 715-842-3804

Toll Free : 866-675-1880

Fax : 715-842-3420

Winch Leveling

Assembly Instructions

Model # TD-10072

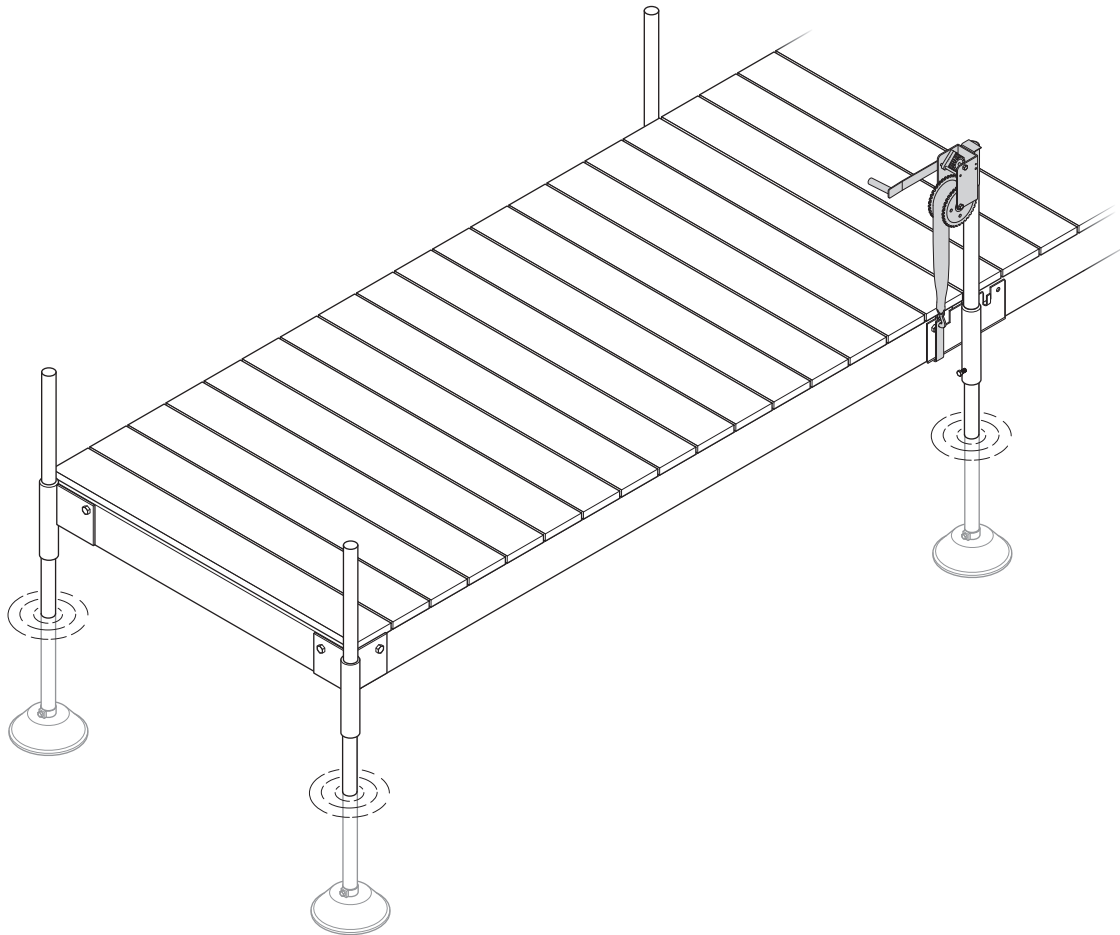

Thank you for choosing our Tommy Dock Interlocking system. The following instructions assume you have chosen your Tommy Dock layout and examined the bill of materials. The bill of materials describes all necessary hardware, post (refer to post length formula), and optional accessories to assemble and install your Tommy Dock system. Ask your dealer for answers to any questions you may have.

Caution: Use only cordless power tools when near or on water.

www.tommydocks.com

Winch Leveling Components

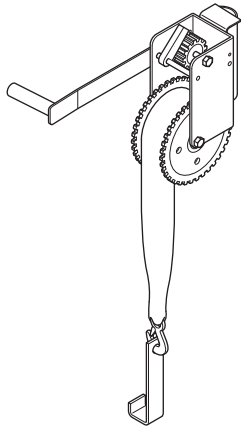

Winch Lock
Leveler

Tools

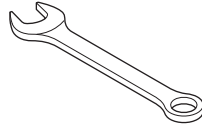

1/2" Box
End Wrench

1 Winch Leveling Setup. Attach Strap to Winch Assembly following the instructions provided by the Winch manufacturer. Attach the 1/2" x 3" Bolt and 1/2" Nylon Insert Hex Nut to the Upper Winch Tube. Attach the Strap Hook to the Leveling Hook.

2 Leveling Operation. Place Winch Leveling Assembly onto the Pipe Leg.

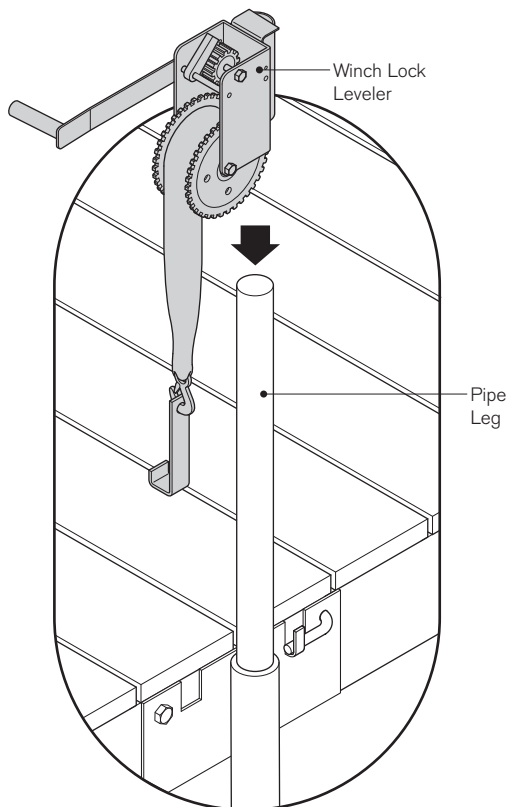

3 Unwind the Winch Strap and place the Leveling Hook under the Dock Bracket.

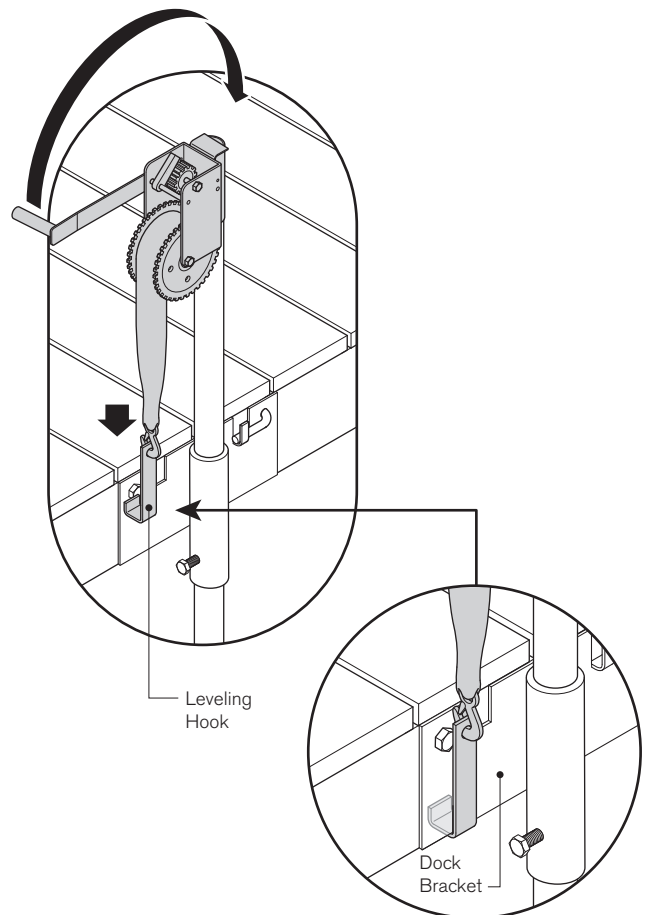

- 4** Wind the Winch until the Winch Stap becomes taut (4a). Loosen the single 1/2" Dock Bracket Adjusting Bolt adjacent to the Leveling Hook (4b).

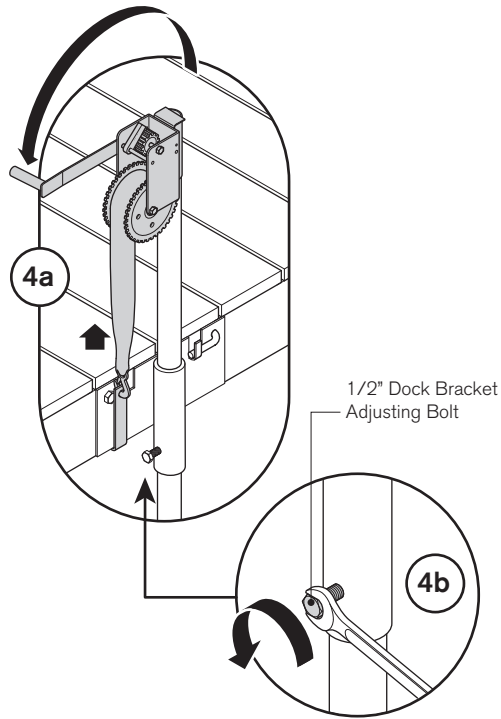

- 5** Lift or lower the Dock to achieve a level position.

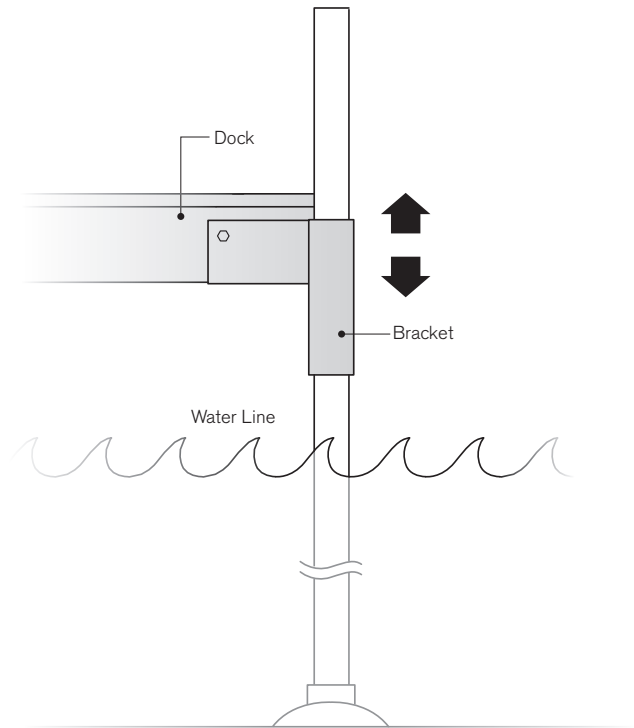

- 6** Tighten the 1/2" Dock Adjusting Bolt. Remove the Winch Leveling Assembly and repeat the procedure on the next Pipe Leg.

Note: Depending upon the amount of adjustment that is required to level the Dock Section, it may be necessary to repeat the previous leveling steps several times.

