



**TOMMY
DOCKS®**

Tommy Docks

4003 Dixie Ave, Wausau, WI 54401

Phone : 715-842-3804

Toll Free : 866-675-1880

Fax : 715-842-3420

4' Cedar Bench

Assembly Instructions

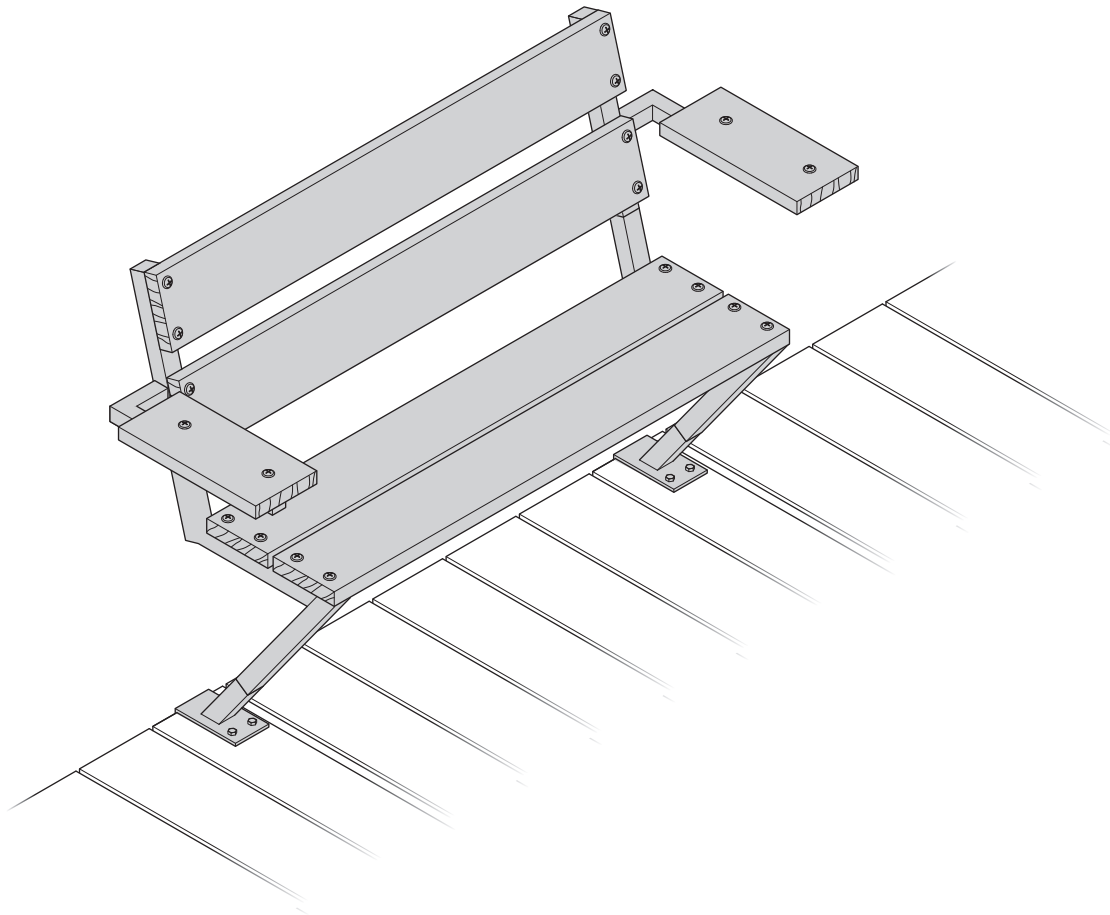

4' Cedar Bench Components

$\frac{5}{4}$ x 6" x 48"
Deck Board
Qty 4

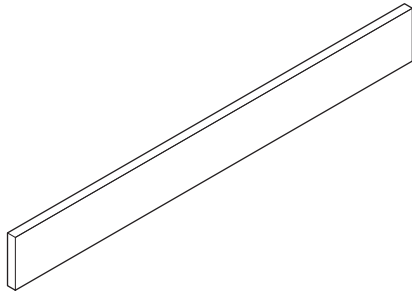

$\frac{5}{4}$ x 6" x 16"
Deck Board
Qty 2

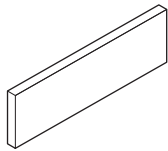

Mount Assembly
Qty 2

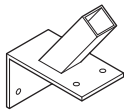

Seat Assembly
Qty 2

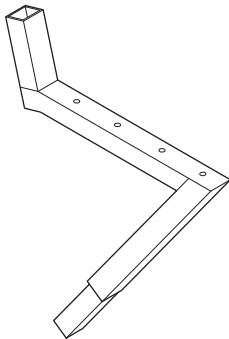

Backrest Assembly
Qty 2

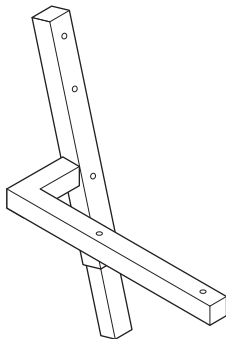

Hardware

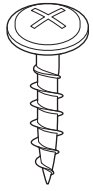

$\frac{5}{16}$ " x 1 $\frac{1}{4}$ "
Truss Head Screws
Qty 20

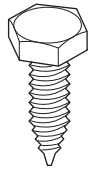

$\frac{5}{16}$ " x 1 $\frac{1}{4}$ "
Hex Head Lag Screws
Qty 8

Tools

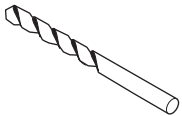

$\frac{7}{32}$ " Drill Bit
Qty 1

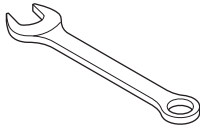

$\frac{5}{16}$ " Wrench
Qty 1

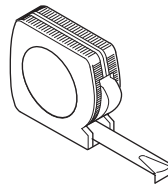

Tape Measure



Drill

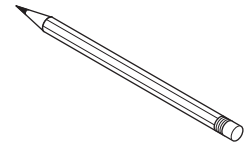

Pencil

1

Lower the Seat Rear Board and the Seat Front Board onto Seat Assembly. The Seat Rear Board has holes spaced 4" apart (1a) and the Seat Front Board has holes 2" apart (1b). Secure boards to Seat Assembly using four (4) Truss Head Screws per board (1c).

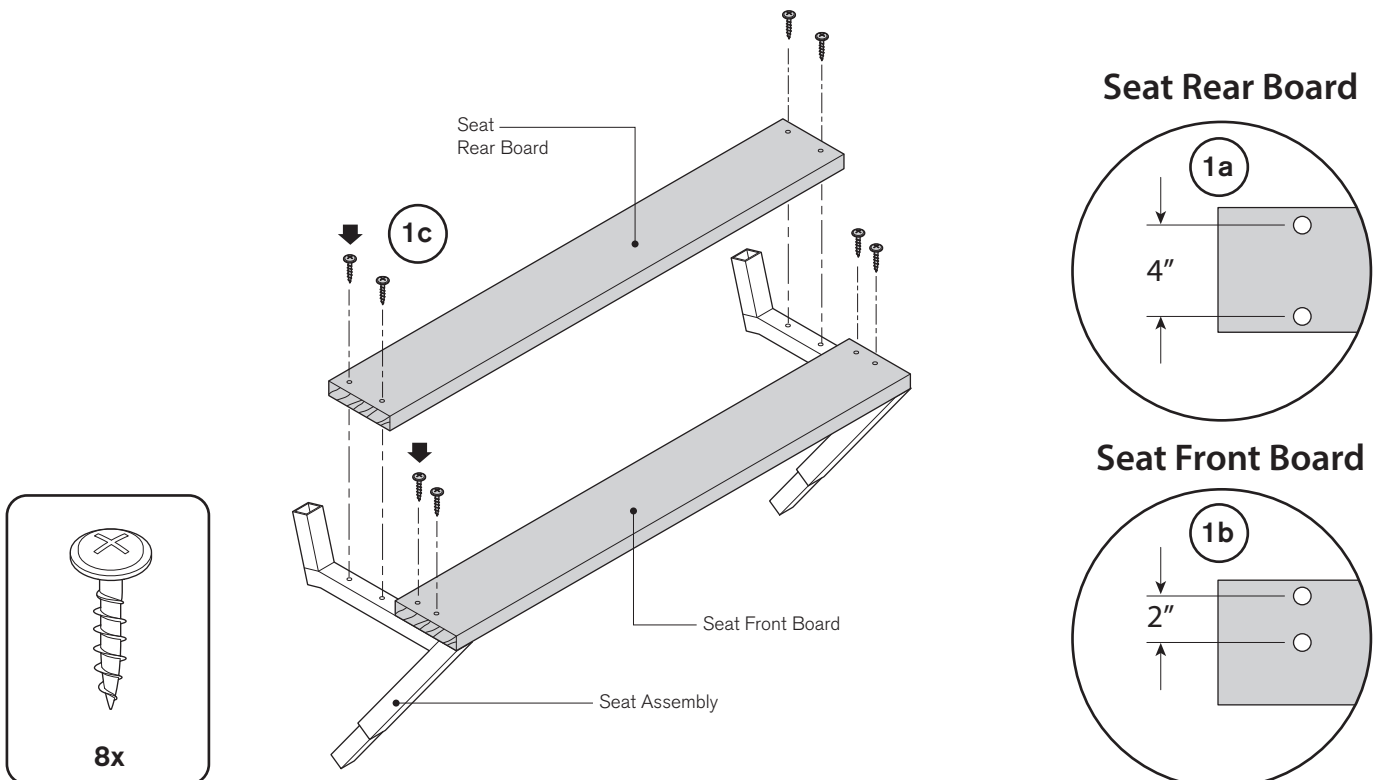

- 2** Place Back Top Boards onto Backrest Assembly. The Back Top Boards have holes spaced 3" apart (2a). Secure boards to Back Top Boards to Backrest Assembly using four (4) Truss Head Screws per board (2b).

Back Top Board

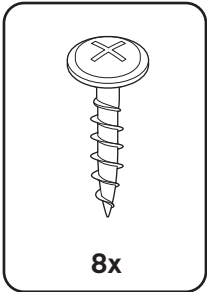
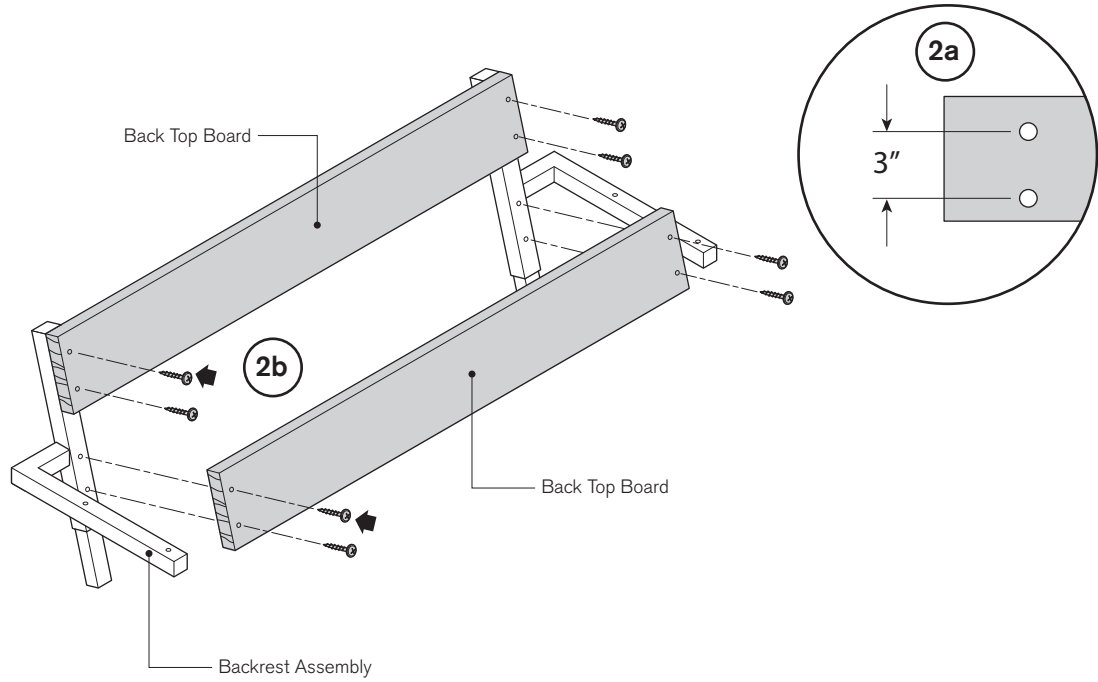

- 3** Lower Armboards onto Backrest Assembly and secure each Arm Board using two (2) Truss Head Screws per board.

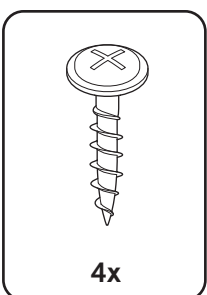
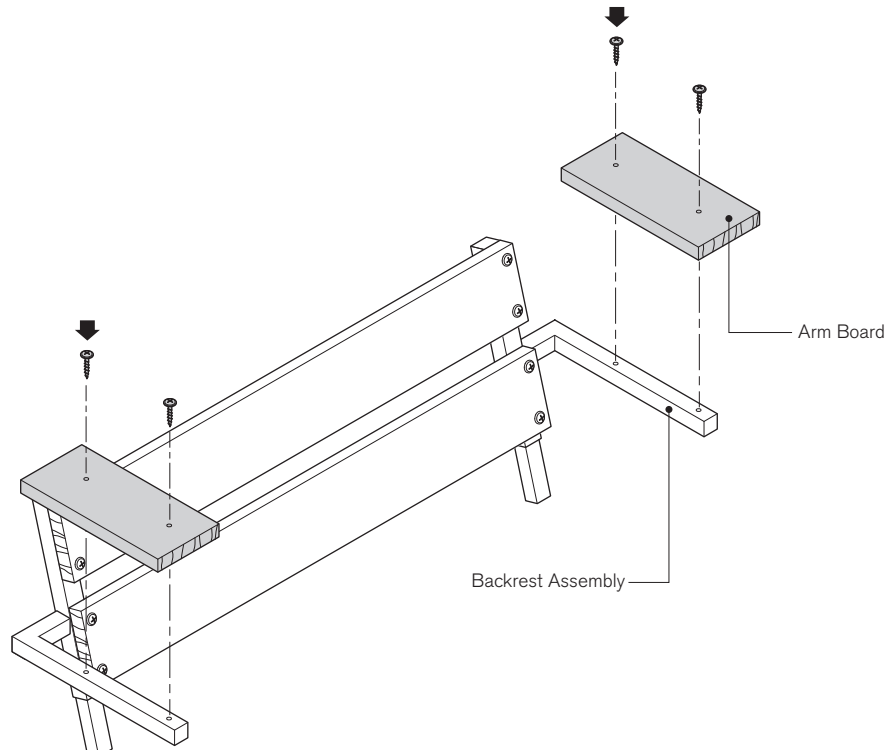

4

Place Back Assembly into Seat Assembly by inserting the Mount Assembly Dowel Shaft into the Seat Assembly Leg.

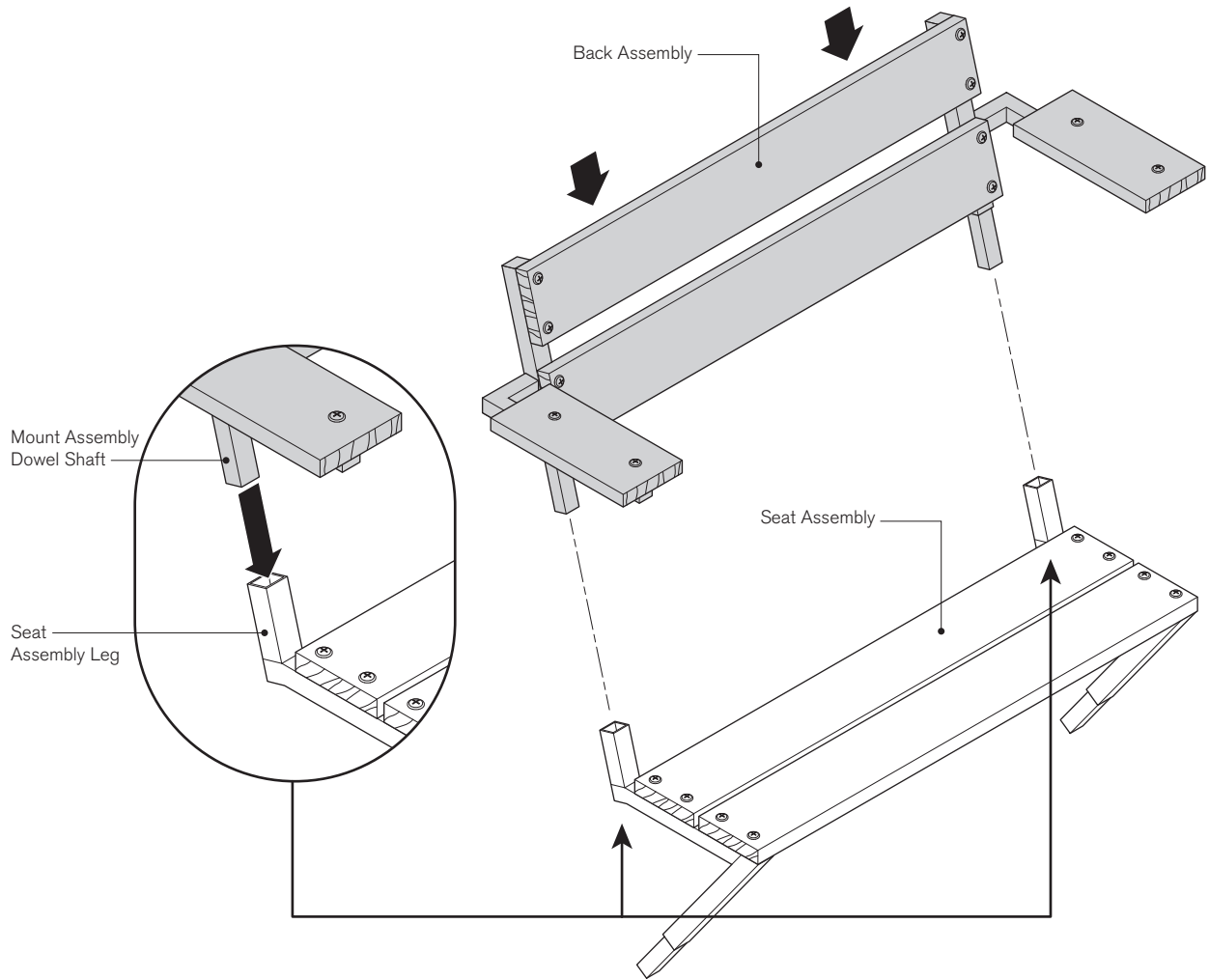

- 5** Clamp each Mount Assembly to deck (5a). Space both Mount Assemblies so they are XX" apart on center and mark with pencil (5b).

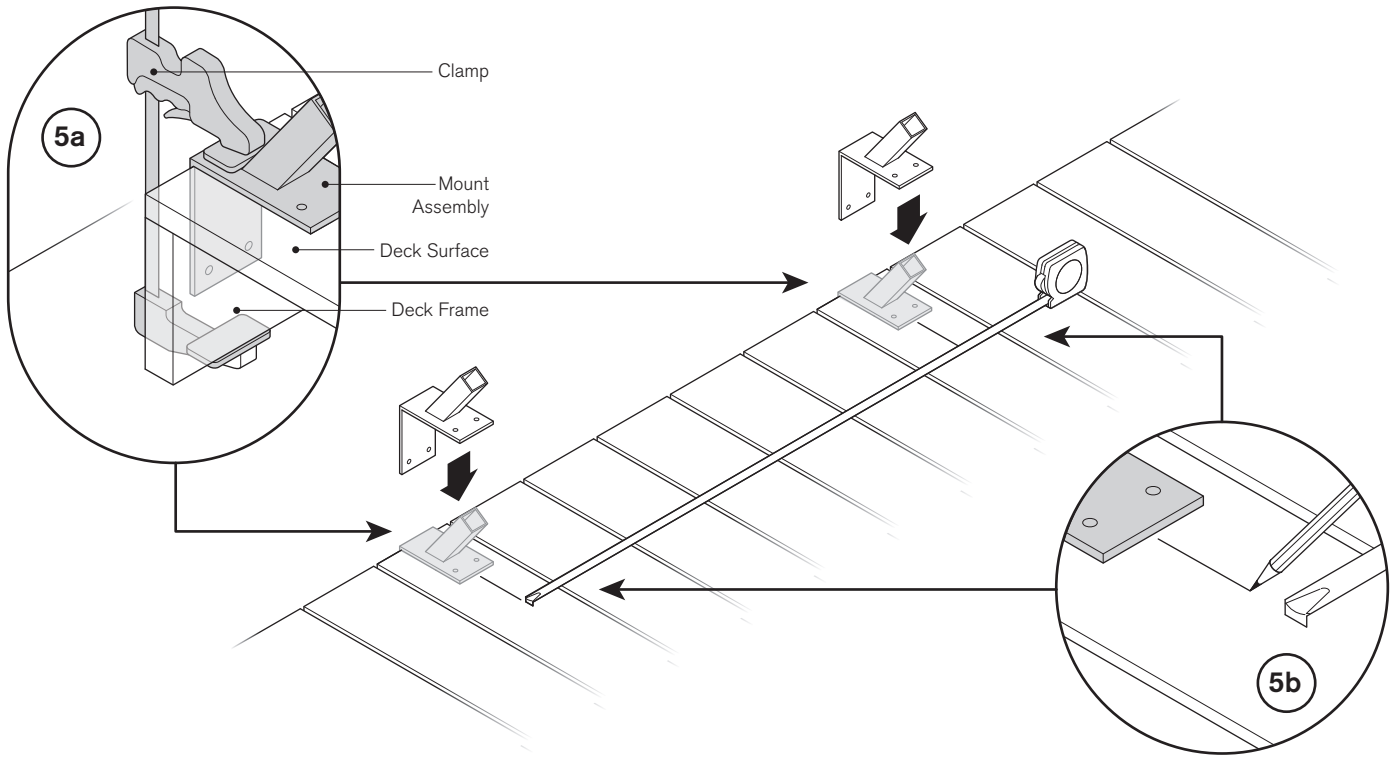

- 6** Using the holes in the Mount Assemblies as a template, drill a 7/32" pilot holes into the deck at each corresponding hole location (6a and 6b).

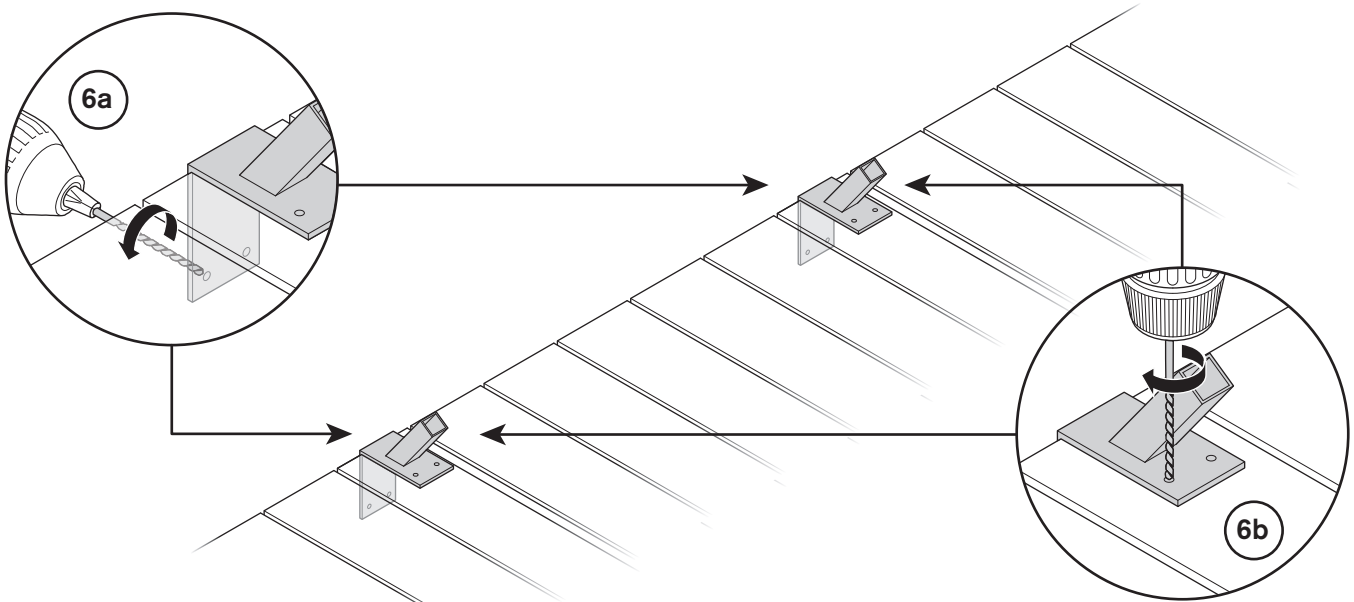

- 7** Secure each Mount Assembly to the dock at each corresponding hole location using four (4) Lag Bolts per Mount Assembly (7a and 7b).

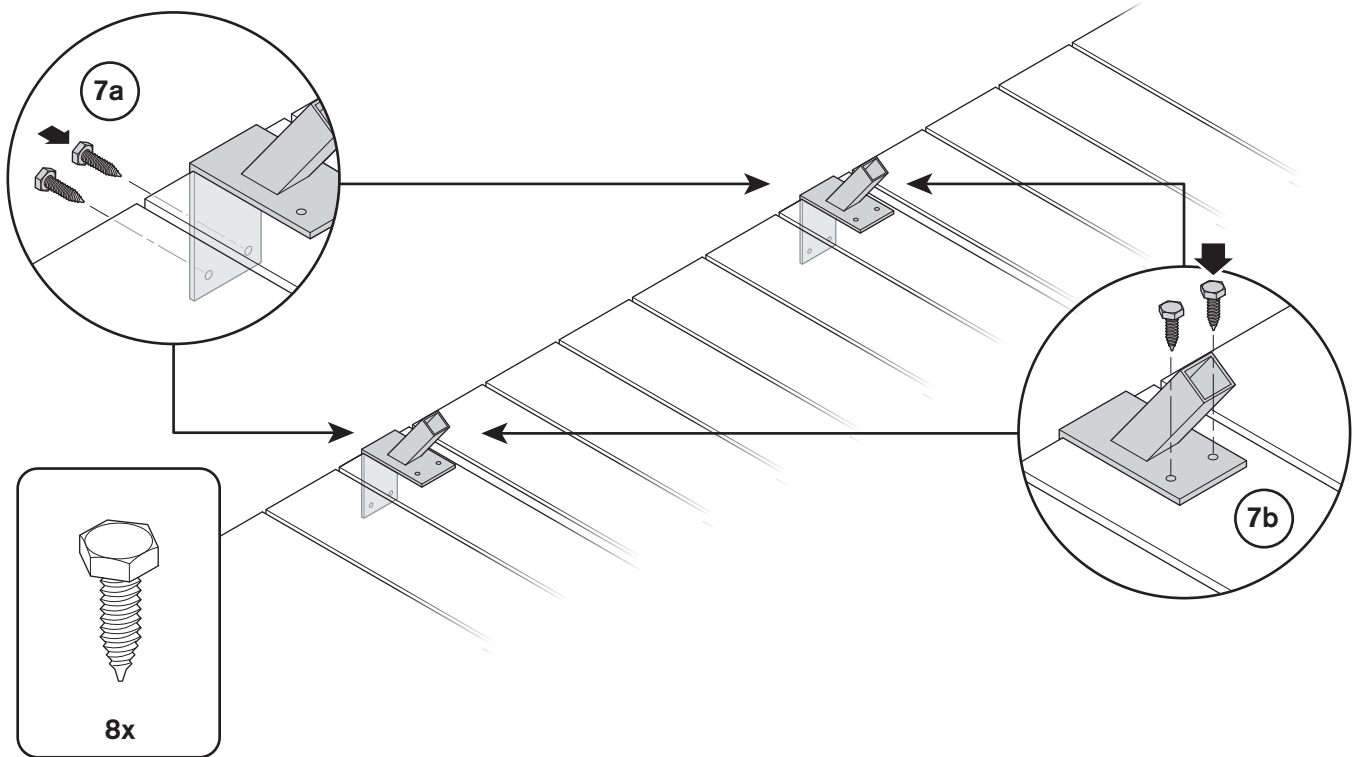

- 8** Place Assembly into each Mount Assembly by inserting the Mount Assembly Dowel Shaft into the Mount Assembly Leg.

