

HOW TO DIAGNOSE INTAKE SYSTEM & VACUUM LEAKS

This procedure will locate leaks in vacuum lines as well as manifolds, EGR valves, oil seals, gaskets, solenoids, o-rings, ducting, throttle shafts, diaphragms, canisters, and more

For best results, test in a draft-free area

1. Remove the air filter housing from ducting
2. If the vehicle has a round inlet tube from the air filter, place the Cone Adapter into the duct toward the engine
3. Put Vapor Supply Hose into Cone Adapter to introduce vapor into the system
4. Use provided Halogen Inspection Light to locate leaks

ALTERNATIVE METHOD

1. Select an appropriate vacuum line to access the vacuum system (i.e. a brake booster supply line before the check valve)
2. Seal all system openings
 - Air Intake must be sealed to prevent vapor from leaking back through the intake
 - To seal the intake, use Cap Plugs, a latex glove, or plastic wrap around the filter
3. Put Vapor Output Hose into Cone Adapter to introduce vapor into the system. Use provided Halogen Inspection Light to locate leaks.

HOW TO DIAGNOSE EXHAUST LEAKS

This test is most effective when exhaust system is cold thermal expansion may cause small leaks to seal

1. Insert appropriate Cone Adapter into the end of the tailpipe. If the vehicle has dual exhaust with cross over system, plug the other tailpipe to seal the system
2. Put Vapor Output Hose into Cone Adapter to introduce vapor into the system

A hot catalytic converter may consume some of the vapor

⚠ All testing is performed with the engine off

SPECIFICATIONS

Power Supply	12 Volts DC
Power Consumption	12 amps
Output Pressure	0.5 PSI / 13.0 in. H ₂ O / 0.032 BAR
Operating Temperature	0°F to 140°F (-17°C to 60°C)
Operating Modes	Vapor Cycle / Air Only Cycle
Pressure Supply	Compressed Air
Housing Material	Steel
Dimensions	6" (15 cm) x 7" (18 cm) x 7" (18 cm)
Machine Weight	7.6 lbs (3.45 kgs)
Shipping Weight	13.85 lbs (6.28 kgs)
Limited Warranty	1 Year

MAINTENANCE

DRAIN VAPOR HOSE

Elevate the machine

Allow the entire vapor hose to hang downward

Place a container beneath the nozzle to capture fluid

Process takes approximately 5 minutes

TROUBLESHOOTING

PROBLEM	SOLUTION
No Green Light	Check polarity Ensure 12-Volt battery is fully-charged Reconnect power cables
Red Light Flashing / No Red Light	Ensure 12-Volt battery is fully-charged Open circuit / internal component Contact Redline Detection Technical Support
No Air Flow	Check connection to compressed air Open the flow control valve Check hoses are not kinked
Not Enough Vapor	Check Fluid Level Open the flow control valve Check hoses are not kinked
Gauge Bouncing Flow Meter Bouncing	Drain Vapor Hose

REDLINE TECHNICAL SUPPORT

RedlineDetection.com/support

TechSupport@RedlineDetection.com

+1 714-451-1411

Monday - Friday: 7:00 to 17:00 PACIFIC TIME

Stay Connected

[Facebook.com/RedlineDetection](https://www.facebook.com/RedlineDetection) and [Twitter @RedlineDetect](https://twitter.com/RedlineDetect)

WARRANTY

The manufacturer, Redline Detection, LLC. ("Redline") warrants this product to be free from defects in workmanship and material under normal use and service. This limited warranty is extended to the original end-user purchaser and is valid for one year from date of manufacture. Redline's liability under this warranty is limited to:

(1) Repair or replacement of any parts or product which are determined to be defective; or at Redline's sole option

(2) Refund of the purchase price. In either event, product to be returned shipping prepaid within the one year warranty period. Products are only to be used by persons having skill and knowledge in the automotive repair field, and improper use or maintenance may cause serious injury. In no event shall Redline be liable beyond replacement of product or refund of the purchase price. This warranty shall void if a product is improperly maintained, altered, abused or otherwise misused in any way.

The limited warranty does not cover defects or malfunction caused by misuse, abuse, or failure to follow operating instructions. It doesn't cover cosmetic or incidental damages or machines that have fully or partially disassembled. Also, the warranty will not apply to damage caused by unauthorized alteration, modification or repair of the product.

THE AFORESAID WARRANTY IS IN LIEU OF ALL OTHER WARRANTIES, AND THERE ARE NO OTHER WARRANTIES OR REPRESENTATIONS OF ANY KIND WHATSOEVER MADE BY REDLINE, EITHER EXPRESSED OR IMPLIED, INCLUDING BUT NOT LIMITED TO, ANY IMPLIED WARRANTY OF MERCHANTABILITY OR FITNESS FOR A PARTICULAR USE OR APPLICATION.

THE PURCHASER'S SOLE REMEDY FOR ANY DEFECTIVE PRODUCT SHALL BE REPAIR, REPLACEMENT OR REFUND AS STATED ABOVE AND REDLINE SHALL NOT BE LIABLE TO ANYONE FOR ANY SPECIAL, CONSEQUENTIAL, INCIDENTAL, INDIRECT OR PUNITIVE DAMAGES ON ACCOUNT OF DEFECTIVE PRODUCTS, HOWEVER CAUSED, UNDER ANY THEORY OF LIABILITY.



OPERATION MANUAL

P/N 95-0400

REDLINE
DETECTION.COM

COMPONENTS

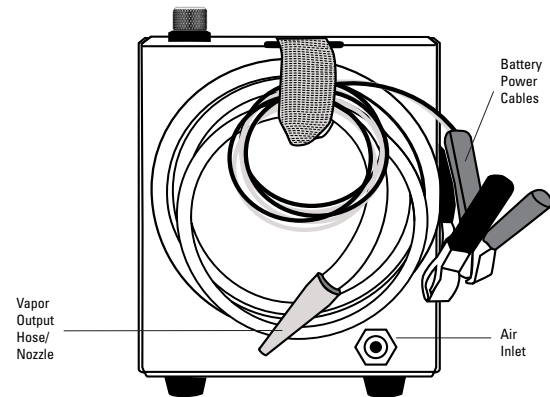
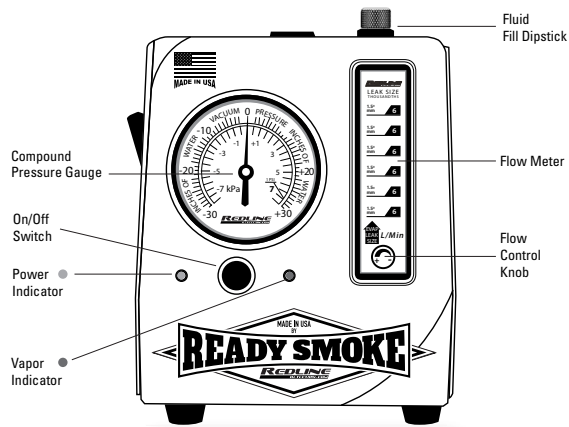

SAFETY

The procedures in this operation manual are intended to be basic guidelines for users to practice using this ReadySmoke

This operation manual is not intended to be used in place of common sense:

- Use this equipment in the manner specified by the manufacturer
- Understand operating procedures
- Follow all safety precautions

SAFETY PRECAUTIONS

- All diagnostic work should be performed with the engine off
- Do not leave a vehicle unattended while equipment is connected or operating
- Equipment operates on a 12 Volt battery
Connect machine to battery (+) and chassis ground (-)
- Do not perform tests near a source of spark or ignition
- When working with the fuel system, work in a well-ventilated area
- Always wear the appropriate safety protection

- ⚠ Wear OSHA standard eye wear and protective gloves when using this equipment
- ⚠ Always use a supplemental hood support or prop rod whenever hanging unit under a hood

SET UP

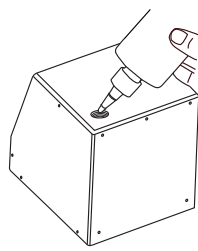

1. FILL / ADD VAPOR PRODUCING FLUID

Remove Fluid Fill Dipstick. Pour Vapor Producing Fluid into Fluid Fill Port until fluid level is near top of the fill line on the Dipstick. Replace Fluid Fill Dipstick

- ⚠ Do not overfill
First time fill requires approx. 2 oz (60 ml)
Check fluid level every 50-100 tests
- ⚠ Never use dyes, solvents or other contaminants in intake or exhaust systems because they may coat and/or harm critical sensors, catalysts or filters

▲ Fill Fluid to Maximum Fill Line on Dipstick

HOOK UP CONNECTIONS

2. CONNECT TO POWER

This machine runs on a fully-charged 12-Volt battery
Connect red lead (+) to battery's positive terminal
Connect black lead (-) to chassis ground

- ⚠ Do not connect to battery charger or jumper box
- ⚠ Do not exceed 13.8V DC

POWER INDICATOR:

- Green Light: Machine has adequate power
- No Light: No Power, See Troubleshooting Section

3. CONNECT TO AIR SUPPLY

Connect Air Input Hose to a compressed air supply
If necessary, replace Air Fitting to match your air supply

TESTING FOR LEAKS

4. PUSH ON / OFF SWITCH

Begins 5-minute vapor cycle

VAPOR INDICATOR:

- Red Light: Vapor is Generating
- ◻ Flashing Red Light: Open Circuit, See Troubleshooting Section
- No Red Light: No Vapor Generating

Turn Flow Control Knob counter-clockwise to release vapor pressure

Flow Meter indicates flow and measures leak size

Use provided Halogen Inspection Light to locate leaks

Perform repair(s) as needed

VERIFY REPAIRS

5. PERFORM DECAY / LEAK DOWN TEST

Pressurize the sealed system

Lock out system by turning Flow Control Knob clockwise to the fully closed position

OBSERVE PRESSURE GAUGE FOR DECAY:

- ⌚ Pressure Holds: No leaks, Repair is complete
- ⌚ Pressure Decreases:
Leak(s) exist, Repeat Steps 5 & 6 until all repairs are complete

NOTE: Not all systems are designed to be 100% sealed

HOW TO DIAGNOSE EVAP LEAKS

Leaks in the EVAP system, or fuel vapor recovery system, are frequently the cause of check engine lights. Using ReadySmoke, these leaks can be quickly diagnosed and repaired, making them profitable services for repair facilities

PRESSURE DECAY / LEAK DOWN TEST

1. Verify if a leak is currently present, test the EVAP system using the Decay or Leak Down testing method with air only
 - a. To access the EVAP service port, remove the green cap
Remove Schrader valve using the provided Schrader Valve Removal Tool (Schrader valve has left-handed threads, turn clockwise to remove)
 - b. Using a scan tool, close the vent solenoid to close EVAP system from atmosphere (If vent solenoid does not close, intermittent solenoid may have failed)
 - c. Input air into EVAP system until fully pressurized. When pressure gauge reaches its maximum pressure (12-14 inches of water column), Flow Meter will indicate leak size (if leak is present)
 - d. Lock out system by turning the Flow Control Knob to the fully closed position. Observe pressure gauge for decay
 - e. If no leaks are present, system will hold pressure
 - f. If pressure decays or leaks down, leaks exist. Proceed to step 2 to find leaks
2. Push ON / OFF switch to begin 5 minute vapor cycle
3. Remove the fuel cap
4. Open Flow Control Valve to input vapor into the system through adapter
5. Replace fuel cap when dense vapor is seen exiting the filler neck
6. Continue pumping vapor into the system
7. Using the provided Halogen Inspection Light, inspect for leaks (under the hood and tracing the route of the EVAP system on the underside of the vehicle)
8. Repair the system as needed
9. Repeat procedures in steps above until all repairs are complete and final quality test is performed, indicating no leaks