



OWNER'S MANUAL
RCR V2.0

onyxmotorbikes.com

info@onyxmotorbikes.com

(310) 800 2531

1924 E Maple Ave.

El Segundo, CA
90245





WELCOME

YOU ARE NOW THE PROUD OWNER OF AN ONYX MOTORBIKE.

In this document we will cover the basic landscape and maintenance of the electric bike.

We want to thank you for choosing ONYX as your new form of transportation and recreational use. We welcome you to the ONYX riding community. We hope you use this manual to provide for reference in the operation, inspection and basic maintenance of your ONYX. We are constantly updating and refining our product. This manual contains the most up to date information bikes built during 2018—present. Please to use this document to keep yourself up to speed for many enjoyable miles to come.

Sincerely,
ONYX Motorbikes

GET IN TOUCH

onyxmotorbikes.com
(310) 800-2531
info@onyxmotorbikes.com



ONYX Motorbikes Group
[facebook.com/groups/
onyxmotorbikes](https://facebook.com/groups/onyxmotorbikes)

WARNING

Riding an electric bike is extremely dangerous. Use of this product can result in serious damage, injury, or death. ONYX products function differently from conventional bicycles and are dangerous. To minimize risk of serious injury, protective equipment should be worn at all times including a helmet. You are responsible for your own safety. Use this product with extreme caution and at your own risk.

CONTENTS

QUICK START GUIDE

8

LET'S GET READY TO RIDE!
CHECKING AND PREPPING THE BIKE FOR THE FIRST
RIDE BASIC BATTERY CHARGING PROCEDURE
USEFUL RIDING INFORMATION

SAFETY INFORMATION

1

GENERAL SAFETY INFORMATION
OPERATING SAFETY INFORMATION
IMPORTANT LABELS & WARNINGS

6

GENERAL INFORMATION

1

STANDARD RCR MODEL TECH SPECS
OPTIONAL EQUIPMENT SPECS
ACCESSORIES SPECS
TYPICAL RCR MODEL DISTANCE
RANGE

8

OPERATING CONTROLS

32

MODEL RCR FEATURES OVERVIEW

HEADLIGHT
BRAKE LIGHT
PEDALS
BATTERY
COVER
BATTERY
LOCATION REAR
HUB MOTOR
ELECTRONICS COMPARTMENT

HANDLEBAR CONTROL FEATURES

OVERVIEW LCD DASH DISPLAY OVERVIEW
SET CLOCK
RIGHT SIDE
CONTROLS LEFT SIDE
CONTROLS

KEY-FOB BUTTON LAYOUT AND OPERATION
OPTIONAL ACCESSORY OVERVIEW

OPERATING INSTRUCTIONS

42

GENERAL OPERATION
THROTTLE, BRAKING, PARKING
BATTERY OPERATION, CHARGING AND STORAGE
BATTERY OVERVIEW
BATTERY COVER
REMOVAL
BATTERY REMOVAL + INSTALLATION
BATTERY CHARGING AND
CHARGERS BATTERY BALANCING
BATTERY STORAGE
BATTERY MAINTENANCE AND SAFETY TIPS

MAINTENANCE

62

OWNER RESPONSIBILITIES
RECOMMENDED MAINTENANCE AND SERVICE
SCHEDULE BASIC RCR MODEL MAINTENANCE
CLEANING
BODY PARTS & SKINS SERVICE
CHECK YOUR NUTS & BOLTS
CHECK YOUR ELECTRICAL
STUFF BRAKE SERVICE
WHEEL & TIRE
SERVICE CHAIN &
FREEWHEEL LONG
TERM STORAGE

FASTENER

LOCATION TORQUE

TROUBLESHOOTING

66

RCR MODEL ELECTRIC MOTORBIKE
PRECAUTIONS
COMMON TROUBLESHOOTING
ADDITIONAL TROUBLESHOOTING RESOURCES

TERMS & CONDITIONS

70

GENERAL INFORMATION
PURCHASE, PAYMENT & PRICING
SHIPPING PRODUCTS OTHER THAN ONYX BIKES
DISCLAIMER & LIMITATION OF LIABILITY
RETURNS & EXCHANGES
WARRANTY & COMPLAINTS
PRIVACY POLICY
COOKIE POLICY

NOTES

82

FIRST RESPONDER INFORMATION

83

HIGH VOLTAGE LOCATIONS

CALIFORNIA PROPOSITION 65

WARNING: Operating, servicing, or maintaining a passenger vehicle or off-highway motor vehicle can expose you to chemicals including engine exhaust, carbon monoxide, phthalates, and lead, which are known to the State of California to cause cancer and birth defects or other reproductive harm. To minimize exposure, avoid breathing exhaust, do not idle the engine except as necessary, service your vehicle in a well-ventilated area and wear gloves or wash your hands frequently when servicing your vehicle. For more information go to www.P65Warnings.ca.gov/passenger-vehicle.

CALIFORNIA PERCHLORATE ADVISORY

WARNING: Certain components of this motorbike such as lithium batteries may contain perchlorate material. Special handling may apply for service or end of life disposal. See www.dtsc.ca.gov.

QUICK START GUIDE



RCR MODEL

LET'S GET READY TO RIDE

Okay you are super tempted to ride the bike, but lets get the bike fully charged and ready to ride before you go ride off into the sunset. Your bike will come fully charged when shipped. If you ride the bike uncharged you could cause problems with operating the bike. So lets get started!

Whether you are a seasoned cyclist or new to the electric motorbike scene, riding an ONYX Motorbike is an awesome experience every time and everywhere you get to ride one. Pedaling your heart out is great exercise and gets the blood flowing for sure, but being able to twist the throttle to give you power whenever you need it gives you a rush and a thrill like nothing else! However, there are some general riding considerations to understand and keep in mind your electric motorbike that will keep you and others around you safe and happy.

PRE-RIDE SAFETY CHECK

Before every ride, it is the owner responsibility to check and maintain your vehicle according to the schedule below unless service is needed otherwise:

- + Check the Headlight, Tail Light, & Any Other Installed Lighting for Proper Operation
- + Check Tire Rotation – Should Spin Smooth & Straight
- + Check Tire Pressure (32 psi F&R)
- + Check Front & Rear Brake Operation
- + Check Battery Charge Level
- + Check & Torque Fork, Axle, Handlebar, and Suspension Nuts (see *General Information > RCR Torque Specifications, page 27*)

PREPARING FOR THE FIRST RIDE

Wear properly fitting protective gear including at minimum: full-face helmet, gloves, long pants, long sleeve bright colored shirt, full-toed shoes, and a reflective vest. Do not wear loose fitting pants or shoes that can get caught in the chain, pedals, or wheels. Additional items that can make your riding experience safer, better, and more comfortable can include sunglasses (that will fit and work with your helmet) and a jacket. Be careful wearing anything that can limit your flexibility, mobility, or vision.

If your locale does not require you to obtain and maintain a valid motorcycle/moped driver's license, ONYX Motorbikes strongly recommends that you do so anyway. In addition to learning more about and being tested on knowing the rules of the road for safety reasons, having a moped/motorcycle driver/rider license will help put any law enforcement agent at ease in case they question your ride or ability to ride... Additionally, even if your locale does not require you to complete any formal training, ONYX Motorbikes strongly recommends that you take a moped or motorcycle riding course for proper training, especially if you are new to motorbikes in general. Contact your State or local Department of Motor Vehicles or law enforcement agency for any recommendations or suggestions on training programs or courses. These courses will often count as partial or full credit for obtaining your motorcycle/moped driver's license!

Be sure to attend to the following before your first ride:

- + Be sure to switch on headlight at low visibility. When your bike is on there will always be a running light halo on.
- + Obey all traffic regulations.
- + Use hand signals when turning or changing lanes. Please respect property of others and ride carefully. Keep your feet on the pedals at all times. Keep the pedals level, especially on turns.
- + After reaching maximum speed, reduce the throttle opening to 3/4. While the reduction in speed will hardly be noticeable, energy consumption nonetheless will be considerably reduced.
- + Remember that regenerative (regen) braking is very strong and can sometimes slow the bike to a stop alone but it can be unreliable especially at a full battery charge. So always use the regen brake feature with caution.

1

0



RCR MODEL

BASIC BATTERY + CHARGING GUIDE

Getting the maximum performance out of the Onyx RCR requires taking great care of its battery. For detailed battery and charging information see *OPERATING INSTRUCTIONS, BATTERY OPERATION, page 44*.

CHARGING THE BATTERY

Constantly removing the battery from the Onyx RCR itself and **removing wood cover constantly is not necessary to charge the Onyx RCR battery.**

There is an open port in the front of the body to slide out the XLR charging cable. Plug the the charger into a standard wall electrical outlet before plugging the stock charger cable into the batteries XLR charging cable.

If you do remove the battery, place a small towel in the gap between the seat and wood battery cover to protect your seat from scratching when removing the battery cover.

CONSTANT VOLTAGE CHARGING

When the (Standard 5 Amp) Onyx RCR charger light turns green that means 97% (83.3 volts) of the charge is complete. The remaining 3% to charge to 100% (84.0 volts) takes 95 more minutes after the charger light turns green. This last 3% is called “constant voltage” and is done through trickle charging.

It is okay to charge (5 amps) the Onyx RCR to 97% (83.3 volts) (charger light turns green) and go for a ride. But this means that when your battery gets below 68 volts, it may cut out sooner.

BATTERY SAG

Become familiar with the amount of battery sag full throttle causes in eco mode, normal mode, and sports mode. Sag is described as the amount of electricity drawn depending on how much throttle is given. On a colder day it is not uncommon at full throttle for the voltage sag to be 7 volts and on warmer days for it to be between 4 volts to 5 volts.

- Each mode limits the amount of sag.
- Eco mode will help prevent cut offs by reducing battery sag.
- The amount of throttle given directly controls the amount of battery sag.

BATTERY CUT OFF

When the amount of battery sag falls below 59 volts with a 23ah battery, the Onyx RCR will turn off.

Cut off occurs because the battery management is protecting the batteries from damage. If it completely cuts out you will need to toggle physical on/off switch on your battery and use your key fob to unlock the bike.

One way to prevent the Onyx RCR with 23ah battery from completely cutting off is to immediately activate regenerative braking by using your rear brake.

If you have a 41ah battery and your voltage drops below 56 volts, the battery will cut out and immediately come back on after 10 seconds.

PRO TIP
S

- + Riding faster consumes more battery.
- + Become familiar with how many miles away your destination is going to be.
- + Keep your battery charge levels above 20 percent which is 69.9 volts (67 with 41ah battery) on the display voltmeter.
- + How well the battery is taken care of directly impacts the Onyx RCR's performance, battery sag and top speed.

1

2



RCR MODEL

5: To fully remove the battery for charging, turn the battery off using the switch (use ONYX app if 41ah) grab the battery case handle and lift out the front of the battery first until it clears the top of the bike. In the meantime, make sure to gently help the battery cables out of the bike.

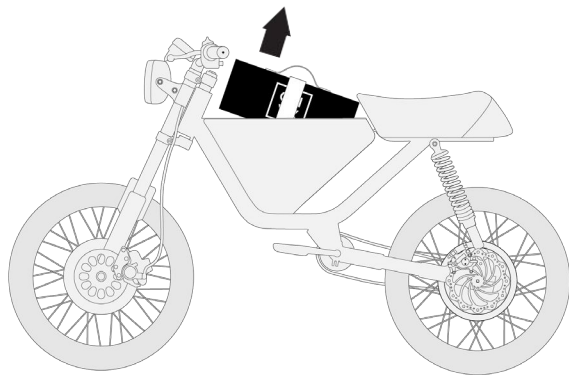

6: Plug in the charger into the wall and then plug in your battery. The charger light will change from green to red after the battery is connected. When the battery is done charging the light will turn green.

7: After the charge is complete make sure the battery switch is in the “OFF” position before installing the battery. Note: the 41Ah battery does not have an ON/OFF switch and is operated via bluetooth-enabled ONYX BMS App.

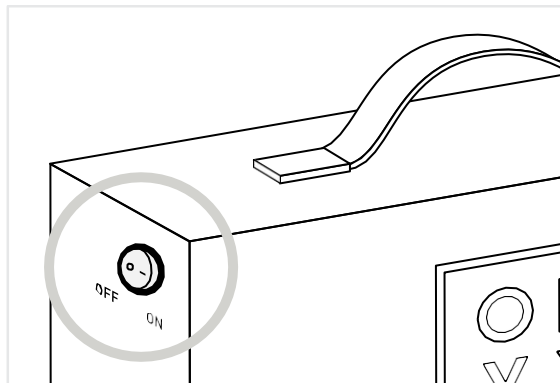

8: Place the back end of the battery on the battery tray first then sit it down the front gently moving the cables into the bike.

9: Plug in the red battery discharge cables. Do not be alarmed if you forgot to turn off the battery and the connectors spark on contact. This is okay a few times but over time this can wear out your connector.

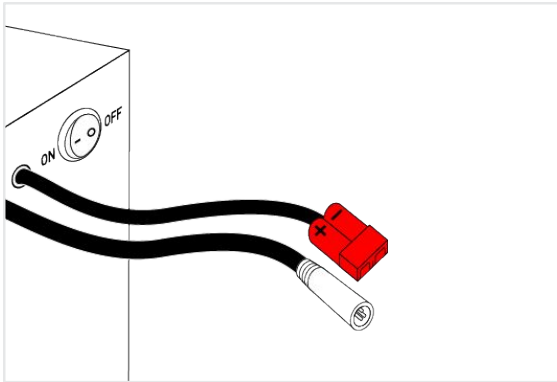

10: Grab both ends of the battery strap and buckle it back together (adjust for a snug fit if necessary). Once the battery is secure you can turn the battery power to the "ON" position.

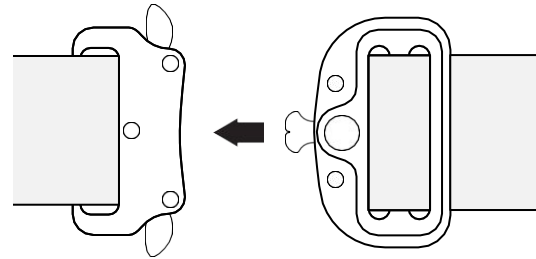

11: Read the Operating Controls (*page 30*) before attempting to turn on the bike.



USEFUL RIDING INFORMATION

BEFORE YOU RIDE...

Research and understand your local laws and classifications where you live as well as where you intend to ride!

ONYX Motorbikes recommends that you register and insure your motorbike in one way or another if you want to and IF YOU NEED TO. Please consult your local laws.

Respect the environment, and tread lightly. Don't tear up or ride off of designated roads and trails. It is cool to blaze your own trail sometimes, but make sure it is OK to do so without damaging the local vegetation or animal population!

Be aware of your surroundings. Remember that e-bikes are quiet. Be aware of joggers, people pushing strollers, and other cyclists that may be on or near the paths and lanes that you may be using.

Consider installing some or all of the following items as they can help or enhance your riding experience, safety and visibility on the public roads with other drivers:

- + Front & Rear Turn Indicator Lights
- + Rearview Mirrors
- + Front and/or Rear Wheel Fender(s)
- + License Plate (with a light to illuminate the plate)
- + Front & Rear Side Reflectors

Visit onxymotorbikes.com to purchase some of the available accessories.

Whether you are a seasoned cyclist or new to the electric motorbike scene, riding an ONYX Motorbike is an awesome experience every time and everywhere you get to ride one.

HAND SIGNALS

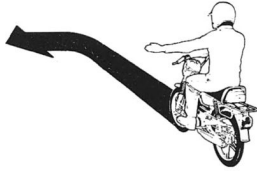

LEFT TURN

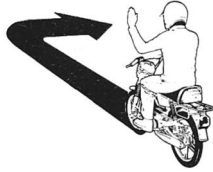

RIGHT TURN



STOP



SAFETY INFORMATION

GENERAL SAFETY INFORMATION

This is a high performance electric motorbike and should be treated with extreme caution. Proper safety gear, including a regionally approved helmet, eye protection, riding boots, gloves, and protective clothing should be worn while riding to reduce the risk of potential injury.

Never permit a guest to ride your electric motorbike without proper instruction. Never use alcohol or mind-altering drugs before operating your electric motorbike. The owner assumes all responsibility while operating their motorbike. The seller assumes no liability for misuse or operator negligence.

Prior to each use the rider must check everything in the “Pre-Ride Safety Check” section of the Quick Start Guide.

Modifications and additional loads may affect your bikes performance, handling, range and operation. Use caution.

OPERATING SAFETY INFORMATION

Your safety depends in part on the good mechanical condition of the motorcycle. Be sure to follow the maintenance schedule and adjustment requirements contained in this manual. Be sure you understand the importance of checking all items thoroughly before riding and abiding by the local, state, and federal laws.

IMPORTANT LABELS & WARNINGS

Read all additional warnings and product instructions in this owner’s manual, as well as safety labels, before operating your electric motorbike. *(SEE BATTERY SAFETY TIPS, page 44)*

IDENTIFICATION NUMBER LOCATIONS

FRAME NUMBER LOCATION

The frame number is etched underneath the rear seat down tube.

MOTOR SERIAL NUMBER LOCATION

The motor number can be found on the pedal chain side etched on the hub motor's side cover plate. The motor number starts after the ONYX.

VIN NUMBER

All models to date do not have a VIN number. ONYX bikes do however have a motor and frame serial number.

FOB CODE

The FOB code is found on your key FOB.

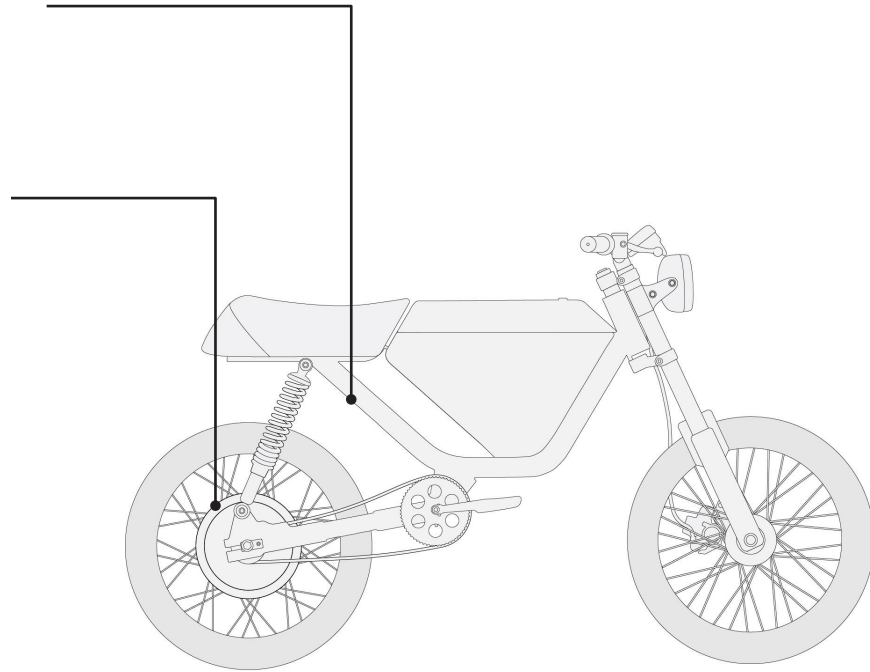



GENERAL INFORMATION

STANDARD RCR MODEL TECH SPECS

ONYX Motorbikes reserves the right to make changes to the product information contained on this site at any time without notice, including with respect to equipment, specifications, models, colors, and materials.

GENERAL VEHICLE INFORMATION

ITEM	SPECIFICATION		
Drivetrain	100% Electric Direct-Drive Rear Hub Powertrain		
Transmission	Clutchless Shiftless Direct Drive Rear Hub Motor		
Drive Modes	ECO ¹ = Economy	NRM = Normal	SPT = Sport
Motor Power (continuous)	750W (governed) ¹	1,500W (limited)	3,000W (limited)
Riding Range	75 miles ¹	40 miles	20 miles
Top Speed (limited)	20 mph ¹	38 mph	60 mph (max.)
Pedal Assist	Full-Function, but Passive-Assist (not pedelec)		
Battery Type	Single Removable 72V Lithium-Ion Battery Pack in Heavy-Duty Metal Case		
Anti-Theft Protection	Anti-Theft Power Lock + Multi-Function Remote Alarm Key Fob		
Front Fork/Suspension Design	Heavy-Duty Motorcycle Forged Aluminum Fork		
Rear Suspension	Swingarm with Double 350mm (300mm for SHRTY) Adjustable Coilover Shock Absorber		
Brakes	Front & Rear Disc Brakes with Binary Power Regeneration		
Tires	17" Diameter x 2.75" (3.00" on newer modles) Wide		

Headlight	Powerful Harley-Style 3-Element LED Bright White Projector Headlight with Halo Ring Running Light
Tail Light	Bright Red LED Brake Tail Light with Running Light
Frame	Automotive Grade Steel Tube Chassis and Strong Battery Holder Tray Chassis
Display	LED Backlit Multi-Function Speedometer, Clock, Odometer, Battery "Gas" Gauge, Battery Voltage Reading
Basic Dimensions	Compact 67" Long x 40" Tall x 27.5" Wide
GVWR - Gross Vehicle Weight Restriction	506 lbs. (229 kg)
Total Curb "Wet" Weight (with battery)	156 lbs. (71 kg)
Maximum (Payload) Carrying Capacity (including rider, installed accessories, and gear)	350 lbs. (158 kg)
Total "Dry" Weight (without Battery)	131 lbs. (59 kg)
Front Axle Weight Distribution	64 lbs. (29.2 kg); 41%
Rear Axle Weight Distribution	92 lbs. (41.8 kg); 59%

BATTERY INFORMATION (Battery Cell information, see *OPERATING INSTRUCTIONS, BATTERY OPERATION*, page

ITEM	SPECIFICATION
Charge Capacity	23 Ah (or 41 Ah)
Battery Weight	25lbs (41 Ah 36lbs)
Battery Dimensions	14" long x 3" wide x 5" tall (41 Ah 14.17" x 7.28" x 5.12")
Battery Cell Components	18650 2900mAh 10A batteries (41ah uses 21700 cells)
Battery Cells	Customized 20S8P Lithium battery pack (41 Ah uses 20S9P)
Voltage Cut Off	The BMS is programmed to cut off at 85 volts to 59 volts (with 41ah 56 volts).
Recommended Voltage Charge Rate	Recommended voltage charge and discharge range is between 84 volts and 60 volts [56 with 41ah].

**ELECTRONICS INFORMATION**

ITEM	SPECIFICATION
LCD Dash Display	Bright Multi-Function LCD Display in Streamlined Housing with Current Speed, Charge Level Indicator, Odometer, Trip Odometer, Voltage Reading
LCD Dashboard	Drive Mode Indicator (ECO, NRM, SPT), Headlight Indicator, Left/Right Turn Indicator (optional function)
Front Headlight	Multi-Function LED Headlight, LED Ring Running Light (always on), 3-Element High Power LED
Rear Tail Light	Red LED Tail Light with Brake Light
Throttle	Half-Grip Twist Throttle with Kill Switch and Mode Select Switch
Battery Nominal Voltage - Output	72 VDC
Battery Case Dimensions	14.125" x 4.375" x 6.625" (358 mm x 111 mm x 168mm)
Battery Weight	25 lbs. (11.3 kg). 41 Ah - 36lbs
Operating Voltage Range	59-84 VDC (41 Ah 56-84 volts)
Maximum Charge Voltage	84 Volts +/- 2%
Battery Capacity	23 Amp-hour / 1,656 Watt-hour (1.6kWh) - 41 Amp-hour / 2,952 Watt-hour (2.9kWh)
Rated Current	55 Amps (constant current, discharge)
Peak Current	~70 Amps (maximum current measured under 3000 Watt motor load)
Typical / Max Charge Current	5 Amps - Recommended Standard / 10 Amp Maximum
Battery Cell Type	High-Quality 3.7V Lithium Ion - NCM (Nickel Cobalt Manganese Oxide Based) 18650 Cells (41ah 21700)
ONYX Battery Pack Configuration	20S8P (20 Serials (20S) 8 Parallels (8P)) - 41 Ah 20S9P
Battery Pack Cell Matching & Grouping Tolerances	Cell Capacity Gap = +/- 30 mah; Cell Voltage Gap = +/- 5 mV; Cell Internal Resistance Gap = +/- 3 mOhm
ONYX Battery Management System (BMS)	Integrated Battery Battery Management System (BMS manages safe and efficient charging and balancing of each and all battery cells as a system to maintain battery life and performance)
ONYX Battery BMS Management Scheme	The BMS has an overcharge voltage protection function that detects and protects single cells in addition to serial groupings that will cut off charging to 4.25 V +/- 50 mV (recover at 4.15 V +/- 50 mV). The over-discharge cutoff is 2.8 V +/- 80 mV (recover at 2.85 V +/- 150 mV). Also each cell incorporates PTC and CID protections. PTC (Positive Thermal Coefficient) provides external short condition cell protection, and CID (Current Interrupt Device) provides overcharge condition cell protection.



Battery Load Connector	Heavy-Duty Anderson 2-Pole Connector
Battery Charge Cable Connector Type	Metal Case 3-Pin XLR (female)
Battery (Charge Cycle) Life	Rated for 800 Charge Cycles
Battery Charger – Standard Charge	Separate External 84 VDC Output, Fixed Output 5 Amp Smart Charger, 110 VAC and 230 VAC Power Cord
Battery Charger Output	5 Amps @ 84 VDC (recommended; standard rate charger)
Battery Charger Charge Cable Connector Type	Metal Case 3-Pin XLR (male)
Battery Charger Charge Cable Connector Pinout	Male - Pin 1 = DC+ (positive); Pin 2 = DC- (negative); Pin 3 = GND (ground/signal)
Battery Charger Protection Fuse	Replaceable Fast-Blow Fuse
Typical Battery Charge Time – Empty to Full	80% Charge = 2.5 Hours 100% Charge = 4.5 Hours
Motor Controller Type	Electronic Sine Wave
System & Motor Speed Controller Features	High-Efficiency 72V, 3000W (max.) Sinusoidal Wave Brushless DC (BLDC) Waterproof Motor Controller with: Regenerative Power Support During Braking; Hardware Over-Current and Over-Voltage Protection; LED Fault Code; Thermal and Current Cutback Plus Low Voltage Battery Protection Shutdown; Rugged Waterproof Aluminum Housing for Maximum Heat Dissipation; Blue-tooth (Android Support)
Motor Type	4T Turn Count Brushless DC (BLDC) Permanent Magnet 3000W Electric High Power Spoke Rear Hub Motor with 3 Hall Sensors
Max. Motor Peak Torque	142 ft-lb (193N-m)
Motor Rated Power	750W (nominal in ECO Mode) up to 3,000W (maximum)
Motor Environmental Protection	IP54
Motor Temperature Protection	Thermic Probe (sense to prevent overheating)
Anti-Theft Protection Devices	Audible Motion-Activated Alarm with Bike Activation/Deactivation Control and Power Button Fob (set of 2 fobs provided); Uniquely Cut Key Lock for Battery Cover (set of 2 keys provided)
Anti-Theft Alarm dB Level	120 dB
Anti-Theft Alarm Frequency	433 MHz
Anti-Theft Alarm Fob Battery Type	CR2032
Wiring	Complete Insulated and Wrapped Wiring Harness with Automotive Water-Resistant Connectors

**MECHANICAL INFORMATION (continued)**

ITEM	SPECIFICATION
Frame	Automated Robot-Formed and Welded Tubular and Plate Steel Construction
Fork	Heavy-Duty ONYX-Designed Non-Adjustable Motorcycle Fork with Steel Fork Brace
Fork Spring Stiffness	Heavy-Duty ONYX-Designed Non-Adjustable Motorcycle Fork with Steel Fork Brace
Fork Suspension Travel	3" (80 mm)
Body Panel Material	Formed Aluminum, Silver
Battery Cover Material	5 Ply Laminated Mahogany Plywood with Brown Stain
Headtube Length	5.7" (145mm)
Handlebar	7/8" DIA Tubular Steel 27.5" (700 mm) Wide 22mm outer diameter
Handlebar Rise	2" (51 mm)
Dropout Width – Front	4.25" (108 mm)
Dropout Width – Rear	5.75" (150 mm)
Brake System Type – Front	Single-Piston Hydraulic 220 mm DIA Hydraulic Disc Brake
Brake Operation – Front	Right Hand
Front Brake Type	Single-Piston Hydraulic 220 mm DIA Hydraulic Disc Brake with Braided Stainless Steel Brake Hose
Front Brake Rotor Disc	Cross-Drilled Slots 220 mm DIA x 5 mm THK
Front Brake Fluid Type	DOT-3
Front Brake Caliper Style	ZUMA50 BWS YW50 Front Left
Front Brake Pad Type Material	Semi-Metallic; Powerful Initial Bite with Long Life and Thermal Stability Up to 1100 °F
Front Brake Pad Style	Yamaha Zuma 50 02-11, 49mm (61mm w/tabs) x 27mm x 4 mm THK (NOTE: Replacement must match shape and configuration.)
Brake System Type – Rear	Dual Piston Line-Pulled Hydraulic 205mm DIA 6-Bolt (Pitch Circle Diameter = 44 mm) Drilled Disc Brake; Regenerative Braking Energy Recovery System
Brake Operation – Rear	Left Hand
Rear Brake Type	High-Strength Aluminum Alloy Material HB-100 Single Piston Line-Pulled Hydraulic Disc Brake

Rear Brake Rotor Disc	Cross-Drilled 205 mm DIA x 1.9 mm THK (8" DIA x 0.07" THK) with 6 Low-Profile Head Mounting Screws
Rear Brake Pad Material	Semi-Metallic
Rear Brake Pad Style	Mountain Bicycle (MTB), 34.2 mm x 26.6 mm x 4 mm THK (NOTE: Replacement must match shape and configuration.)
Bicycle Gearing	1 x 1-Speed
Bicycle Crank Gear Set	38-Tooth, 6.38"DIA (162 mm) Forged Alloy Gear
Rear Freewheel Sprocket	16-Tooth Gear
Bicycle Chain	1/8" Track x 1/2" Wide Bicycle Chain
Grips	Durable Black Vinyl
Kickstand	Side-Mount Heavy-Duty Single One-Piece Aluminum Single Stand Arm with Heavy-Duty Spring
Bicycle Crank Arm Length - Overall	6" (152 mm)
Bicycle Crank Arm Shaft Length - Center-to-Center	4.875" (124 mm)
Pedals	Nylon Platform with Traction Nubs, Standard 9/16" x 20 TPI Threading
Seat	Durable Vinyl Coated Comfortable Medium Density Foam
Rear Rack (optional)	Hardware-Mounted Black Powder Coated Aluminum Frame, 5" Long x 6.25" Wide (optional – purchased separately or in DRT Kit Package)
Fender – Front (optional)	Black Plastic Full Coverage Dirt Bike Style
Front – Rear (optional)	Black Plastic Partial Coverage with Integrated LED Red Tail/Brake Light (optional – purchased separately or in DRT Kit Package)
Headlight Grill (optional)	Black Waffle Weave Front Protective Grill

**WHEEL + TIRE INFORMATION**

ITEM	SPECIFICATION		
Tire Options	17" DIA x 2.75" Wide All-Weather Street (standard) <i>OR</i> 17" DIA x 2.75" Wide Knobby Tires (optional – purchased separately or in DRT Kit Package). New bikes use 3".		
Wheel Rim Type	17" DIA x 2.75" W with Laced Spokes		
Wheel Spoke Type	12 Gauge Stainless Steel, Silver		
Tire Configuration	Spoke Rim + Inner Liner + Inner Tube + Tire		
Standard Tire Size	2.75-17 (2.75" W x 17" Inner Dia.)		
Maximum Tire Width	3" Front & Rear		
Tire Options	OEM Street Tire, Mitas Mediterra (primary OEM)	OEM Street Tire, Michelin CITY PRO (alternate OEM)	Optional Off-Road Tire, Cheng Shin (optional)
Tire Manufacturer	Mitas	Michelin	Cheng Shin
Tire Model	MC51 Mediterra M/C	CITY PRO	C183A Intermediate MX Knobby
Primary Tire Application	All-Season Street On-Road & Light-Duty Off-Road	All-Season Street On-Road & Light-Duty Off-Road	All Season Non-Pavement Soft Surface Off-Road
Tire Tread Pattern Description	Wheat-Ear	Wheat-Ear with Open Center Channel	Knobby
Tire Tread Image			
Tire Width	2.75"	2.75"	2.75"
Rim Size	17"	17"	17"
Tire Position	Front/Rear	Front/Rear	Front/Rear
SideWall	Blackwall	Blackwall	Blackwall
Tire Load Rating	47P (maximum 386 lbs. per tire)	47 (maximum 386 lbs. per tire)	Maximum 335 lbs. per tire @ 32 psi

OEM Tire Speed Rating	P (max 93 mph)	P (max 93 mph)	N/A
Tire DOT Safety Code	DOT H3 XXC51	DOT T5XX 030X	N/A
Average Tire Tread Lifespan ²	5 Years or 12,000 miles (20,000 kms) in the Front and Rear Position	5 Years or 12,000 miles (20,000 kms) in the Front and Rear Position	2 Years or 1,600 miles (2,575 kms)
Tire Application Features	Puncture Resistance; Superior Grip on Dry Surfaces; Good Grip on Damp Surfaces	Puncture Resistance; Superior Grip on Dry Surfaces; Good Grip on Damp Surfaces	Soft Terrain; Aggressive, Open-Tread Blocks for Soft, Loamy Conditions; Large Knobs for Maximum Traction

1– ONYX Motorbike must be used in ECO mode on public roads in order to comply with U.S.A. Federal Class 2 Electric Bicycle requirements under Consumer Product Safety Commission (CPSC) Title 15 - COMMERCE AND TRADE CHAPTER 47 - CONSUMER PRODUCT SAFETY, Sec. 2085 - Low-speed electric bicycles (U.S. Public Law 107-319 in 2002; 15 USC 2085, SEC. 38. (b)). Use of any other mode on public roads may be prohibited unless local laws, restrictions, and regulations allow use of other drive modes. ALWAYS CHECK THE LAWS AND REGULATIONS IN THE AREA YOU INTEND TO RIDE BEFORE YOU RIDE THERE.

2– Tire tread wear and lifetime results will vary. Tire lifespan is not covered under ONYX's standard warranty and will vary depending on type and areas of use. Below are various factors that can cause abnormal wear: • Under-inflation/over-loading can cause tread distortion and irregular wear. More seriously they may result in a sudden failure of the carcass due to excessive tire flexing. • High-speed means rapid tread wear, especially due to harder acceleration and extra braking. • Temperature of riding surface – higher temperature causes faster wear • Rough surfaces cause higher abrasion and shorter lifetime of a tire. • Mechanical irregularities such as distorted wheels, incorrect brake adjustment, bad dumpers, excessive tolerance in frame-wheel bearings can also cause severe wear. • Unbalanced rotating weight (heavy spots on rim) can cause irregular tread wear.

FASTENER LOCATION



RCR MODEL

Handlebar Clamp

Triple Tree Bolts

Front Brake Plate

Front Axle Nut

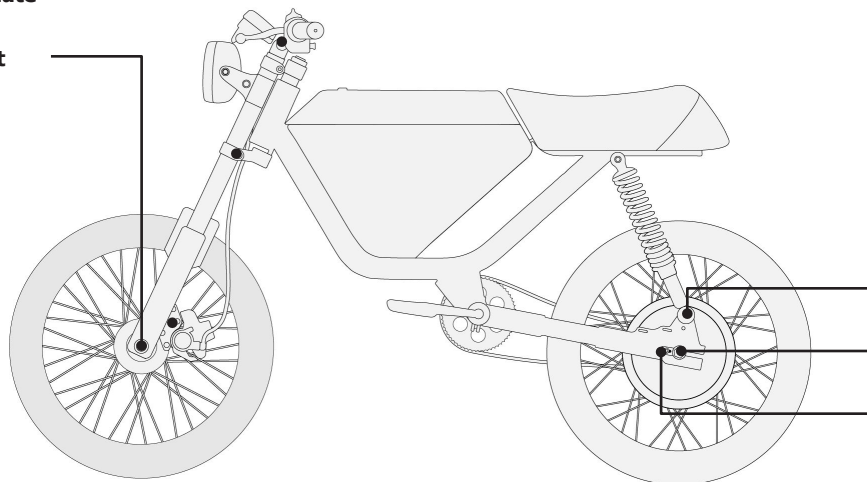

**Lower Shock Mount
Rear Axle Nut**

Rear Axle

Stay

TORQUE SPECIFICATIONS

It's good practice to periodically check over your bike for loose nuts. Below is a table of torque specifications for various fasteners on your bike.

FASTENER	TORQUE	NOTES
Handlebar Clamp	20nm	
Triple Tree Bolts	30nm	
Front Brake Plate	30nm	
Front Axle Nut	80nm	272 RED LOCTITE
Lower Shock Mount	30nm	
Rear Axle Nut	90nm	272 RED LOCTITE
Rear Axle Stay	12nm	

2

8



RCR MODEL

OPTIONAL EQUIPMENT TECH SPECS

As we are constantly upgrading our optional equipment, we don't have specifications for optional equipment at this time.



ACCESSORIES SPECS

As we are constantly evolving and upgrading our accessories, we don't have currently specifications on accessories products. However, if you are ordering accessories, most vintage Puch and Yamaha parts will fit our bikes.

Note threads for ONYX RCR mirror mounts.

Left side: None

Right side: M10, reverse pitch thread

3

0



RCR MODEL

TYPICAL RCR MODEL DISTANCE RANGE

The battery gives the bikes an expected range of between 20-75 miles on a single charge for the ONYX RCR Model (15- 40 miles for the CTY Model) depending on the mode you use, the amount of pedaling you do, the terrain, and your size/ weight. All of these things affect your overall range. For example, only using the throttle consumes the most battery power, but you can help increase your range by pedaling whenever possible to conserve battery power. As a basic reference, take a look at the graphic below to get an idea about how far you can go on a single charge with the 72 Volt RCR Model:

75 MILESECO MODE
MAX SPEED = 20
MPH**40 MILES**NRM MODE
MAX SPEED = ~38
MPHV**20 MILES**SPT MODE
MAX SPEED = ~60
MPH**NOTE**

The throttle-only estimates are based on a 170 pound rider riding a standard RCR model on flat paved roads with nominal stops and starts with no pedaling assistance.

PHYSICAL DIMENSIONS

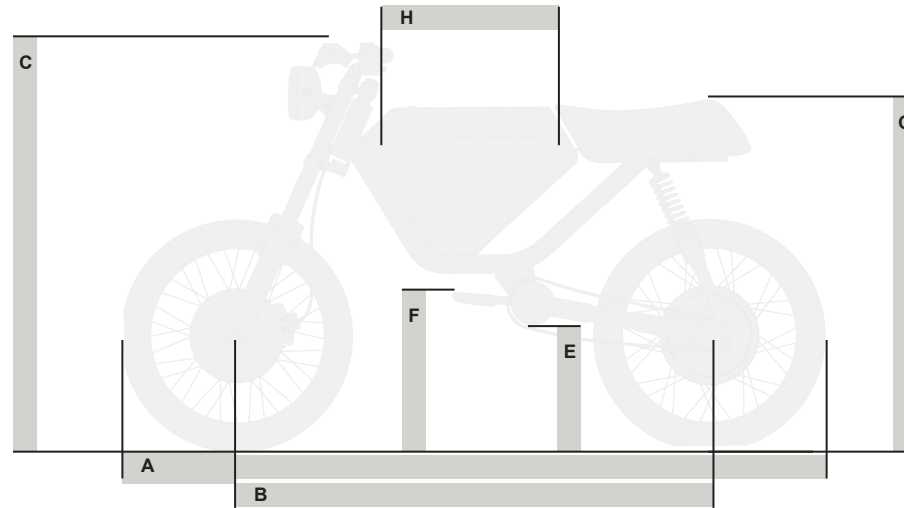

Fig.
3.2

	SPECIFICATION	MEASUREMENT STANDARD RCR SUSPENSION	MEASUREMENT "SHORTY" RCR SUSPENSION
A	Overall Length	68"	68"
B	Wheelbase – Center to Center	44.5"	44.5"
C	Overall Height – from Ground to Top of Display	39.25"	37.25"
Not shown	Handlebar Width – Brake Lever Tip to Tip (Grip End to Grip End)	27" (25")	27" (25")
E	Ground Clearance – Ground to Bottom of Chain Ring	10.5"	8.5"
F	Pedal Shaft Clearance – Ground to Center of Shaft	13.5"	11.5"
G	Seat Height – Ground to Top of Seat	32"	30"
H	Handlebar Reach Distance – from End of Seat to Grips	15"	15"



OPERATING CONTROLS

RCR MODEL FEATURES OVERVIEW

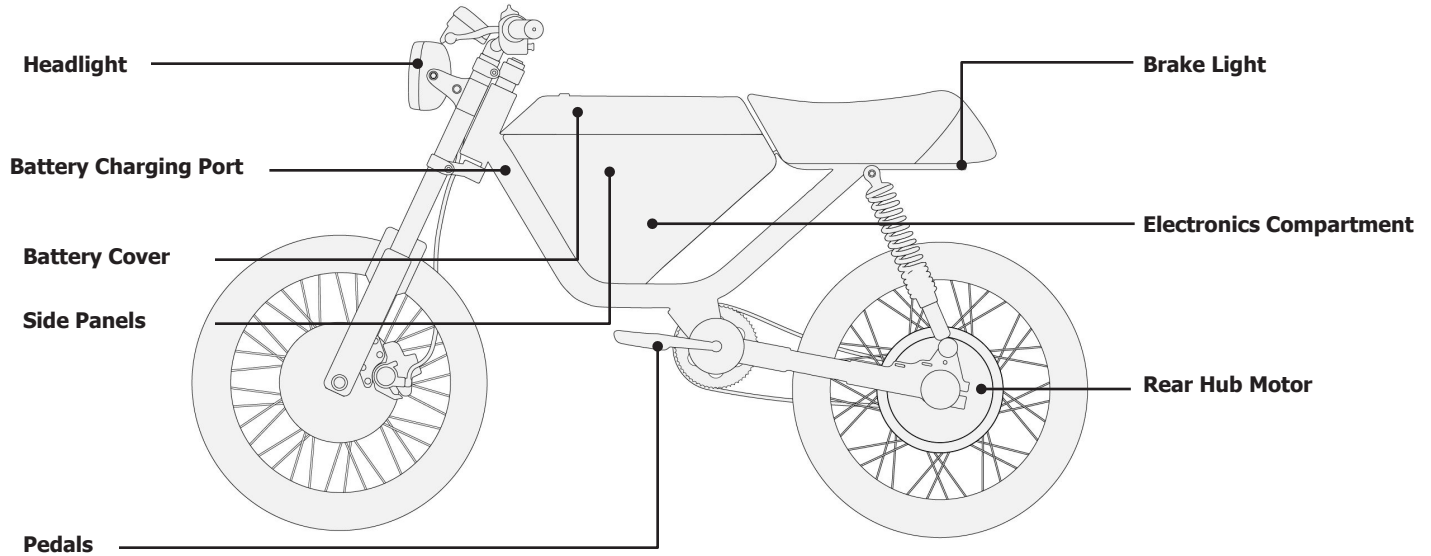

HEADLIGHT

The daytime halo running light is always on for safety and visibility. The switch for the High Beam switch is located on the left side controls and the indicator light illuminates in blue on the Dashboard.

(See Handlebar Control Overview, Page 34 and LCD Dash Overview, Page 35)

TAIL LIGHT/BRAKE LIGHT

The tail light is always on for safety and visibility. The brake light is activated with the two brake levers on the controls.

(See Handlebar Control Overview, Page 34)

PEDALS

Pedals are connect to the rear axle via a single gear and chain.

BATTERY COVER

Remove the battery cover to remove the battery for charging or transportation.

(See Battery and Charger Overview, Page 40)

SIDE PANELS

Remove the side panels to access the electronics compartment. Side panels are made from anodized aluminum and come in silver and black.

REAR HUB MOTOR

3000W electric direct-drive hub motor.

(See General Vehicle Information, Page 18)

ELECTRONICS COMPARTMENT

This compartment houses the speed controller, phase wire connections, wiring harness and other electronic components.



RCR MODEL

HANDLEBAR CONTROL OVERVIEW

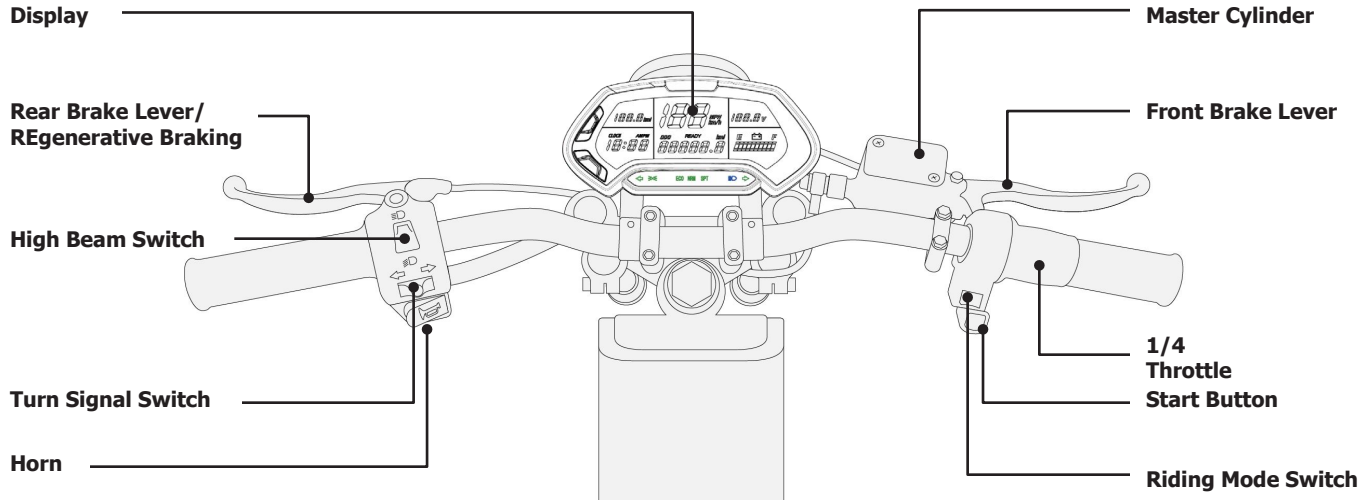

Fig.
4.2

PRO TIP

GO FARTHER BY BRAKING

The key to going farther is using regenerative braking system, or the rear brake. When able to brake safely try using regen braking only to recharge the battery while you are riding. If you are an absolute beast you can try holding the regen brake and pedal at the same time to attempt to charge the bike. Good Luck! ;)

LCD DASH DISPLAY OVERVIEW

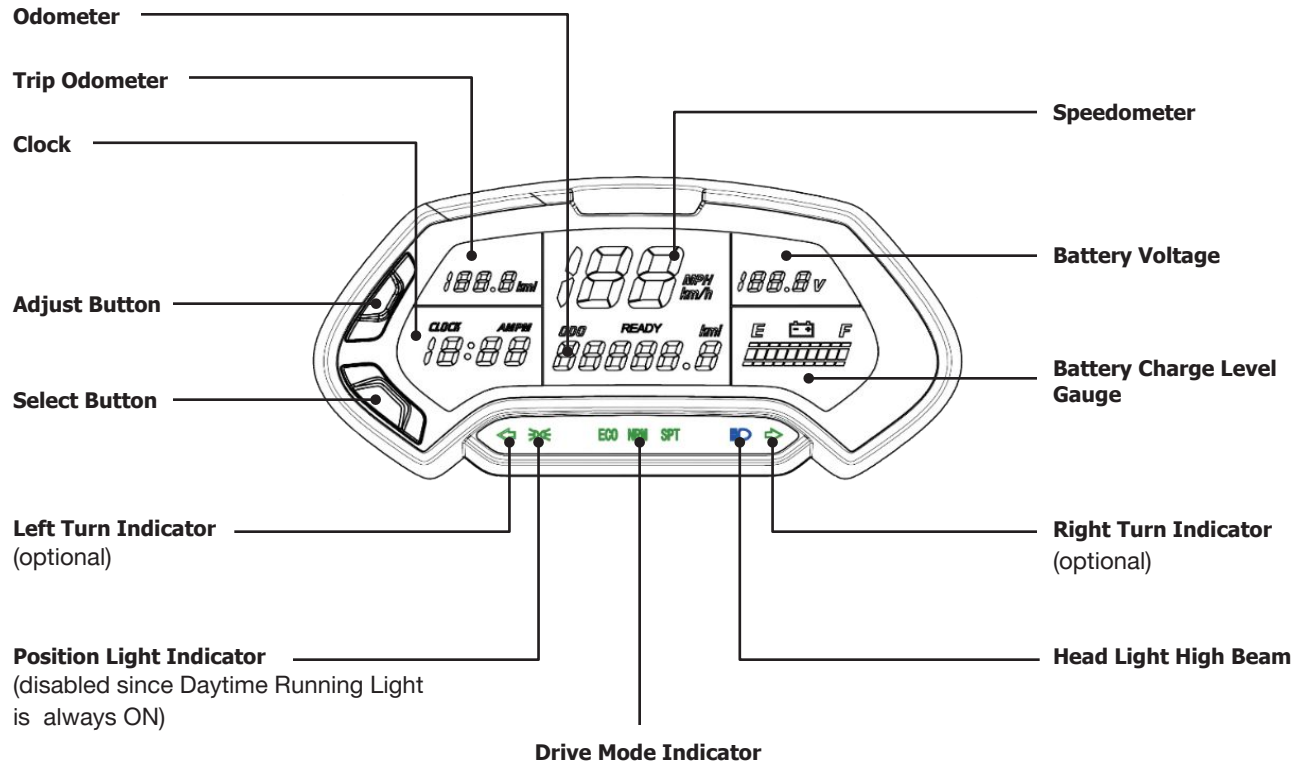
Fig.
4.3

3

6



RCR MODEL

LEFT SIDE CONTROLS

REAR REGENERATIVE BRAKE

The left brake lever not only controls the rear mechanical brake, but it also controls the regen braking. To activate regen braking you only need to depress the lever slightly to activate the switch. Regen is very effective in not only stopping the bike but also recharging the battery. If you are able to use the regen brake to safely stop the bike every time you can dramatically increase your range. The sensitivity of this braking will be fully adjustable in the upcoming mobile application. Warning: regenerative braking should not be used as a reliable means of stopping the bike. While it works almost every time regen braking can stop working suddenly especially if the battery is near a full charge because there is nowhere for the energy to go. Also when applying regen your throttle will be killed. So when you release the regen brake lever make sure you are not giving the throttle any power. For these reasons always use regen braking with extreme

caution.

HEADLIGHT SWITCH

To control the headlight you simply toggle the light switch up on the left hand control to activate the bright LED projector beam. The running lights are always on for safety and only use 0.1v in 5 hours of use. The high beam headlight does use more volts and will drain the battery slightly faster so only use when needed. Note that because the headlight is very bright, make sure you adjust the light so that it is not angled up and obstructing other driver's vision. (Fig. 4.2)

HORN BUTTON

The horn button is located on the left hand controls and to activate the horn you simply press the button. (Fig. 4.2)

BLINKER SWITCH

Each bike is outfitted with a blinker switch for those who would like to add blinkers. To add blinkers you will need to locate the blinker plug behind the left side panel and add your blinker relay/LED blinkers. Note: You must only use 12v LED blinkers. (Fig. 4.2)



RIGHT SIDE CONTROLS

THROTTLE ON/OFF SWITCH (KILL SWITCH)

In total there are three ways to turn off the bike the only way to completely turn off the bike is to turn off the battery or disconnect it from the bike. The kill switch allows the user to quickly turn off the bike by the push of a button on the throttle. This does not deactivate the system like the unlock button does on the key-fob. Only use this button to temporarily turn off power to the throttle. Never store or transport the bike only using this button to kill the power. (Fig. 4.2)

HALF-TWIST THROTTLE

A quarter twist throttle is used to help save energy by encouraging you to rest your hand and coast. Warning: the throttle is extremely sensitive. (Fig. 4.2)

DRIVE MODE SWITCH (3 MODES)

Each bike is outfitted with a three speed function switch. This allows you to toggle through the software limited modes of ECO / NORM / SPRT. Each mode can be adjusted to meet your needs via the soon-to-be-released mobile application. To activate each mode effectively you should not be moving. Otherwise to work properly you must bring the bike's speed below the mode's threshold. Toggle from left to right starting with ECO to get a feel for each mode. Note NORM

and SPRT mode are for off-road use only. (Fig. 4.2 + 4.3)

FRONT BRAKE MASTER CYLINDER AND LEVER

The brake control levers are mounted on the handlebar. Right (2) lever controls the front wheel brake.

3

8



RCR MODEL

KEY-FOB BUTTON LAYOUT

POWER ON / OFF / ARM

Each bike comes equipped with two key fob remotes that can turn on and off the main power to standby, and set the alarm. Note this does not fully kill the power to the system which allows for the alarm and clock to function. Once the battery is removed or turned off you will need to first turn the battery back on for the following to work correctly again.

TURN OFF ALARM + POWER ON

1: Press the Unlock button twice on the key fob and two audible chirps should sound to confirm you

have activated the system. (C)

2: Press the Bolt button twice to turn on the system and listen for one chirp. The dash, and running lights should illuminate immediately following this step so long as the throttle power button is in the ON position. (D)

(See Right Side Controls - Throttle On / Off)

POWER OFF TO STANDBY (LOCKED BUT NOT ARMED)

1: Press the Unlock button twice on the key fob and a audible chirp should sound to confirm you have deactivated the system. The dash, and running lights should turn off following this step if your power button is in the on position. (C)

ARMING THE ALARM

1: Make sure you have followed the steps to power off the system to standby.

2: Make sure your power button on your throttle is in the off position.

3: Press the Lock button once to arm the alarm. (A)



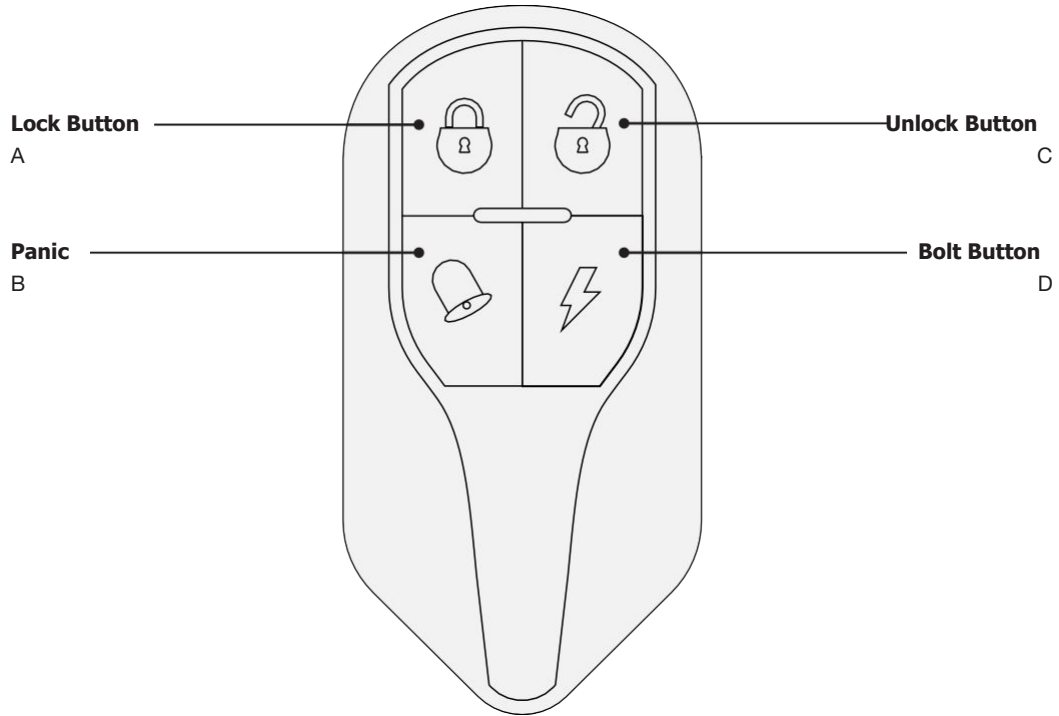

OPTIONAL ACCESSORIES OVERVIEW

TURN INDICATOR LIGHTS



RCR MODEL

FRONT FORK GAITERS

HEADLIGHT GRILL

FRONT FENDER

REAR FENDER WITH INTEGRATED BRAKE LIGHT

REAR RACK



OPERATING INSTRUCTIONS

GENERAL OPERATION

1. Prop the bike on its kickstand.
2. Remove the wood cover to turn on the battery then replace the cover.
(SEE BATTERY COVER REMOVAL section)
3. Use the key-fob to activate the bike's power.
4. Press the kill switch on the throttle to power up the system.

THROTTLE

The speed of the bike is controlled with a twist grip on the right side of the handlebar. To accelerate twist the throttle towards you very slowly; to decelerate release slowly. Read the Pro-Tip in this section about staying above 60 volts (56 volts with the 41

Ah) when you throttle.

BRAKING

To slow down, release the throttle control and apply equal pull to both brake levers. Application of both brakes at the same time is essential to prevent premature brake wear and/or loss of vehicle control.

CAUTION: Be alert when riding on wet or sandy surfaces. Loss of traction between tire and road can occur under these conditions. Be careful when braking, turning, or accelerating under adverse conditions.

STOP AND PARK

Switch off bike with the kill switch. Turn off the bike with the key-fob. Rest the bike on the kickstand and set the alarm. It is highly recommended to lock the bike with lock and use a front disc brake lock for added security. A high security locking device is recommended along with a GPS tracking device such as a TILE.

PRO TIP

STAY ABOVE 60 VOLTS!

When riding you will notice the voltage drop as you pull the throttle. The amount of voltage drop is also known as voltage sag. This is normal and should be noted that this is the best way to gauge how much energy you have left.

The battery is programmed (BMS) to cut out at 60V to protect the battery. If you depend only on the battery level meter you will find yourself out of juice before you realize it. This is due to the fact that battery level meters are great for at-a-glance info, but never give you accurate data to really gauge the distance you can go with the energy available. So the key to getting back home is to never let the voltage drop below 60 volts while you are pulling the throttle. If it does the BMS will kick in and kill the power.

BATTERY OVERVIEW

RCR MODEL

23AH BATTERY (STANDARD) BATTERY TECHNICAL SPECIFICATIONS**BATTERY TECHNICAL SPECIFICATIONS**

ITEM	SPECIFICATION
Charge Capacity	23 Ah
Battery Weight	25lbs
Battery Dimensions	14" long x 3" wide x 5" tall
Battery Cell Components	NCR18650PF 2900mAh 10A cells
Battery Cells	Customized 20S8P Lithium battery pack
Voltage Cut Off	The BMS is programmed to turn the battery off for protection at 60 volts (56 for the 41ah)
Recommended Voltage Charge Rate	Recommended voltage charge and discharge range is between 84 volts and 60 volts (56 for the 41 ah)

BATTERY CELL TECHNICAL INFORMATION

Each battery cell will only retain 80% of its capacity if stored for a month at 4 degrees Fahrenheit or 122 degrees Fahrenheit.
Each battery cell is designed to be charged between 32 degrees Fahrenheit or 113 degrees Fahrenheit.
Each battery cell can be charged as high as 1.35 volts and 1.50 volts.
Each battery cell does not need to be charged continuously beyond 20 hours for a total of 400 hours.

BATTERY PERFORMANCE

Getting the maximum performance out of the Onyx RCR requires taking great care of its battery. Understanding that the bike and the battery are two separate things goes a long way. There are four things to understand about the Onyx RCR battery which also applies to a EUC, eBoard, eScooter, and other eBikes.

- Balancing the battery pack is an absolute must.
- No identical lithium battery packs are the same.
- There will generally be a 3% percent difference between identical battery packs.
- Lithium battery packs perform differently at 100% charge and 50% charge.

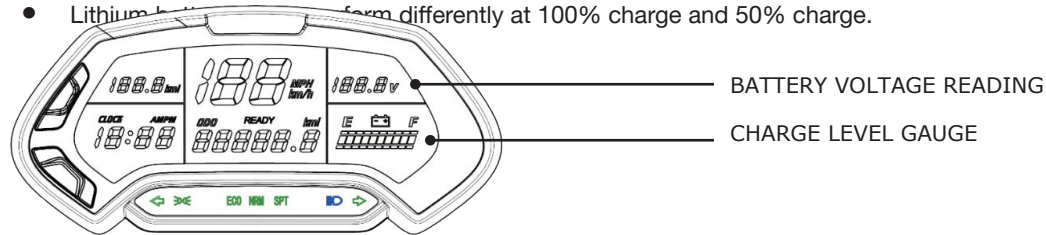

The Onyx RCR draws 0.6 volts while it is turned on.

	DISPLAY VOLTAGES	ACTUAL BATTERY VOLTAGES
100% Charge	83.4 Volts	84.0 Volts
75% Charge	77.8 Volts	78.4 Volts
50% Charge	73.2 Volts	73.8 Volts
25% Charge	70.2 Volts	70.8 Volts
0% Charge	59.4 Volts	60.0 Volts

**BATTERY SAG**

Become familiar with the amount of battery sag full throttle causes in eco mode, normal mode, and sports mode. Sag is described as the amount of electricity drawn depending on how much throttle is given. On a colder day it is not uncommon at full throttle for the voltage sag to be 7 volts and on warmer days for it to be between 4 volts to 5 volts.

- Each mode limits the amount of sag.
- Eco mode will help prevent cut offs by reducing the sag amount.
- The amount of throttle given directly controls the amount of sag.

BATTERY CUT OFF

When the amount of battery sag falls below 59 volts (56 for the 41 Ah), the Onyx RCR will turn off. Cut off occurs because the battery management system is programmed to protect the batteries from damage from low voltage.

If you have a 23 Ah battery and you batter cuts out you will need to toggle the switch on the battery case and disarm the alarm. If you have the 41 Ah batter your battery will automatically turn back on after 30 seconds.

LOW BATTERY LEVELS

The Onyx RCR battery does not discharge in a straight constant line, it is more like a curve where the top of the charge above 85% (80.4 volts) and the charge below 15% (68.8 volts [64.4 volts for the 41ah]) deplete faster. The entire 84 volts are available but spread out and discharged at a different rate towards the top of the charge and bottom of the charge.

The 23 Ah battery will cut out at 59 volts. The 41 Ah battery will cut out at 56 volts. If the battery is unbalanced, it can cut out at 67 volts (resting) or below, depending on the degree in different voltages between the individual cells.

BATTERY DISCHARGE CURVE

The Onyx RCR battery management system is programmed from 4.20 volts (84.0 volts) to 3.00 volts (60 volts). The benefits of this voltage range are a better battery cycle life by not discharging lower than 3.00 volts and it's safer to not charge above 4.20 volts. Nominal voltage is where most of the battery's capacity is stored, between 3.6 volts (72 volts) and 3.695 volts (73.9 volts).

	LOW VOLTAGE DISCHARGE CURVE
6% Charge	65.8 Volts
4% Charge	64.4 Volts
2% Charge	62.0 Volts
0% Charge	60.0 Volts

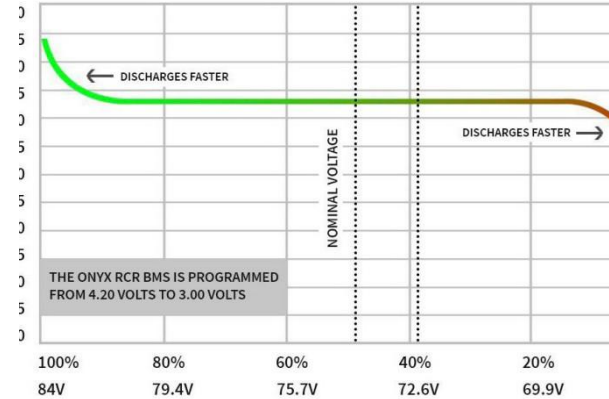
ONYX RCR BATTERY 23AH DISCHARGE CURVE**PRO TIP
S**

- + Riding faster consumes more battery.
- + Become familiar with how many miles away your destination is going to be.
- + Not balancing the individual battery cells makes for a not so great battery.
- + Keep your battery charge levels above 20 percent which is 69.9 volts on the display voltmeter.
- + How well the battery is taken care of directly impacts the Onyx RCR's performance, battery sag, and top speed.

BATTERY COVER, REMOVAL, AND REINSTALL



RCR MODEL

The battery cover is made of rosewood veneer, pressure-formed plywood and should be handled with extreme care. Below are the steps for proper removal of the cover so you do not break the cover. Never force, pry, or hit the cover or you could cause major damage to the wood.

1: Unlock the cover gently slide the wood cover backwards towards the seat.

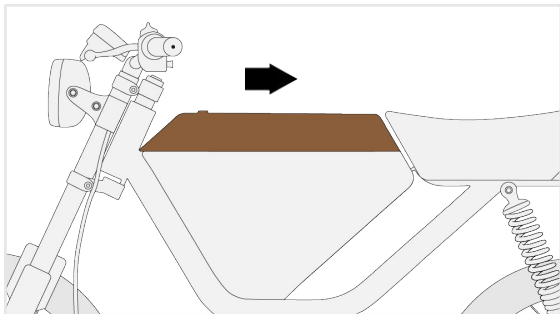

2: Now slide the cover as far forward as possible to be able to lift the back of the cover off the bike.

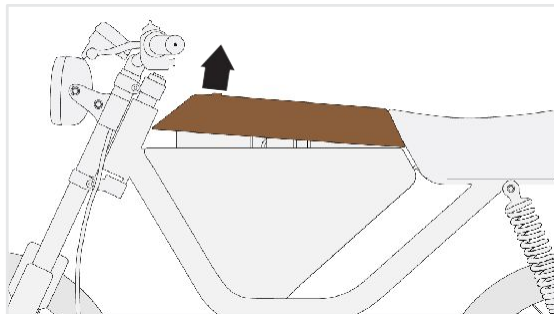

PRO TIP

- + Keep one of the duplicate keys and key-fob in a safe place so you do not lose all your keys at once.
- + Do not re-adjust the seat forward or there will be no room for the wood cover to slide backwards.

3: Lift the front of the cover over the top of the fork's head tube nut.

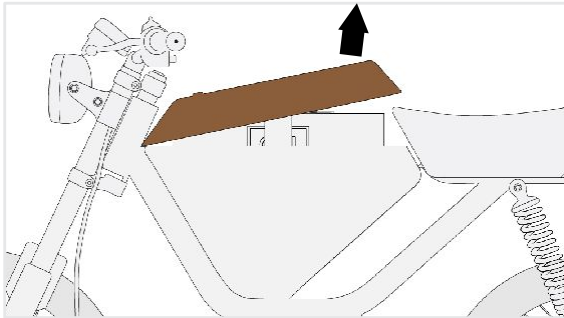

4: Unlatch the battery strap and gently place the buckles on the sides of the bike. Reverse these steps to install the battery.

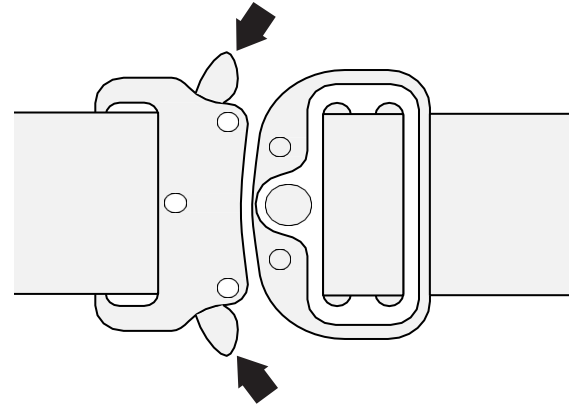



BATTERY REMOVAL

Removing the battery is very easy but you need to take extreme caution when doing anything related to the battery. Below are the steps to safely remove the battery for charging it off the bike.

1: Turn off the battery with the battery switch to the “OFF” position. **Never attempt to unplug the battery with the battery switch in the “ON”**

position. Once off unplug the battery
Not a 4Ah battery is turned ON/OFF via the
 bluetooth-enabled ONYX BMS App.

2: Unlatch the battery strap and gently place the buckles on the sides of the bike.

3: To fully remove the battery grab the battery case handle and lift out the front of the battery first until it clears the top of the bike. In the meantime make sure to gently help the battery cables out of the bike.

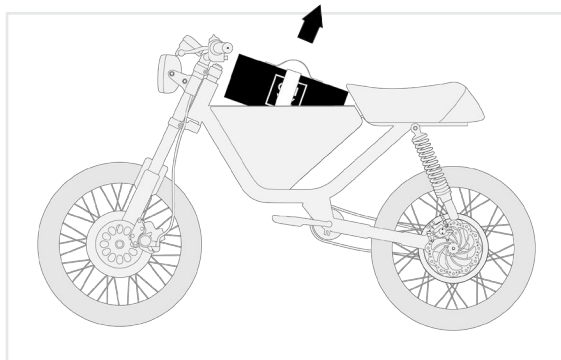
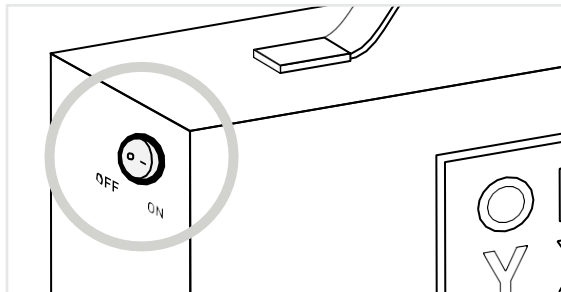

BATTERY INSTALLATION

Follow the installation steps below with extreme care.

1: Always make sure the battery switch is in the “OFF” position before installing the battery. Place the back end of the battery on the battery tray first then let down the front gently moving the cables into the bike.

2: Plug in the red battery discharge cables. Do not be alarmed if you forgot to turn off the battery and the connectors spark on contact. This is okay a few times but over time you can wear out your connector.

3: Grab both ends of the battery strap and buckle it back together snugly (adjust for fit if necessary). Once the battery is secure you can turn the battery power to the “ON” position. For reinstallation, reverse steps 1-4 of BATTERY COVER + BATTERY REMOVAL on the previous pages.

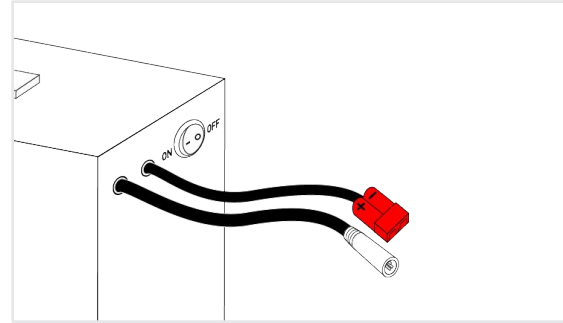



BATTERY CHARGING

CHARGING DON'TS

- Don't leave the battery fully charged (84.0 volts – 83.4 volts on display) when not riding.
- Don't charge immediately after riding. Wait for the battery to cool. Charge an hour after.
- Don't discharge the battery below 15% (68.8 volts – 68.2 volts on display) to keep it healthier.
- Don't charge the battery where it can be exposed to temperatures below 32° F or above 120° F.
- Don't turn off the battery power switch when charging.
- Leaving the battery fully charged to 100% (84.0 volts – 83.4 volts on display) when not riding for a day or two is okay but don't make a habit of it. This also includes charged to 97% (83.3 volts – 82.7 volts on display).

CHARGING DOS

- Once a month balance charge the battery to maintain its health.
- Between rides, leave the battery charged at 88% (81.1 volts – 80.5 volts on display).
- One hour before riding, charge battery to 97% (83.3 volts – 82.7 volts on display).
- When not riding for long periods, store the battery at 50% (74 volts – 73.4 volts on display).
- Occasionally use contact cleaner to clean the charger XLR cable ports and battery XLR cable ports.

See *Battery Maintenance + Safety Tips*, page 60

CONSTANT VOLTAGE CHARGING

When the Onyx RCR charger (5 Amps) light turns green that means 97% (83.3 volts) of the charge is complete. The remaining 3% to charge to 100% (84.0 volts) takes 95 more minutes after the charger light turns green. This last 3% is called “constant voltage” and is done through trickle charging.

It is okay to charge (5 Amps) the Onyx RCR to 97% (83.3 volts) (charger light turns green) and go for a ride. But this means that when your battery gets below 68 volts, it may cut out sooner.

BATTERY POWER SWITCH

The power switch located on the battery itself should remain in the “on” position when charging the battery. Not to be mistaken with the power switch located next to the throttle. The alarm fob power options play no role in charging. The battery power switch controls the state of the battery management system (BMS) inside the battery. Turning off the battery power switch turns off the battery management system (BMS).

Use the battery power switch when storing the battery or when not using the bike for more than two weeks. When the battery power switch is in the “on” position and the bike is turned off from either the throttle power switch or the alarm fob, the bike draws 0.2 volts. Over time this will drain the battery down.

CHARGING PREFERENCES

Depending on the desired use or needs of different riding styles, there is a balanced charging method that works for everyone.

As an example, it’s okay to keep the charger plugged in all the time and maintain a constant 84 volts full charge. Although this will reduce the charge cycles of the battery to 800 or less, after which about 85% of the total battery capacity will be available. Battery sag will increase by 15%, and cut-offs will happen sooner around 65 volts. Keeping in mind that all batteries are supposed to be replaced over time.

Increasing the charge cycles (*See Battery Charger, page 54*) with the stock charger will fit with the majority of the Onyx RCR owner’s use of the bike. In turn, providing a cleaner flow of electrons between the anode and cathode through the electrolyte, which extends the life of the battery, reduces sag, and lowers cut off voltage in the long run.

5

4



RCR MODEL

BATTERY CHARGER

CHARGING WITH THE STOCK CHARGER

The normal charging process with the Onyx RCR stock charger is to unplug the charger when the charger light turns green, which only charges the battery to 97% (83.3 volts). This, in turn, is slightly less stressful on the battery cells than being charged to 100% (84.0 volts). Being charged to 97% (83.3 volts) is good for about 800-1000 charge cycles.

If the indicator light is not lit at all, it is possible that the charger's replaceable fuse may be blown and needs to be changed. Do NOT open the charger case for any reason. Fuses are easily replaced without opening the charger case.

CHARGE CYCLE BENEFIT

Increasing the charge cycles also means that the electrolyte that is between the anode and cathode will be healthier for the electrons to pass through. Which means better current draw, lower sag levels, and lower cut off levels.

INCREASE CHARGE CYCLES WITH THE STOCK CHARGER

Increase the charge cycles from 800 to 1500 with the stock Onyx RCR charger by following the method below.

- When not riding, maintain the battery charged to 80.4 volts (82%) on the display by unplugging the charger when the charge reaches approximately 80.4 volts.
- Full charge for 87 minutes (one and a half hours) before riding to go from 80.4 volts (82%) to 83.3 volts (97%) then unplug the charger when the charger light turns green.

DOUBLING CHARGE CYCLES

Charging the Onyx RCR battery every day to 100% would still add up to over 3 years of good use. Whereas most Onyx RCR owners will not be charging their battery every day of the month. A Grin Tech Cycle Satiator charger can be programmed to charge the Onyx RCR battery to 50% to more than quadruple the charge cycles or 85% to more than double the charge cycles.

CHARGER MAINTENANCE**CLEAN XLR CONTACTS**

Cleaning the XLR charger pins and XLR battery cable porthole reduces electrical resistance. Electrical resistance makes for an inefficient connection and generates heat.

To clean the XLR charger pins and XLR battery portholes, remove the cotton from one end of a cotton swab, place two drops of contact cleaner on each end of the cotton swab. The end of the cotton swab without the cotton gets inserted into the portholes of the charger XLR cable while twisting. The side of the cotton swab that is bare will slide into the battery XLR cable portholes. The end of the cotton swab with the cotton is used to clean the contacts of the chargers XLR pins.

[DeocIT Battery Terminal Contact Cleaner](#)

5

BATTERY BALANCING

6



RCR MODEL

Battery balancing refers to techniques to improve the available capacity of the battery and/or increase the battery's capacity and keep the battery safe. Variations in battery cells come from a number of factors including cell age, environmental exposure, impurities.

Unbalanced batteries when fully charged (charger light green) will show on the display between 81.6 volts and 82.8 volts.

BATTERY CHARGING SAFETY

Overnight charging and consecutive balancing are safe to do as the Onyx RCR stock charger and onboard battery management system provide redundant fail-safe mechanisms. As the battery charge level (5 amps) arrives at 97% (83.3 volts) the charger will reduce its amperage output substantially lower and begin trickle charging. In turn, reducing its heat output and shutting off its cooling fan for the remainder of the charging, trickle charging, and also during the battery balancing.

NEW BATTERY BALANCING

Battery balancing is available on the Onyx RCR although it is not available on most e-bikes. Battery balancing serves the purpose of equalizing the voltage between all 160 individual battery cells inside the Onyx RCR battery. When a battery is balanced, 100% of its capacity is available, whereas an unbalanced battery provides less than 100% of its capacity and causes premature battery degradation. Balancing can be done every so often, once a month, or more often depending on the use of the bike.

CONSTANT VOLTAGE CHARGING (see *Battery Charging*, page 53)

Constant voltage charging (trickle charging) is not the same as battery balancing. When the Onyx RCR charger (5 amps) reaches 97% (83.3 volts) (green light on the charger) the remaining 3% to reach 100% (84.0 volts) takes 95 more minutes. This last 3% of the charging is called “constant voltage” and is done through trickle charging, which is why it takes longer. Battery balancing occurs after the “constant voltage” portion of charging the battery.

5

8



RCR MODEL

BATTERY MANAGEMENT SYSTEM

The Onyx RCR battery management system which is contained inside the battery requires that the charger be plugged in for it to balance individual cells even if the battery is fully charged. The Onyx RCR battery is comprised of 160 NCR18650PF 2900mAh 10amp 18560 batteries.

The Onyx BMS (battery management system) is programmed to maintain the individual batteries between 4.20 volts charged to 3.00 volts depleted. Although individual 18650 batteries can be charged as high as 4.25 volts and as low as

2.50 volts, it is healthier for the batteries in terms of charge cycles and safer to keep batteries between 4.20 volts and 3.00 volts. During riding, the BMS monitors the voltage of the battery pack as a whole and that of the individual battery groups. One of the functions of the BMS is to protect the batteries from undercharging. If the BMS detects any individual battery(s) that have depleted closer to 3.00 volts (60 volts) before all the other batteries, it will cut off the battery to protect the lower unbalanced depleted battery(s) from undercharging below 3.00 volts.

USAGE CHARGE SCENARIOS**SEASONAL RIDER**

Store battery at 50% charge (73.9 volts) when not riding.

Before riding full charge balance battery for 3 days straight and cycle battery switch each of the 3 days.

OCCASIONAL RIDER

Once a month charge for 3 days straight and cycle battery power switch each of the 3 days balancing.

MORE OFTEN RIDER

Twice a month charge for 3 days straight and cycle battery power switch each of the 3 days balancing.

DAILY COMMUTER

Leave charger plugged in every day and cycle battery switch 3 times a week.



RCR MODEL

BATTERY SAFETY + MAINTENANCE TIPS

Maintaining and caring for your battery will help prolong it's life while promoting safe and efficient use.

Below are some tips for keeping a healthy battery.

Safe Battery Temperature Ranges

OPERATING -20°C — 50° C

CHARGING 0° — 45° C

STORAGE 0° — 60°C

Temperatures over 100°C will sacrifice the life of the battery. It will burn or explode at temperatures over 140°C.

+ Never leave your battery on the charger after it is done charging. Although the battery charger does have a cut off this is good practice to keep your battery safe.

+ Only use the provided charger. Use of after-market high-speed chargers is at your own risk.

+ Avoid constant exposure to extreme temperatures for a long battery life.

+ Always unplug the battery when working on the bike.

+ Always charge your battery before use after sitting for a few days

+ Long term storage should be stored at 50% charged at room temperature. Never store the battery on empty.

+ Avoid fully discharging your battery frequently to prolong the life of the cells.

+ Keep the bike off while charging the battery in the bike. You can turn the bike on to check the battery charging progress but do not leave the bike on.

+ Do not drop the battery.

+ Do not use a damaged battery.

BATTERY STORAGE

STORING THE ONYX RCR BATTERY

When storing the Onyx RCR battery, charge it to 50% (73.2 Volts) and turn the switch on the battery to the off position. Lithium batteries are under the most strain when they're fully charged or completely discharged. At 50% charge, this means that half of its moveable lithium ions are in the lithium cobalt oxide layer and the other half are in the graphite layer. At 50% charge, the battery is under the least possible strain.

BATTERY TEMPERATURES

- **DO NOT STORE THE BATTERY WHERE IT WILL GET ABOVE 120 DEGREES FAHRENHEIT.**
- It's preferable to not store the battery outdoors when temperatures drop below 32 degrees Fahrenheit.
- Lithium battery cells generate a small amount of safe heat when a large demand is put on them, which adds up to 5 degrees inside the Onyx RCR battery pack.
- When the temperature outside is below 45 degrees Fahrenheit, allow the battery to rest for an hour after riding before charging it, allowing it to get closer to room temperature.



MAINTENANCE

GENERAL MAINTENANCE + SERVICE

OWNER RESPONSIBILITIES

Take care of your ONYX Motorbike, and it will take care of you! Provide routine care for your ONYX bike as detailed in this chapter. The owner is responsible for learning and obeying all federal, state, regional, and local laws regulating the operation and maintenance of an electric bike.

SERVICE SHOP CONSIDERATIONS

If these procedures outlined in the maintenance and service schedule are beyond your ability, bring your bike back to either ONYX shop for regular maintenance. If there is no shop in your area, we recommend calling ONYX Tech Support: (310) 800-2531

Be sure that whoever services your bike completes the maintenance record and save all service documents should you transfer this vehicle to another owner. Additionally, service records can help advise our technicians about your vehicle's history.

RECOMMENDED MAINTENANCE + SERVICE SCHEDULE

SERVICE	EVERY RIDE	1 MONTH (or 30 HOURS)	6 MONTHS (or 100 HOURS)	12 MONTHS (or 200 HOURS)	24 MONTHS (or 400 HOURS)
Check the Headlight, Tail Light for Proper Operation	V				
Check Tire Pressure (32 psi F&R)	V				
Check Front Brake & Adjust	V	V	V	V	V
Check Rear Brake & Adjust	V	V	V	V	V
Check Battery Charge Level	V				
Check & Torque Fork, Axle, Handlebar, and Suspension Nuts <i>(SEE RCR TORQUE SPECS TABLE, page 53)</i>	V	V	V	V	V
Wipe Down & Dry Frame & Rest of Bike Parts Using a Soft Cloth	V				
Carefully Check Tires for Any Debris or Wobble	V				
Check Front Brake Fluid Level (DOT3)		V	V	V	V
Check Battery Strap to Make Sure Battery Is Secure	V	V			
Lube and Tension Bicycle Chain		V	V	V	V
Check Rear Wheel & Motor Alignment		V			
Lube Rear Brake Cable			V	V	V
Inspect and Clean Frame			V	V	V
Check Hub Motor Cable and Clearance			V	V	V
Lube All Moving Parts and Bearings			V	V	V
Check Battery Connections				V	V
Change Key Fob Battery				V	V
Check Tire Thread Depth				V	V
Change Front Brake Fluid (DOT3)					V
Change Front and Rear Brake Pads					V
Check Wheel Trueness					V



RCR MODEL

BASIC MAINTENANCE

CLEANING

Regularly clean and lubricate all moving parts, tight- en nuts/bolts, and adjust as required. This includes all steering parts, bicycle pedals, suspension, and wheel parts.

(See *General Information > RCR Torque Specifications, page 27*)

PARTS + FAIRINGS SERVICE

REMOVING SIDE BODY PANELS

REMOVING THE SEAT

REMOVING THE HANDLEBARS

REPLACING BATTERY COVER LOCK

CHECK YOUR NUTS + BOLTS

With any moving vehicle it is good practice to always check your hardware before you ride. You can do a visual by doing a full walk around the bike before every ride and you should do a physical check after every couple rides to make sure nothing is vibrating loose. Most bikes that encounter rough terrain will need attention more frequently.

CHECK YOUR ELECTRICAL

CHECK THE CONDITIONS OF YOUR WIRES

Inspect all wires for sheathing wear and loose connections.

ALARM KEY FOB BATTERY REPLACEMENT

Using a fine tip flat head screw driver pop the two chrome sides off, starting from the top of the remote. When those are off starting from the bottom work your way around the outside and the calm shell will open. The fob takes a CR2032 battery.

BATTERY AND CHARGER MAINTENANCE

See *OPERATING INSTRUCTIONS > BATTERY CHARGING, page 52*)

BATTERY

BATTERY CHARGER

REPLACING THE BATTERY CHARGER FUSE

DETAILED SERVICE GUIDES FOR THE FOLLOWING
CAN BE FOUND ONLINE AT:
WWW.ONYXMOTORBIKES.COM/PAGES/USER-MANUAL



BRAKE SERVICE

FRONT BRAKE

The front brake is hydraulic and requires brake fluid to operate. You should always check to make sure your brake reservoir has enough fluid in it to operate properly or you will eventually lose your ability to stop with the front brake. There is a window on the side of the reservoir that tells you how much fluid is left when you look at it level. If you do not have experience with maintaining hydraulic brakes have a professional refill or bleed the brakes for you when needed. Never attempt to ride with leaks or damaged brake lines.

CHECK BRAKE PADS

CHECK BRAKE FLUID RESERVOIR

REAR BRAKE

Besides replacing the brake pads when needed you should adjust the brake cable when the pads wear down and/or the cable settles during regular use.

CHECK BRAKE PAD

ADJUST BRAKE FOR PERFORMANCE

WHEEL + TIRE SERVICE

SERVICING THE FRONT WHEEL + TIRE

REMOVING THE FRONT WHEEL

REPLACING THE FRONT TIRE + TUBE

INSTALLING THE FRONT WHEEL

SERVICING THE REAR WHEEL + TIRE

REMOVING THE REAR WHEEL

REPLACING THE REAR TIRE + TUBE

INSTALLING THE REAR WHEEL

CHAIN + FREE WHEEL

REPLACING THE BICYCLE CHAIN

Keep your chain and freewheel lubricated regularly to prevent premature wear, and clean your chain after a dirty or salty ride.

LONG TERM STORAGE

Follow best practices for Li-Ion battery maintenance. There is much debate about how to keep your battery lasting a long time so do your research and decide what fits your riding habits best.

REMOVING AND STORING THE BATTERY

See *OPERATING INSTRUCTIONS > BATTERY REMOVAL*, page 50

section for information of battery removal.



TROUBLESHOOTING

ELECTRIC MOTORBIKE PRECAUTIONS

Your ONYX Motorbike has high voltage components. The high voltage used by these components is dangerous and can cause personal injury, severe burns, electric shock and even fatal injury unless appropriate precautions are taken. Always observe and obey the instructions on labels attached to components on the vehicle. They are there for your safety. Do not touch, attempt to remove or replace any high voltage parts, wiring (identified by the orange outer sleeving) or connectors. If the motorcycle is involved in an accident do not touch any high voltage wiring connectors or the components connected to the wiring. If a fire occurs, extinguish visible flame with a Class D power-type fire extinguisher. After flame has extinguished, douse with a water-based fire extinguisher.

(See *SAFETY INFORMATION*, page 16) (See *BATTERY SAFETY TIPS*,

COMMON TROUBLESHOOTING

All our bikes are carefully inspected before shipping. However, even after a bike is inspected, technical issues can occur. Following are some ways to diagnose common issues “should one arise” and get you back on the road again. If you are unable to diagnose and fix the issue on your own, bring the bike by one of our authorized repair shops. If there is no shop in your area, call our customer service support line: (310) 800-2531.

PRO
TIP

DON'T FREAK OUT

It may feel confusing at first...but read carefully, give us a call or send us a request on Zendesk and keep refreshing your browser because we are constantly updating our manual.

GENERAL PERFORMANCE CONCERNS

These are probable issues and diagnostic solutions.

UNRESPONSIVE THROTTLE

1. Likely the left brake lever is stuck, activating the brake light and the regen braking. Regen braking prevents the throttle from allowing a signal to the controller. If the lever is not engaged then check the wires coming from the left lever where the brake light switch is located. Peel back the rubber boot and see if the two connectors are touching. If so reattach the two connectors to the brake light switch on the lever. When the two wires are touching this creates the same result as the lever activating the regen brake making the throttle unresponsive.

2. If the lever brake switch is fully connected then possibly one of the wires inside the bike has worked its way out of a connector. This is very rare but can happen especially if you try working on the electronics inside the bike and tug/move on the harness. To solve this you will need to remove the side panel and reattach any loose wires.

3. You damaged the throttle by accidentally spilling a massive amount of corrosive liquid such as brake fluid on the throttle housing. The only solution here is to purchase a new replacement throttle.

SPEED CONTROLLER ERROR CODES

The speed controller has a green light (no issues) and flashing red light to indicate errors in the controller or motor.

<https://kellycontroller.com/wp-content/uploads/kls-s/KellyKLS-SUserManualV1.10.pdf>

HORN AND/OR RUNNING LIGHTS DO NOT WORK

Check the connectors and see if they have disconnected and need to be reattached.

REAR BRAKE FEELS WEAK

Since the rear brake is a mechanical hybrid caliper using a cable to activate the hydraulic piston, you will need to periodically adjust the cable. If you use the rear brake a lot you will benefit from using the regen braking to save you from

having to do regular adjustments or pad replacements.

FRONT BRAKE FEELS SOFT

Check for leaks or loose banjo bolts on the brake line. If you find any leaks, do not ride the bike and have the front brake serviced by a moped/motorcycle mechanic.



RCR MODEL

CHAIN IS LOOSE OR POPS OFF THE GEARS

The rear wheel might have become loose, allowing the wheel to slide forward and making the chain loose.

REAR FREEWHEEL SPROCKET IS MAKING NOISE

If the rear freewheel is starting to make noise when riding then you need to lube the freewheel. WD40 is okay but you should use a bike lubricant for the freewheel. If you let this get worse the freewheel will eventually fail due to drying out and it could seize.

FRONT FORK FEELS LOOSE WHEN STOPPING

While this is rare it can be very strange when you come to a stop and the bike feels like there is some play in the front- end. This means you need to tighten down the top fork nut right behind the handlebars. For good measure make sure

all the parts are secure and there is no loose hardware.

ADDITIONAL TROUBLESHOOTING RESOURCES

Below are some helpful links to further troubleshoot your bike and gain more knowledge of how your bike functions.

FACEBOOK GROUPS

The ONYX Motorbikes Group on Facebook is a great resource for troubleshooting, mods and community

ONYX Motorbikes Facebook Group:

<https://www.facebook.com/groups/onyxmotorbikes>

**69 ;
)**



TERMS & CONDITIONS

GENERAL INFORMATION

ONYX Motorbikes, a corporation duly organized and validly existing under the laws of the US, hereinafter referred to as ONYX, is a manufacturer and developer of electric motorbikes, components and associated gear.

General terms and conditions are meant to regulate our users at onyxmotorbikes.com. Their validity extends to future transactions with ONYX as well as visits to onyxmotorbikes.com. The right to revise Terms and Conditions remains with ONYX. Users are requested to keep themselves updated with changes by checking the updated dates placed at the end of terms and conditions

onyxmotorbikes.com at times performs and concerns with services mediated by outside organizations. In such cases, ONYX acts as an intermediary therefore not responsible for errors resulting from those organization activities. ONYX is not liable for damages arising from using the site or not. For any damages caused by using the site or for that matter not being able to use the site. Like any business, ONYX can't promise a website free of problems and

some security concerns.

VIOLATION OF RULES

ONYX seeks justice in the event of violation of the terms and conditions. Therefore, persons found guilty of any offense concerning the preserved rights are prosecuted.

Violation of terms and conditions grants ONYX the right to look for law and equitable remedies that may involve restricting the offender's right to access the site. Violating password-protected areas may call for court charges.

ONYX TRADEMARKS

ONYX trademarks include ONYX typo, ONYX logo, ONYX logo + typo and ONYX components. ONYX may sometimes be referred to as 'us' in the Terms and Conditions. Clients are advised to use these materials for personal use but not for commercial purposes. The copyright permission notice is included in the documents, clients may download, print, and store copies of the materials for personal use. No charging, no changing, no publishing, no transmit or distribution without permission from ONYX is allowed. No modification in any way of the material without documented permission from the owner is allowed. Exceptional cases would be in line with the legal notice of no rights or licenses to the article, or any portion thereof shall be granted or implied. You may visit our contact pages for press inquiries.



government regulations, industrial unrest, and electricity failure amongst other factors not forgetting natural disasters that are beyond the firm's control. In the event of such unavoidable circumstances, ONYX's obligations are put off and try our level best to solve the matter generally and as quick as possible.

GOVERNING LAW

ONYX work and operate within the United States law. Therefore, a client should agree to involve United States courts to decide during any conflict.

All personal information saved at onyxmotorbikes.com will be handled with most care.

Clients' personal information is highly confidential, and no third parties have access to that information other than onyxmotorbikes.com and the client. The personal information saved will be used only to ensure the client gets the full good services provided by onyxmotorbikes.com. The information will be for informing the clients about the special offers offered by onyxmotorbikes.com as well as marketing activities.

Third party access to clients' personal information is only after high necessity to fulfill the above-described purposes. Clients have the option not to be notified by ONYX during registration to the website.

To stop receiving information from ONYX needs stating an email address and brief description of the issue to <https://onyxmotorbikes.zendesk.com/>.

To request the kind of information kept in the system, one may send a request email to <https://onyxmotorbikes.zendesk.com/>. In case of any complaint regarding the information, an individual has the right to have the information deleted or corrected. Customers using cards for payment are conditioned for validity checks. ONYX, therefore, has the right to hold orders in case of security concerns.

PURCHASE, PAYMENT & PRICING

The bike will be shipped when full payment from the customer has been received by ONYX.

CANCELLATION PERIOD OF PAYMENT

On the date of purchase a non-refundable charge of \$299 USD will be deducted from the purchase amount.

ACCOUNT REGISTRATION

When paying for the ONYX bike, you will be required to provide certain information, such as your address and billing information. It is your responsibility that all such information is accurate, and you shall ensure that such information is kept current. ONYX shall have no responsibility or liability for inaccurate information that later becomes outdated, and shall have no obligation to make efforts to determine the correct contact or shipping information.

You can update your information at any time prior to your product being shipped by sending e-mail to <https://onyxmotorbikes.zendesk.com/>

OVERSUBSCRIPTION OF BIKES

ONYX may decline Payment to avoid oversubscription of ONYX bikes. If your Payment is declined, you will be notified and your Payment will be refunded in full.



RCR MODEL

ACKNOWLEDGEMENTS

The Customer acknowledges that he or she is at least 18 years old and eligible to enter into a legal contract with ONYX.

PAYMENT & PRICING

Accepted payment methods are by Visa, MasterCard, Amex, Discover Card, Amazon Pay, Google Pay, cryptocurrency (through coinbase) amount is charged with dispatching the item. Price shall be paid in US Dollars (USD).

We also offer a payment plan through Klarna.

SHIPPING & DELIVERY

When shipping ONYX bikes, ONYX will keep the customer updated on the preliminary date of shipping and send a notification when a bike is ready to be shipped.

SHIPPING PRODUCTS OTHER THAN ONYX BIKES

Shipping of the orders other than ONYX bikes takes two business days after card clearance and availability of stock confirmed. The operation is on weekdays except on public holidays. A preliminary confirmation is always sent after placing an order. Final confirmation is sent after shipping the package with directions on tracking and collecting your package.

USA

For these collections, it takes around ten to fourteen working days for delivery. Additional fees may be added depending on the state.

No delivery to post office boxes due to restrictions by courier services and credit card scam risks. Sending orders to multiple addresses require placing an order for each address, no combination and there will be charges for every order. Extra duties and charges: Please see the 'Payment & Prices' section

UNCOLLECTED ITEMS

No refunding of shipping costs for failed collection of items.

TRACK YOUR ORDER

Haul bikes will be in contact with the purchaser once your bike has been shipped from one of our facilities.

ONYX is temporarily unable to have tracking information automatically emailed for your order. Please email ONYX customer service for tracking information.



DELIVERY SCHEDULE

Although ONYX will make efforts to begin delivering your ONYX bike or other product as soon as reasonably possible, you understand and agree that there may be delays. An estimated time of delivery (ETD) is only an estimate, is subject to change, and ONYX does not guarantee that it will be able to ship the ONYX bike by the estimated date. As a result, in the event that a delay arises and the estimated shipment and/or release of the ONYX bike is not met, ONYX is not responsible for any damages that may occur due to the delay, nor shall it be obligated, to provide any discounts, refunds or credits due to any such delays. ONYX will provide you periodical updates with information regarding the delivery schedule.

PRIORITY OF ONYX BIKES DELIVERED

Priority of ONYX bikes orders is determined by the sequence of orders received and paid for. We will be building the orders in a numerically sequential order and will keep that order for builds and delivery.

DISCLAIMER

At times, there might be a deficit of stock at the time customer places an order at onyxmotorbikes.com web. During such times, we try to contact our clients by email.

There is a time when there are inaccuracies or other errors concerning the content of onyxmotorbikes.com. ONYX, therefore, doesn't warranty this uncertainty caused by such errors. Moreover, ONYX cannot guarantee that all content is updated since they can be altered at any time.

Errors are prone to occur, but ONYX tries to best present displays free of error texts, images, as well as prices in the site and web shop. When a client feels that he/she have been wrongly charged, there is an option to place another correctly priced order or cancel the pending order. If the communication between the client and us is not able to go through, the request may be automatically withdrawn.

DISCLAIMER & LIMITATION OF LIABILITY

Our bikes can be hazardous to operate and we care about your safety, so please note that;

- All riders should ride well within the limits of their abilities, never beyond them.
- Our bikes are recommended for those aged 18 years and older.
- We recommend that all new riders take a relevant training course.
- Make sure that you ride on a permitted area and/or with the landowners consent.
- Always wear a helmet, eye protection and protective clothing, including an approved back protector.
- Never carry passengers.
- Never engage in stunt riding.
- Riding and alcohol/drugs don't mix. It is illegal and dangerous.

7
4



RCR MODEL

- Avoid excessive speed and be particularly careful on difficult terrain.
- All performance modifications and installations are at your own risk.
- Never change the voltage level or tamper with the battery. Doing so can result in a short circuit, fire and/or personal injuries.
- By purchasing and/or riding our bikes, you take full responsibility for any use, and/or misuse of the product and agree that ONYX holds no responsibility for any consequences, legal, or other, of such use and/or misuse.
- Finally, read the owner's manual carefully, follow all instructions therein and enjoy your bike!

RETURNS & EXCHANGES

Every bike is individually built to order which requires us to allocate funds to facilitate the build. On the date of purchase, a non-refundable fee of \$299 will be deducted from the total refundable amount.

30 days after a bike is delivered, it will no longer be eligible for a return.

In the event of a valid return, the order must be returned to us in perfect condition and accompanied by the original invoice. ONYX cannot accept returns where labels have been removed or tampered with in any way. Shipping charges on returned merchandise are at the customer's expense.

The following are the procedures to follow when returning the item. How to proceed with a return:

Kindly contact <https://onyxmotorbikes.zendesk.com/> for how to go through with the whole process of your return. Restate your order number. Furthermore, clarify which items you are sending back and stating clearly why you wish to return them.

RETURN INSTRUCTIONS

- Return of an item requires possession of a return authorization (RA) number; without which there will be no acceptance of the returned item.
- To obtain a return authorization, contact us via email using the information illustrated below:
<https://onyxmotorbikes.zendesk.com/>
- To return a package, you should inform us within a month since the day the package was received. ONYX has no responsibility resulting from damage or loss of the item since we recommend you insure the item via logistics and keep tracking number until complete refund has been done.
- Returned item should be in untouched condition with original tags placed on the package.
- The packaging of the manufacturer should be visible either in writing or marks.
- The customer is responsible for the return shipping costs, and other extra costs and ONYX will only call for return when there was shipment error in this case we cater for such expenses.



WARRANTY & COMPLAINTS

ONYX assures the legitimacy of our products to be of high quality and destined for their recommended purpose with no problems with manufacturing process or craftsmanship. In case of any issue with our product, kindly inform us through email before returning to cut off charges for posting an item. For items bought through our website email us at <https://onyxmotorbikes.zendesk.com/>. We will respond to your claim with a solution and return procedure when necessary.

If you have any inquiry concerning our warranty contact us at <https://onyxmotorbikes.zendesk.com/>.

FULL WARRANTY POLICY ONYX BIKES

ONYX warrants that the bikes sold by ONYX are free of manufacturing defects in material and workmanship when delivered to the buyer.

The warranty on each component on the bike is limited to 30 days from the date of delivery and is limited to the original buyer. Example: if a drive train part for some reason would malfunction, that whole part will be replaced.

The warranty does not cover against damages caused by normal wear and tear.

The warranty does not apply in the event of abuse, neglect, carelessness, using the product in any way other than intended, replacement with any part or accessory other than original ONYX parts and products, attempt of reparation or modification unless expressly permitted in writing by ONYX.

ONYX waives all responsibility for any third party for consequences that might result from the use or handling of any ONYX product by any legal or natural person.

FULL WARRANTY POLICY ONYX PRODUCTS, OTHER THAN BIKES

ONYX warrants that the products sold by ONYX are free of manufacturing defects in material and workmanship when delivered to the buyer.

The warranty is limited to 30 days from the date of delivery and is limited to the original buyer.

The warranty does not cover against damages caused by normal wear and tear.

The warranty does not apply in the event of abuse, neglect, carelessness, using the product in any way other than intended, replacement with any part or accessory other than original ONYX parts and products, attempt of reparation or modification unless expressly permitted in writing by ONYX.

ONYX waives all responsibility for any third party for consequences that might result from the use or handling of any ONYX product by any legal or natural person.



RCR MODEL

COMPLAINTS

A customer who has complaints on a product can do so within 30 days after purchase. ONYX urges a customer to make a complaint within 30 days4 of purchase to repair or replace a faulty component, according to the customer's wishes.

Complaints are administrated via <https://onyxmotorbikes.zendesk.com/>

PRIVACY POLICY

ONYX is the controller of Personal Data with respect to the Services, but other ONYX companies may operate as processors or co-controllers of some Personal Data e.g. with regard to hotel reservations. "Personal Data" means any and all information, which can be directly or indirectly linked, to a living natural person.

We strive to maintain a high level of protection of personal privacy. ONYX uses Personal Data primarily to administer, provide, develop and maintain the Services, process your reservations, optimize your experience with respect to the Services and individualize the communication with you. Please read this Privacy Policy carefully to understand how and for what purposes we process your Personal Data. By providing your Personal Data to us and accepting the applicable terms and conditions, you consent to your Personal Data being processed in accordance with the provisions set forth in the separate terms and conditions for each Service and this Privacy Policy. If a more specific consent is required from you by law, we will of course ask you for such specific consent.

This Privacy Policy together with Terms and Conditions, ONYX's Cookie Policy and any other separate terms and conditions governing ONYX's processing of Personal Data from time to time, are together referred to as the "Privacy Terms". The Privacy Terms state the basis for the manner in which we process Personal Data that you provide to us when you use the Services or that we collect regarding you. Thus, with respect to some of our Services, there are also separate terms and conditions for the processing of Personal Data that you accept when you use each Service.

Changes to this Privacy Policy are announced by the new terms and conditions being published on ONYX's websites and we therefore recommend that you regularly review these.

If you add Personal Data regarding other people, you are responsible for ensuring that ONYX may also process that Personal Data in accordance with the applicable Privacy Terms.

COLLECTION AND PROCESSING OF PERSONAL DATA

ONYX collects and processes your Personal Data only where permitted by law. The collection and processing may take place when you use the Services, e.g. placing an order of an ONYX motorbike with billing and shipping information. We use various methods to collect Personal Data such as cookies, web beacons, customer surveys and membership services. At various times, ONYX compiles or imports Personal Data from databases (e.g. from Facebook or Google) within and outside ONYX. From time to time we receive Personal Data regarding you from companies within ONYX, cooperation partners and other information that may be added to your profile (if a profile has been created).

It is important for ONYX to keep your Personal Data up to date and accurate at all times, why we may import Personal Data about you from external sources such as public registers.



When the law requires that consent be obtained for the processing of certain types of Personal Data or for certain forms of processing, consent will be obtained from you before processing takes place.

INFORMATION FROM AND ABOUT YOU THAT WE COLLECT AND PROCESS

We only collect Personal Data relevant for the purpose described in the separate terms and conditions for each Service and this Privacy Policy. The information we may collect is, for example, information regarding name, address, telephone number, email address, IP address, information to facilitate the use of the Services (such as login), default language, user history, payments and other information you provide when using the Services. Examples of Personal Data collected from companies outside ONYX may include, updated address information and demographic information.

WHERE WE STORE AS WELL AS TRANSFER YOUR PERSONAL DATA

ONYX stores Personal Data in compliance with this Privacy Policy and applicable legislation. Personal Data may be transferred between ONYX entities for the sake of their processing for the purposes contemplated under the Privacy Terms. ONYX uses subcontractors, for example, for computer operations, and Personal Data may be transferred to these subcontractors. Our subcontractors process your Personal Data only on behalf of ONYX, as per our instructions and only after they have executed a data processor agreement pursuant to applicable law, in order to enable us to ensure a high level of protection for your Personal Data.

ONYX may disclose Personal Data to third parties such as the police or other public authority, if the matter concerns the investigation of a crime, or ONYX is otherwise required to disclose such information by law or decision of a public authority.

Generally, ONYX does not transfer Personal Data to countries outside the United States; however, if we, for example, have a subcontractor located in a country outside the United States or it is necessary for us in order to fulfill our contractual obligations towards you, a transfer of Personal Data outside the United States may take place even if that country does not have an adequate level of protection for Personal Data according to US Law. To ensure a high level of protection for your Personal Data in those situations and compliance with US regulations, ONYX enters into data processor agreements with such subcontractors. Such processor agreement will regulate the subcontractors' processing of the Personal Data and, when applicable, the transfer of Personal Data, pursuant to applicable US data protection regulation. The agreements contain terms and conditions which the United States requires and which fulfill the requirements of applicable data protection laws.

PROTECTION AND DELETION OF PERSONAL DATA

ONYX has taken appropriate technical and organizational measures to protect your data against, for example, loss, manipulation or unauthorized access. We adapt our security measures to meet the continuous development of technology.

ONYX deletes Personal Data in accordance with applicable law. This means, for example, that ONYX deletes or depersonalizes Personal Data when there is no longer a purpose for processing the Personal Data. The purposes for which we process your Personal Data are described in Section 3 above and the Privacy Terms.

OTHER APPLICATIONS/WEBSITES

The Services may contain links to other applications and/or websites not controlled by ONYX. This Privacy Policy is only applicable to your use of the Services. ONYX is not responsible for the content of linked applications/websites and the processing of Personal Data that might be undertaken by the owner or operator of linked websites.



CHANGE, DELETE AND REVIEW YOUR PERSONAL DATA

ONYX ensures that other ONYX companies receive clear guidelines concerning the processing of Personal Data and defines the purposes for which ONYX will use Personal Data. If your Personal Data change, please inform ONYX of this by sending an email to <https://onyxmotorbikes.zendesk.com/>. ONYX is not responsible for problems, which arise due to data being out of date or inaccurate if you have failed to inform us of such changes.

ONYX will, upon your request or whenever discovered by ONYX, correct or delete inaccurate or incomplete information. You are also entitled without charge to receive a transcript of the Personal Data being processed about you. Requests for transcripts must be made in writing to ONYX to <https://onyxmotorbikes.zendesk.com/> and shall be signed by you and contain your name, post address, phone number, email address (used in communication with ONYX). The transcript will be sent to your registered address within one month of the date the request is received by ONYX. The frequency of which you are entitled to receive such transcripts may vary depending on where you are domiciled.

You may at any time revoke your consent to further processing (not retroactively) of your Personal Data by contacting ONYX at the address set out in Section 10, whereupon ONYX will block such information from further processing. However, a withdrawal of consent may lead to deteriorated Services or impossibility for ONYX to provide Services.

ASSIGNMENT

If we sell, re-organize or otherwise transfer all or part of our business, your Personal Data may be transferred simultaneously.

CONTACT

If you have any questions, comments or complaints related to ONYX's processing of Personal Data and compliance with the Privacy Terms or applicable legislation on the protection of Personal Data, please send a letter to ONYX Motorbikes: 1924A E Maple Ave. El Segundo, CA 90245. If necessary ONYX will ensure that your letter is transferred to and handled by the relevant ONYX company.

COOKIE POLICY

ONYX's site uses cookies as described below. By not turning off cookies in your browser and continuing to use this site, you agree to our use of cookies in accordance with this Cookie Policy and to the underlying personal data processing (if applicable). Please refer to our Privacy Policy for additional information about what, how and for what purposes ONYX processes personal data and your right to access your personal data processed by ONYX.

To ensure the customer experience is maintained, ONYX uses cookies which identifies the device and thereby allows the site to trace clients' personal settings. This helps in improving customer experience. Cookies help with statistical issues and concerns.

You can change your choice by amending your browser settings at any time. If you disable cookies that we use, this may impact your user experience while on the ONYX site.



WHAT ARE COOKIES AND WHAT ARE THEY USED FOR?

Cookies are small text files which are sent to and stored on your device (mobile phone, computer or tablet) and which are common on the Internet. Some of the cookies are necessary to enable you to use the site's full functionality, while others are used in order to improve your user experience and facilitate navigation on the site.

There are two types of cookies: permanent and temporary (so-called session cookies). Permanent cookies are saved as a file on your device for a longer period of time in order to customize the site according to your wishes, selections and interests. They are used, for example, in connection with functions that tell you what is new since you last visited the site. When the expiration date is exceeded, the cookie is deleted when you return to the site that created it. Session cookies are placed temporarily on your computer when you visit the site, and are sent between your computer and the server during the time you visit the site and are deleted when you close your browser. These cookies are used, for example, to keep track of what language you have selected.

SOME EXAMPLES OF WHAT COOKIES CAN BE USED FOR:

- When you log onto a site a cookie is placed on your computer. In connection with each page change, your computer sends a cookie to the site you are visiting and, using the cookie, the site can determine that you are logged in and you avoid having to provide a username and password for each new page.
- When you want to tailor sites to your preferences. These preferences may concern the design on a site you visit often, customized contrast or font size, or customized sorting or selections.
- On sites that sell services, cookies are used to facilitate bookings or orders. Registering which people have visited which pages on a site. This information can then be used to choose the right advertisement or otherwise
- tailoring the pages the user may view. Many cookies used for advertising and tailoring content are third-party cookies. Monitoring the traffic through statistics to improve the site and learn more about different target groups. Many cookies used for statistics are
- third-party cookies. Keeping track of selected language, booking codes or membership levels.

DIFFERENT TYPES OF COOKIES

- - Cookies can be divided into categories depending on their function.
- -Required: These are necessary for certain functions to work. This may be the case, for example, in order to identify and authenticate the user in connection with logging into ONYX Friends and in connection with payment. If you refuse to accept these cookies, you will not be able to use the relevant functionality.
- -Presentation and function: These cookies make your use of the site easier and more personal, for example, by customizing information and offers to things in which you have previously shown interest. These cookies are also used to collect information (e.g. popular pages and user patterns) regarding ONYX's visitors' use of the site so that ONYX can improve the site and ONYX's digital services. If you refuse to accept these
- cookies, the functionality of ONYX's digital services will be limited.
- -Promotion: These cookies are often third-party cookies, i.e. they are not used by ONYX but by one of ONYX's partners. These cookies use information regarding your use of ONYX's site and other parties' sites, for example, sites you visit or advertisements you respond to, in order to subsequently provide advertisements which are more suited to you, both on ONYX's site and other parties' sites. These advertisements are called "interest based ads" since the purpose is for you to only need to view advertisements which suit your interests. If you refuse to accept these



IF YOU WISH TO AVOID COOKIES

Cookies are not used to damage or destroy your computer and most browsers automatically accept cookies. If, however, you do not wish to allow cookies, you can refuse to accept cookies in your browser's settings and delete cookies stored on your hard drive. You can also set your browser such that it notifies you when it receives a cookie. This way, you have the opportunity to accept or reject the cookie. More information regarding cookies and your browser settings can be obtained from your browser provider. You can also receive further information at www.youronlinechoices.eu. However, ONYX does not control certain third-party cookies. These cookies may only be turned off on the relevant site and in accordance with the instructions provided there.

If you refuse cookies, this may result in the digital services not working as intended.

WHY DOES ONYX USE COOKIES?

By using cookies, ONYX's site recognizes your device when you visit us again and you avoid providing certain data each time you use ONYX's digital services. Cookies also assist ONYX in customizing the services to meet your needs, for example, so you avoid having to choose a language. Because the cookie keeps track of what you previously expressed interest in, ONYX displays information and offers from companies within and outside the ONYX group which hopefully suit your individual wishes. Quite simply, the site becomes easier to use.

ONYX also uses cookies for evaluating search and user behavior within and outside ONYX's site in order to further develop ONYX's digital services. The aim is to optimize the user experience, individualize marketing and keep statistics. The information may be shared with other companies operating ONYX branded products.

We may also use other companies that, on ONYX's behalf, place cookies to deliver services they provide.

CONSENT TO USE COOKIES

You consent to ONYX's use of cookies in accordance with this Cookie Policy by continuing to use the site and using a browser set to allow cookies

CHANGES TO ONYX'S COOKIES

The cookies that ONYX uses and the changes made by ONYX are only stated through ONYX's updates of the table set forth below. Thus, we suggest that you check the table each time you visit the site.

CONTACT

Questions and comments regarding ONYX's Cookie Policy are welcome and should be sent to <https://onyxmotorbikes.zendesk.com/>.

Supplementary information regarding how ONYX processes personal data is stated in ONYX's Privacy Policy applicable from time to time.

COOKIES USED BY ONYX

ONYX's digital services collect and store information using technology from various measuring tools. The information can be used to create profiles under a pseudonym. Cookies may be used for this purpose. We also use third party cookies, mainly for measuring traffic and/or determine which digital service you last visited.

PRIVACY POLICY

Client's personal information is highly confidential, and no third party has access to them other than onyxmotorbikes.com and the client. The personal information saved will be used only to ensure the client gets the full good services provided by the onyxmotorbikes.com. The information will be for informing the clients about the special offers offered by onyxmotorbikes.com as well as marketing activities.

Third party access to clients' personal information is only after high necessity to fulfill the above-described purposes. Clients have the option not to be notified by ONYX during registration to the website. To stop receiving information from ONYX needs stating an email address and brief description of the issue to <https://onyxmotorbikes.zendesk.com/>.

To request the kind of information kept in the system, one may send a request email to <https://onyxmotorbikes.zendesk.com/>. In case of any complaint regarding the report, an individual has the right to have the information deleted or corrected. Customers using cards for payment are conditioned for validity checks. ONYX, therefore, has the right to hold orders in case of security concerns.

SECURITY

ONYX uses Secure Socket Layers (SSL) in processing orders. ONYX ecommerce site uses the Thawte SSL Certificates to ensure confidentiality of communications that involves encryption of data to and from the site. To confirm security validity when placing an order, you can click on the Thawte icon.

LINKS

There are other links to an external source that might be contained in onyxmotorbikes.com that are beyond the control of the site. The site is therefore not responsible for the content of security policies of such external sites.

THE COLORS

The image colors in the website may not be fully compatible to the actual color of the item since this may involve your computer settings. The site, therefore, doesn't guarantee this color matching.

FIRST RESPONDER INFORMATION

This bike contains a 72V battery connected by phase wires to a rear hub motor.

NEVER cut any high voltage cables or cabling.

High voltage cables can hold charge for up to 60 seconds after disabling the vehicle.

HIGH VOLTAGE COMPONENT LOCATIONS

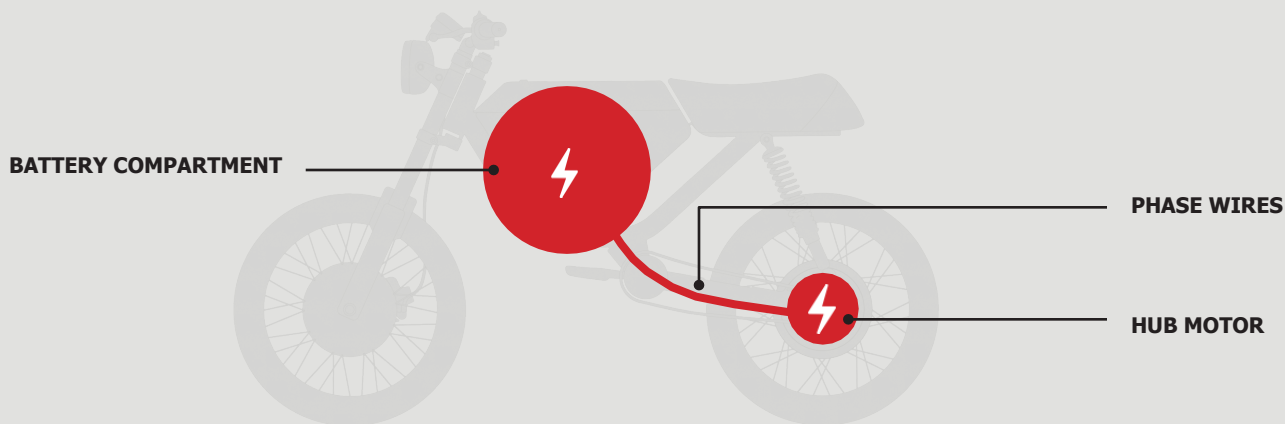



MO PED S ARE BA CK
!

onyxmotorbikes.com
info@onyxmotorbikes.co
[m](#)



@onyxmotorbike
s



@onyxmotorbike
s



@onyxmotorbike
s