



**INSTALLATION INSTRUCTIONS / OWNER'S MANUAL:  
TOY BOX  
OFF-ROAD BED TOP / CAMPER SHELL FOR CAN-AM DEFENDER**

*www.hoppeindustries.com*  
22667 FM 15 Troup, TX 75789  
(262) 552-2770

Thank you for choosing the Hoppe *Toy Box* off road bed top / camper shell. We hope you enjoy the product and we ask that you follow these instructions very closely. Doing so will save you time and ensure that your experience with the new *Toy Box* is a positive one.

**We strongly suggest that you read the complete instructions before beginning the installation process to eliminate the possibility of performing unnecessary work.**

Having a safe and clean environment and using the proper tools is essential for a successful installation.

**It is critical that proper eye wear, ear protection, and protective clothing is worn throughout the top installation.**

When you receive your *Toy Box* off-road top, please check to ensure that all parts and hardware are included. If there are any parts missing or if you have any questions concerning the top at this time call Hoppe at (262)-552-2770 Mon-Thur. 8am-5pm CST. Or you can email us at [tech@hoppeindustries.com](mailto:tech@hoppeindustries.com).

Hoppe reserves the right to change specifications, equipment, or designs at any time without notice and without incurring obligation.

# **TABLE OF CONTENTS**

SECTION 1 – <i>Tools Required</i> .....	4
SECTION 2 – <i>About your Audio Shade Top</i> .....	4
2.1 Applicable Year Models: .....	4
2.2 Audio Equipment Details:.....	4
2.3 Warranty: .....	4
2.4 Care and Maintenance: .....	5
2.5 Warnings: .....	5
SECTION 3 – <i>Pre-Installation Inspection</i> .....	6
SECTION 4 – <i>Installation</i> .....	7

## **SECTION 1 – Tools Required**

- Socket wrench set
- Combination wrench set
- Small impact or screw gun
- Cordless drill and bits.
- Wire cutters
- Screw driver set

In addition to the above items, you may need shop supplies such as electrical tape, wire ties, thread locking compound.

## **SECTION 2 – About your Toy Box top**

### **2.1 Applicable Year Models:**

This *Toy Box* top is designed to fit the following Defender models:

- 2017-2024 DEFENDER HD5
- 2016-2024 DEFENDER HD8 & DEFENDER HD10 (all versions except 6x6 and Pro)
- 2017-2024 DEFENDER MAX HD8 & DEFENDER MAX HD10 (all versions)
- XMR models will require the snorkel to be removed and converted to standard air intake.
- Fits standard short bed only. Long bed 6x6 and Pro models are excluded

### **2.2 Equipment Details:**

Your *Toy Box* top is constructed of durable aluminum. At under 70 lbs. it is designed to be light weight and maximize overall payload capacity while remaining durable.

The factory tilt bed will remain functional. However, we recommend you un-latch the bed, then walk to the back and use the top corner of the top as leverage to dump return the bed in a controlled manner.

### **2.3 Warranty:**

Your *Toy Box* top comes equipped with a 1-year limited warranty covering the entire assembly. The date of warranty coverage will be determined by the registration date of the warranty card or online warranty registration.

<http://www.motortrike.com/TrikeAccWarranty.aspx>

If the warranty is not registered with Hoppe, the warranty period will begin when the *Toy Box* was shipped from Hoppe's factory.

## 2.4 Care and Maintenance:

Your *Toy Box* top does not require any maintenance other than an occasional cleaning. To clean your top, simply hose off or power wash from a distance. If needed, use a mild automotive soap and sponge or brush.

An inline fuse for the interior dome light is located near the battery. The battery is located on the passenger side under the rear most seat. The cover is removed by rotating a quarter turn fastener on each end.

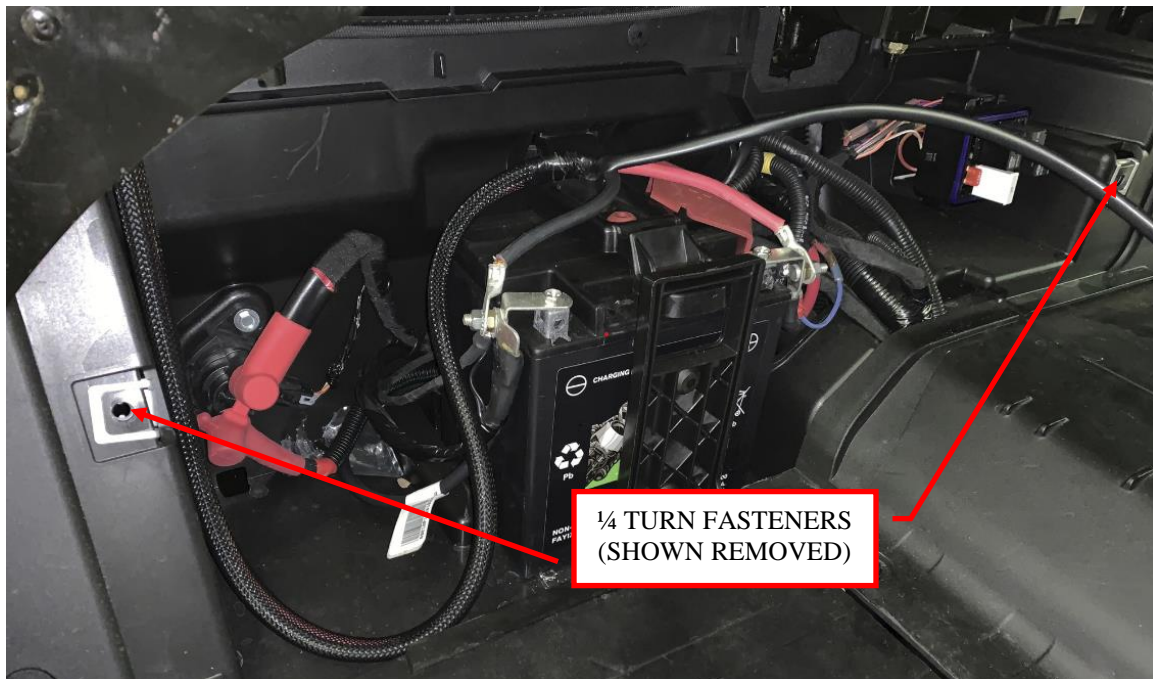


Figure 1: Fuse locations.

## 2.5 Warnings:

This *Toy Box* top adds up to 70 lbs. to your vehicle and is located up high on the bed. This increases the vehicle's center of gravity and can change the vehicle dynamics and handling characteristics. Use extra caution as you learn the driving characteristics of your vehicle's performance with your new top installed. High speed cornering, off camber or side hill, acceleration, and braking performance may be negatively impacted by the weight of the top especially if combined with other equipment and cargo.

## **SECTION 3 – Pre-Installation Inspection**

Included in your *Toy Box* top are the following components:

- 1 aluminum roof panel with hinge installed
- 1 aluminum back wall panel with window installed
- 1 aluminum left side panel
- 1 aluminum right side panel
- 1 aluminum door panel with latches and window installed
- 2 gas struts
- 1 dome light wire harness
- 1 hardware bag.

If any of the parts are missing, damaged, or you have any questions concerning them, please call Hoppe at (262)-552-2770 Mon-Thur. 8am-5pm CST.

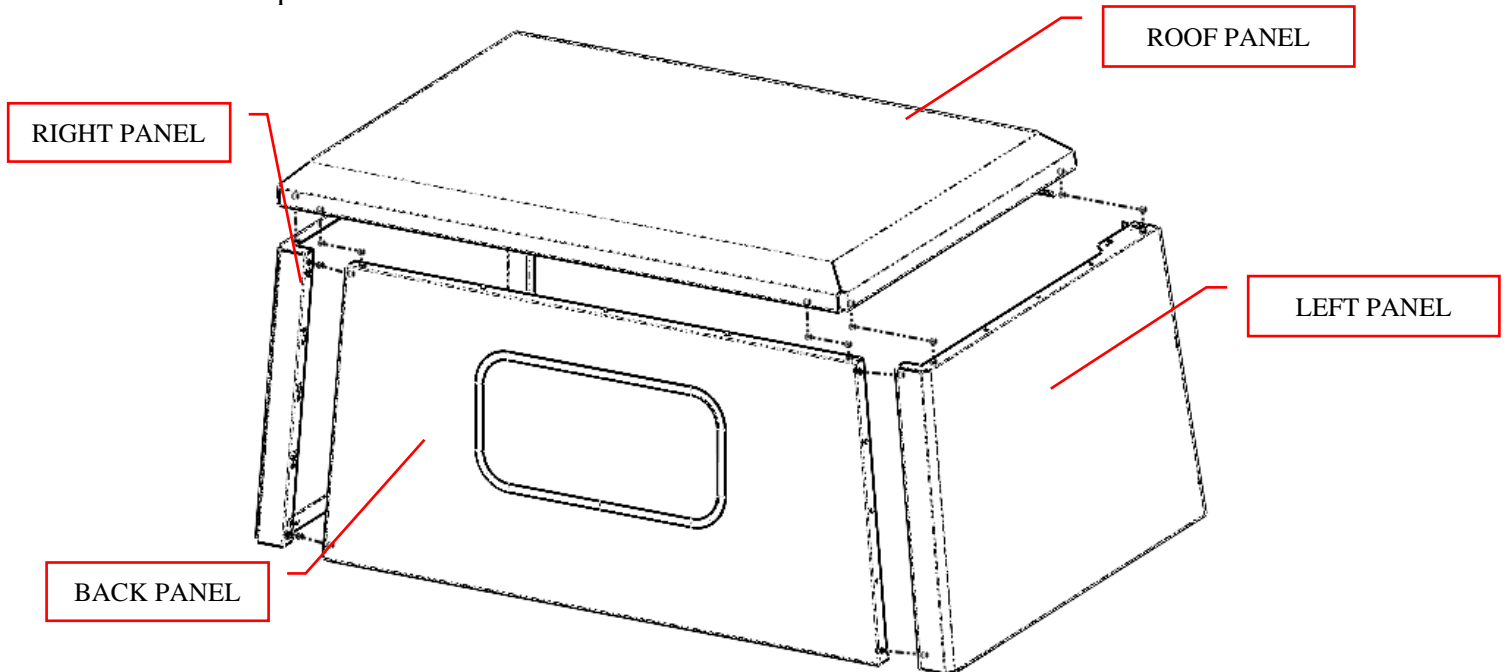
In addition to accounting for all of the parts that you should receive with the top, you should inspect the vehicle in the following ways.

- Ensure that the vehicle is equipped with the factory bed installed and in good condition.
- Make sure the vehicle does not have any aftermarket accessories mounted to the back of the cage that may be incompatible with the top. NOTE: XMR models with snorkels installed are not compatible with this top.

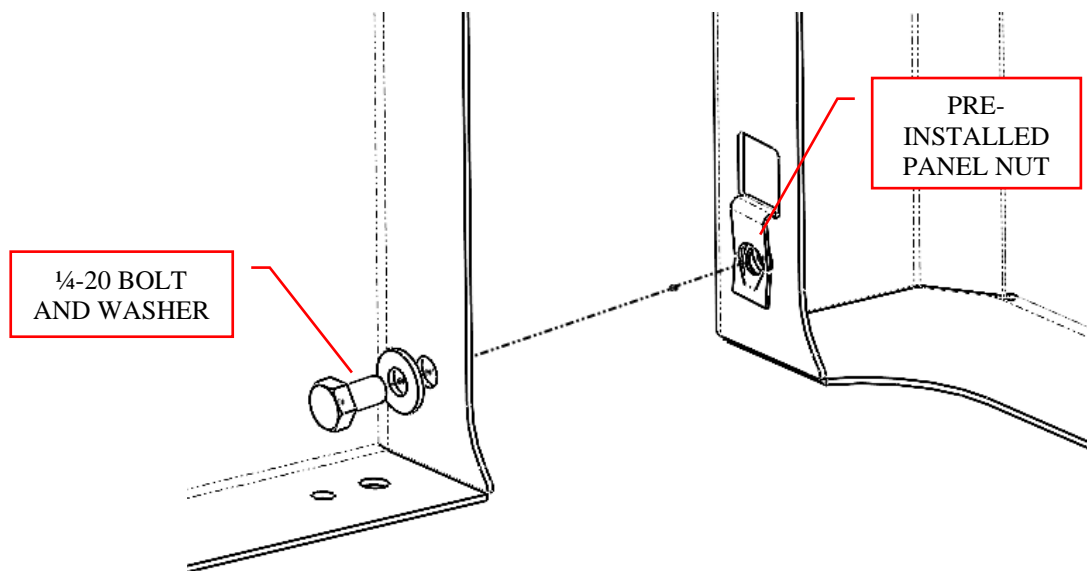
## **SECTION 4 – Installation**

1. Fasten the back panel, left panel, right panel, and roof panel together according to the exploded view. Be sure to put a ¼-20 bolt with washer in each of the pre-installed panel nuts. There is a total of 27 bolts to install, so a small cordless impact or screw gun is recommended. Make sure the seams and corners are flush before tightening the bolts. Torque each bolt to approximately 8 ft\*lbs. See Figure 2 and Figure 3.

NOTE: There will be a piece of foam tape not shown that seals the seams between each panel.



**Figure 2: Exploded view of side, back, and roof panels.**



**Figure 3: Detail of fastener assembly.**

- Using an assistant, set the assembled panels onto the bed walls of the Can-Am Defender. Line up the diamond shaped anchors on the underside of the walls with the corresponding bed holes. See Figure 4.

NOTE: There will be a piece of foam tape not shown that seals the top to the bed walls.

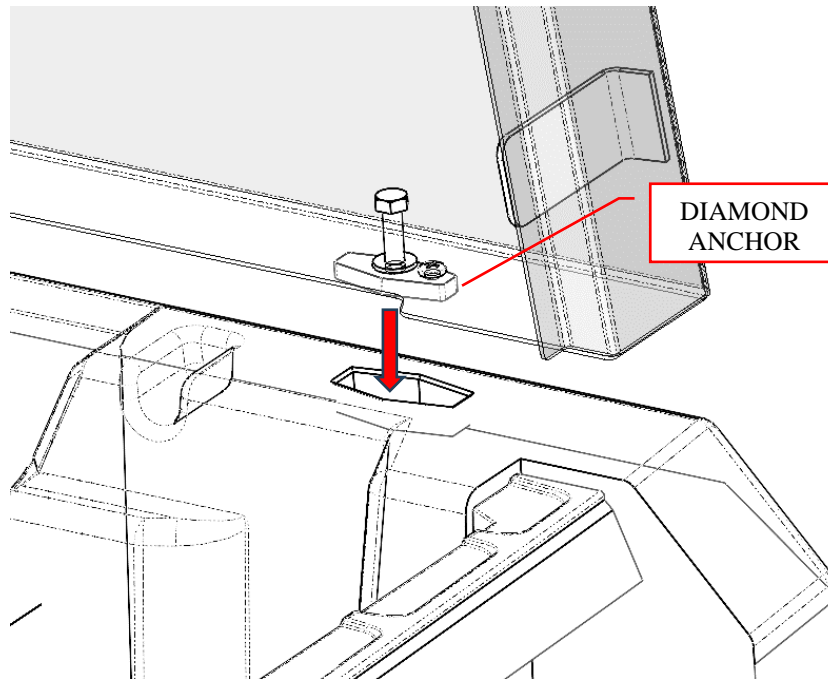
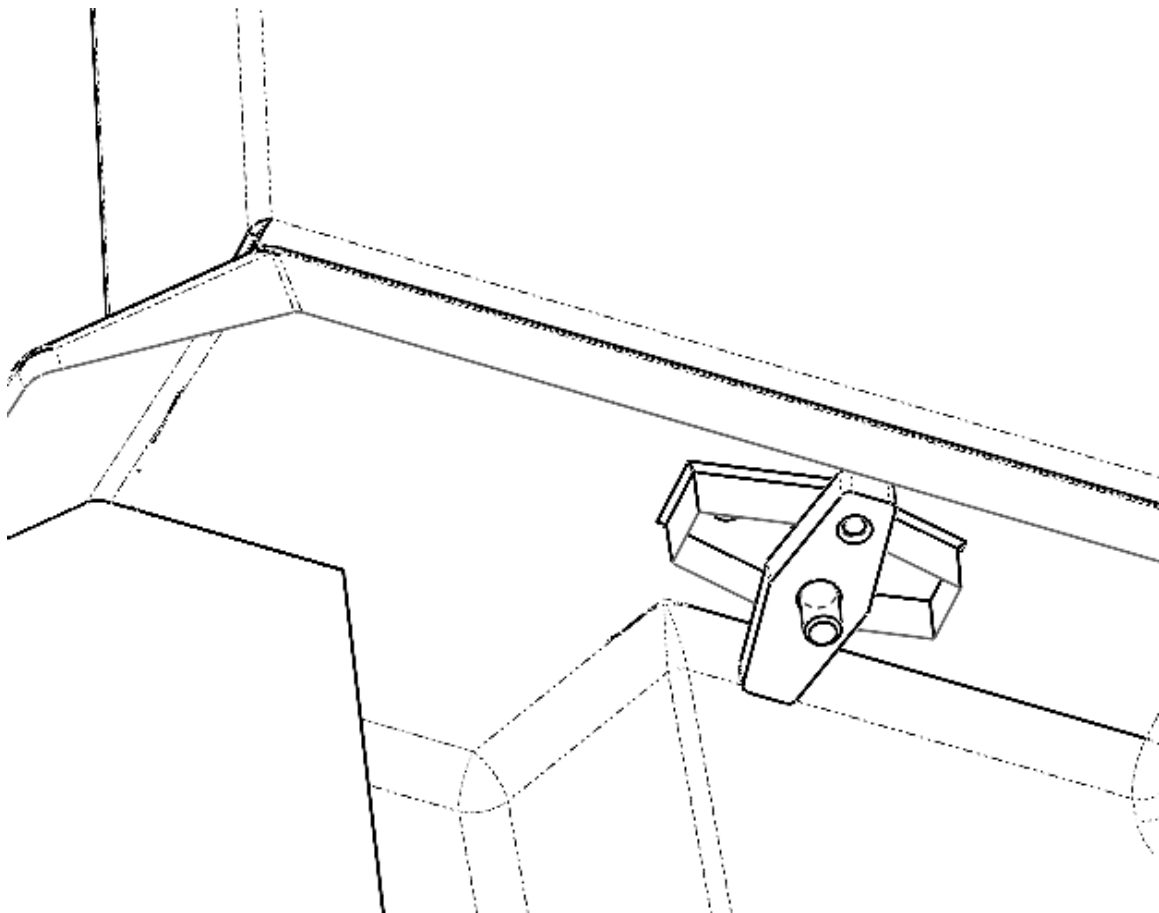


Figure 4: Set the assembled panels on the bed walls.

- Remove the Phillips screw from each diamond anchor and allow the anchor to fall until the  $\frac{1}{4}$ -20 bolt catches it. The Phillips screws can be discarded. Rotate the  $\frac{1}{4}$ -20 hex head bolt by hand 90 degrees, then lift up until you feel the diamond anchor grab the bottom of the bed rail. Finger tighten the screw while maintaining upward pressure until the anchor is in contact. With the outside walls lined up with the top of the bed, torque each  $\frac{1}{4}$ -20 bolt to approximately 8 ft\*lbs. The friction on the anchor will keep it in place once finger tight. See Figure 5.

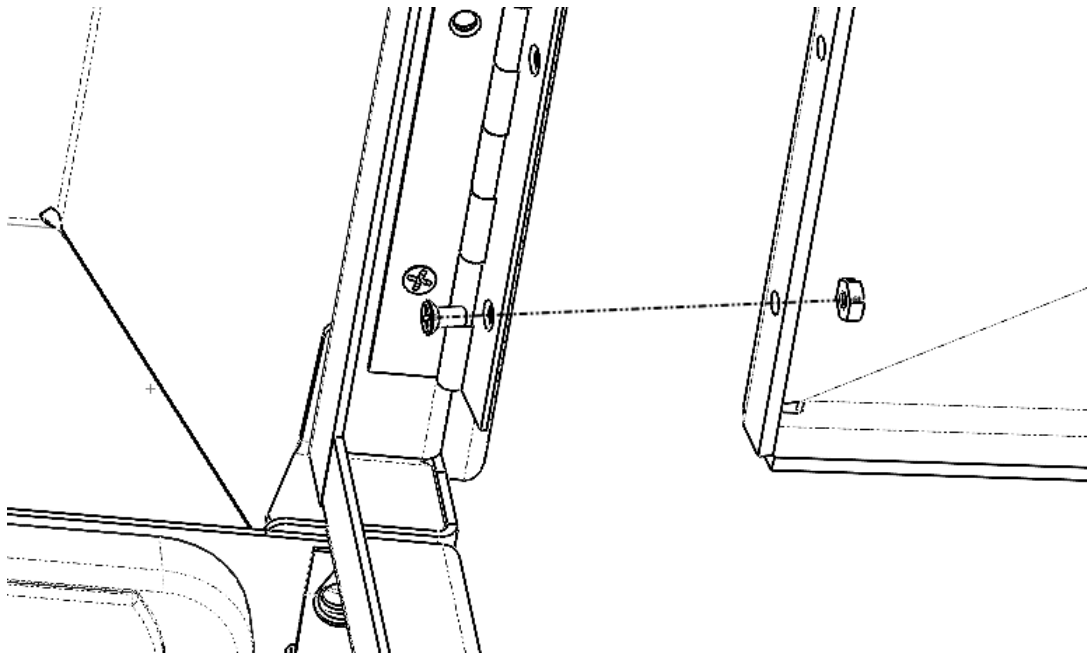
NOTE: Most of the diamond anchors can be held in position from outside of the bed by an assistant if desired. It is not required, but can make the assembly process go a little faster. Once the side walls are secure, you can tilt the bed to access the back wall anchors if desired.





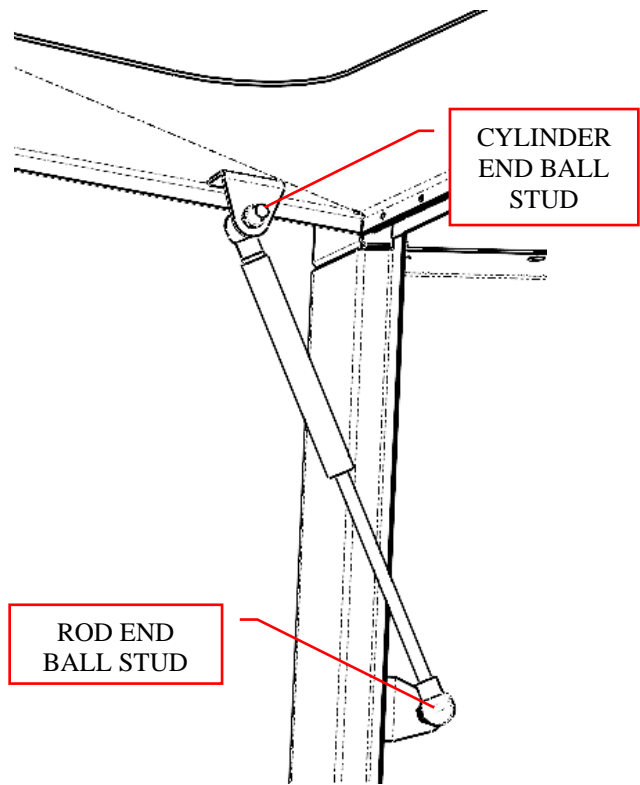
**Figure 5: Diamond anchor shown secured to bed (outside plastic wall of bed hidden for clarity).**

4. With the help of an assistant, screw the door onto the hinge. Use the supplied #4-40 flat head screws and nylock nuts. The fixed side of the hinge is shipped already secured to the roof panel. Tighten all twenty five #4-40 screws / nuts until they begin to make contact, then turn approximately a  $\frac{1}{4}$  turn more. See Figure 6.



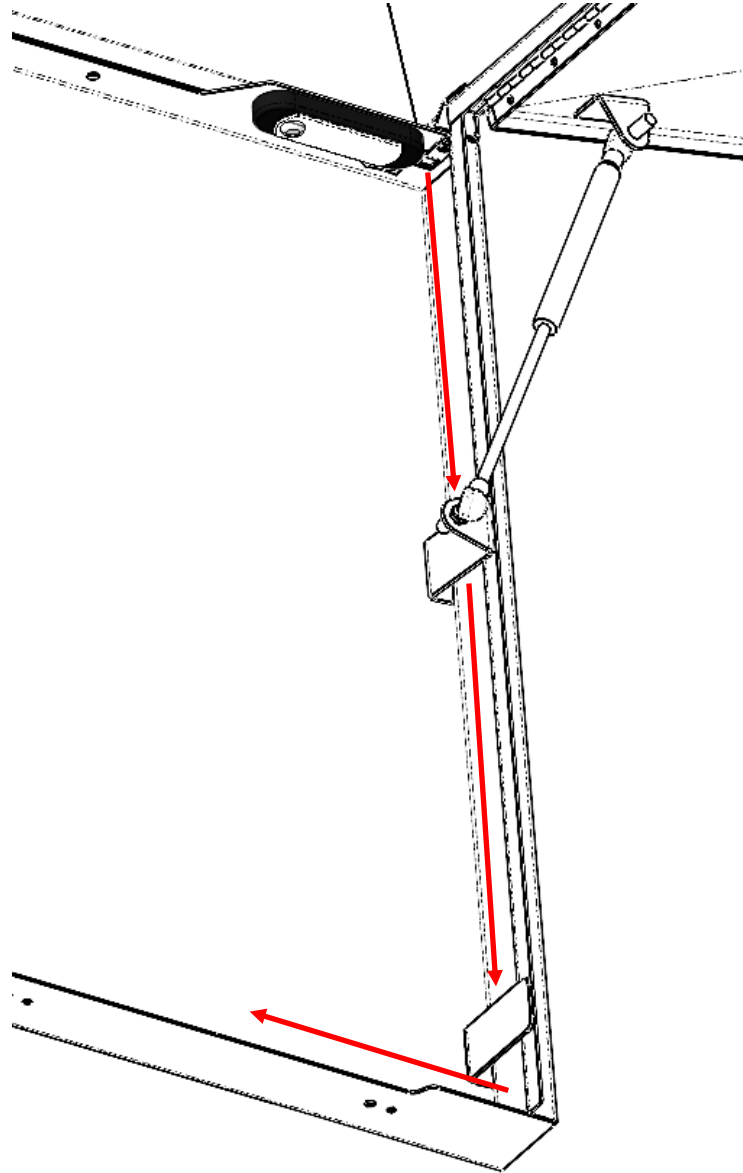
**Figure 6: Attach the door to the hinge.**

5. Snap the gas spring onto the ball studs. Be sure to install with the cylinder end attached to the door and the rod end attached to the wall. The rod end should always be pointed down to ensure the seal remains lubricated. See Figure 7.

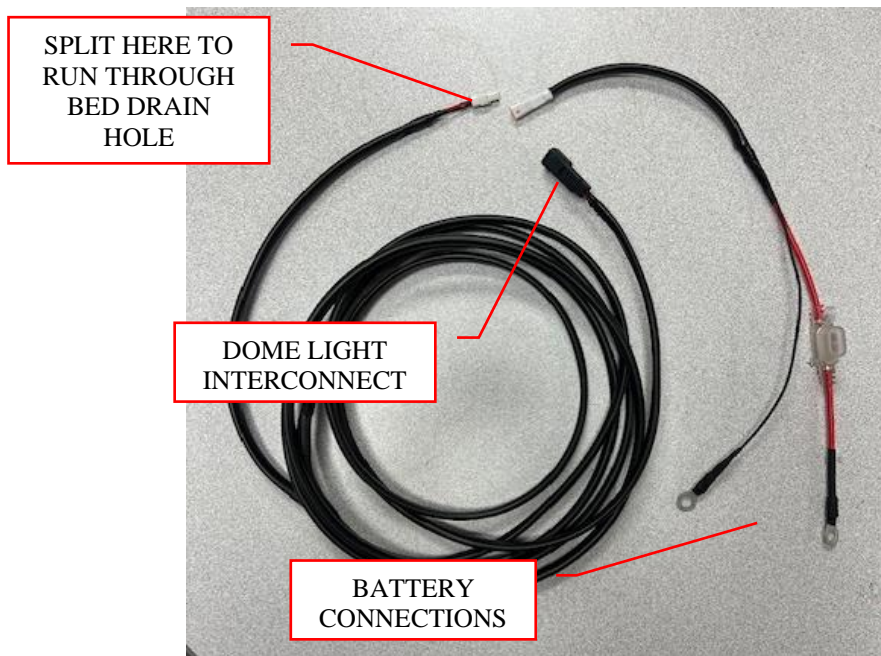


**Figure 7: Attach the gas spring to the ball studs.**

6. Plug the dome light harness into the dome light. Run the other end of the dome light wire harness through the hole in the roof flange next to the dome light and down the back wall behind the gas shock bracket and latch bracket. Note: You must separate the harness so the small connector can pass through the tight spaces and make running the harness easier. See Figure 8 and Figure 9.



**Figure 8: Run the dome light harness on the top.**



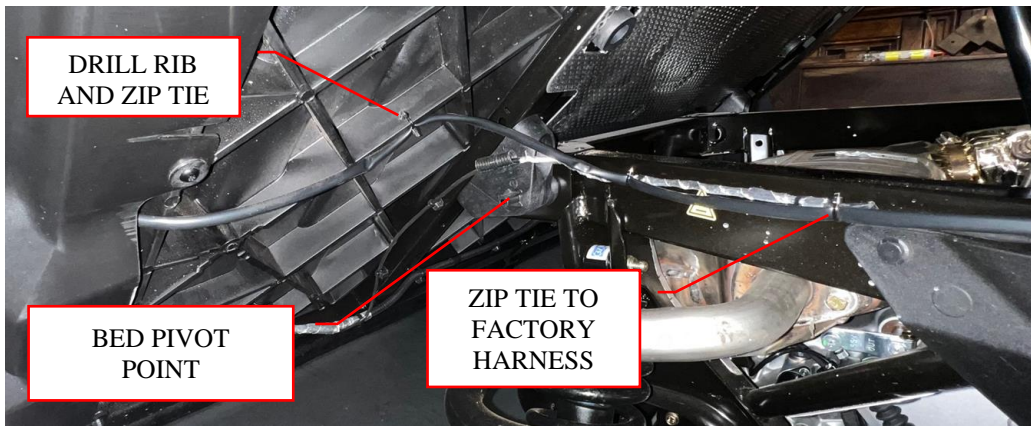
**Figure 9: Wire harness connections.**

7. Push the harness down the bed stake pocket and through the drain hole in the bottom.  
Note: You can drill a small hole in the aluminum bed flange to run the harness through or you can run it over the edge. See Figure 10.



**Figure 10: Run harness through drain hole in bed stake pocket.**

8. Under the bed, drill a small hole through the plastic rib and loosely zip tie the harness up. Continue loosely zip tying the harness along the frame to the factory wire harness moving toward the cab. See Figure 11.



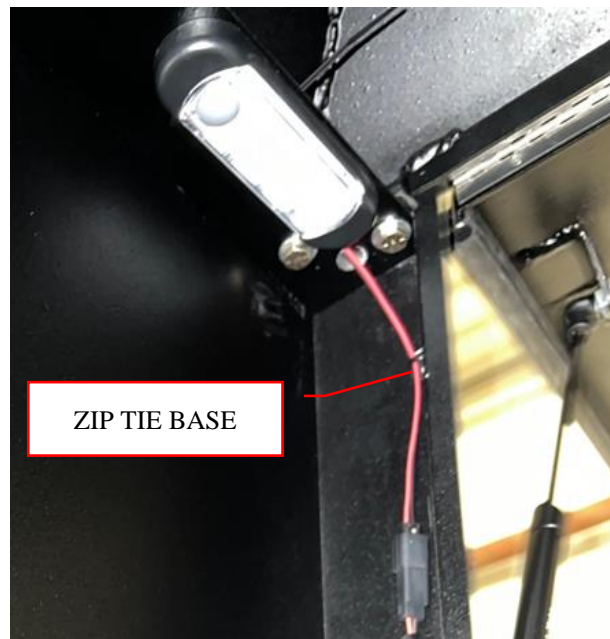
**Figure 11: Run the harness under the bed.**

9. Pass the wire harness through the back wall and into the battery compartment and re-connect the harness once inside the battery compartment. See Figure 12.



**Figure 12: Run into battery compartment.**

10. Connect the red wire with fuse holder to the positive battery post using the ring terminal and 6 mm nut. Similarly, connect the black wire to the negative battery terminal. See Figure 1.
11. Use the supplied stick-on zip tie bases to secure the harness in place inside the top. Make sure you clean under each base with an alcohol wipe before pressing in place. Pull the harness tight to neatly secure along its path through the top, under the bed, and along the frame. Be sure to leave a little slack in the harness near the bed pivot point so it does not get stretched while tilting the bed. See Figure 11 and Figure 13.



**Figure 13: Secure harness with zip tie bases.**

Thank you for choosing Hoppe *Toy Box* off-road top for your Can-Am Defender UTV. We hope you enjoy your new dry storage. We invite you, in your travels, to stop by our manufacturing plant in Troup, Texas, for a factory tour and to meet the people who designed and manufactured your *Toy Box* UTV top. This will also give you an opportunity to check out our sister companies



and our extensive line of trike conversions, automotive, motorcycle, and power sports accessories.

We believe you will be impressed by what you witness and the people you will meet.