



**INSTALLATION INSTRUCTIONS / OWNER'S MANUAL:
AUDIO SHADE
OFF-ROAD TOP FOR CAN-AM MAVERICK X3 MAX (4 seat) MODELS**

www.hoppeindustries.com
22667 FM 15 Troup, TX 75789
(262) 552-2770

Thank you for choosing the Hoppe *Audio Shade* off-road top. We hope you enjoy the off-road top, and we ask that you follow these instructions very closely. Doing so will save you time and ensure that your experience with the new *Audio Shade* is a positive one.

We strongly suggest that you read the complete instructions before beginning the installation process to eliminate the possibility of performing unnecessary work.

Having a safe and clean environment and using the proper tools is essential for a successful installation.

It is critical that proper eye wear, ear protection, and protective clothing is worn throughout the top installation.

When you receive your *Audio Shade* off-road top, please check to ensure that all parts and hardware are included. If there are any parts missing or if you have any questions concerning the top at this time call Hoppe at (262)-552-2770 Mon-Thur. 8am-5pm CST, or you can email us at tech@hoppeindustries.com.

Hoppe reserves the right to change specifications, equipment, or designs at any time without notice and without incurring obligation.

TABLE OF CONTENTS

| | |
|--|---|
| SECTION 1 – <i>Tools Required</i> | 4 |
| SECTION 2 – <i>About your Audio Shade Top</i> | 4 |
| 2.1 Applicable Year Models: | 4 |
| 2.2 Audio Equipment Details:..... | 4 |
| 2.3 Warranty: | 5 |
| 2.4 Care and Maintenance: | 5 |
| 2.5 Warnings:..... | 7 |
| SECTION 3 – <i>Pre-Installation Inspection</i> | 8 |
| SECTION 4 – <i>Installation</i> | 9 |

SECTION 1 – Tools Required

- Socket wrench set
- Combination wrench set
- Wire cutters

In addition to the above items, you may need shop supplies such as electrical tape, wire ties, thread locking compound.

SECTION 2 – About your Audio Shade Top

2.1 Applicable Year Models:

This *Audio Shade* off-road top is designed to fit Maverick X3 MAX models from 2017-2021 (as of 2021 model year).

2.2 Audio Equipment Details:

Your *Audio Shade* off-road top is powered by  using their premium quality power sports series audio equipment. This equipment is designed to function in all weather conditions with an IPX6 water resistance (powerful water jet) rating. The stereo is specifically engineered to provide excellent sound quality and volume in an open air power sports environment so you can enjoy your music on the go.

To learn more details about your stereo system, you can access product information and manuals for the stereo equipment here:

- KMC2 receiver: <https://www.kicker.com/46KMC2>
- Sub-woofer amplifier: <https://www.kicker.com/pxa5001-500-watt-compact-powersports-mono-amplifier>
- Speaker amplifier: <https://www.kicker.com/pxa3004-4-channel-compact-powersports-amplifier>
- Sub-woofers: <https://www.kicker.com/2016-comprt-subwoofers>
- Speakers: <https://www.kicker.com/42PSC654>

Your amplifier gains comes pre-adjusted from the factory and are tuned for optimum sound quality and system protection. This means you can feel free to crank the volume without much worry of harming your system. However, it is wise to use a little common sense. If you hear any distortion, back off a little. We recommend you do not adjust the gains from the factory settings without first consulting Hoppe Industries.

Please note that your subwoofer will take 20 to 30 hours of play time to fully break in and reach its maximum output. You do not need to do anything different during this break in period. In fact, the more you listen and the louder you turn it up, the quicker you will

reach the maximum potential. Use the equalizer settings in your KMC2 receiver to adjust the bass as needed throughout the break in period.

2.3 Warranty:

Your *Audio Shade* comes equipped with a 1 year limited warranty covering the lights, the stereo equipment, and the fiberglass top. The date of warranty coverage will be determined by the registration date of the warranty card or online warranty registration.

<http://www.motortrike.com/TrikeAccWarranty.aspx>

If the warranty is not registered with Hoppe, the warranty period will begin when the Audio Shade was shipped from Hoppe's factory.

2.4 Care and Maintenance:

Your off-road top does not require any maintenance other than an occasional cleaning. To clean your top, simply hose off or power wash from a distance. If needed, use a mild automotive soap and sponge or brush. Use common sense. Do not use a high pressure power washer up close where it could cut, scar, or force water beyond the design intent of the top, lights, or stereo equipment.

The fuse box for the amplifiers can be accessed by removing the cover plate located on the passenger side rear corner. The fuse box for the radio, light bars, and interior lights can be accessed by removing the cover plate located on the driver side rear corner.

There is also a mini 40 amp ignition relay built into the chassis harness near the battery terminal end of the harness, as shown in Figure 1.



Figure 1: Chassis harness relay.

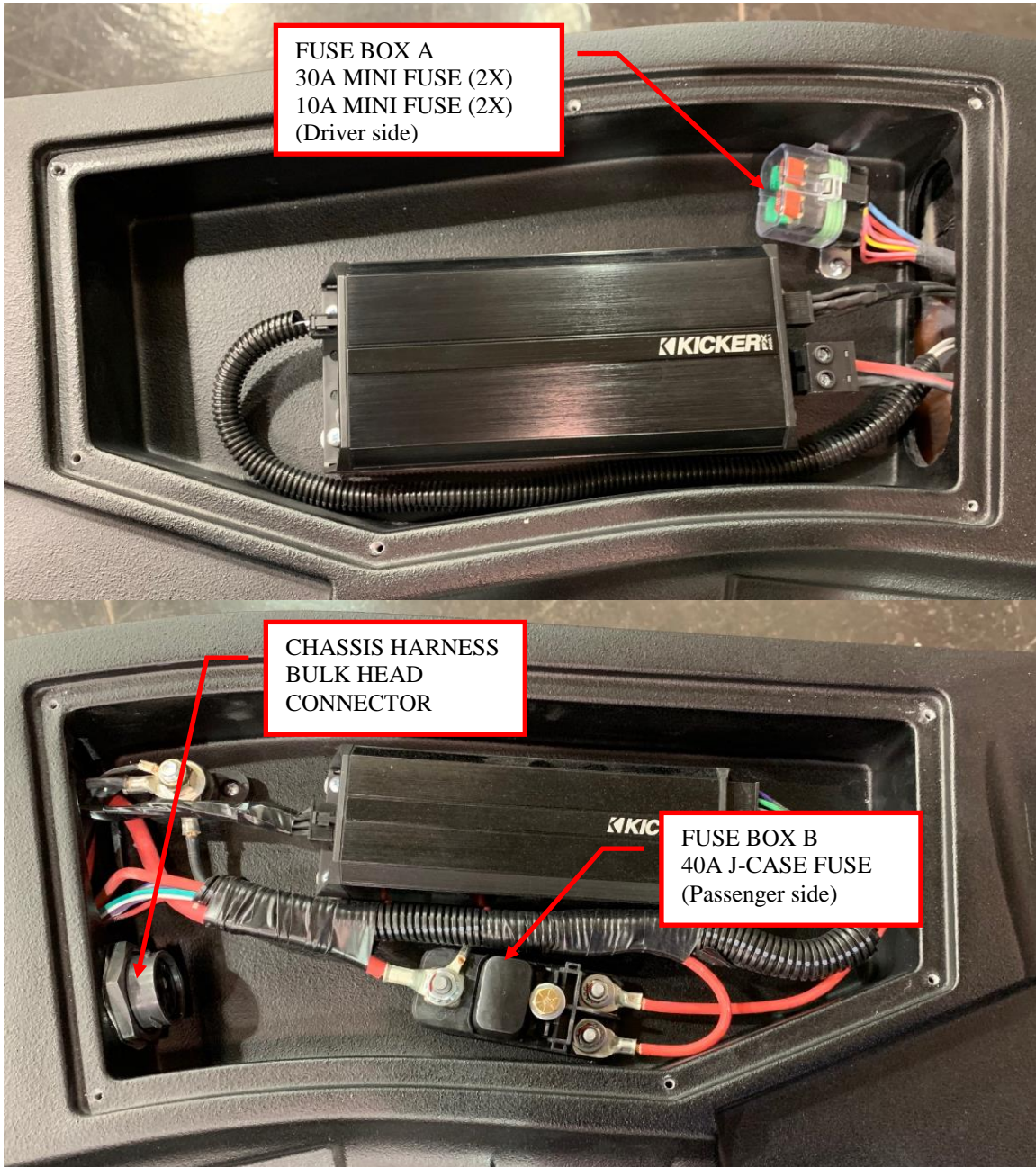

Figure 2: Fuse location.

- Fuse 1 Box A: 30 amp mini fuse for rear light bar
- Fuse 2 Box A: 10 amp mini fuse for interior light
- Fuse 3 Box A: 30 amp mini fuse for front light bar / radio receiver power.
- Fuse 4 Box A: 10 amp mini fuse for illumination / radio receiver ignition.
- Fuse Box B: Each amplifier uses a 40 amp J-Case fuse located under the black plastic cover shown in Figure 2.

2.5 Warnings:

This off-road top adds up to 140 lbs. to your vehicle and is located up high on the roll cage. This increases the vehicles center of gravity and changes the vehicle dynamics and handling characteristics. Use extra caution as you learn the driving characteristics of your vehicles performance with your new off-road top installed. High speed cornering, off camber or side hill, acceleration, and braking performance will be negatively impacted by the weight of the top.

Do not listen to your stereo at an uncomfortable volume for extended periods of time. Potential hearing loss may result.

The driving lights provided with your Audio Shade are blinding to oncoming drivers. These are made for off road use only, and should be turned off when another vehicle is approaching on the trail.

SECTION 3 – Pre-Installation Inspection

Included in your off-road top are the following components:

- Pre-assembled *Audio Shade* off-road top. (All speakers and electronics come preinstalled with interior wire harness.)
- Chassis wire harness.
- Six (6) cage clamps.
- Hardware bag.

If any of the parts are missing, damaged, or you have any questions concerning them, please call Hoppe at (262)-552-2770 Mon-Thur. 8am-5pm CST.

In addition to accounting for all of the parts that you should receive with the top, you should inspect the vehicle in the following ways.

- Ensure that the vehicle is equipped with the factory roll cage, and the roll cage has not been bent out of shape in a roll over.
- Make sure the vehicle does not have any aftermarket accessories that are incompatible with the top. **Note: This top is designed to be compatible with most factory windshields.**
- Make sure the battery is in good condition and holds a charge.
- Make sure the charging system is in good condition.

SECTION 4 – Installation

1. Remove the cage clamps and 3/8”-16 bolts and washers that come pre-installed on the top. Save the hardware for installation. See Figure 3 and Figure 4.

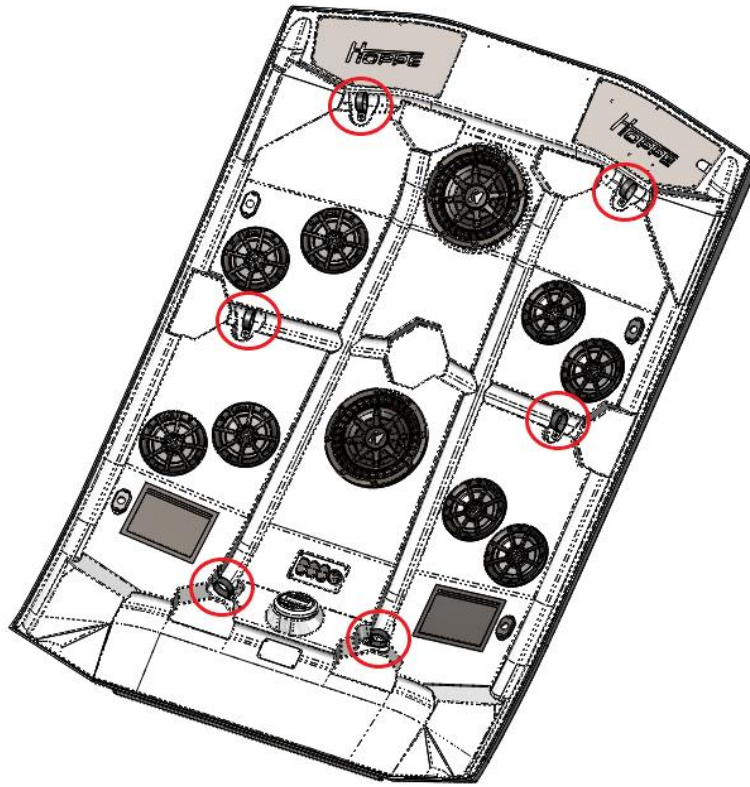

Figure 3: Remove the 6 clamps from the top.

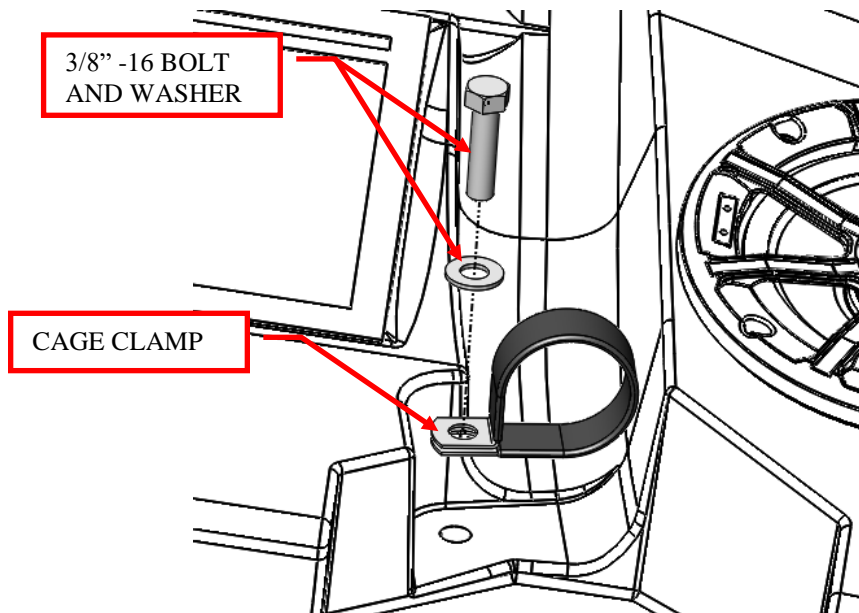

Figure 4: Close up of cage clamp hardware.

2. Spread the clamps by hand and slide them over the cage tubing. Place them on the cage in the approximate locations shown in Figure 5. Note the orientation of the clamp tab. It must line up with the hole, flat against the top, on the correct side of the tubing.

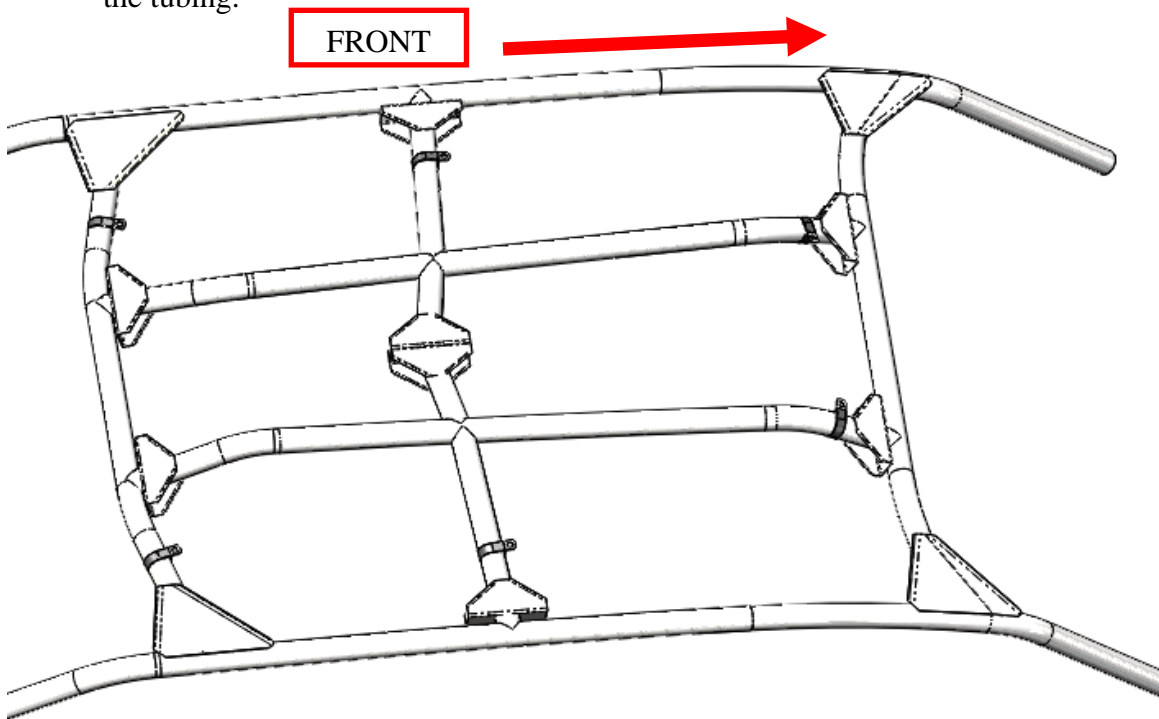

Figure 5: Approximate clamp locations.

3. Using a few assistants, set the *Audio Shade* off-road top on the cage. The top is contoured such that the cage fits inside the grooves on the top. **Note: The top weighs up to 140 lbs. depending on your configuration. Since you will have to lift and reach, it is helpful to have up to 4 people for this step.** See Figure 6.

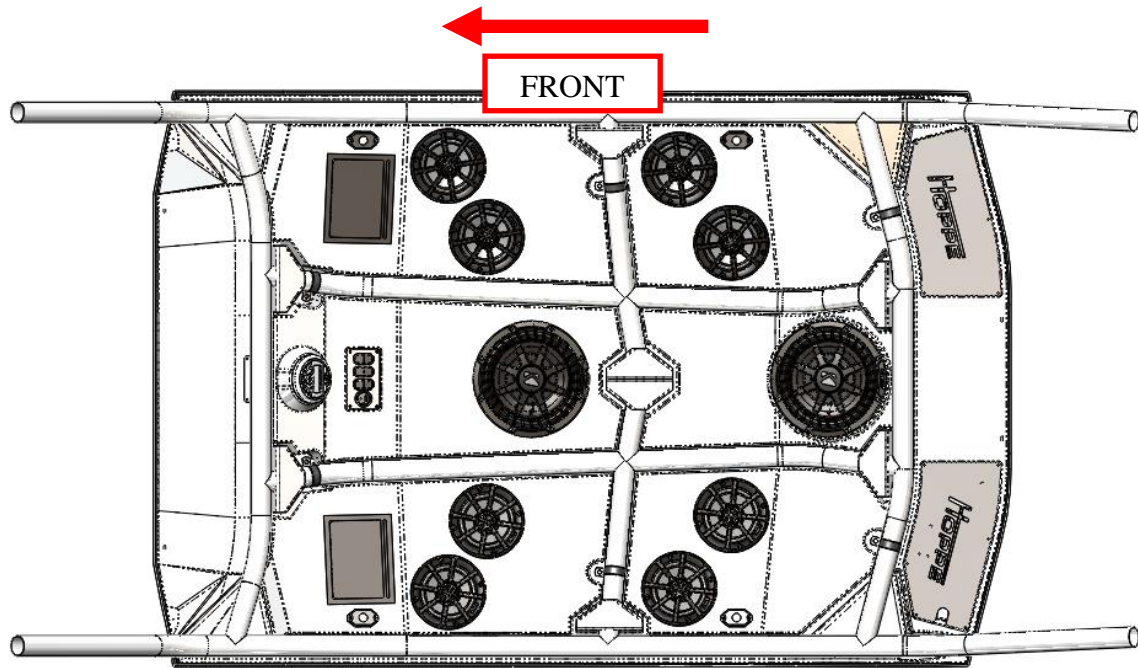

Figure 6: Install the top on the cage.

4. Slide the clamps into position so they line up with the threaded holes in the top. For all 6 clamps, install the 3/8-16 x 1 1/4" bolt with washer through both clamp tabs and into the threaded hole in the top. Use blue Loctite 243 (medium strength) and torque the bolts to 25 ft.*lbs. See Figure 4.
5. Slide the rear passenger's side seat all the way forward to access the battery. Alternatively, you can remove the rear passenger's seat to make accessing the battery easier. There are 4 bolts securing the seat to the cage.
6. Route the chassis wiring harness along the down tube on the passenger's side rear corner of the cage. The ends with the battery terminals and relay block extend through the plastic cage trim, further down the cage, behind the shock, and through the rear seat firewall (shown in Step 7 below). See Figure 7.

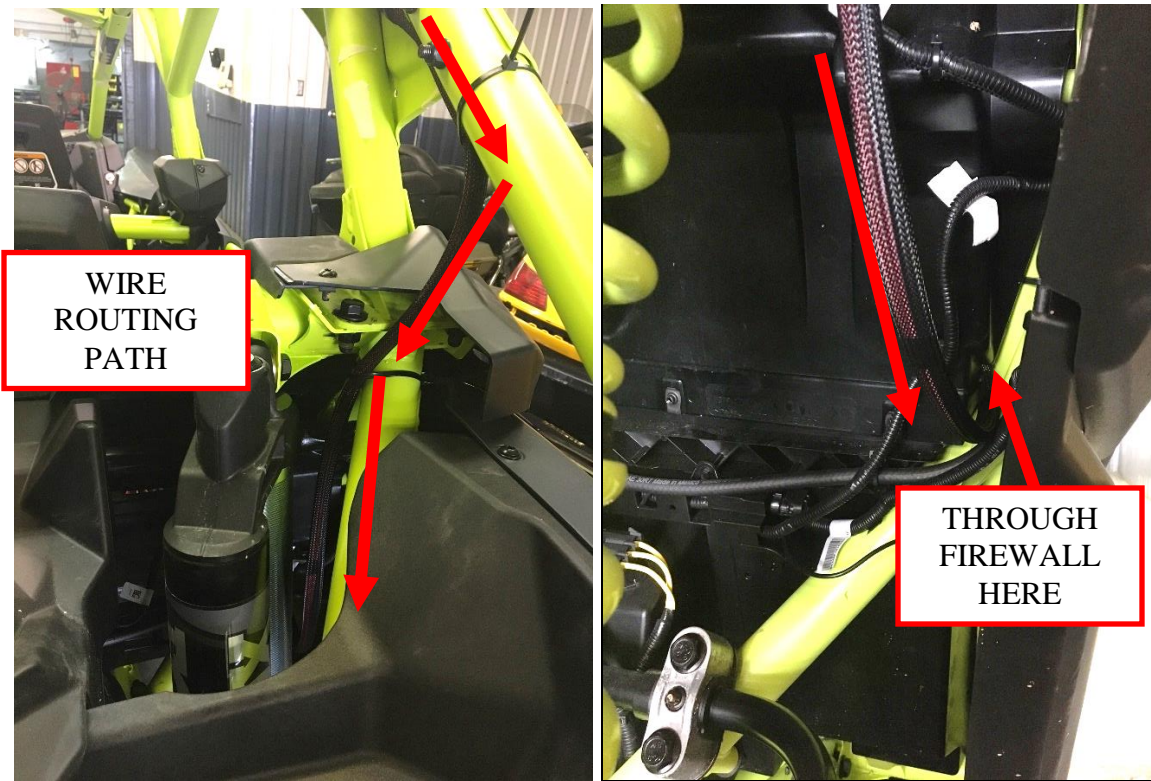

Figure 7: Route the battery cable wiring.

7. To get the relay block and ring terminals through the rear seat firewall, remove the bolts from the inside of the rear firewall (behind the rear passenger seat) as shown in Figure 8. Carefully spread the panels to slide the relay and ring terminals through the firewall. Replace the bolts once the harness is in position and through the opening in the firewall.

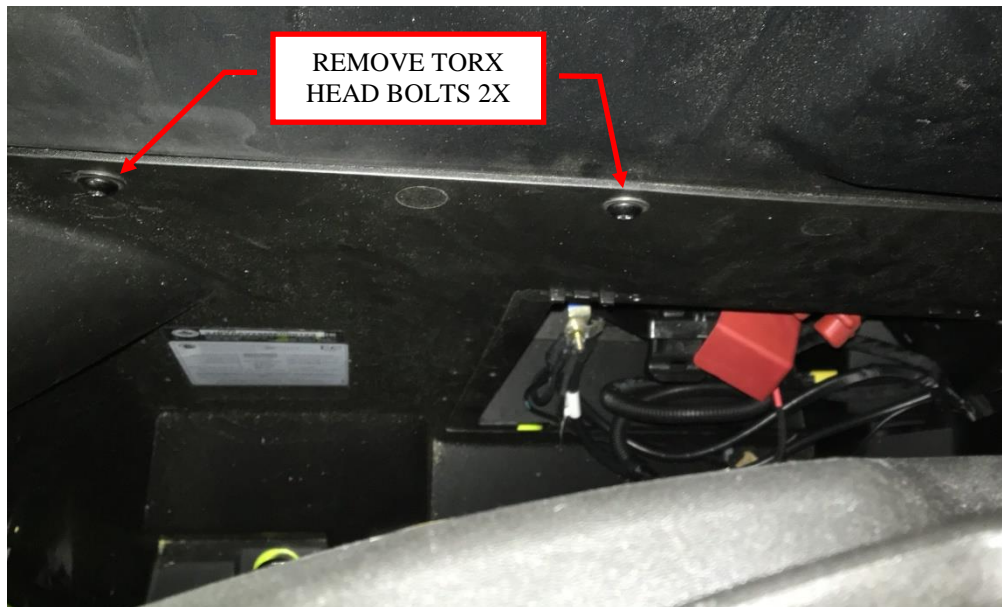

Figure 8: Remove torx bolts in rear firewall.

8. Connect the red power wire to the positive terminal of the battery. Connect the black ground wire to the negative terminal of the battery. Use the supplied ¼" washers and M6 x 1.0 nuts to clamp the cables on top of the existing battery cables. See Figure 9.

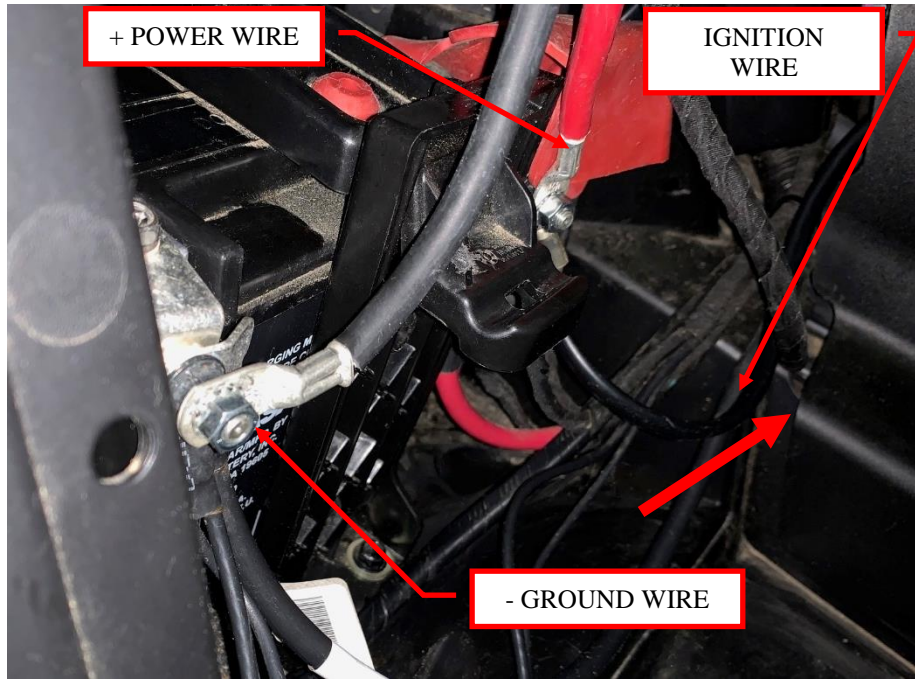

Figure 9: Attach the power wires.

9. Remove the side panel of the center console to access the ignition powered accessory terminal. The panel is removed by carefully prying the side wall tabs outwards, carefully prying the top tab downward, and then lifting off of the lower tabs. See Figure 10.

Note: This step is easier with the passenger seat removed. There are 4 bolts securing the seat to the cage.

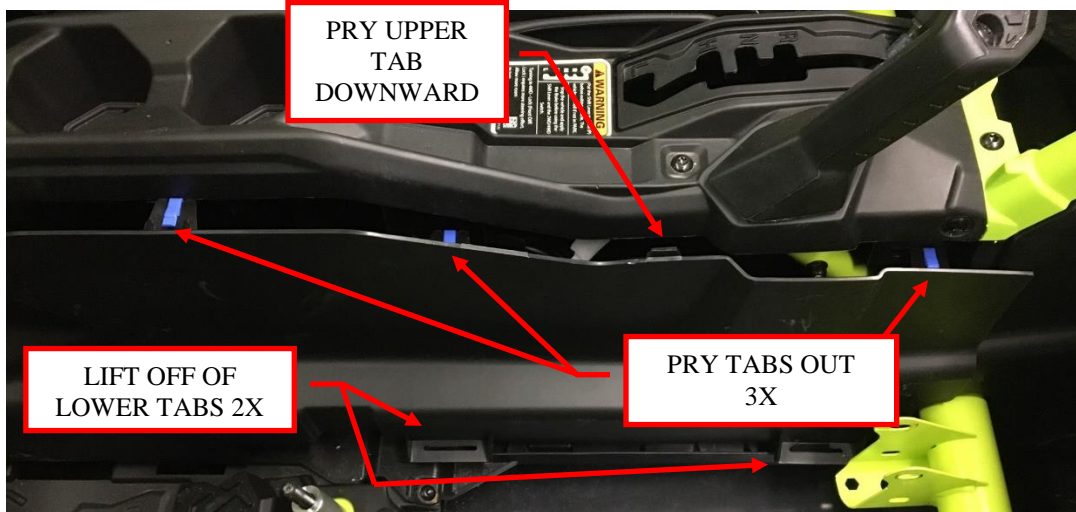

Figure 10: Remove the center console side panel.

10. Route the ignition wire from behind the rear passenger seat (near the area where you made the battery connections in Figure 9), into the opening by the rear passenger seat floor, and into the front center console. See Figure 11.

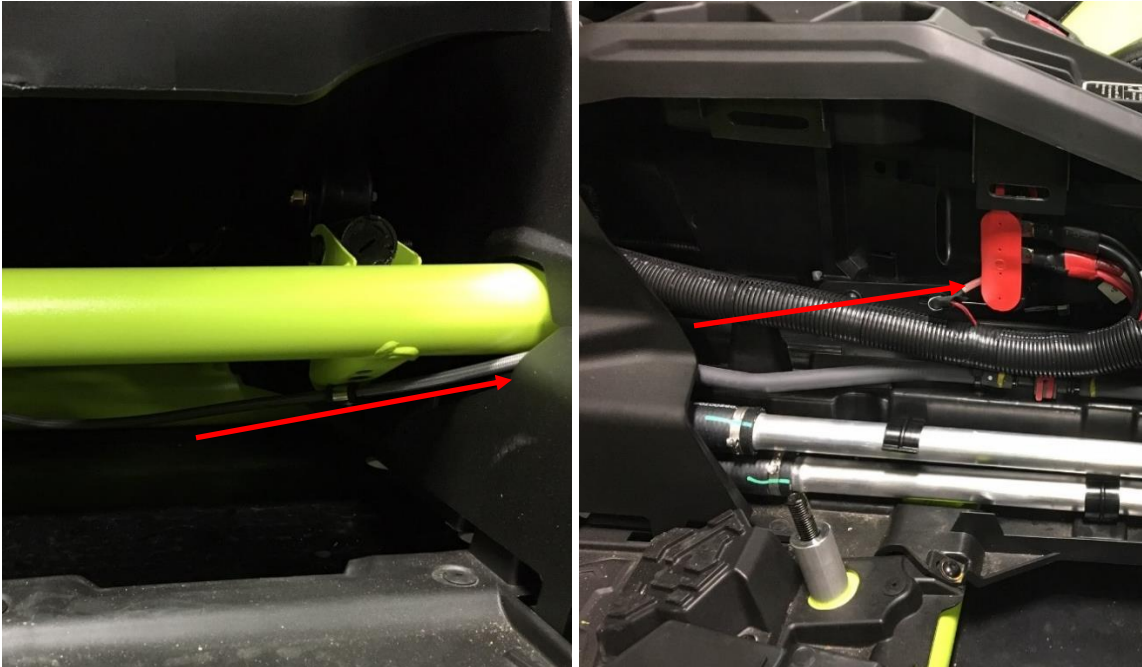

Figure 11: Ignition wire routing path.

11. Remove the protective rubber cover and connect the pink ignition wire to the terminal labeled “ACC” using the small washer and supplied M6 x 1.0 nut. Replace the rubber cover. See Figure 12.

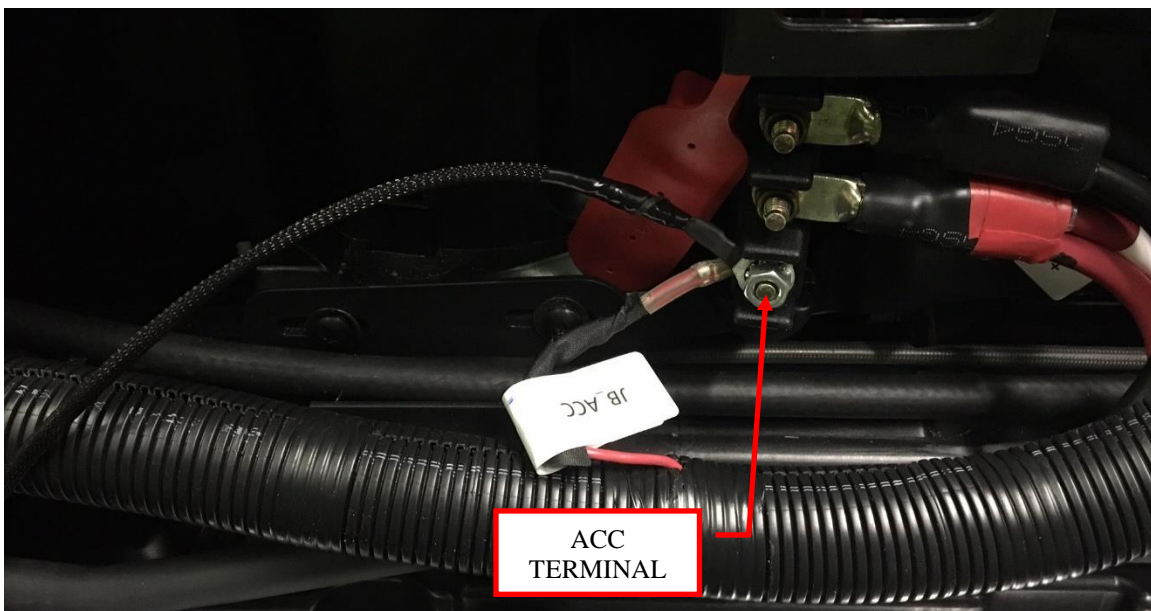

Figure 12: Connect to the ACC terminal.

12. Carefully replace the side panel of the center console, and reinstall the front passenger seat, if removed.
13. The chassis harness / bulk head connector should already be in place when the top ships. However, if you have previously removed the top or need to, it can be disconnected to leave the chassis harness in place.

To plug it back in, line up the terminals on the chassis harness connector with the bulk head connector located under the passenger side amp cover. Plug the connector in and rotate the ¼ turn collar to lock the connector together. See Figure 13.



Figure 13: Align connector terminals and rotate 1/4 turn.

14. Use zip ties to secure the chassis harness to the roll cage. Make sure the wires are secured away from any moving suspension components or hot exhaust. Work your way from the bulk head connector on the top to the battery.
15. You are now ready to enjoy the music, lighting, and shade provided by your *Audio Shade* off-road top. Basic operation works as follows:
 - Turn the vehicle ignition switch on to power up the stereo system.
 - Press the source button on the stereo receiver to select the input source from AM/FM radio, Bluetooth, or Auxiliary.
 - Press and hold the menu button to access the Device Settings menu.
 - Use the Volume knob to change the values for each setting, and press it to confirm the setting.
 - Press and hold the Volume knob to access the Audio Settings menu.
 - Use the Volume knob to change the values for each setting, and press it to confirm the setting.
 - The front and rear light bars can be used with or without the vehicle's ignition switch on. Press the toggle switches to activate each component.

Warning: extended use of the light bars without the vehicle's charging system functioning will deplete the battery and the engine may not start.

- To control the interior light color or make them dance to the music, download the Bluetooth app to your iOS or Android device. The app information is included with your Audio Shade and is located in the zipper pocket.

To learn about the more advance features and operation of your stereo, visit the Kicker website links found in SECTION 2 – About your Audio Shade Top of this document.

Thank you for choosing Hoppe *Audio Shade* off-road top for your Can-Am Maverick X3 Max UTV. We hope you enjoy your new sound system, top, and lighting. We invite you, in your travels, to stop by our manufacturing plant in Troup, Texas, for a factory tour and to meet the people who designed and manufactured your Audio Shade off-road top. This will also give you an opportunity to check out our sister companies



and our extensive line of trike conversions, automotive, motorcycle, and power sports accessories.

We believe you will be impressed by what you witness and the people you will meet.