



**INSTALLATION INSTRUCTIONS / OWNER'S MANUAL:
AUDIO MINI
OFF-ROAD SOUND SYSTEM FOR POLARIS RZR / RZR 4 MODELS**

www.hoppeindustries.com
22667 FM 15 Troup, TX 75789
(262) 552-2770

Thank you for choosing the Hoppe *Audio Mini* off-road sound system. We hope you enjoy the off-road sound system, and we ask that you follow these instructions very closely. Doing so will save you time and ensure that your experience with the new *Audio Mini* is a positive one.

We strongly suggest that you read the complete instructions before beginning the installation process to eliminate the possibility of performing unnecessary work.

Having a safe and clean environment and using the proper tools is essential for a successful installation.

It is critical that proper eye wear, ear protection, and protective clothing is worn throughout the top installation.

When you receive your *Audio Mini* off-road sound system, please check to ensure that all parts and hardware are included. If there are any parts missing or if you have any questions concerning the system at this time call Hoppe at (262)-552-2770 Mon-Thur. 8am-5pm CST, or you can email us at tech@hoppeindustries.com.

Hoppe reserves the right to change specifications, equipment, or designs at any time without notice and without incurring obligation.

TABLE OF CONTENTS

SECTION 1 – <i>Tools Required</i>	4
SECTION 2 – <i>About your Audio Mini sound system</i>	4
2.1 Applicable Year Models:	4
2.2 Audio Equipment Details:.....	4
2.3 Warranty:	5
2.4 Care and Maintenance:	5
2.5 Warnings:.....	6
SECTION 3 – <i>Pre-Installation Inspection</i>	7
SECTION 4 – <i>Installation</i>	8



SECTION 1 – Tools Required

- Socket wrench set
- Combination wrench set
- Wire cutters

In addition to the above items, you may need shop supplies such as electrical tape, wire ties, thread locking compound, etc.

SECTION 2 – About your Audio Mini sound system

2.1 Applicable Year Models:

This *Audio Mini* off-road sound system is designed to fit the following Polaris RZR / RZR 4 models:

- 2015-2021 RZR 900 through 1000 (all versions excluding Turbo S, PRO XP, and 2021 Trail models)
- 2014 RZR XP 900
- 2014-2021 RZR 4 900 through 1000 (all versions excluding Turbo S and PRO XP)
- All versions means it includes sub models such as Turbo, Dynamix, Fox, EPS, XP, High Lifter, Premium, Trails and Rocks, LE, and Sport.
- Does NOT fit Turbo S, PRO XP, or any of the above names combined with Turbo S or PRO XP models.
- This system is compatible with most front full windshields and roofs.
- Accessories that mount overhead near the front of the roll cage such as rear view mirrors, wiper motors, etc. may not be compatible or may require modification. Contact Hoppe customer service for questions.

2.2 Audio Equipment Details:

Your *Audio Mini* off-road sound system is powered by  using their marine series audio equipment. This equipment is designed to function in all weather conditions with an IPX6 water resistance (powerful water jet) rating. The stereo is specifically engineered to provide excellent sound quality and volume in an open air environment so you can enjoy your music on the go.

To learn more details about your stereo system, you can access product information and manuals for the stereo equipment here:

- KMC2 receiver: <https://www.kicker.com/46KMC2>
- Speakers: <https://www.kicker.com/41KM604W>

You can feel free to crank up the volume without much worry of harming your system. However, it is wise to use a little common sense. If you hear any distortion, back off a little.

Use the equalizer settings in your KMC2 receiver to adjust the settings to your preferences.

2.3 Warranty:

Your *Audio Mini* comes equipped with a 1 year limited warranty covering the light, the stereo equipment, and the fiberglass enclosure. The date of warranty coverage will be determined by the registration date of the warranty card or online warranty registration.

<http://www.motortrike.com/TrikeAccWarranty.aspx>

If the warranty is not registered with Hoppe, the warranty period will begin when the Audio Mini was shipped from Hoppe's factory.

2.4 Care and Maintenance:

Your off-road sound system does not require any maintenance other than an occasional cleaning. To clean your audio system, simply hose off or power wash from a distance. If needed, use a mild automotive soap and sponge or brush. Use common sense. Do not use a high pressure power washer up close where it could cut, scar, or force water beyond the design intent of the enclosure, light, or stereo equipment.

There is an inline fuse, close to the end of the chassis harness where it connects to the terminal posts. It can be accessed by pulling the cap off of the fuse holder. There is also a mini 40 amp ignition relay built into the chassis harness next to the inline fuse. See Figure 1.

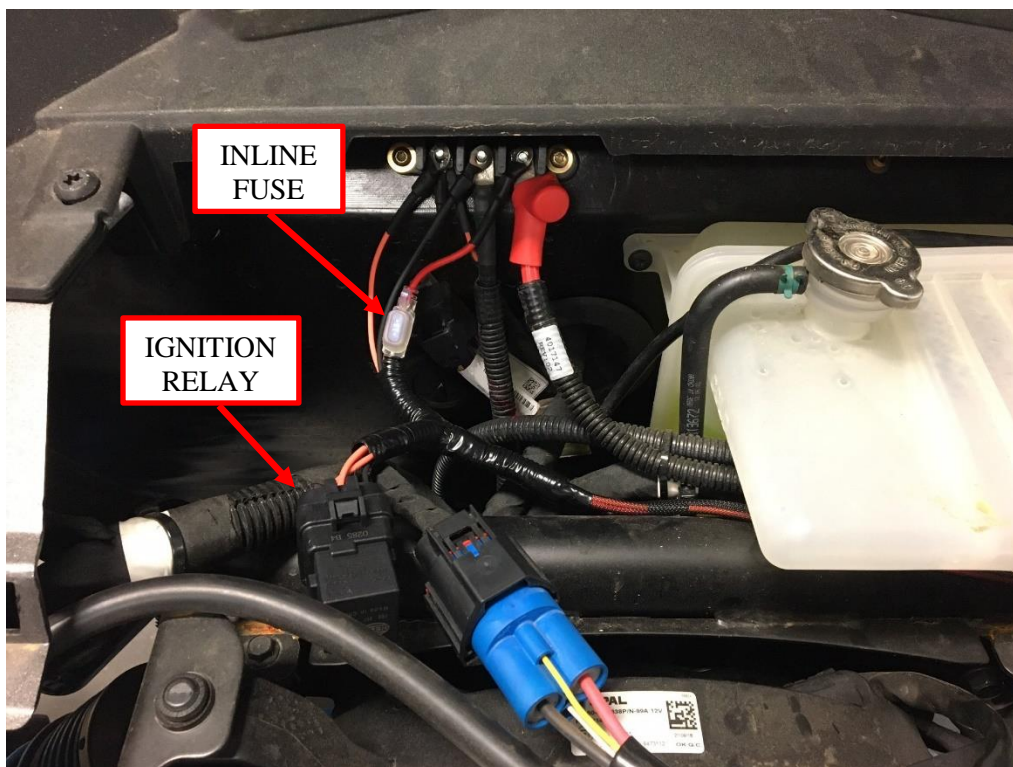

Figure 1: Fuse location.



- Fuse 1: 15 amp mini fuse for light / radio receiver power.

2.5 Warnings:

This off-road system adds up to 25 lbs. to your vehicle and is located up high on the roll cage. This increases the vehicle's center of gravity and changes the vehicle dynamics and handling characteristics. Use extra caution as you learn the driving characteristics of your vehicle with your new off-road sound system installed. High speed cornering, off camber or side hill, acceleration, and braking performance will be negatively impacted by the weight of the sound system.

Do not listen to your stereo at an uncomfortable volume for extended periods of time. Potential hearing loss may result.

SECTION 3 – Pre-Installation Inspection

Included in your off-road sound system are the following components:

- Pre-assembled *Audio Mini* off-road sound system (All speakers and electronics come preinstalled with interior wire harness.)
- Chassis wire harness
- Mounting brackets
- Hardware bag
- Zip ties

If any of the parts are missing, damaged, or you have any questions concerning them, please call Hoppe at (262)-552-2770 Mon-Thur. 8am-5pm CST.

In addition to accounting for all of the parts that you should receive with the top, you should inspect the vehicle in the following ways.

- Ensure that the vehicle is equipped with the factory roll cage, and the roll cage has not been bent out of shape in a roll over.
- Make sure the vehicle does not have any aftermarket accessories that are incompatible with the top.
- Make sure the battery is in good condition and holds a charge.
- Make sure the charging system is in good condition.

SECTION 4 – Installation

1. If you have a roof installed, it will need to be removed for the installation of your *Audio Mini*. Remove the roof, and then remove the screw shown in Figure 2 to gain access to the front cross member bolts.



Figure 2: Remove screw to access cross member bolt.

2. Remove the factory bolt from the driver's side of the front cross member as indicated in Figure 3. The bolt will be reused.

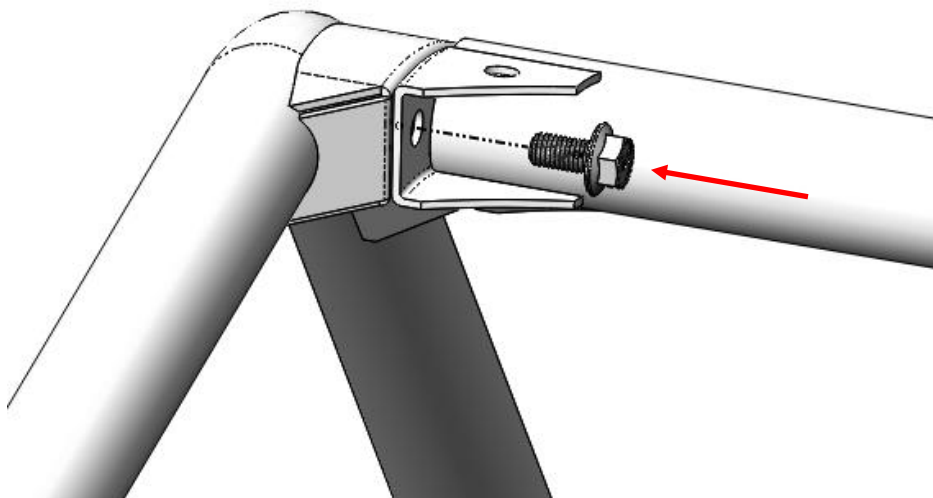

Figure 3: Remove the factory cross member bolt.

3. Place the provided loop clamps in the approximate mounting locations on the outside roll bars. The *Audio Mini* brackets will rest on the loop clamps and be tightened in the following steps. See Figure 4.

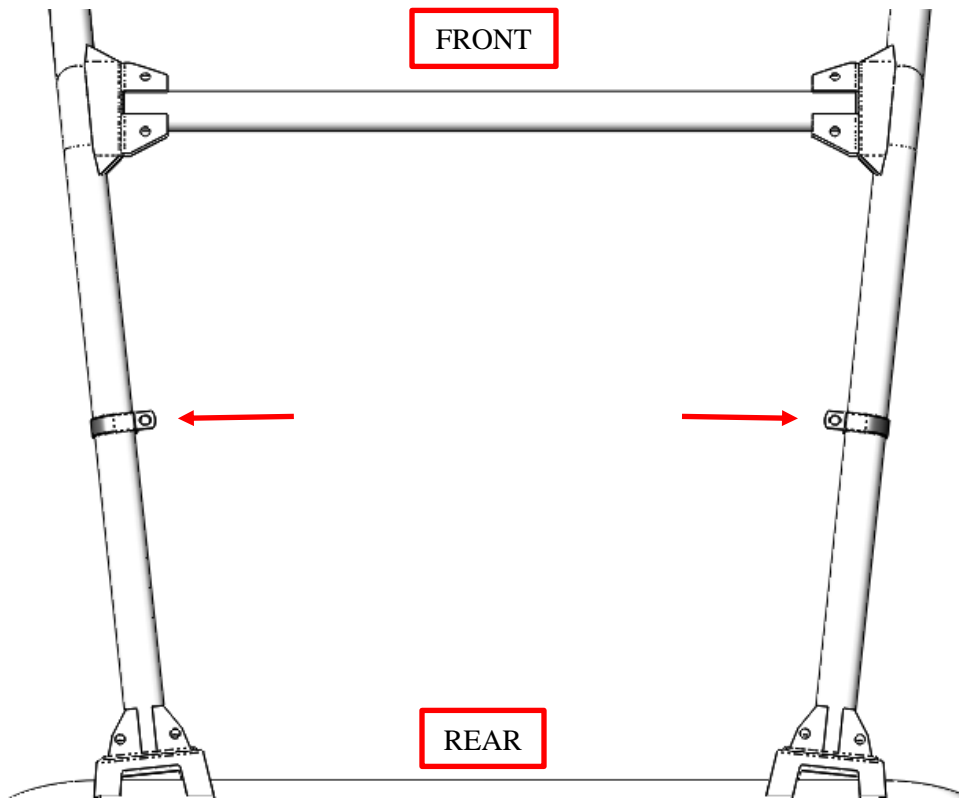

Figure 4: Approximate locations of the loop clamps.

4. Place the driver's side bracket on the inside of the cross member. Use the factory bolt and loosely tighten it until the bracket is secured to the loop clamp in the following steps. Verify correct orientation of the mounting bracket. See Figure 5.
Note: Driver side bracket shown. (Passenger side similar)

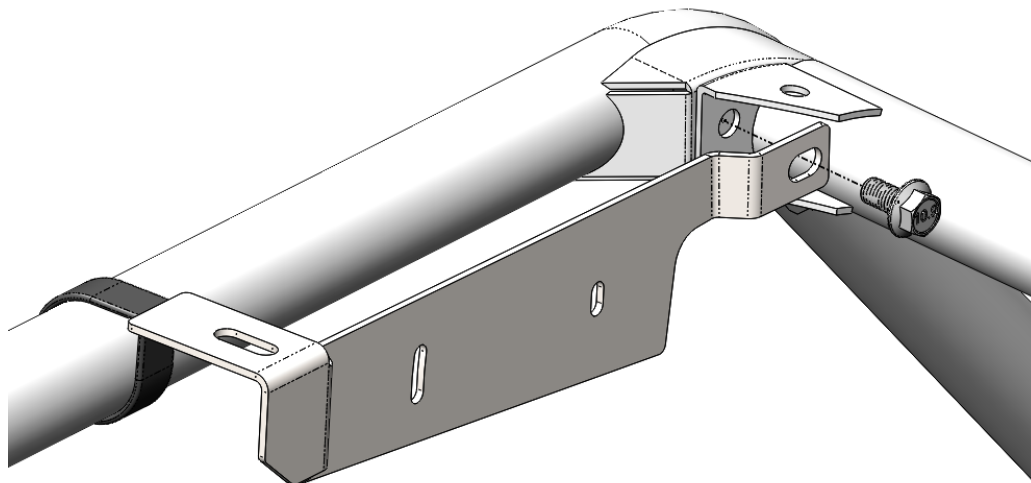

Figure 5: Mounting location of the *Audio Mini* bracket.

5. Use the supplied 3/8"-16 x 1" bolts, washers, and nylock nuts to secure the loop clamp to the mounting bracket. Tighten both the loop clamp bolt and the front cross member bolt to secure to bracket to the roll cage. See Figure 6.

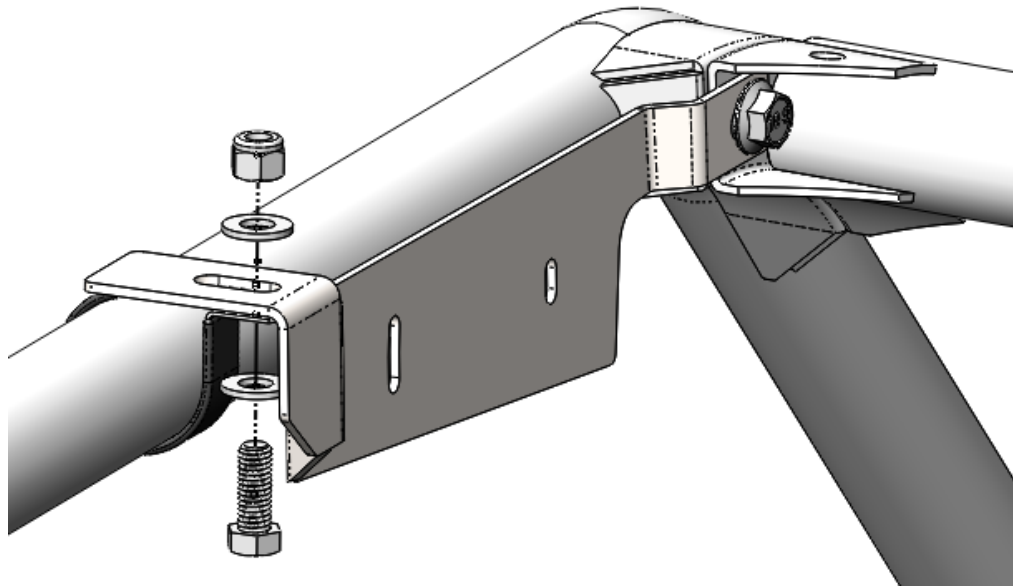

Figure 6: Hardware for mounting the loop clamps to the brackets.

6. Repeat Steps 1, 2, 4, and 5 for the passenger side bracket.
7. Remove the radiator hood access panel from the front of the vehicle by rotating the ¼ turn clips, lifting, and sliding towards the front of the vehicle. See Figure 7.



Figure 7: Remove the radiator hood access panel.

8. Remove the Torx screw on top of the driver's side dash by the front frame tube. The harness will route under this panel in later steps. See Figure 8.



Figure 8: Remove the dash Torx screw.

9. Install the chassis harness reusing the factory nuts on the terminal posts. Connect the orange ignition wire to the terminal post labeled "ACC", the black ground wire to the black (negative) terminal post, and the red power wire to the red (positive) terminal post. Be sure to connect the harness wires with any factory cables or wires, and retighten the factory hardware. Run the connector under the coolant tank, along the frame tube, toward the driver's front fender well. See Figure 9.

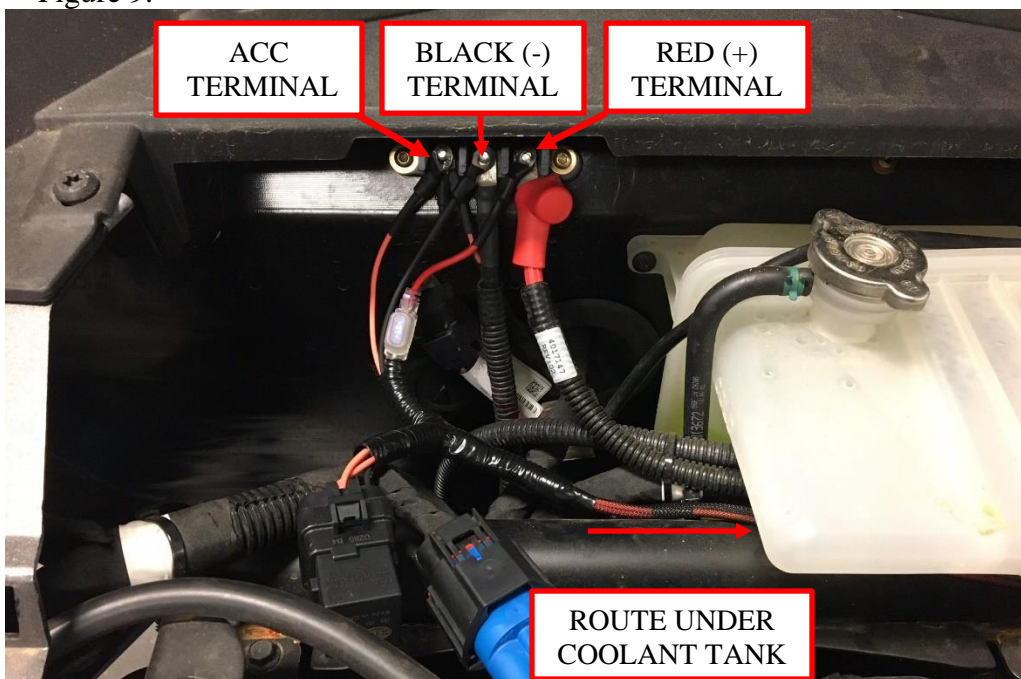

Figure 9: Connect the harness to the terminal posts.

10. Route the mating connector from under the coolant tank along the frame to the opening in the driver side front fender well. See Figure 10 and Figure 11.

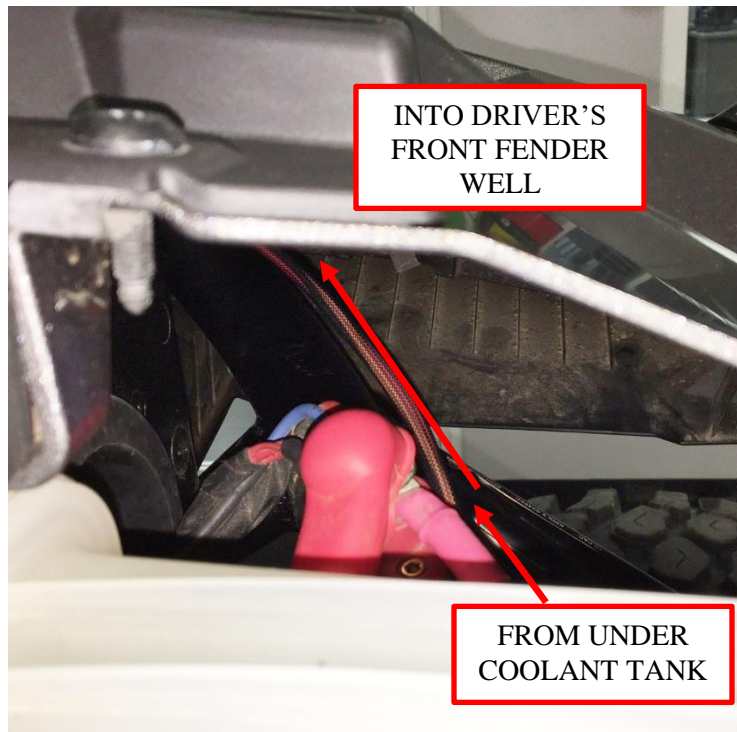

Figure 10: Chassis harness routing along frame into fender well.



Figure 11: Chassis harness routing in driver's front fender well.

11. Continue routing the harness under the driver's side dash, and then route the harness between the dash panels up toward the driver's front frame tube. Gently push the top dash panel upwards to push the connector through, pulling the slack from the harness. See Figure 12 and Figure 13.

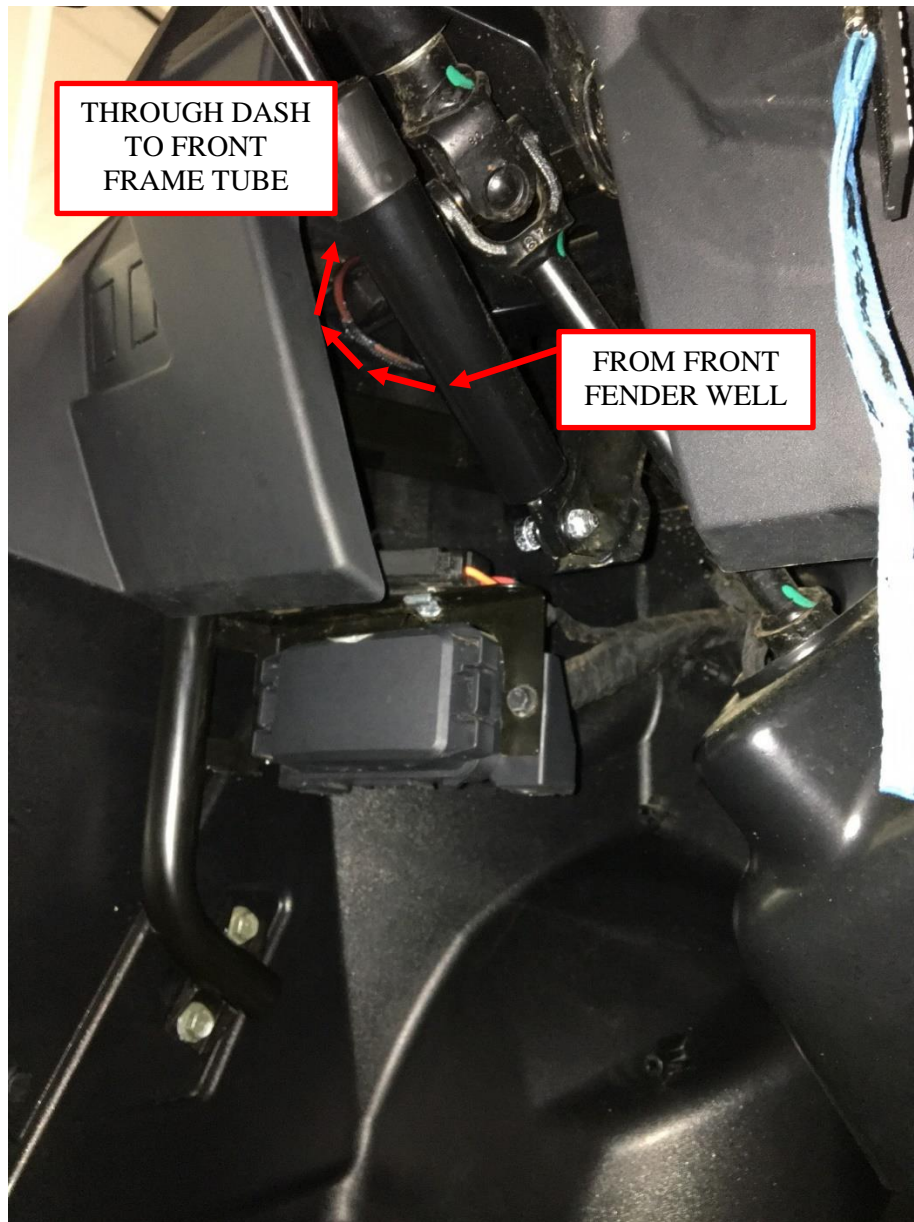

Figure 12: Harness routing path from fender well through the dash.



Figure 13: Harness routing between dash panels.

12. Route the harness up the front driver's frame tube to the front cross member, as shown in Figure 14. Loosely zip tie the harness to the frame tube, waiting to fully tighten them until the Audio Mini is tightened in the desired position.

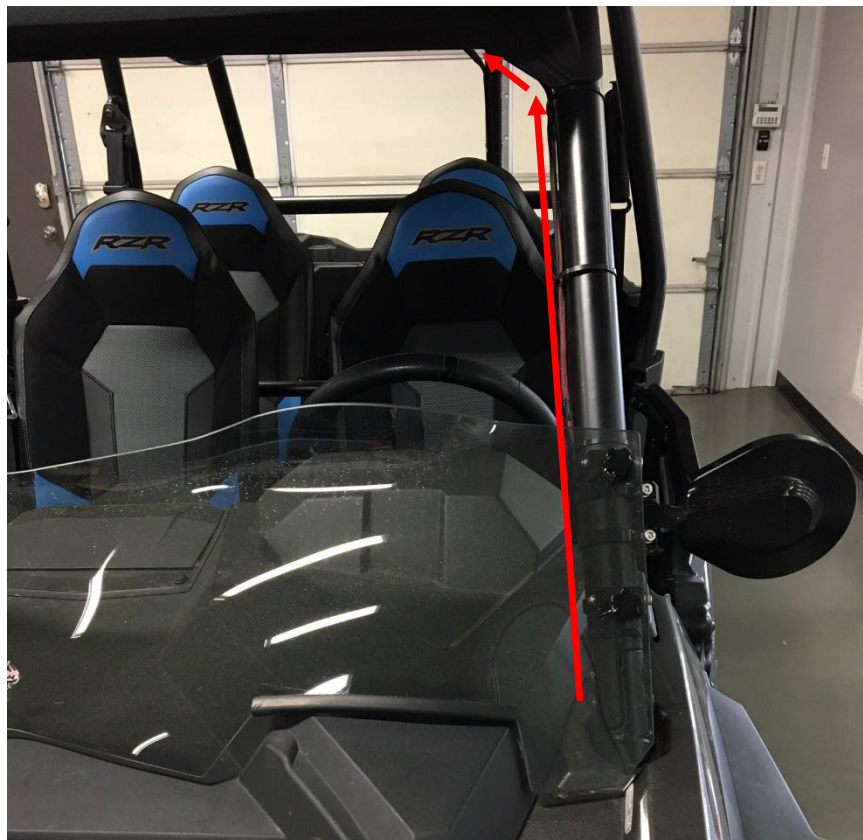

Figure 14: Harness route up the front frame tube.

13. Using an assistant, connect the two mating connectors and hang the *Audio Mini* off-road sound system on the brackets using the supplied ¼"-20 bolts and washers (loosely tightened). **Note: The sound system weighs up to 25 lbs. Since you will have to lift and bolt each end, it is helpful to have an assistant for this step. Note: The harness connector will not fit between the frame and the Audio Mini once installed, so it is important to follow this step closely to not repeat work.** See Figure 15 and Figure 16.

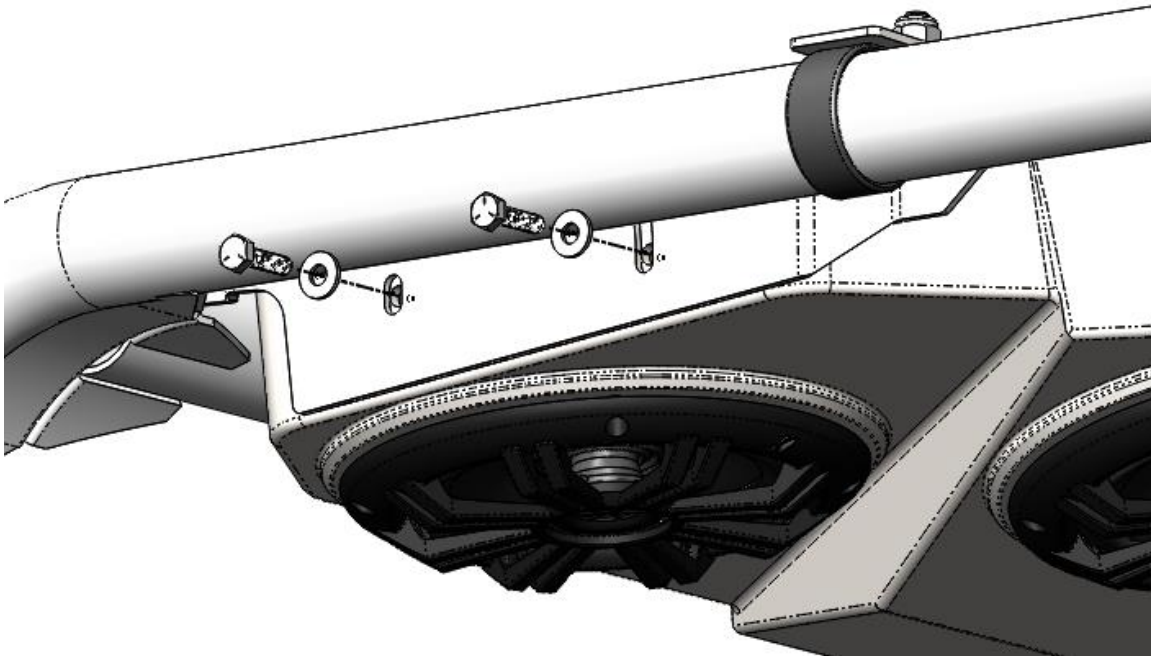

Figure 15: Install the ¼"-20 bolts and washers to mount the Audio Mini to the brackets.

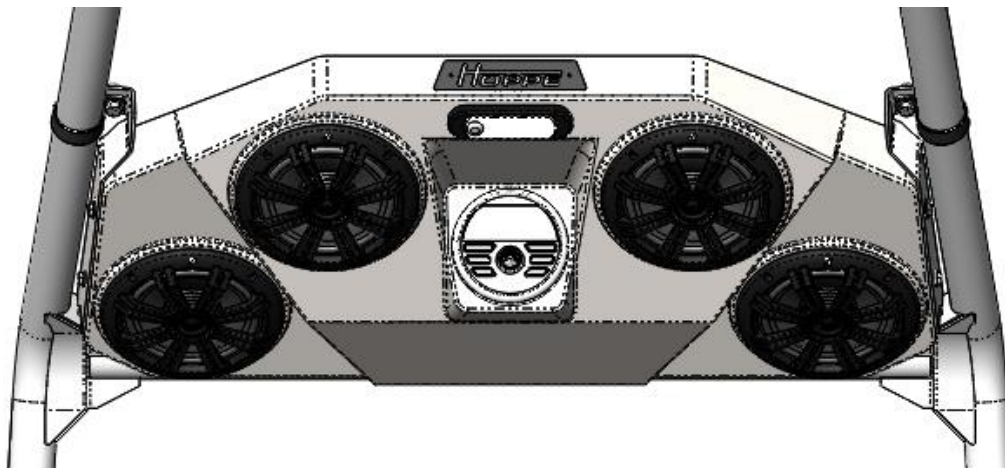

Figure 16: Loosely install the sound system on the mounting brackets.

14. Tighten the 4 mounting bracket bolts after achieving the desired viewing position relative to the roof or roll cage. A slot in the front hole allows up-down movement, while the rear hole allows the *Audio Mini* to pivot to achieve your desired viewing position. See Figure 17.

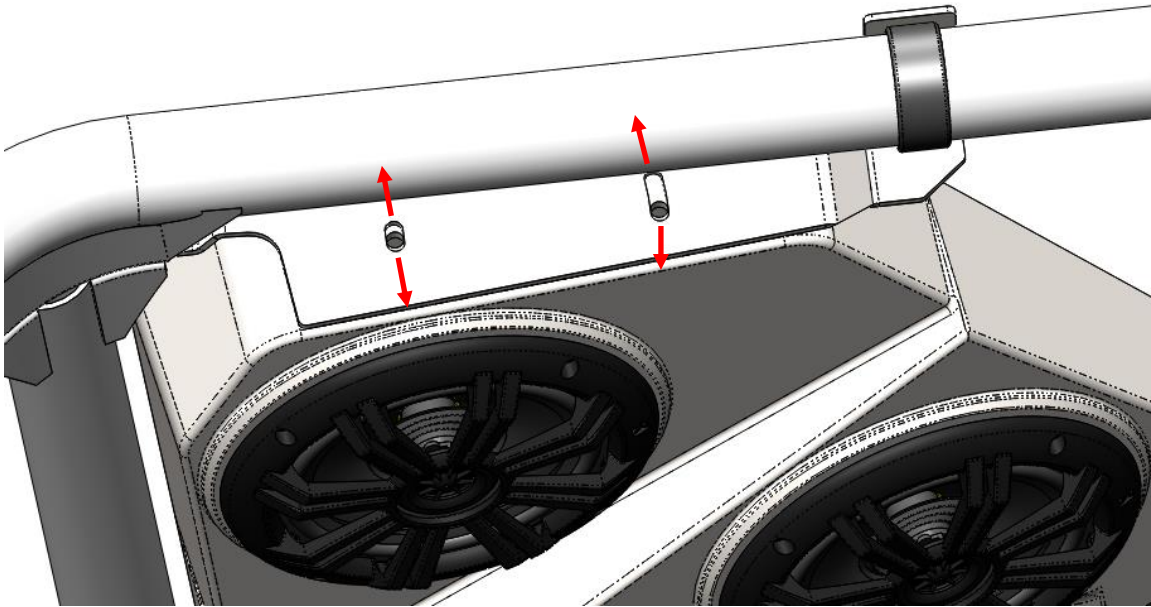

Figure 17: Adjustable positioning of the Audio Mini.

15. Tighten all zip ties, and secure the chassis harness to the roll cage under the hood. Make sure the wires are secured away from any moving suspension components and the radiator fan under the hood.
16. Reinstall the hood and Torx screws. See Figure 2, Figure 7, and Figure 8. Reinstall your roof if it was removed.
17. You are now ready to enjoy the music and lighting provided by your *Audio Mini* off-road sound system. Basic operation works as follows:
 - Turn the vehicle ignition switch on to power up the stereo system. (You must press the power button for first time connections or if the power was previously turned off manually.)
 - Press the source button on the stereo receiver to select the input source from AM/FM radio or Bluetooth.
 - Press and hold the menu button to access the Device Settings menu.
 - Use the Volume knob to change the values for each setting, and press it to confirm the setting.
 - Press and hold the Volume knob to access the Audio Settings menu.
 - Use the Volume knob to change the values for each setting, and press it to confirm the setting.
 - The dome light can be used with or without the vehicle's ignition switch on. Press the on/off switch to activate the light. **Warning: Extended use of the dome light or stereo without the vehicle's charging system functioning will deplete the battery and the engine may not start.**

To learn about the more advanced features and operation of your stereo, visit the Kicker website links found in SECTION 2 – About your Audio Mini sound system of this document.

Thank you for choosing the Hoppe *Audio Mini* off-road sound system for your Polaris RZR UTV. We hope you enjoy your new sound system and lighting. We invite you, in your travels, to stop by our manufacturing plant in Troup, Texas, for a factory tour and to meet the people who designed and manufactured your *Audio Mini* off-road sound system. This will also give you an opportunity to check out our sister companies



and our extensive line of trike conversions, automotive, motorcycle, and power sports accessories.

We believe you will be impressed by what you witness and the people you will meet.