



**INSTALLATION INSTRUCTIONS / OWNER'S MANUAL:
AUDIO MINI
OFF-ROAD SOUND SYSTEM FOR HONDA PIONEER 1000 / PIONEER 1000-5
MODELS**

www.hoppeindustries.com
22667 FM 15 Troup, TX 75789
(262) 552-2770

Thank you for choosing the Hoppe *Audio Mini* off-road sound system. We hope you enjoy the off-road sound system, and we ask that you follow these instructions very closely. Doing so will save you time and ensure that your experience with the new *Audio Mini* is a positive one.

We strongly suggest that you read the complete instructions before beginning the installation process to eliminate the possibility of performing unnecessary work.

Having a safe and clean environment and using the proper tools is essential for a successful installation.

It is critical that proper eye wear, ear protection, and protective clothing is worn throughout the top installation.

When you receive your *Audio Mini* off-road sound system, please check to ensure that all parts and hardware are included. If there are any parts missing or if you have any questions concerning the system at this time call Hoppe at (262)-552-2770 Mon-Thur. 8am-5pm CST or Friday 8am -12pm CST. Or you can email us at tech@hoppeindustries.com.

Hoppe reserves the right to change specifications, equipment, or designs at any time without notice and without incurring obligation.

TABLE OF CONTENTS

SECTION 1 – <i>Tools Required</i>	4
SECTION 2 – <i>About your Audio Mini sound system</i>	4
2.1 Applicable Year Models:	4
2.2 Audio Equipment Details:.....	4
2.3 Warranty:	5
2.4 Care and Maintenance:	5
2.5 Warnings:.....	6
SECTION 3 – <i>Pre-Installation Inspection</i>	7
SECTION 4 – <i>Installation</i>	8



SECTION 1 – Tools Required

- Socket wrench set
- Combination wrench set
- Wire cutters

In addition to the above items, you may need shop supplies such as electrical tape, wire ties, thread locking compound, etc.

SECTION 2 – About your Audio Mini sound system

2.1 Applicable Year Models:

This *Audio Mini* off-road sound system is designed to fit the following Pioneer 1000/ Pioneer 1000-5 models:

- 2016-2022 Pioneer 1000 (all versions)
- 2016-2022 Pioneer 1000-5 (all versions)
- 2023 Pioneer 1000-6 (all versions)
 - All versions means it includes sub models such as Deluxe, Limited Edition, and Deluxe Crew editions.
- This system is compatible with most front windshields (Full and Two-Piece Poly and Full Glass) and roofs.
- Accessories that mount overhead near the front of the roll cage such as rear view mirrors, wiper motors, etc. may not be compatible or may require modification. Contact Hoppe customer service for questions.

2.2 Audio Equipment Details:

Your *Audio Mini* off-road sound system is powered by  using their marine series audio equipment. This equipment is designed to function in all weather conditions with an IPX6 water resistance (powerful water jet) rating. The stereo is specifically engineered to provide excellent sound quality and volume in an open air environment so you can enjoy your music on the go.

To learn more details about your stereo system, you can access product information and manuals for the stereo equipment here:

- KMC2 receiver: <https://www.kicker.com/46KMC2>
- Speakers: <https://www.kicker.com/41KM604W>

You can feel free to crank up the volume without much worry of harming your system. However, it is wise to use a little common sense. If you hear any distortion, back off a little.

Use the equalizer settings in your KMC2 receiver to adjust the settings to your preferences.

2.3 Warranty:

Your *Audio Mini* comes equipped with a 1 year limited warranty covering the light, the stereo equipment, and the enclosure. The date of warranty coverage will be determined by the registration date of the warranty card or online warranty registration.

<http://www.motortrike.com/TrikeAccWarranty.aspx>

If the warranty is not registered with Hoppe, the warranty period will begin when the Audio Mini was shipped from Hoppe's factory.

2.4 Care and Maintenance:

Your off-road sound system does not require any maintenance other than an occasional cleaning. To clean your audio system, simply hose off or power wash from a distance. If needed, use a mild automotive soap and sponge or brush. Use common sense. Do not use a high pressure power washer up close where it could cut, scar, or force water beyond the design intent of the enclosure, light, or stereo equipment.

There is an inline fuse, close to the end of the chassis harness where it connects to the battery. It can be accessed by pulling the cap off of the fuse holder. There is also a mini 40-amp ignition relay built into the chassis harness next to the inline fuse. See Figure 1.

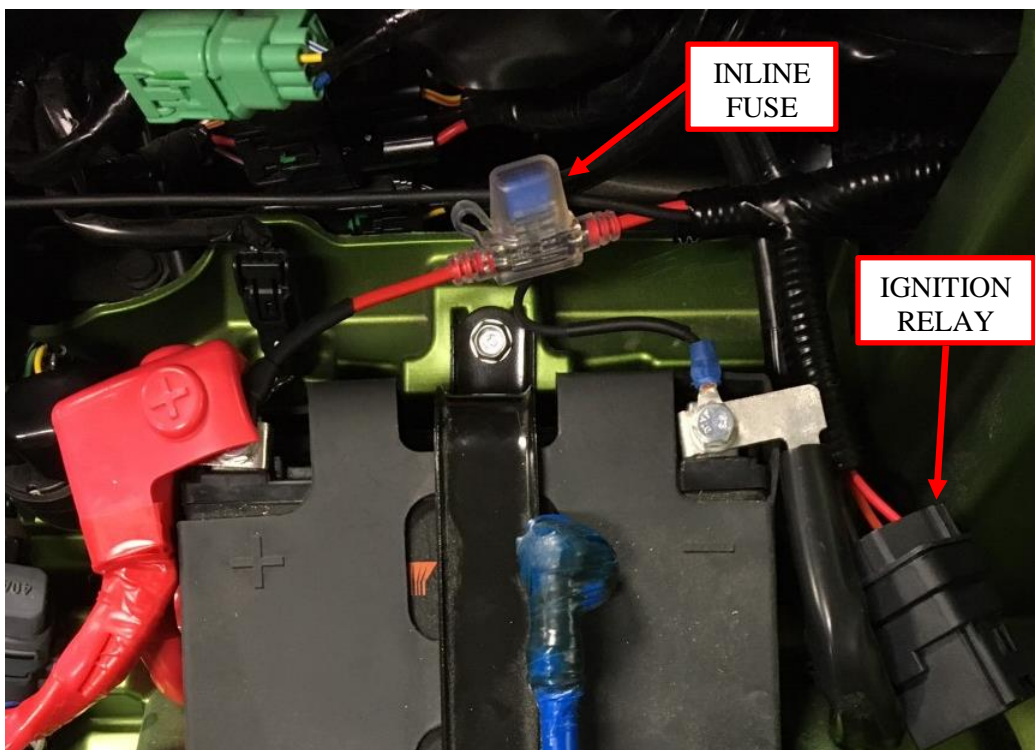

Figure 1: Fuse location.

- Fuse 1: 15 amp mini fuse for light / radio receiver power.

2.5 Warnings:

This off-road system adds up to 25 lbs. to your vehicle and is located up high on the roll cage. This increases the vehicle's center of gravity and changes the vehicle dynamics and handling characteristics. Use extra caution as you learn the driving characteristics of your vehicle with your new off-road sound system installed. High speed cornering, off camber or side hill, acceleration, and braking performance will be negatively impacted by the weight of the sound system.

Do not listen to your stereo at an uncomfortable volume for extended periods of time. Potential hearing loss may result.

SECTION 3 – Pre-Installation Inspection

Included in your off-road sound system are the following components:

- Pre-assembled *Audio Mini* off-road sound system (All speakers and electronics come preinstalled with interior wire harness.)
- Chassis wire harness
- Mounting brackets
- Hardware bag
- Zip ties

If any of the parts are missing, damaged, or you have any questions concerning them, please call Hoppe at (262)-552-2770 Mon-Thur. 8am-5pm CST.

In addition to accounting for all of the parts that you should receive with the top, you should inspect the vehicle in the following ways.

- Ensure that the vehicle is equipped with the factory roll cage, and the roll cage has not been bent out of shape in a roll over.
- Make sure the vehicle does not have any aftermarket accessories that are incompatible with the top.
- Make sure the battery is in good condition and holds a charge.
- Make sure the charging system is in good condition.

SECTION 4 – Installation

1. Place the provided loop clamps in the approximate mounting location on the roll bars. The *Audio Mini* brackets will rest on the loop clamps and be tightened in the following steps. See Figure 2.

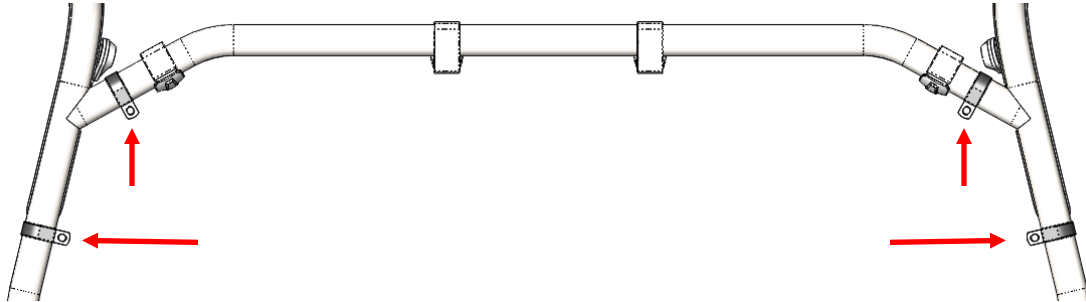

Figure 2: Approximate locations of the loop clamps.

2. Use the supplied $3/8''-16 \times 1''$ bolts, washers, and nylock nuts to secure the loop clamps to the mounting brackets. Loosely tighten the bolts to still allow for adjustment of the *Audio Mini* placement. See Figure 3. **Note: Driver side bracket shown. (Passenger side similar)**

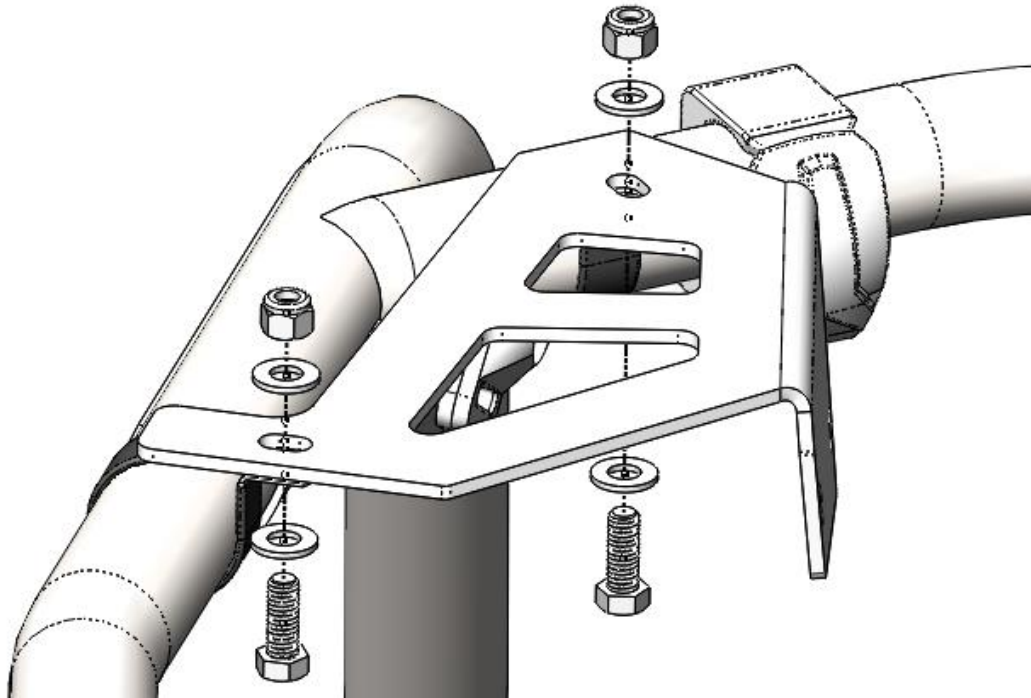

Figure 3: Hardware for mounting the loop clamps to the brackets.

3. Using an assistant, hang the *Audio Mini* off-road sound system on the brackets using the supplied $1/4''-20$ bolts and washers (loosely tightened). **Note: The sound system weighs up to 25 lbs. Since you will have to lift and bolt each end, it is helpful to have an assistant for this step.** See Figure 4 and Figure 5.

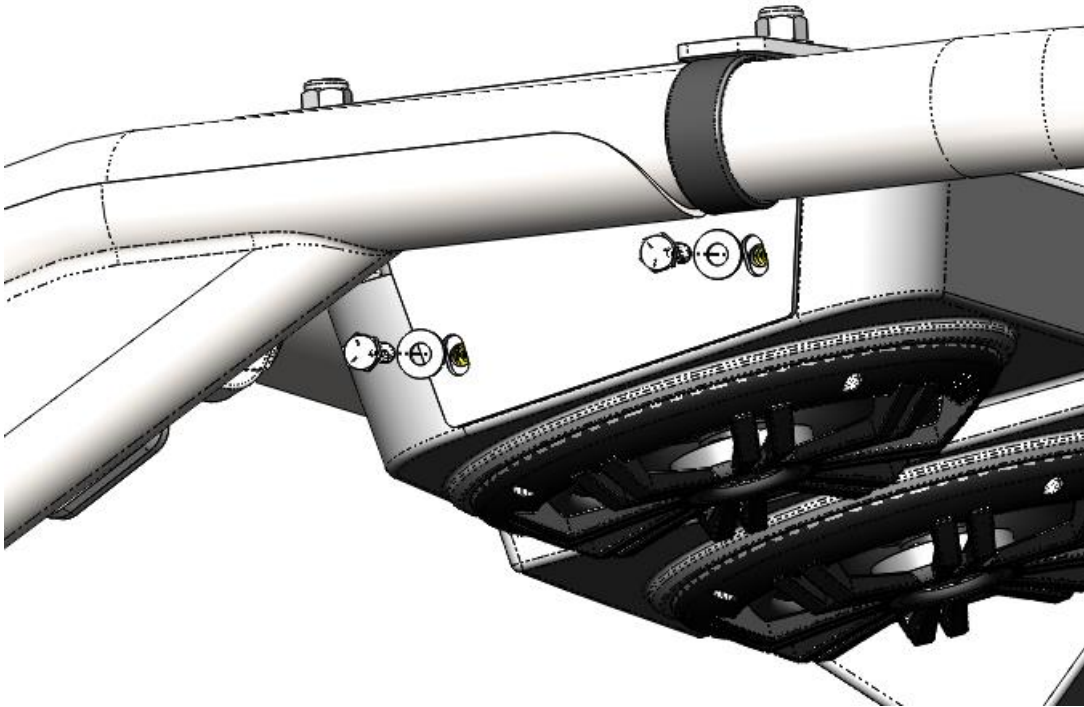

Figure 4: Install the 1/4\"-20 bolts and washers to mount the Audio Mini to the brackets.

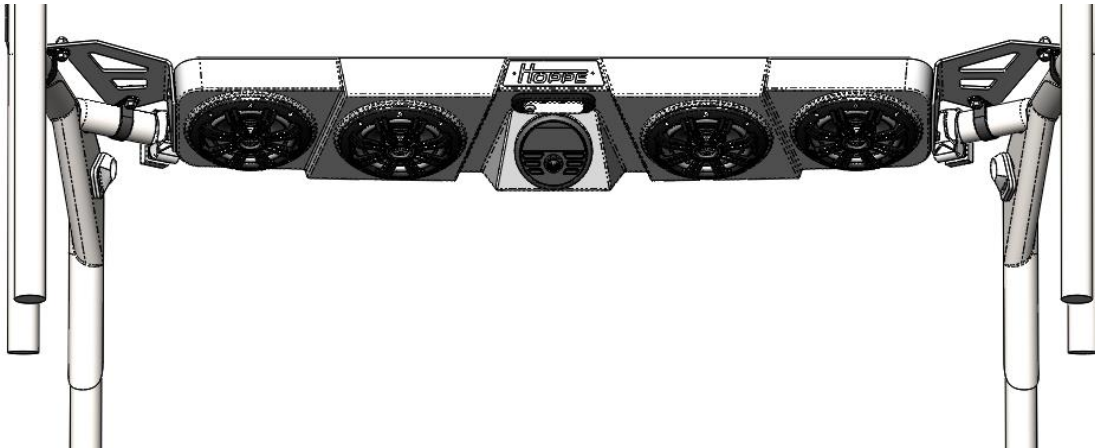

Figure 5: Loosely install the sound system on the mounting brackets.

4. Tighten the 4 loop clamp bolts so that the *Audio Mini* is equally spaced from the front roll bar. See Figure 6.

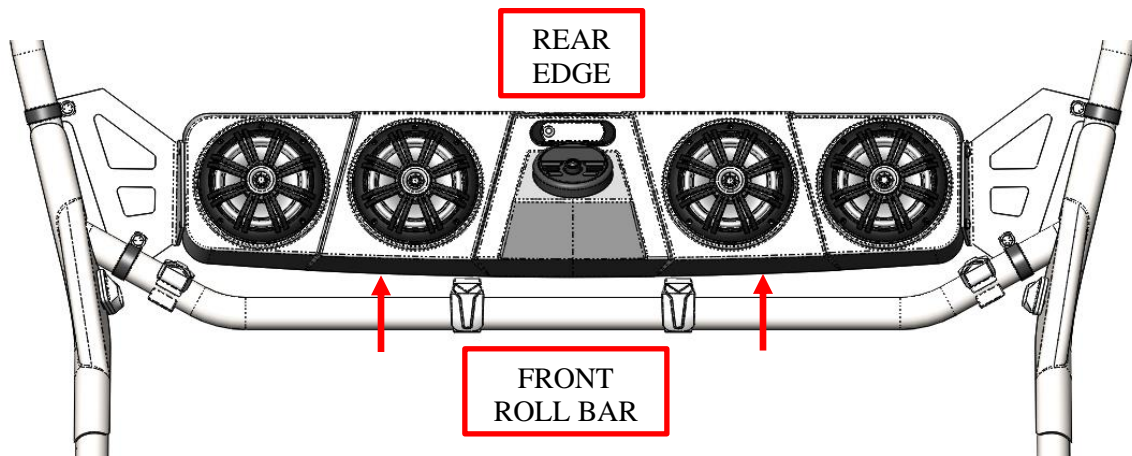

Figure 6: Audio Mini equally spaced from front roll bar.

5. Tighten the 4 mounting bracket bolts after achieving the desired viewing position. Slots in the brackets allow up-down movement. See Figure 7.

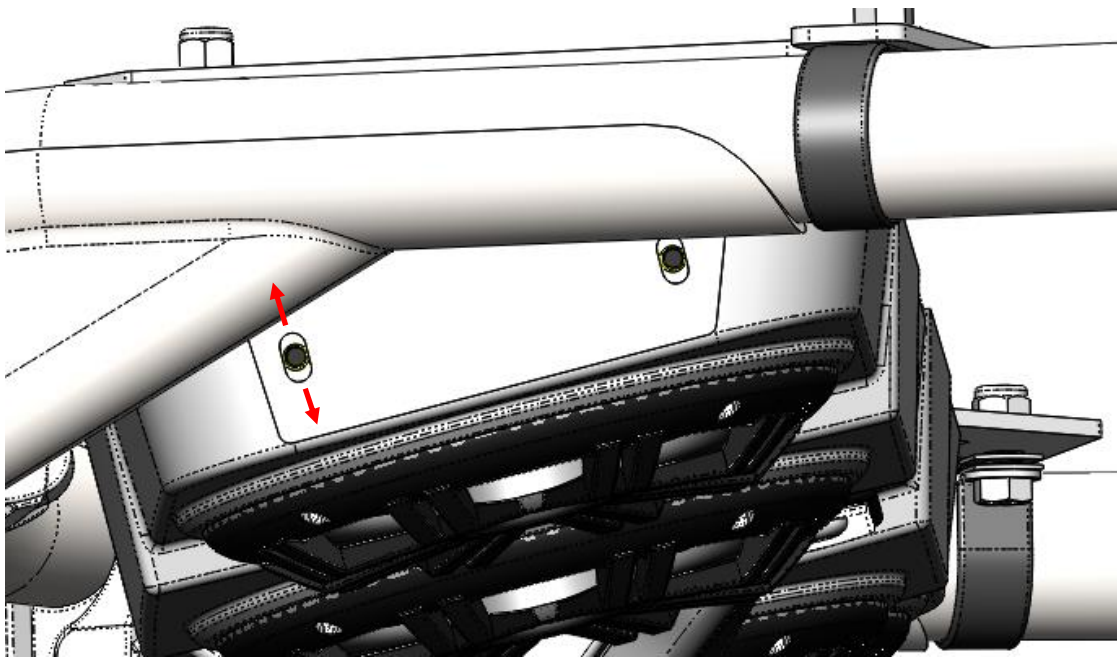

Figure 7: Up-down positioning of the Audio Mini.

6. Plug the chassis harness into the mating connector on top of the *Audio Mini*. Route the chassis harness over the front roll bar as shown in Figure 8.



Figure 8: Chassis harness connected and routed over front roll bar.

7. Route the chassis harness, using the provided zip ties, down the driver's front pillar. Zip ties are at the indicated locations. See Figure 9.



Figure 9: Route the chassis harness down the driver's front pillar.

8. Remove the radiator hood access panel from the front of the vehicle by lifting and rotating the $\frac{1}{4}$ turn clips, lifting the hood, and sliding it towards the front of the vehicle. See Figure 10.

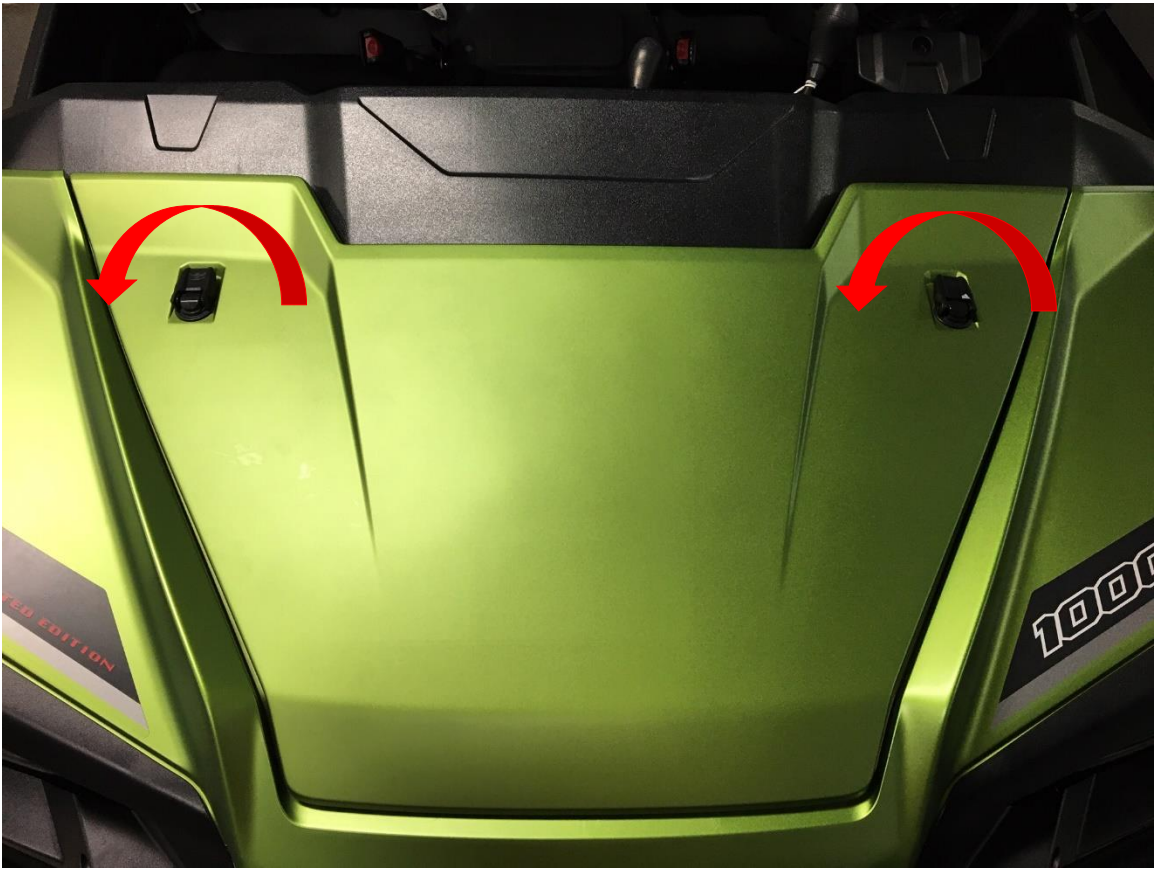

Figure 10: Remove the radiator hood access panel.

9. Remove the right Torx screw and the 3 plastic rivets to route the wiring under the plastic panel. The plastic rivets are released by first prying the center head up, then pulling the entire rivet out. See Figure 11.

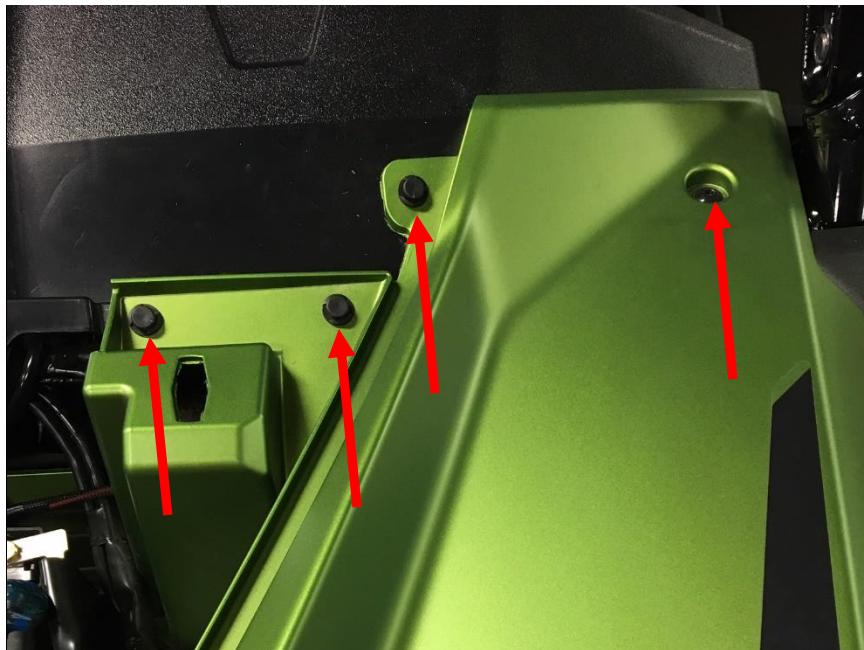

Figure 11: Remove the Torx screw and plastic rivets to run the chassis harness under the panel.

10. Connect the chassis harness battery cables to the battery. Remove the battery bolts from each terminal as you connect the cables, and replace the bolts with the provided M6 x 1.0 x 14 mm battery bolts to clamp the cables on top of the existing cables. Connect the red harness wire to the terminal with the existing red battery cable (+ 12V). Connect the black harness wire to the terminal with the existing black battery cable (- 12V). See Figure 12.

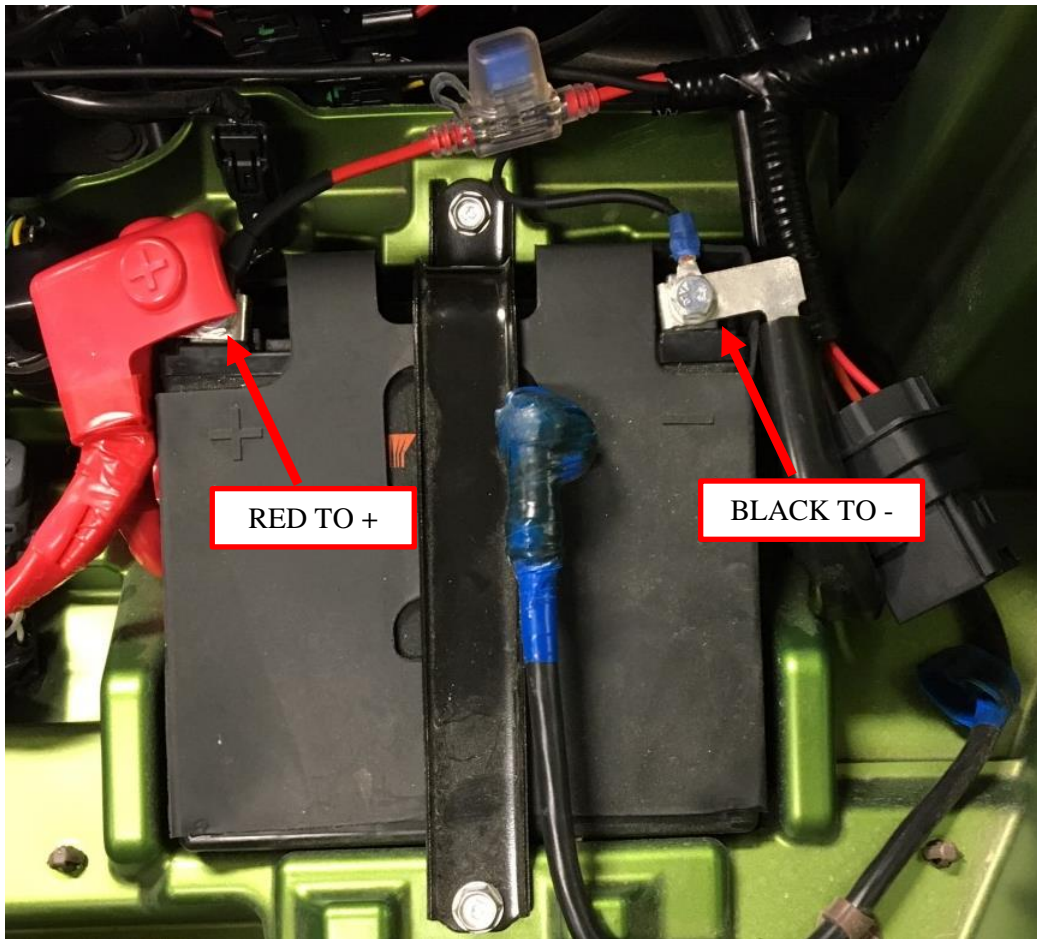

Figure 12: Battery cable connections.

11. Run the orange ignition wire, with the two attached connectors, through the hole in the rubber protector (with the factory wire harness). The connectors are accessible under the rubber protector by lifting the left rear corner of the rubber protector. See Figure 13 and Figure 14.

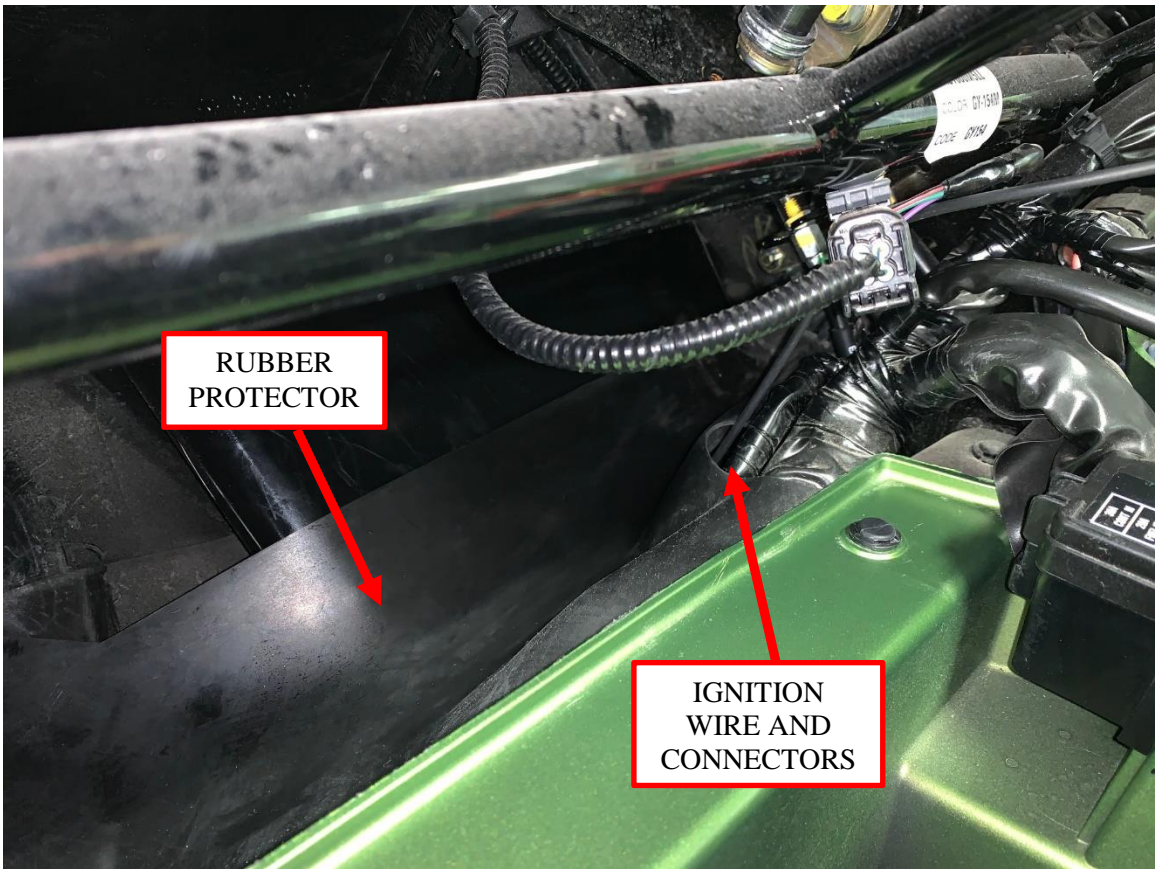

Figure 13: Ignition wire and connector routing.

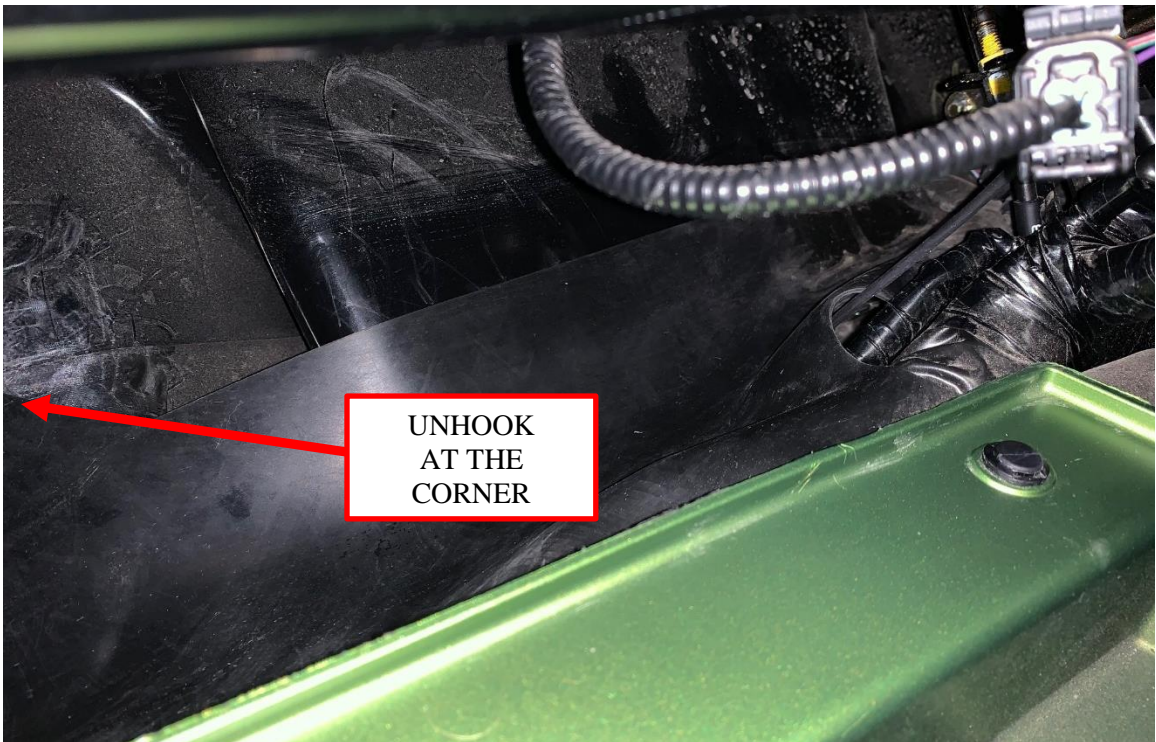

Figure 14: Rubber protector access location.

12. The female connector will replace the OEM connector attached to the back of the accessory cigarette lighter as shown in Figure 15. This connection point is accessible through the hood opening under the rubber protector (Figure 15 from wheel well shown for a better view). The male connector on the chassis harness can then be connected to the OEM female connector.

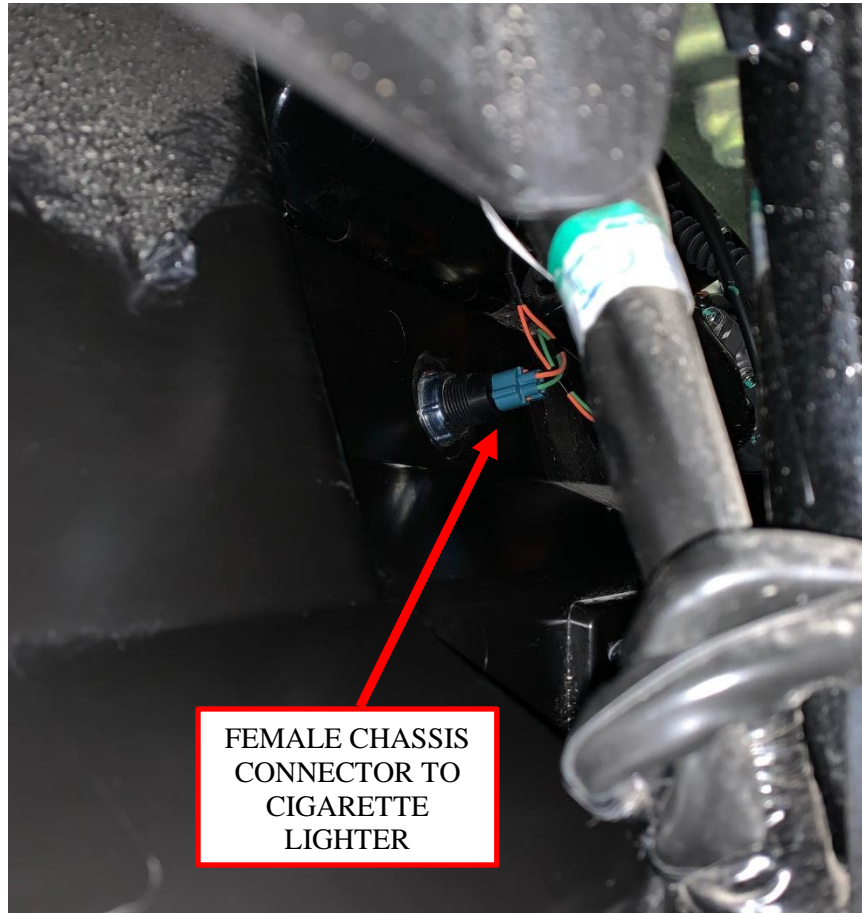

Figure 15: Connection location for chassis harness connectors.

13. Reinstall the Torx screw, plastic rivets, and hood.
14. You are now ready to enjoy the music and lighting provided by your *Audio Mini* off-road sound system. Basic operation works as follows:
- Turn the vehicle ignition switch on to power up the stereo system. (You must press the power button for first time connections or if the power was previously turned off manually.)
 - Press the source button on the stereo receiver to select the input source from AM/FM radio or Bluetooth.
 - Press and hold the menu button to access the Device Settings menu.
 - Use the Volume knob to change the values for each setting, and press it to confirm the setting.
 - Press and hold the Volume knob to access the Audio Settings menu.

- Use the Volume knob to change the values for each setting, and press it to confirm the setting.
- a. The dome light can be used with or without the vehicle's ignition switch on. Press the on/off switch to activate the light. **Warning: Extended use of the dome light or stereo without the vehicle's charging system functioning will deplete the battery and the engine may not start.**

To learn about the more advanced features and operation of your stereo, visit the Kicker website links found in SECTION 2 – About your Audio Mini sound system of this document.

Thank you for choosing the Hoppe *Audio Mini* off-road sound system for you Honda Pioneer UTV. We hope you enjoy your new sound system and lighting. We invite you, in your travels, to stop by our manufacturing plant in Troup, Texas, for a factory tour and to meet the people who designed and manufactured your *Audio Mini* off-road sound system. This will also give you an opportunity to check out our sister companies



and our extensive line of trike conversions, automotive, motorcycle, and power sports accessories.

We believe you will be impressed by what you witness and the people you will meet.