

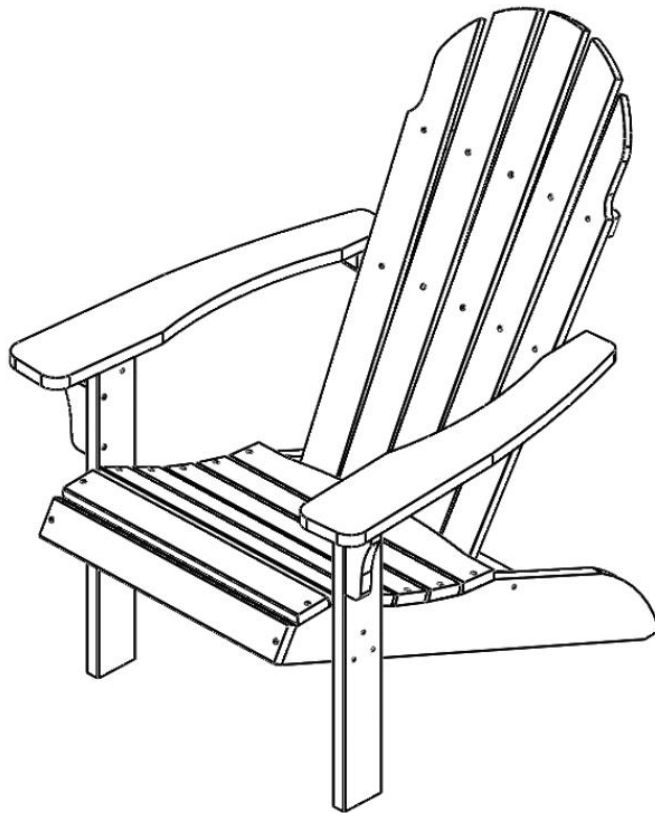

POLYTEAK®
OWNER'S MANUAL

ITEM NAME : Traditional Elements Adirondack Chair
MODEL : ELEM-TRN



**For assistance with assembly, please contact customer service
1-949-316-0010 or Email: Support@polyteakoutdoor.com**

PRE-ASSEMBLY PREPARATION:



THIS PACKAGE MAY CONTAIN SMALL ITEMS WHICH SHOULD BE KEPT AWAY FROM CHILDREN

- Please check that all parts and hardware are included before beginning assembly.
- Save all packing materials until assembly is completed to avoid accidentally discarding small parts
- Read through the preparation and assembly instructions in full before beginning assembly.
- Please use CAUTION AND CARE WHEN LIFTING the product to avoid personal injury and (or) damage to the product.
- For ease of assembly, two adults are recommended; Assembly time: Approximately 30 minutes.

PANEL AND FITTINGS IDENTIFICATION:

A. Right Arm 1Pc



B. Left Arm 1Pc

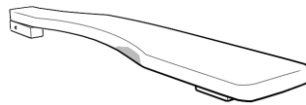

C. Pack Panel 1Pc

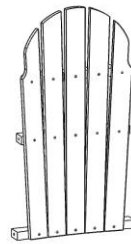

D. Seat 1Pc

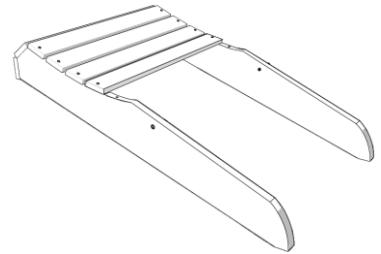

E. Front Legs 2Pcs

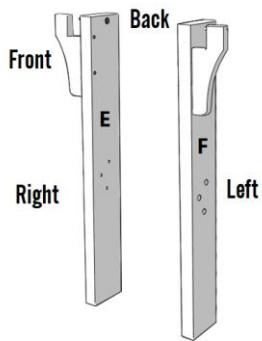

I. Last Slate on Seat

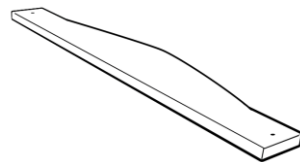

S. Allen Wrench 1Pc



T. Sanding Sponge for Cleaning



HARDWARE LIST:

G: Long Bolt. 2-3/8"
2Pcs

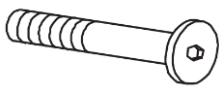

H: Short Bolt. 1-3/4" 10Pcs

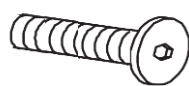

J. Wood Screw 2Pcs

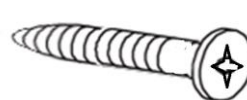

Philip Head Screwdriver



Missing Parts? Lost Hardware? Need Assistance?



WE CAN HELP!

For fastest service, contact us directly!

Phone:
(949) 316-0010

Email:
support@polyteakoutdoor.com



STRUCTURE DIAGRAM :

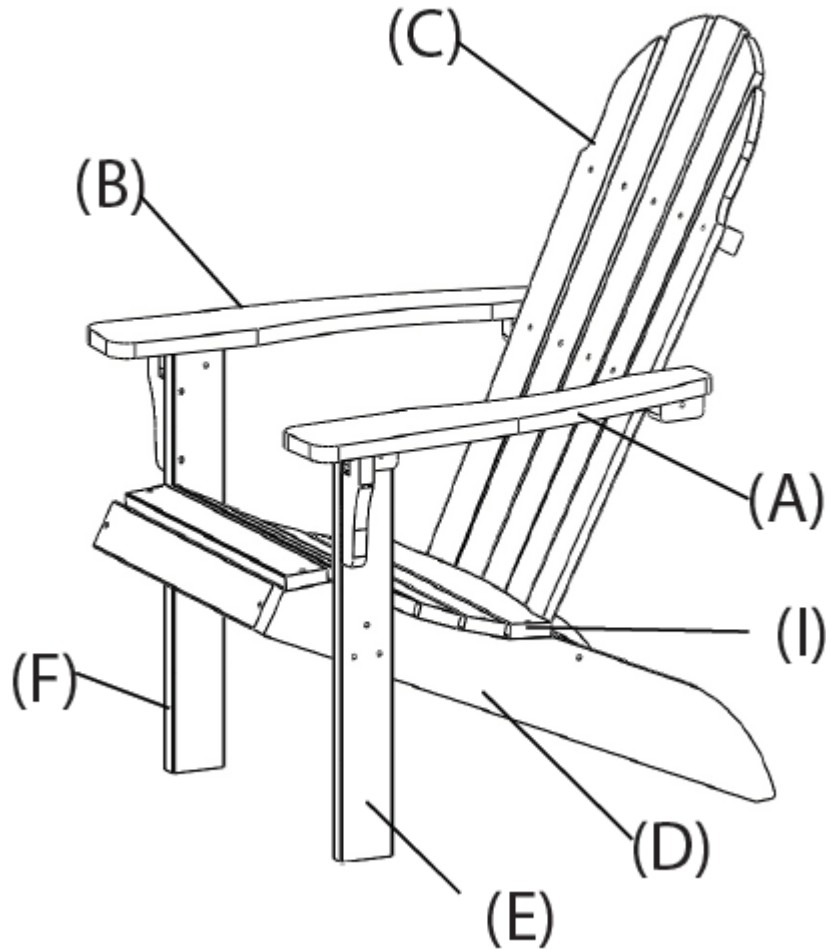

STEP-BY-STEP ASSEMBLY:

STEP 1: Attached the Curve Slate (Part I) to the Seat

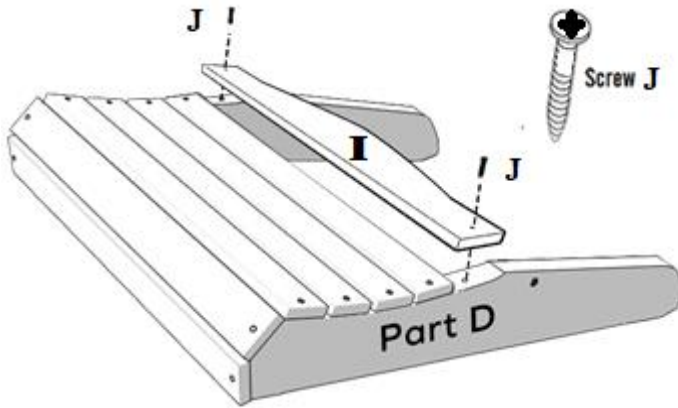

STEP 2: Attach 2 Front Legs to the Seat
Important note: Do Not Over Tighten Bolts

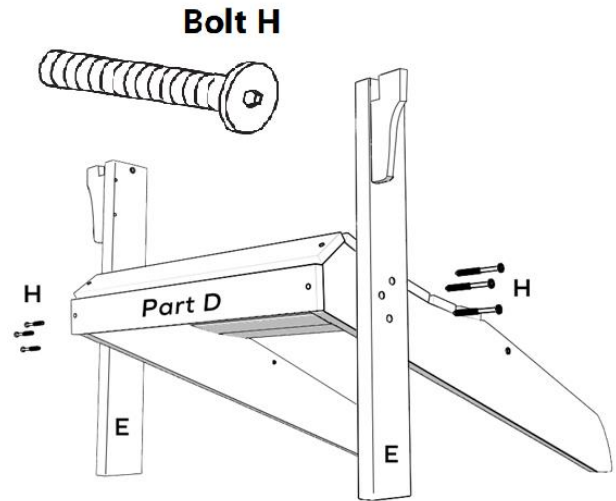

STEP 3: Attached 2 Arms to the Front Legs

Important note: Do Not Over Tighten Bolts

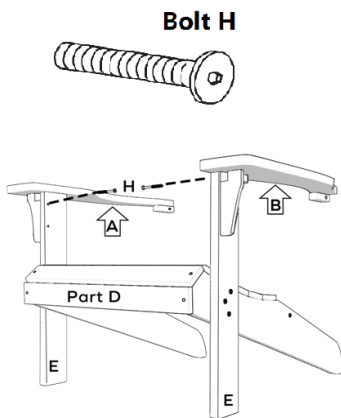

STEP 4: Attach Back Panel to the Seat

Important note: Do Not Over Tighten Bolts

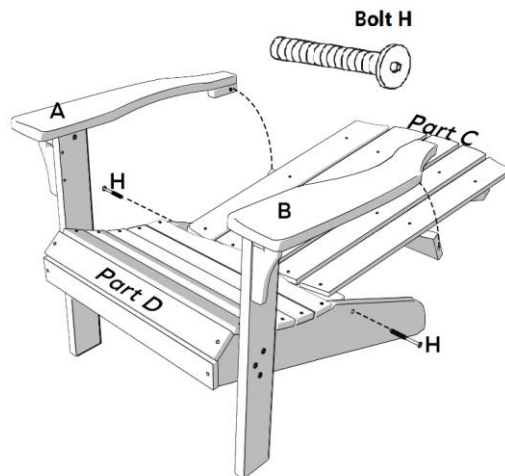

STEP 5: Attach Back Panel to the Arms

Important note: Do Not Over Tighten Bolts

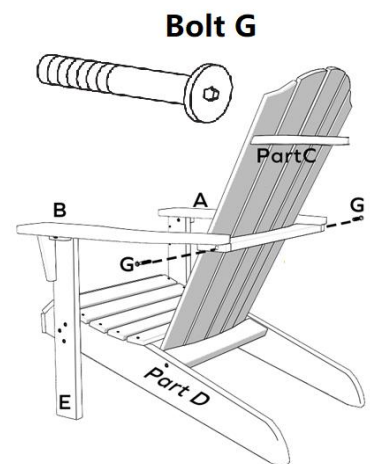



www.polyteakoutdoor.com
info@polyteakoutdoor.com
(949) 316-0010

CARE & MAINTENANCE

This furniture product is made of 100% PolyTEAK® lumber, an all-weather material that is naturally resistant to water. With the combination of marine-grade hardware and all-weather design, you can have complete confidence in leaving your newly acquired PolyTEAK furniture outside season after season.

Routine cleaning of the furniture can be completed with only warm water and soap, while bleach may be mixed with the water (25% Bleach, 75% Water) for extra cleaning power. A stiff bristle brush can help to remove any particles from between the simulated wood grain.

Comments or Questions?

Email: info@polyteakoutdoor.com

Phone: (949) 316-0010

Monday - Friday, 10AM - 5PM PST

WARRANTY REGISTRATION

Registering your product with PolyTEAK ensures that it will be covered by our manufacturer warranty.

To register your product, please visit:
www.polyteakoutdoor.com/pages/product-registration

**Think Green.
Think PolyTEAK®.**



Our PolyTEAK® products are all built tree-free and are 100% recyclable.







www.polyteakoutdoor.com
info@polyteakoutdoor.com
(949) 316-0010

TEA TIME

Dear friends,

Now, the setup is done, PolyTEAK hassle-free outdoor furniture has come! Sit back, enjoy our special recipe of ice-tea. Don't worry and have fun!

Refreshing your outdoor time	
Cold brew iced tea with Fresh Fruit recipe	
	4 bags of black tea
	6-8 sliced strawberries
	1/2 thinly sliced lemon
	Small handful basil leaves
	Put all in a pitcher then in refrigerator for 8 + hours.

Share your outdoor good time pictures with us on social media using #polyteak
You can find more refresh Outdoor Recipe from this link: www.FreePolyTeak.com/Recipes

Sincerely,
Tea Specialist from PolyTEAK Outdoor.