

Height Adjustable Electric Glass Desk

Assembly & Operating Guide

ITM./ART.AIT0029B/W

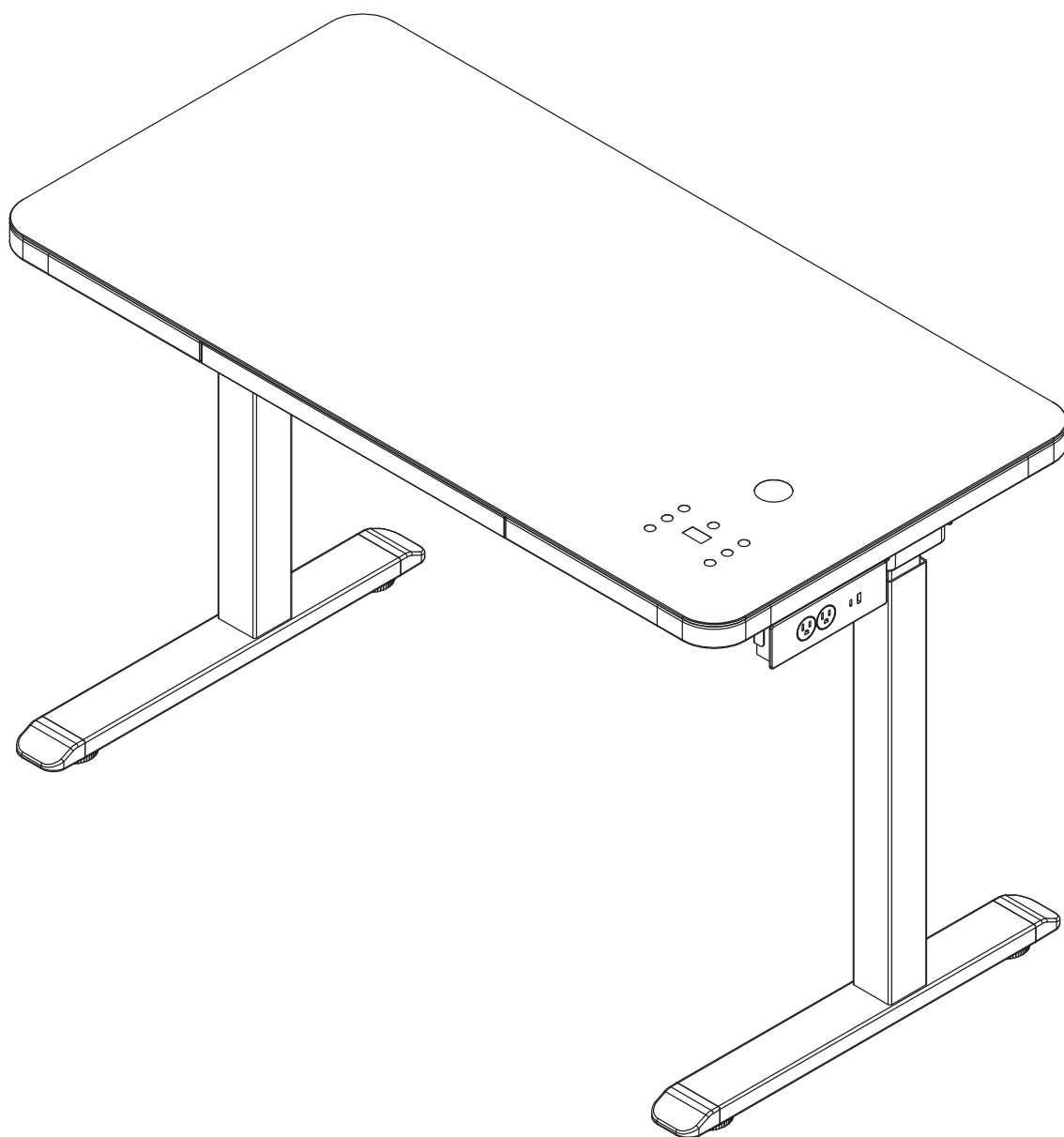

IMPORTANT: Retain this manual for future reference. Read Carefully.



Caution

- When using electrical appliances, basic precautions including the following, should always be taken to reduce the risk of fire, electrical shock, and injury to persons.

Warning:

- Make sure the unit is turned off and unplugged before cleaning.
- Do not connect the power supply to a household power outlet with wet hands, as it may cause fire, electric shock or injury to the person.
- Do not operate this unit if the cord or plug is damaged, after a malfunction or if it has been dropped or damaged in any manner.
- For indoor use only.

PRODUCT SPECIFICATIONS

Input Voltage	100-240V
Output Voltage	29V DC 3A
Max Load	80kg/176lbs
Load Speed	32mm/s / 1.3in/s
Lift Range	27.9in to 45.6in

SPECIFICATIONS-Power Unit

Dimension	Product	186*62*31.7mm
Ports	AC Outlets	2xNEMA 5-15R
	USB Ports	1xUSB-A, 1xUSB-C
Cord	Length	59" (1.5m)
Electrical Rating	Rated Power	1140W
	Output Current	12A
	Input/Output Voltage	AC 110-125V
	USB Ports	Connected to one of the two ports USB-A: 5V/3A, 9V/2A, 12V/1.5A (18W max), QC 2.0/3.0 USB-C: 5V/3A, 9V/2A, 12V/1.5A (18W max), PD 3.0
Both ports connected USB-A and USB-C: 5V/3A (15W max)		

SPECIFICATIONS-Wireless Charger

Parameter	Input	9V2A
	Output	5W/7.5W/10W/15W
	Power Conversion	≥80% @10W
	Charging Distance	3-8mm
	Work Frequency	110-205kHz
	No-load Power Consumption	9VDC Input, the average power consumption≤0.1W
	Execution Standard	WPC 1.2.4
	Working Temperature	0°C to +40 °C
Certificate	Qi V1.2.4 FCC/IC	

SAFETY INFORMATION

- Please read and understand this entire manual before attempting to assemble, operate or install the product.
- Some steps are more easily handled with two adults.
- Before assembly and/or installation, carefully unwrap all parts.
- Locate and set aside the hardware kit before discarding packaging.
- Use care when assembling your new product. Take your time and follow assembly instructions closely.

TEAM HANDLE



Part list

A

[x1]

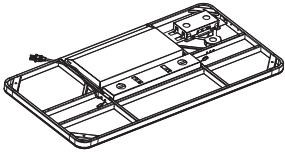

Worksurface

B

[x2]

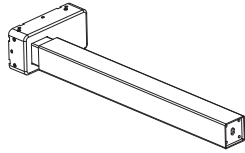

Legs

C

[x4]

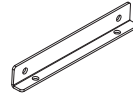

Brackets

D

[x2]

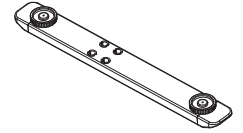

Feet

AA

[x8+1]



M6*8

BB

[x1]



4mm Allen Key

CC

[x8+1]



M6*16

DD

[x8+1]



M5*12

EE

[x1]

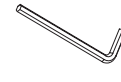

3mm Allen Key

FF

[x6]

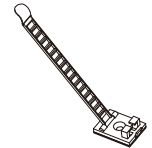

Adhesive Cable Tie

A

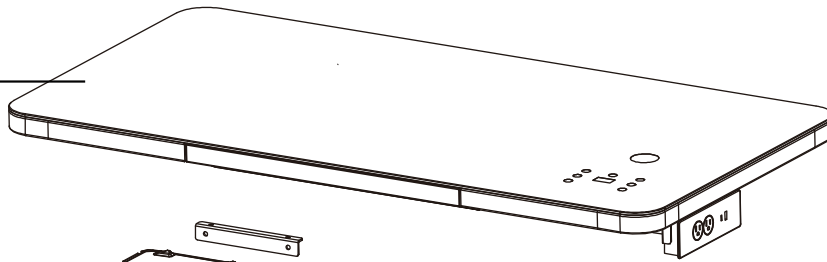

C

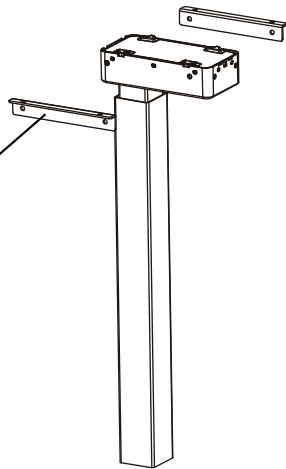

B

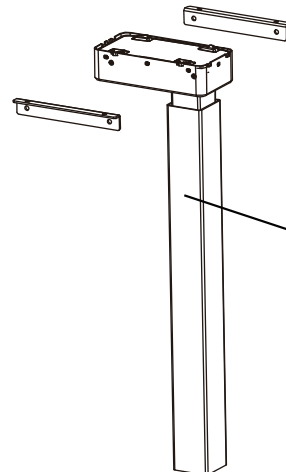

D

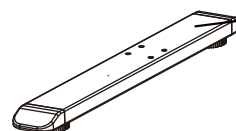

Step 1#:

- Place the worksurface facing down on a soft, clean surface.

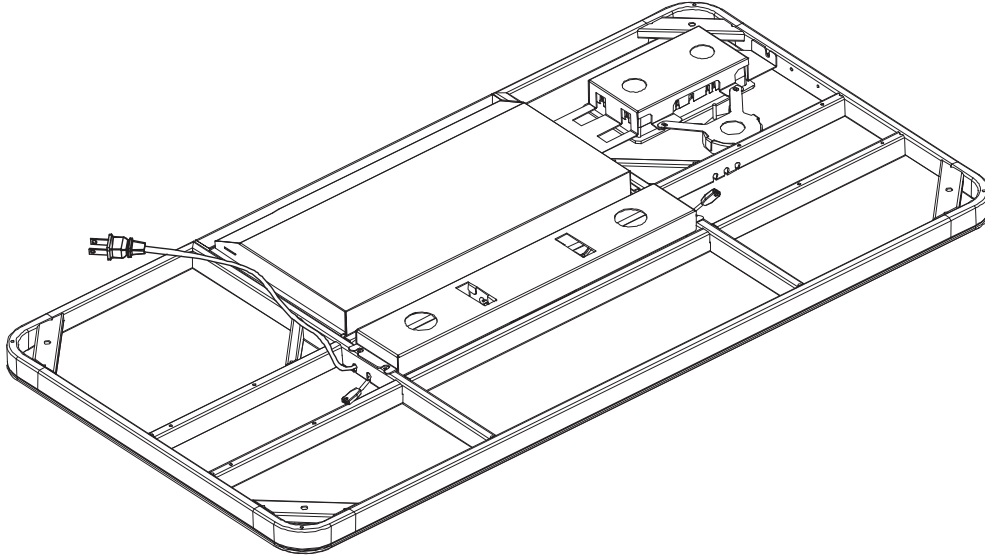

Step 2#:

- Attach each leg B to the two Brackets C with four AA M6x8 screws per leg, as shown direction of C upper screws with Allen Key BB.

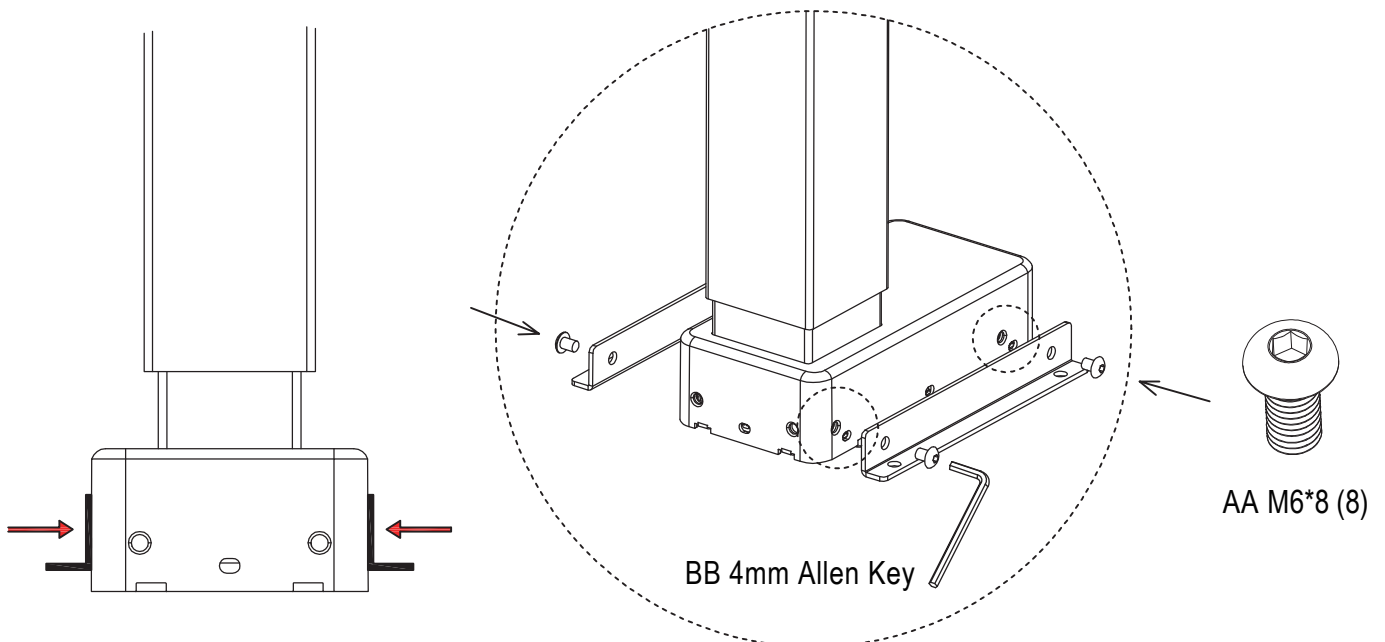

Step 3#:

- Attach the Legs B to worksurface A with four DD M5x12 screws per leg, as shown direction of C bottom screws with Allen Key EE.

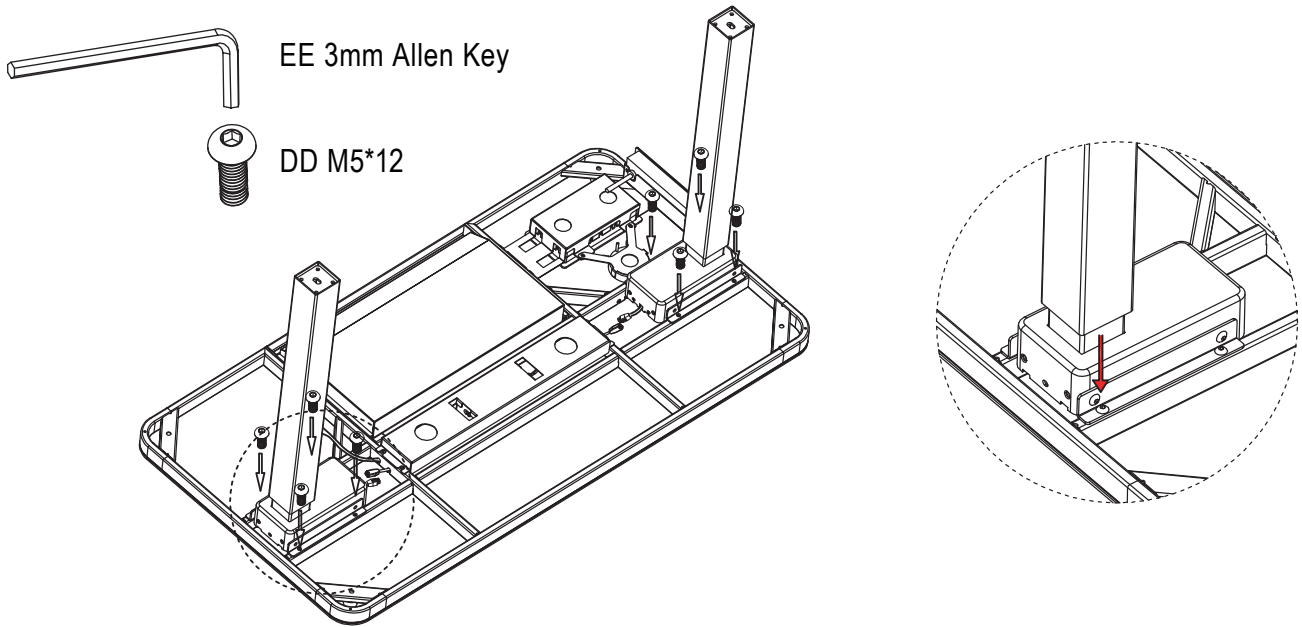

Step 4#:

- Attach a foot D to each leg B with four CC M6x16 screws per foot. As it is C feet shape, make sure longer side to the drawer director as arrow show below.

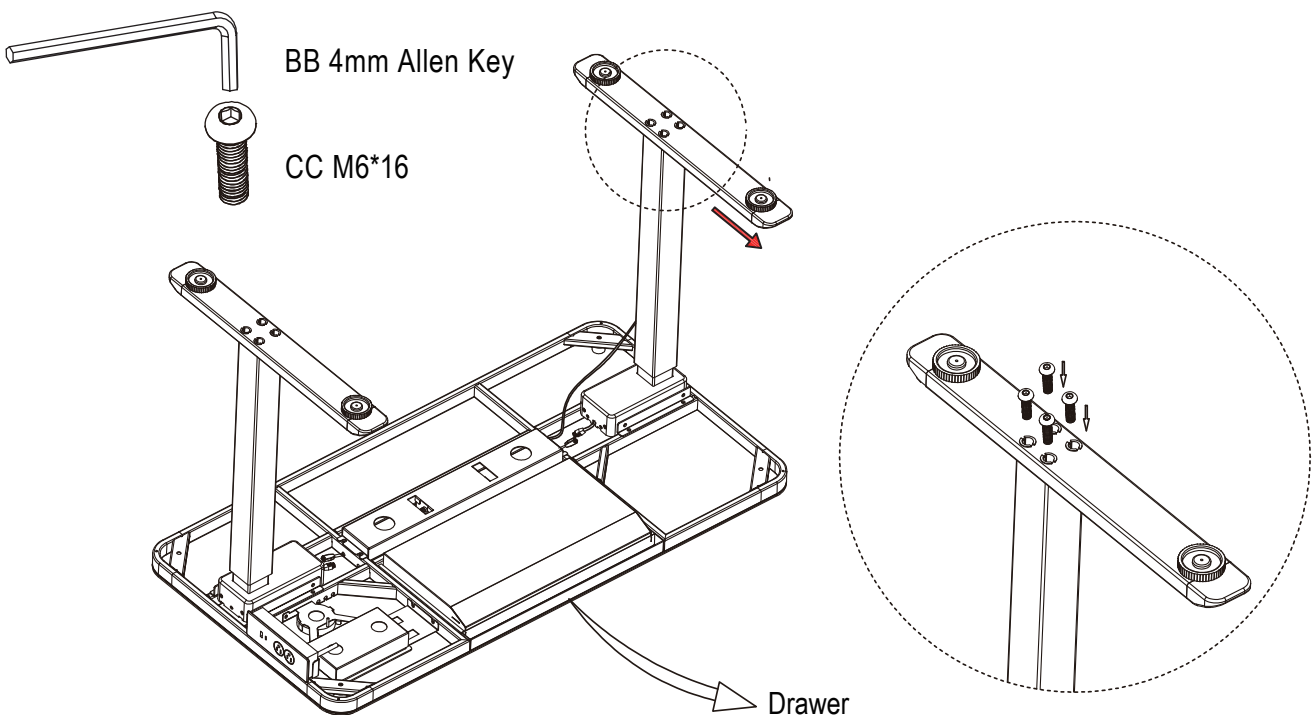

Step 5#:

- Connect the cables from each of the leg motors to their ports on the controller cables. If need, place the adhesive cable ties DD on the bottom of the worksurface to control the cables and power cord.

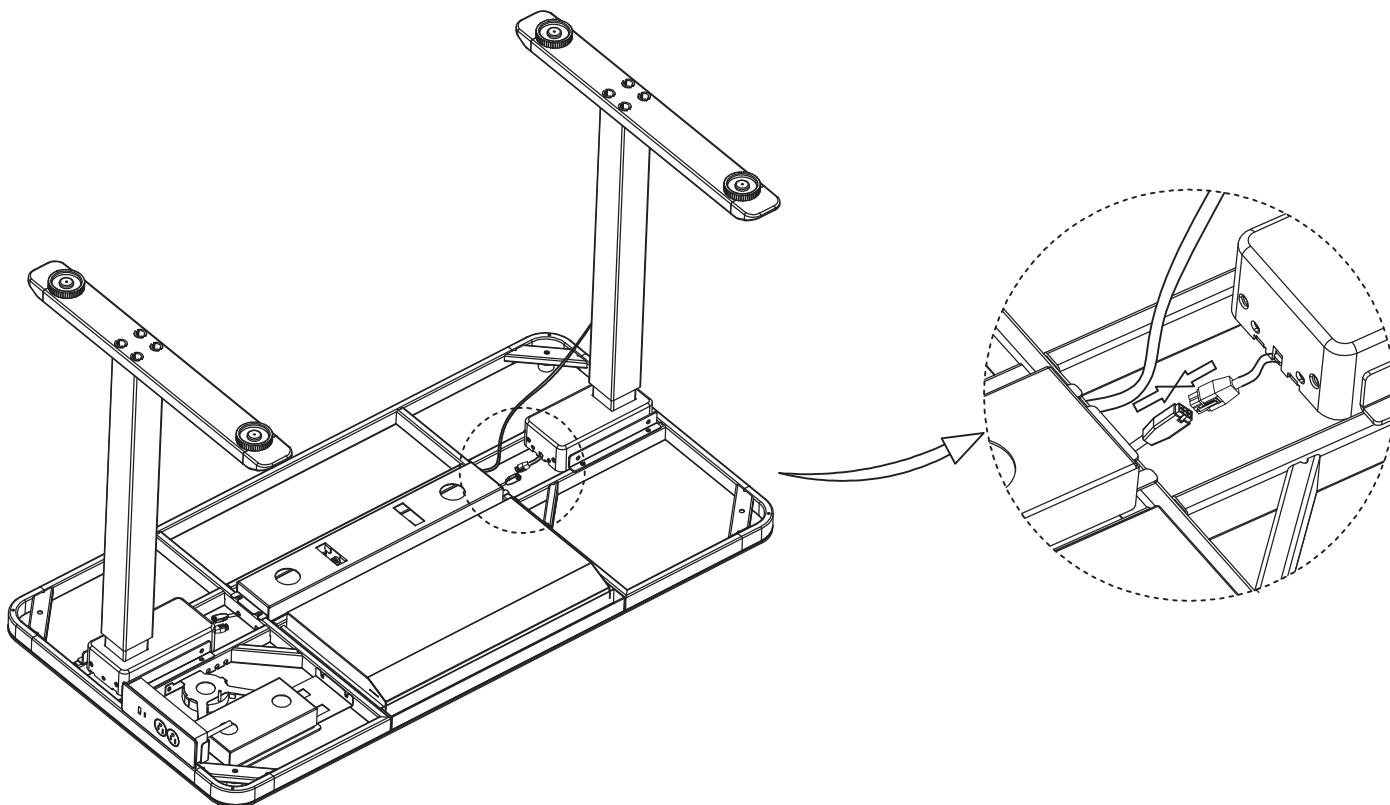

Step 6#:

- With the assistance of a helper, turn the table upright and place it in its final position.
 - **Important:** There must be one inch of clearance on all sides of the worksurface (and other moving parts) to ensure free, unobstructed movement.
- If necessary, adjust the leveling glides on the feet to level the worksurface.
- Plug the power cord into an AC outlet.

Operations:

Once your desk is fully assembled, you will then need to activate the motors using a quick sequence on the control panel, please refer to the following steps below to activate your desk.

- After each installation of the table, the table system needs to be reset to initialize the system:

Begin by pressing and holding "v" key on the control panel to minimum height "27.9", release "v" key, then hold down "v" key for 5 seconds until motor stops, note that the "v" key can not be released during this process. If you release the "v" key, the initialization process stops. If initialization is complete, you will hear a slight beep sound followed by brief flash "27.9" on the display. If the system is abnormal, "RST" indicates that the system needs to be initialized on the panel screen.

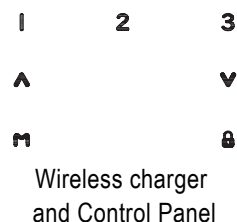

Display:

- **Button:**

Press this button to lock the touch-screen. This will prevent accidentally engaging the controls after the desired height has been set. Press the button again with 3 seconds to unlock the touch-screen.

- **Normal operation:**

The display will indicate the height of the desk (inches). After five seconds without input, the digital readout will automatically fade away.

Touch and hold the "v" button to lower the desk and release when it arrives at the desired height.

Touch and hold the "^" button to raise the desk and release when it arrives at the desired height.

- **Setting of Memory Height:**

First lift the desktop to the height you need to remember, then press the "M" button, and the display displays "S-", and "-" flicker, and then press the "1-3" button. You can complete the corresponding memory height settings. Memory height data is not reset with power on and power off.

- **Wireless charger:**

Please make sure the phone center in the printing circle center area, when the location is matched, the electrical charging will be effected in 3 seconds. The wireless charger will pause charging temporarily when the height of the desk is being adjusted and the motor is in use.