

HEAVY DUTY BUMPER INSTALLATION FBM04CHN

2007-10 CHEVROLET Silverado HD Pickup

5/19/17

Hardware Kit Includes:

- (1) 12 – Hex head bolts (1/2"-13 x 5") Grade 8
- (2) 14 – Lock washers (1/2")
- (3) 26 – Flat washers (1/2")
- (4) 14 – Hex head nuts (1/2"-13) Grade 8
- (5) 2 – Allen head bolt (7/16"-14 x 1")

Components List:

- 1 – Heavy Duty Bumper
- 2 – Mounting brackets (BP5277)
- 2 – Spacer sleeves (BP5376)
- 2 – T-bolts (PN412)

**Repeat For
Reverse Side**

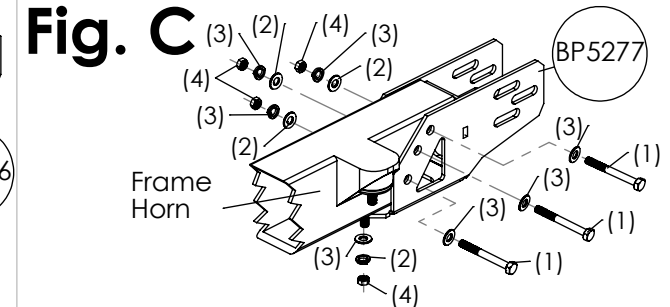
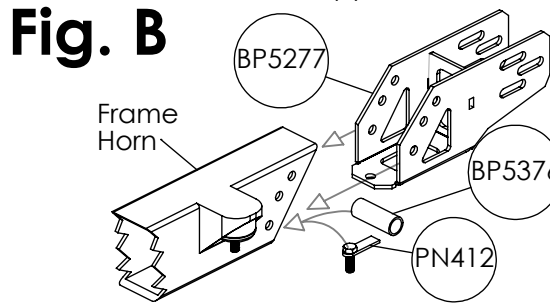
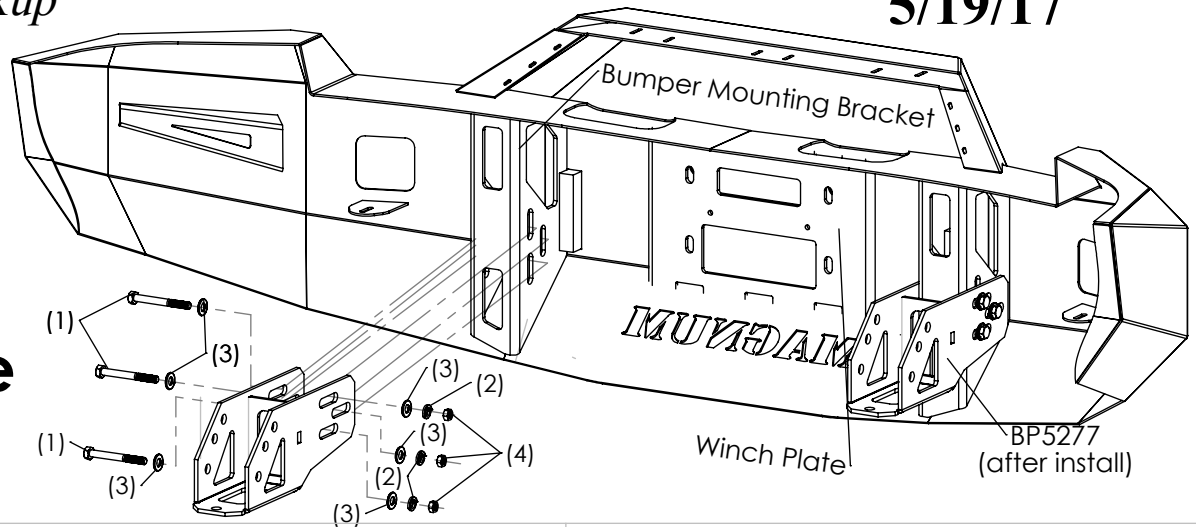

**LOOSE FIT ALL COMPONENTS.
DO NOT TIGHTEN UNTIL ALL
COMPONENTS ARE INSTALLED
AND ADJUSTED.**

**DISCLAIMER: USE ONLY COMPONENTS
AND HARDWARE SUPPLIED BY ICI.
NO SUBSTITUTIONS.**

Step by Step Installation Instructions

STEP 1: Read and understand instructions completely before beginning installation.

VEHICLE PREPERATION

STEP 2: Disconnect the factory fog lamp connectors (if applicable).

Remove factory bolts from outer bumper support tubes (two bolts per side). Remove the dart clips holding the rubber valance between the frame and the bumper.

STEP 3: Remove the factory nuts (2 per side) from the bolt strips holding the bumper brackets to the frame. **Note: Make sure to support bumper BEFORE removing bolt strips.** With the bumper supported remove the bolt strip holding the bumper to the frame. Pull outward at the fender wells and remove the bumper from the front of the truck. With the bumper removed from the truck, remove the factory tow hooks.

BUMPER INSTALLATION

STEP 4: Remove and layout all components from the box and lay out on blanket (to prevent damage to the powder coating).

STEP 5: If installing winch and roller fairlead (not provided) into bumper, do so at this time. Bottom bolts (not provided) go through fairlead, then into winch. Thread cap screws (5) through hole in front bumper and into winch body. Note: Winch should be bolted to winch plate with two additional fasteners (optional).

STEP 6: Slide mounting bracket #BP5277 onto inner bracket of bumper as shown (Fig. A). Loosely bolt mounting bracket to inner bumper bracket using hex head bolts (1), lock (2), and flat (3) washers and hex head nuts (4) as shown (Fig. A). Repeat for other side.

STEP 7: Carefully align mounting brackets with the frame (It may be helpful to support bumper with floor jacks during install). Insert spacer sleeve #BP5376 into frame and line it up with bottom factory hole as shown (Fig. B). Slide Mounting brackets and bumper assembly onto the frame as shown (Fig. B). Secure assembly with hex head bolt (1), lock (2), and flat (3) washers, and hex head nut (4) as shown (Fig. C). **Note: Be sure to slide bottom bolt through spacer sleeve.** Insert T-bolt #PN412 into frame in factory hole facing downward through frame and bracket #BP5277 as shown (Fig. B). Secure T-bolt with hex head nuts (4), lock (2), and flat (3) washers as shown (Fig. C).

STEP 8: Check fit and alignment.

- Adjust the bumper and tighten all fasteners; beginning with frame mounts then tighten all mount to bumper fasteners.
- Trim inner-fender liners to match bumper if desired.

ICI provides the best in off-road bumpers equipment.