

OVAL BAR INSTALLATION

2010-17 Dodge Ram Mega Cab 2500/3500

2009-17 Dodge Ram Quad/Crew Cab 1500

FV3005

5/18/17

Hardware Kit Includes:

- (1) 6 – Hex head nuts (12mm-1.75)
- (2) 6 – Lock washers (12mm)
- (3) 6 – Flat washers (12mm)
- (4) 18 – Hex head bolts (10mm – 1.5 x 35mm)
- (5) 18 – Lock washers (10mm)
- (6) 18 – Flat washers (10mm)
- (7) 6 – Plastic push nuts (12mm)
- (8) 6 – Rubber gasket

Components List:

- 2 – Stainless steel oval step bars
- 4 – Front and Middle Mounting Brackets (PN2278-A)
- 2 – Rear Mounting Bracket (PN2278-B)
- 6 – T-bolts (PN2276)

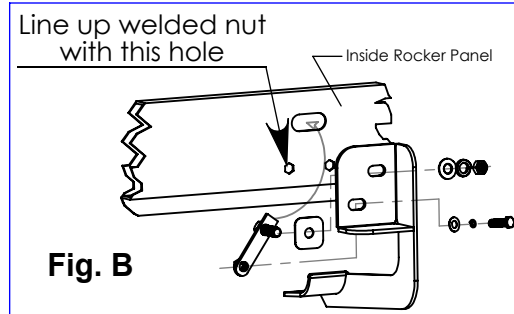

***Must remove all nutserts from inside rocker before installing brackets. Brackets must fit flush to inside rocker.**

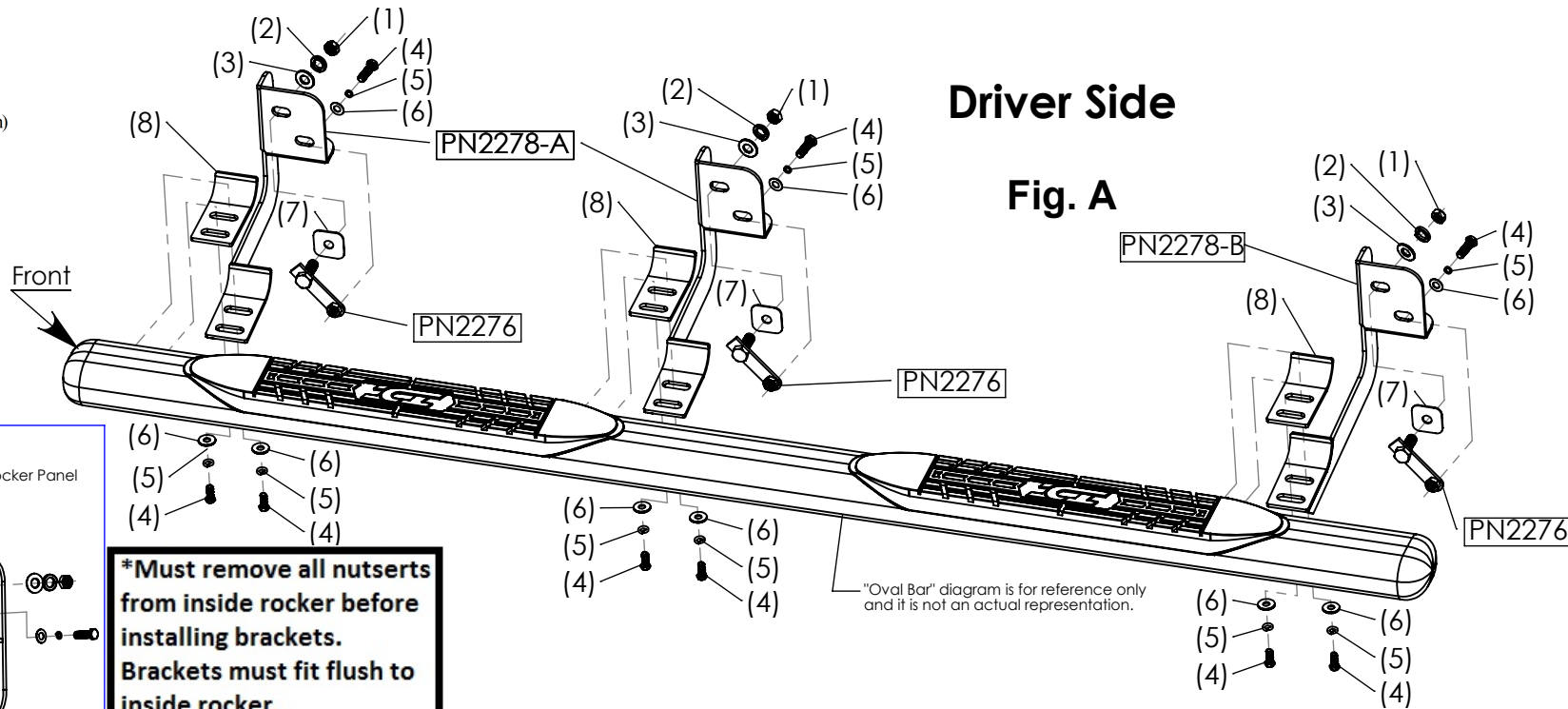

Step by Step Installation Instructions

- STEP 1:** Read and understand instructions completely before beginning installation.
- STEP 2:** Remove all old steps and hardware from truck.
- STEP 3:** Locate the drivers side brackets and identify the front and middle brackets from the rear. (The bracket faces that attach to the inside rocker panel point towards the rear) (The front and middle brackets have the oval bar cups welded on the same side as the bracket face (PN2278-A). The rear oval bar bracket cup (PN2278-B) is welded on the opposite side of the bracket face.) (See Fig. A)
- STEP 4:** Insert the supplied T-bolts (PN2276) into the holes on the inside of the rocker panel and secure using the push nut (7). The welded nut end of the T-bolt (PN2276) will line up with the bottom hole towards the rear. See Fig B. (Note: The holes you will be using may be covered up by factory tape.)
- STEP 5:** Place the front bracket in position (PN2278-A) with the T-bolts (PN2276) going through the top holes of the brackets and loosely thread the supplied 12mm flat washer (3), lock washer (2), hex nuts (1).
- STEP 6:** Now rotate the T-bolt (PN2276) until the welded nut lines up with the hole of the rocker panel and the bracket. Then thread the supplied 10mm bolt (4), lock washer (5), and flat washer (6) into the welded nut. Hand Tighten Only (Repeat steps 5 and 6 for the remaining brackets.)
- STEP 7: Position STEP BAR.**
- Mount step bar to mounting brackets (PN2278-A and PN2278-B) using 10mm hex head bolt (4), lock (5), flat (6) washers and rubber gasket (8) as shown. Hand tighten (do not use impact tools) into nutsert on the bottom of the step bar.
 - Adjust position of step bar and tighten all bolts. **Do not use impact tools.** Repeat for other side

LOOSE FIT ALL COMPONENTS. DO NOT TIGHTEN UNTIL ALL COMPONENTS ARE INSTALLED AND ADJUSTED.

DISCLAIMER: USE ONLY COMPONENTS AND HARDWARE SUPPLIED BY ICI. NO SUBSTITUTIONS.